



KENAI PENINSULA BOROUGH
QUARTERLY REPORT
OF KEY ECONOMIC INDICATORS

For Fiscal Quarter Ending June, 2006
Published September 2006

John J. Williams
Borough Mayor

Compiled and Produced by
Jeanne Camp, Economic Analyst
144 North Binkley Street
Soldotna, Alaska 99669
Phone – 907-714-2336

See this document on the web – <http://www.borough.kenai.ak.us>
Using the 'Economic Development' link

Index

	Page #
Introduction -----	2
Executive Summary-----	5
Kenai Peninsula Borough	
Sales - KPB Finance Department-----	13
Construction – City administrations throughout KPB -----	31
Employment St of AK, Dept of Labor -----	47
Population – U.S. Census Bureau -----	52
Homer	
Sales - KPB Finance Department-----	57
Construction – City of Homer -----	65
Kenai	
Sales - KPB Finance Department-----	71
Construction – City of Kenai-----	79
Seldovia	
Sales - KPB Finance Department-----	85
Construction – City of Seldovia -----	93
Seward	
Sales - KPB Finance Department-----	97
Construction – City of Seward-----	105
Soldotna	
Sales - KPB Finance Department-----	111
Construction – City of Soldotna -----	119
Other	
Sales – KPB Finance Department -----	125
Directory of Local Officials-- -----	133
Data Sources are listed for each subsection.	

Introduction

Kenai Peninsula Borough (KPB) staff develops quarterly reports containing economic data from throughout the area for use by businesses, agencies, and other entities to make planning and management decisions.

The publication is divided into eight sections: Kenai Peninsula Borough, Homer, Kenai, Seldovia, Seward, Soldotna, Other KPB, and a Local Officials Directory.

To provide unity within the document, certain conventions are applied:

- In the real estate section, the following abbreviations may apply:
 - RN - Residential New
 - RA - Residential Alteration/Addition
 - CN - Commercial New
 - CA - Commercial Alteration/Addition

- In Sales and Employment sections, the following abbreviations may apply:

AFF	Ag, Forestry, Fishing	Agriculture, Forestry and Fisheries (Includes Fish Buyers)
Min	Mining	Mining (Includes Oil & Gas Extraction and Production)
Const	Construction	Construction
Manu	Manufacturing	Manufacturing (Includes Oil & Gas Manufacturing and Fish Processing)
TCPU	Trans, Comm, Pub Util	Transportation, Communications, and Public Utilities
Whole	Wholesale	Wholesale Trade
Retail	Retail Trade	Retail Trade
FIRE	Finance, Ins, Real Estate	Finance, Insurance and Real Estate
Service	Services	Services
Govt	Government	Public Administration, Education and Service

- Information sources for each section are listed in the index.
- General information applicable to all sections is provided in the KPB section.
- Percentages of parts may not total 100%, due to rounding.

Information presented will assist in decision-making by providing economic and demographic information in graphic, table and text form. Local and state government officials; local, state and federal agencies; businesses within the Borough and elsewhere; and private citizens use data contained in the publication.

Data is received from various sources and is subject to change as updates, revisions and corrections are received. The KPB makes no claims to accuracy or completeness of information provided. Only summary information is published. For further detail, contact Jeanne Camp, Economic Analyst, KPB Community and Economic Development Division, 907-714-2336, or the data source listed in the index.

Quarterly reports are available electronically on the KPB website located at <http://www.borough.kenai.ak.us/CEDD/EconomicIndicators/publications.htm>.

To correct your mailing address or to be added to or deleted from the mailing list for this report, please email jcamp@borough.kenai.ak.us or call 907-714-2336. Be certain to identify yourself and the complete mailing address to be added or deleted. For additions, an email address is appreciated, which will be used for notification of errors.

The Kenai Peninsula Borough wishes to thank all entities listed below for data provided for this publication.

Alaska Department of Labor and Workforce Development (AK DOL)
City of Homer
City of Kenai
City of Seldovia
City of Seward
City of Soldotna
Kenai Peninsula Borough Finance Department, Sales Tax Division

The writer wishes to thank those persons who gave of their time to review this document to find errors and make suggestions that result in a more professional and accurate document. Those individuals include Jane Stein, Community Leader; Sylvia Vinson, KPB Planning Department; and Betty Glick, former Assembly Member.

What is a “Moving Average Trendline?”

Charts in economic reports frequently include “moving average trendlines.” A description of “trendline” is in order.

The purpose of a trendline is to demonstrate the average of data groupings and how that average relates to averages of similar groupings within the chart.

Imagine that a bar chart illustrates twelve quarters of data. The trendline begins at the fourth entry in the series and marks the point representing the average of the first through the fourth numbers in the series, in this case a 1st, 2nd, 3rd and 4th quarter average value, one year. The trendline continues to the right in the chart. As the trendline reaches the next data point in the series, the trend line will move to the point on the scale representing the average of the second through the fifth entries in the series – still four quarters of data, but this time those values would be the 2nd, 3rd and 4th quarter of the first year plus the 1st quarter of the second year.

The process continues through the chart. As the line moves through the chart, it drops the entry marking the beginning of the previous trend point average, adds the entry just ahead of the previous set of four and indicates the average of the new set of four numbers in the series. The resulting “smoothing” effect allows the reader to more easily see change from one year to the next.

Executive Summary

Reported sales in the Kenai Peninsula Borough (KPB) for second quarter 2006 increased on both gross and taxable levels. Gross sales gained 2.1% over second quarter 2005 while taxable sales grew by 4.4%. On the year-to-date June 30 standard, gross sales are down 0.7% while taxable sales are 6.0% ahead of one year ago. Construction activity has backed off from last year but values remain second highest since 1993. There were 129 permits issued during 2006 compared to 145 during second quarter last year, but volume is third highest on record. As with sales, year-to-date data indicates slight decreases but the overall total is near all time highs.

The KPB labor force and employment in the KPB remain steady near all time highs while the number of unemployed persons is in the low average range. The three factors combine to provide an unemployment rate that is third lowest since 1990, behind 2000 and 2001.

The hydrocarbon industry keeps our interest as companies and political entities struggle to overcome barriers to development and to continued operations. A jack-up drilling rig is expected in Cook Inlet this winter as oil and gas exploration interest continues. Escopeta obtained a Jones Act exemption and the rig should make its way to Cook Inlet so drilling can begin in March. The average daily rate of a jack-up rig at year-end 2004 was \$57,500. The cost of mobilization to Alaska waters is estimated to be between \$12 and \$20 million. Tesoro is adding a \$45 million facility for production of low sulfur diesel, activity that provides a low sulfur diesel product to meet federal mandates that become effective during 2010, and at the same time providing local employment opportunities. Agrium is completing Phase I of a study to determine economic viability of a coal gasification plant that would use coal from the west side of Cook Inlet to provide feedstock for its fertilizer production. Gas supplies have proven to be a stumbling block for the company, which has struggled to remain operational due to lack of feedstock at acceptable prices. Closures have twice been averted as gas supplies were located, although Agrium is operating only two of the four urea plants and two of four ammonia plants.

While the hydrocarbon industry is active year around, the two other major industries in the KPB are more seasonal with the major portion of activity occurring during the coming summer months. Initial reports indicate tourism establishments are starting the summer with strong visitation, providing summer employment opportunities for students and hope for a profitable summer for local retailers. Commercial fishers are hopeful for a strong return of sockeye salmon, though projections indicate that a low return is expected.

The Denali Biotechnologies plant has begun operations that process wild berries into a scientifically based nutraceuticals aid, an addition to the manufacturing sector. Headquarters are located in the KPB but wild blueberries are purchased from native and private landowners across the state.

SALES

Second quarter 2006 gross sales of \$590,693,516 were 2.1% above the \$578,573,148 in sales occurring during 2005, a difference of \$12,120,368, as six of ten sectors reported gains. Taxable sales increased 4.4% from \$220,724,339 during 2005 to \$230,347,945 during the most recent quarter, with eight of ten sectors experiencing increasing sales.

Executive Summary

Quarterly Sales

Gross by Industry. Second quarter 2006 gross sales of \$590,693,516 were 2.1% above the \$578,573,148 in sales occurring during 2005, a difference of \$12,120,368, as six of ten sectors reported gains. The construction sector saw a 16.0% decrease to \$58,729,783. While the drop seems significant, sales were third highest on record following strong sales in both 2003 and 2005 when sales set a new high. Manufacturing was also down, 14.8%, to \$50,496,849 but again total sales were third highest, this time behind 2001 and 2005. Finance, Insurance and Real Estate (FIRE) sales of \$16,125,497 were down 2.8% from the \$16,585,118 reported one year ago. Sale of wholesale goods decreased 0.9% to \$36,103,657.

Gaining 4.1%, gross sales in services reached \$89,681,853, up from one year ago when sales were \$86,181,796. Transportation, Communications and Public Utilities (TCPU) sales increased 4.8%, from \$68,723,636 during second quarter 2005 to \$72,004,359 during the most recent quarter. Retail sales increased 6.3% or \$12,554,480, from \$200,150,931 during second quarter 2005 to \$212,705,411. Agriculture, Forestry and Fishing (AFF) sales increased 9.3% from \$5,742,115 to \$6,278,383. Mining, the only double-digit gainer, saw sales increase 36.4%, as sales grew to \$48,554,473 from \$35,586,431 one year ago. Government sales of \$13,251 are inconsequential. (See page 15 for detail.)

Taxable by Industry. Taxable sales continued upward, increasing 4.4% over second quarter one year ago with total sales of \$230,347,945, a quarterly gain of \$9,623,606. Sales during second quarter 2005 reached \$220,724,339. Retail sales made up 59.6% of total taxable sales, and increased 5.2% over 2005 with sales of \$137,398,293. Last year, second quarter retail sales totaled \$130,554,777. The \$6,843,516 retail sales gain accounted for just over 71% of the overall taxable sales gain. TCPU sales increased 7.8% from \$22,116,281 to \$23,850,568 for a \$1,734,287 gain while sales in the service sector totaled \$47,524,555, increasing 1.3% over second quarter 2005 when sales reached \$46,906,929, a gain of \$617,626. Sale of wholesale goods increased \$606,800 or 9.1% from \$6,698,143 during second quarter 2005 to \$7,304,943 during the most recent second quarter. Taxable sales in the mining sector increased \$131,291 to \$1,161,365, a 12.7% increase. FIRE saw sales grow 1.1% or \$63,049 to \$5,857,751 while AFF sales increased \$62,440 or 3.6% with sales of \$1,799,707. Government sales of \$13,251 are inconsequential.

Two sectors ended the quarter with declining sales when compared to second quarter 2005. Manufacturing sales decreased a total of \$131,563 or 4.8% to \$2,601,637 while construction sales were down \$308,589 or 9.8% to \$2,835,875. (See page 16 for detail.)

Gross by Area. With gross sales up 2.1%, five of six KPB reporting areas experienced gains to total \$590,693,516 for the quarter. Soldotna sales increased 11.4% to \$97,633,142, a gain of \$9,969,372, with strength in construction sales. Kenai sales increased 3.8% to \$106,342,297 while sales outside the incorporated cities reached \$248,779,184, a 3.0% gain. Seldovia sales increased 0.9% to \$2,139,811 while Homer was nearly stable as sales increased 0.01% or \$10,462 to \$86,213,651.

Executive Summary

Seward, the only region with declining sales, had sales of \$49,585,431, down 15.2% from the \$58,467,271. However, second quarter 2005 sales were exceptional and the 2006 sales total is second high on record. (See detail on page 17.)

Taxable by Area. As with gross sales, only one of the six regions experienced declines for the quarter as taxable sales across the KPB totaled \$230,347,945, a gain \$9,623,606 over second quarter 2005. All changes were single-digit gains or declines with a 4.4% KPB gain. Kenai sales increased 8.7% from \$37,426,438 to \$40,691,796. Soldotna's \$55,160,410 in sales marked a 5.7% increase over second quarter 2005 when sales reached \$52,171,825. Sales in the Other KPB region grew by 4.0% to total \$65,897,133, increasing from \$63,332,980. Seward sales increased from \$25,367,609 to \$26,361,494, a 3.9% gain. Lastly, Seldovia sales reached \$943,499, a 1.2% increase over 2005 second quarter sales of \$932,141.

Homer experienced a decline in quarterly taxable sales, which total \$41,293,613, down 0.5% from \$41,493,346 one year ago, and second highest on record. (See detail on page 18.)

Year-to-Date 6/30 Sales

Gross by Industry. Year-to-date June 30 sales of \$975,707,556 were less than one year ago when sales reached \$982,799,753. The 0.7% drop is equivalent to \$7,092,197 in sales. Five of ten sectors had decreased reported sales with change ranging from a 23.1% decline in manufacturing to 23.6% growth in mining. Mining sales increased from \$75,418,040 to \$93,245,103 or \$17,827,063. Retail sales increased \$23,372,881 or 7.1% from \$331,370,411 to \$354,743,292. FIRE sales increased 6.8% from \$28,532,104 to \$30,463,662, a \$1,931,558 gain. Sales in the service sector grew 3.6% or \$4,744,592 as sales increased from \$132,327,209 to \$137,071,801. Inconsequential government sales of \$24,499 were up 3.3%.

Five sectors had declining sales, three of them in double-digit range. TCPU sales were down 2.4% to \$124,008,966 while AFF sales dropped 2.8% to \$8,472,750. Sale of wholesale goods decreased 15.5% to \$62,251,763 from \$73,648,629 while construction sales decreased 16.6% from \$112,342,756 to \$93,671,302. Sales in manufacturing were \$21,553,472 less than one year ago, reaching \$71,754,418, a 23.1% decrease. Manufacturing sales year-to-date June 30, 2005 totaled \$93,307,890. (See detail on page 19.)

Taxable by Industry. Eight of ten industry sectors report sales gains during the first six months of 2006 over those of 2005 with sales of \$387,155,622. The large retail sector grew by \$13,539,826 in taxable sales, 6.3%, to total \$229,925,096. TCPU sector sales increased \$5,183,583 or 11.5%, reaching \$50,378,040. Services grew \$1,748,844 or 2.6% to \$68,279,090. The \$1,382,818 increase in sale of wholesale goods brought sales to \$13,704,515 for an 11.2% increase. The \$364,689 increase in FIRE sales marked a 3.5% gain, with sales increasing to \$10,887,013 while AFF sales increased \$166,422 or 6.2% to total \$2,852,855 for the first two quarters of 2006. Lastly, government sales increased 3.3% to \$24,499.

Only the manufacturing and construction sectors marked quarterly sales declines. Construction sales topped out at \$4,931,116, a 6.2% decrease while manufacturing sales totaled \$3,984,540, down 2.3% from one year ago. (See detail on page 20.)

Executive Summary

Gross by Area. Year to date June 30 sales were marked by increases in three areas and declining sales in three, resulting in a 0.7% KPB decrease. Soldotna sales gained 10.7% or \$16,455,787 to reach \$170,095,199. Seldovia's gain followed with 8.1% growth to \$3,656,049. Homer also had a sales increase, 3.1%, for the first half of 2006 with sales increasing \$4,304,112 and reaching \$142,411,646.

Sales in the Other KPB area declined \$5,733,794 to \$418,961,495, a 1.4% drop. Kenai sales, \$169,357,207, were down 4.9% or \$8,681,938 from one year ago. Lastly, Seward sales declined 16.1% or \$13,710,144 to \$71,225,960. (See detail on page 21.)

Taxable by Area. All areas of the KPB saw taxable sales increase as the KPB gained 6.0% overall. Kenai, with the greatest percentage increase, saw sales increase \$5,860,361 or 8.8%, to total \$72,806,826. Soldotna sales, \$97,326,488, were 7.1% greater than the \$90,905,994 in sales reported last year. Other KPB sales also increased, 7.0%, moving upwards from \$104,468,785 to \$111,784,273, gaining \$7,315,488. Seldovia taxable year-to-date sales increased 4.9% to \$1,579,311, gaining \$74,153. Seward taxable sales gained 3.0% over a year ago with sales of \$36,523,458, compared to \$35,458,594 a year ago. Homer sales gained 2.0% to \$67,135,266 from \$65,829,289 a year ago, increasing \$1,305,977. (See detail on page 22.)

Annual Sales

KPB 2005 annual gross sales of \$2,551,424,605 were 9.4% above those of 2004 as nine of ten sectors had improved sales, five with double-digit growth. Five of the six reporting areas had increased sales for the year.

Taxable sales increased 5.8% from 2004 to 2005 with sales of \$825,606,495 as seven sectors reported increased sales while three had declining sales. As with gross sales, all but one reporting area had increased taxable sales for the year.

Gross by Industry. KPB annual gross sales increased 9.4% during 2005 over 2004 sales, with all reported sales reaching \$2,551,424,605, the second year to pass the \$2 billion mark. The largest percentage gain came in TCPU with a 33.0% increase to \$257,837,257 in sales. The AFF sector gained 21.9% with sales totaling \$33,688,173 and the construction sector was not far behind, gaining 21.1% to total \$287,397,573. Manufacturing sales increased 16.2% or \$42,921,977 to \$307,865,301 and mining sector sales gained 5.0% to total \$176,742,110, a gain of \$11,387,999. The large retail sector increased sales by 6.9% or \$34,749,779 to reach a total of \$734,600,440. FIRE sales increased 3.9% and service sales increased 3.8% with reported sales of \$67,222,418 and \$323,040,441, respectively. The inconsequential \$38,807 in government sales marked a 10.5% gain.

The only declining sector, wholesale goods, saw sales drop 1.0% or \$3,611,833 to \$362,992,085, down from \$366,603,918 one year earlier. (See detail on page 23.)

Taxable by Industry. KPB annual taxable sales increased 5.8% from 2004 to 2005, totaling \$825,606,495, a gain of \$45,033,429. As can be expected in the large sector, retail sales had the largest monetary increase, \$28,515,964 or 6.2%, reaching \$490,159,639 or 59.4% of the 2005 KPB total. TCPU had the second largest monetary gain, up \$8,973,009 or 10.8%, to total

Executive Summary

\$91,686,098, up from \$82,713,089 during 2004. Increasing by \$7,289,011 or 4.7%, sales in the service sector grew from \$155,208,927 during 2004 to \$162,497,938 during 2005. Increasing \$666,271, sale of wholesale goods grew 2.5% to total \$26,957,039 while AFF sales increased \$477,935 to total \$6,003,178, an 8.7% gain. FIRE sales increased to \$22,824,791 a gain of \$273,750 or 1.2%. Government's 10.8% sales increase is inconsequential at \$38,807.

Mining sales decreased \$1,015,183 or 18.5% to \$4,487,117, down from \$5,502,300. Sales in the manufacturing sector decreased \$128,539 or 1.3% while construction sales declined \$22,556 or 0.2% with sales totaling \$9,731,407 and \$11,220,481, respectively. (See detail on page 24.)

Gross by Area. KPB 2005 sales grew by 9.4% as five of six areas reported increased sales. Kenai gross sales expanded 14.3%, reaching \$464,709,325 for the year due in part to strength in the TCPU sector. This marks a \$58,130,936 increase. Seward, with \$189,280,313 in sales, marked a 13.9% gain over the \$166,196,695 gross sales reported for 2004. Sales in the Other KPB region increased 8.9% to \$1,196,399,603 while Homer sales gained 6.8% to reach \$310,198,044. Soldotna sales totaled \$383,967,628 for the year gaining 6.3% or \$22,711,369. (See detail on page 25.)

Taxable by Area. As with gross sales, 2005 taxable sales rose in all but one area, increasing 5.8% to a total of \$825,606,495. Seward, the only double-digit gainer, increased 10.1% to \$88,003,759. Other KPB sales gained 6.6% to total \$232,880,196 followed closely by Soldotna where sales increased 5.6% to \$211,333,890. Homer and Kenai each had taxable sales increases of 4.1% as Homer sales reached \$145,704,361 and Kenai total taxable sales were \$144,303,693.

Seldovia was the only area with decreasing sales, down 0.2% to \$3,380,596 in reported sales. (See detail on page 26.)

CONSTRUCTION PERMITTING

The KPB does not require building permits therefore activity presented in this section does not show all activity within the KPB. Building projects permitted within the five cities that do require permits are shown. Missing data would include construction projects within the KPB but outside the cities of Homer, Kenai, Seldovia, Seward and Soldotna as well as road construction projects, other public works projects, and signage permitting.

Second quarter 2006 values and volume of permitting activity each dropped back slightly from the record setting levels of 2005 with 135 permits being issued during 2006 with a total assessed value of \$21,127,200.

Quarterly Permitting

By Area, Value. KPB total assessed permit values during the second quarter of 2006 was \$21,127,200, just 3.4% less than the 2005 total of \$21,860,075. Homer and Soldotna combined to provide 69.5% of quarterly value, issuing permits totaling \$7,467,100 and \$7,231,328, respectively. Soldotna's total permit value was 5.8% greater than one year ago while Homer's total dropped from the high of \$11,246,000 last year, a 33.6% decrease. Kenai issued

Executive Summary

\$4,157,100 in permit value, a 62.6% gain over 2005 and 19.7% of the KPB quarterly total. Seward issued \$2,184,672 in permit values for 10.3% of the total and 188.0% greater than one year ago. Seldovia issued building permits with a total assessed value of \$87,000. (See detail on page 31.)

By Area, Volume. There were 135 permits issued in the KPB as of June 30, 2006, ten fewer than the 145 permitted during second quarter 2005. Kenai issued 42 permits, nine more than one year ago, and 31.1% of KPB's total. Homer issued 39 permits, eight fewer than one year ago and 28.9% of the total. Activity in Soldotna decreased from 40 to 25, a drop of 37.5% for the quarter and 18.5% of KPB activity, while Seward was increased from 19 to 23 permits for 17.0%. Lastly, Seldovia activity was stable, issuing 6 permits with 4.4% of Borough activity. (See detail on page 32.)

By Type, Value. As total permit values decreased 3.4%, one permit category saw decreasing total value while three had increases. New residential construction projects within the cities increased 35.2% in assessed value from \$7,560,499 during second quarter 2005 to \$10,219,599 during the same quarter of 2006, a 35.2% gain and 48.4% of the total. Commercial alteration/addition permitting grew by 22.1% as total values rose from \$1,589,958 to \$1,941,323. Residential alteration/addition permitting increased 2.2% from \$812,470 to \$830,630. New commercial permit values, the only category to decrease, provided 38.5% of value with a total of \$8,135,648, down from \$11,897,148 during second quarter 2005. (See detail on page 33.)

By Type, Volume. While values increased in three of four construction permit categories, volume decreased in three of those four categories, indicating greater average value per permit. New residential activity increased 16.3% from 49 to 57 permits when comparing second quarters of 2005 and 2006. Residential alteration/addition activity dropped 13.0% from 46 to 40 permits. Down 18.5%, new commercial projects decreased from 27 to 22 permits while alteration/addition projects decreased from 23 to 16. (See detail on page 34.)

Year-to-Date Permitting

Year-to-date June 30 permit values decreased 0.2% from the 2005 level of \$28,000,330 to \$27,930,358. The 1995 record setting year occurred when the Seward SeaLife Center was permitted and values totaled \$44,775,955. Permit volume of 2005 dropped from the 2004 high of 202 permits to 176, but was second highest volume on record.

By Area, Value. Homer issued permits totaling \$10,738,100 for 38.4% of the total KPB value during the first half of 2006. Soldotna followed with \$9,347,769 and 33.5% of the total. Kenai, issuing 17.6% of the KPB value, permitted \$4,920,600 in construction projects, while Seward issued permits with assessed values totaling \$2,806,889 for 10.0%. Seldovia permits totaled \$117,000 in assessed value. (See detail on page 35.)

By Area, Volume. Year-to-date June 30 permitting decreased 12.9% from 2005 to 2006 as total activity dropped from 202 to 176 permits. Kenai's 56 permits surpassed the 43 permits issued during the first six months of 2005 by 30.2% and provided 31.8% of KPB activity to date. Homer issued 53 permits, 18.5% less than the 65 issued a year ago, and 30.1% of the total. The 30 permits issued in Soldotna, was 46.4% less than the 56 issued last year, while Seward, also

Executive Summary

issuing 30 permits, dropped from 31 permits year-to-date 2005, a 3.2% decrease. They each contributed 17.0% with Seldovia's 4.0% making up the total. Seldovia was stable, issuing seven permits during the first half of the year during both 2005 and 2006. (See detail on page 36.)

By Type, Value. Assessed permit values decreased 0.2% from \$28,000,330 to \$27,930,358 as new residential permit values increased 14.5% from \$10,898,855 to \$12,476,630 and provided 44.7% of year-to-date value. Commercial alteration/addition permit values gained 50.1%, increasing from \$3,666,927 to \$5,504,040 year-to-date June 30, 2006, providing 19.7% of the value. Total assessed values of new commercial projects dropped 25.7% from \$12,206,148 to \$9,074,058 while residential alteration/addition projects decreased 28.7% from \$1,228,400 to \$875,630. New commercial projects provided 32.5% of the value while residential alteration/addition rounded out the total with 3.1%. (See detail on page 37.)

By Type, Volume. Of the 176 permits issued during the first two quarters of 2006, 65.4% were for residential projects. Seventy permits were issued for new homes and 45 were for residential alterations or additions. Commercial alterations added 35 permits, 19.9% of the total and new commercial permits provided the remaining 26 permits, 14.8%. New residential permitting was the only category with increased activity, 4.5%. Residential alterations were down 25.0%, new commercial activity dropped 21.2% and commercial activity was down 16.7%. (See detail on page 38.)

Annual Construction - Year 2005

Construction permits are required by KPB cities, but not by the KPB, resulting in incomplete construction activity data. Permit values during 2005 totaled \$44,733,803, a 69.1% decrease from record setting 2004 activity when total assessed values reached \$84,041,457. Both Homer and Soldotna had exceptional activity, but topping the list were the addition to Soldotna's Central Peninsula General Hospital, Fred Meyer's expansion, and Trustworthy Hardware's new facility. There were 338 permits issued during 2005, 8.3% more than the 312 issued during 2004, and second highest on record. There were 351 permits issued during 2002.

By Area, Value. Homer's \$21,611,400 in construction permit assessed values provided 48.3% of KPB 2005 annual value, but was 10.2% less than during 2004. Soldotna values decreased 69.1% but provided 25.7% of the total, issuing \$11,509,360 in permits. Kenai values totaled \$8,237,900, increasing 72.1% for the year from \$4,786,550, and providing 18.4% of the annual total. Seward permit values dropped 83.8% to \$2,863,143, providing 6.4% of the KPB total. Seldovia's \$512,000 value provided the remaining 1.1%. (See detail on page 39.)

By Area, Volume. During 2005 Homer issued 103 of 338 permits, 30.5% of the KPB total. Kenai issued 90 permits while Soldotna issued 81 permits, 26.6% and 24.0%, respectively. Kenai's total reflected 13.9% growth while Soldotna showed a 20.9% increase. Seward issued 54 permits, identical to 2004 and 16.0% of the total while Seldovia's 10 permits, 3.0% of the KPB total, was 150.0% greater than one year ago. (See detail on page 40.)

By Type, Value. After strong construction activity during 2004, it is not surprising that values were down in three of four categories for 2005. Only new residential activity experienced an increased total value. The 2005 total assessed permit value was \$44,733,803. New projects

Executive Summary

provided 82.7% of permit activity with commercial and residential permits providing 43.0% and 39.7% of the total, respectively. New commercial values reached \$19,217,548, down 65.7% from the exceptional 2004 value of \$56,079,343 while new residential permit values totaled \$17,749,648, up 11.4% from \$15,935,344 one year ago. Commercial alteration/addition permit values totaled \$5,531,479 for 12.4% of the total. Residential alteration/addition permits added \$2,235,128 for 5.0% of the total. Commercial alteration/addition permit values dropped 39.5% while residential alteration/addition values were down 22.4%. (See detail on page 41.)

By Type, Volume. Total 2005 permit activity increased 8.3% to 338 permits from 312 during 2004. New residential activity increased 18.1% from the 94 permits issued last year to 111 permits during 2005. There were 106 residential alteration/addition permits issued, 10.4% more than during 2004. New commercial activity increased from 42 to 46 permits, 9.5%, while commercial alteration/addition activity dropped, 6.3%, from 80 to 75 permits. (See detail on page 42.)

EMPLOYMENT

Employment data has been revised and a change in labor force statistics calculations for boroughs and census areas make data prior to 2000 not comparable with data from 2000 forward.

KPB's labor force remains strong, with annual peaks during the busy summer months. The 26,791 available workers during June was down 64 persons from June 2005. The May labor force of 25,215 was 39 workers less than one year ago. April available workers numbered 23,790, this was 91 less than April of 2005. Although the total available workers were down each month of the quarter, the total labor force remains near all time highs.

There were 1,929 persons listed as unemployed in the KPB during June 2006, 86 fewer than June 2005. May unemployment was reported at 2,013; that is 71 more than during 2005. April saw 2,310 persons unemployed, 79 more than April 2005. All three months were slightly above record lows, which generally occurred during 2001.

KPB's 2005 unemployment rates for second quarter increased the first two months but dropped from 7.5% June 2005 to 7.2% during June 2006. June rates for the past four years decreased from 9.5% in 2003 to 9.0% during 2002, down to 7.5% last year and on down to 7.2% this year.

2006 employment was down for April, 370 persons, and May, 110 persons, but June saw a reversal as 24,862 persons were employed. This is 22 greater than during June of 2005 when 24,840 persons were employed in the KPB. (See detail on pages 47-51.)

POPULATION

The Kenai Peninsula population is estimated at 51,268 persons, a 0.6% annual gain. Four of the six incorporated cities marked gains with Homer increasing 1.9% to 5,435; Seldovia gained 9.1% to 287 and Seward increased 2.6%, to 2,606 persons. Soldotna's population grew 2.7% to 3,869. Kenai lost 0.5% with a population of 6,777 while Kachemak City lost 3.8% to 457 persons. Alaska's population was estimated at 663,661 for 2005, an 8.9% increase for the year. (See page 54 for detail.)

KPB Sales

Sales tax records provide data useful for predicting economic trends and provide a basis for administrative decisions. Data collected are specific to the area collecting and reporting sales; but, by combining data from reporting communities, KPB trends can be determined. Routinely, three years or twelve quarters of information are revised each quarter. Sales data is provided by the KPB Finance Department, Sales Tax Division and includes detail from Homer, Kenai, Seldovia, Seward, Soldotna and “Other KPB” areas. “Other KPB” indicates areas within the KPB but outside the boundaries of five incorporated cities. It also includes Kachemak City, which does not impose a sales tax. The 2% KPB sales tax is included in the city rates listed below, with revenues dedicated to funding the KPB school district. The balance is the tax imposed by each city with revenues being managed by that city.

The KPB does not provide an incentive for reporting non-taxable sales, resulting in incomplete Gross Sales data.

6.5%	6.0%	5.0%	4.0%	2.0%
Homer	Seward	Kenai	Seldovia	Other KPB
Seldovia		Soldotna	(October - March)	
(April - September)				

Gross and Taxable Sales data are generally received quarterly through Sales Tax Returns from businesses within the KPB. Some businesses are required to report monthly while others with very low taxable sales may report on an annual basis. Sales that are exempt from sales tax include:

- Sales outside the borough;
- Sales for resale;
- Sales to government agencies;
- Sales to tax exempt organizations; and
- Sales in excess of \$500.

Industry abbreviations used in sales data may include the following:

- AFF- Ag, Forest, Fish - Agriculture, Forestry and Fisheries - includes fish buyers;
- Min- Mining - includes Oil & Gas extraction and production;
- Const- Construction Construction
- Manu- Manufacturing - includes Oil & Gas Manufacturing and Fish Processing;
- TCPU- Trans, Comm, Pub Util - Transportation, Communications and Public Utilities;
- Whole- Wholesale - Wholesale Trade;
- Retail- Retail - Retail Trade;
- FIRE- Finance, Ins, Real Estate Finance, Insurance and Real Estate;
- Serv- Services Services
- Govt- Government - Public Administration, Education and Services.

KPB Sales

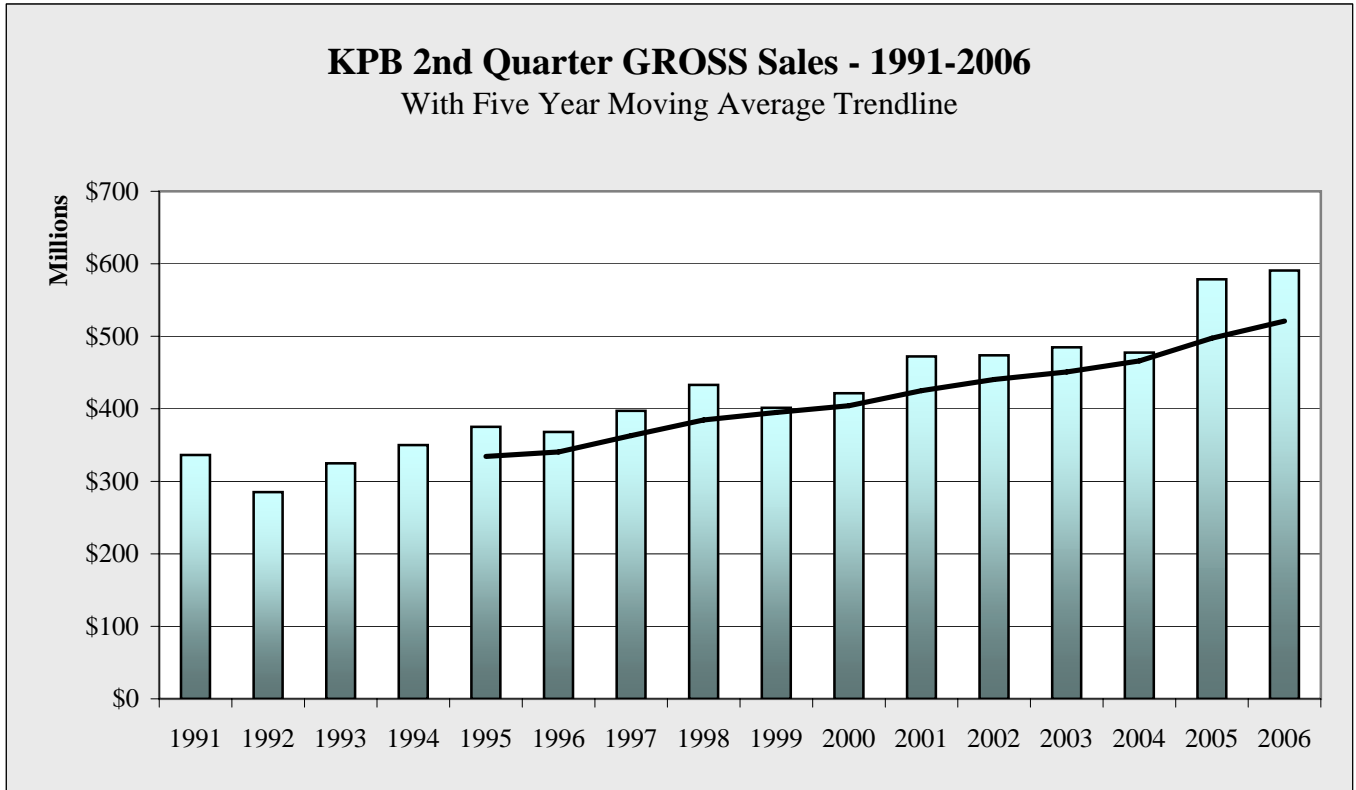

Chart 1.1

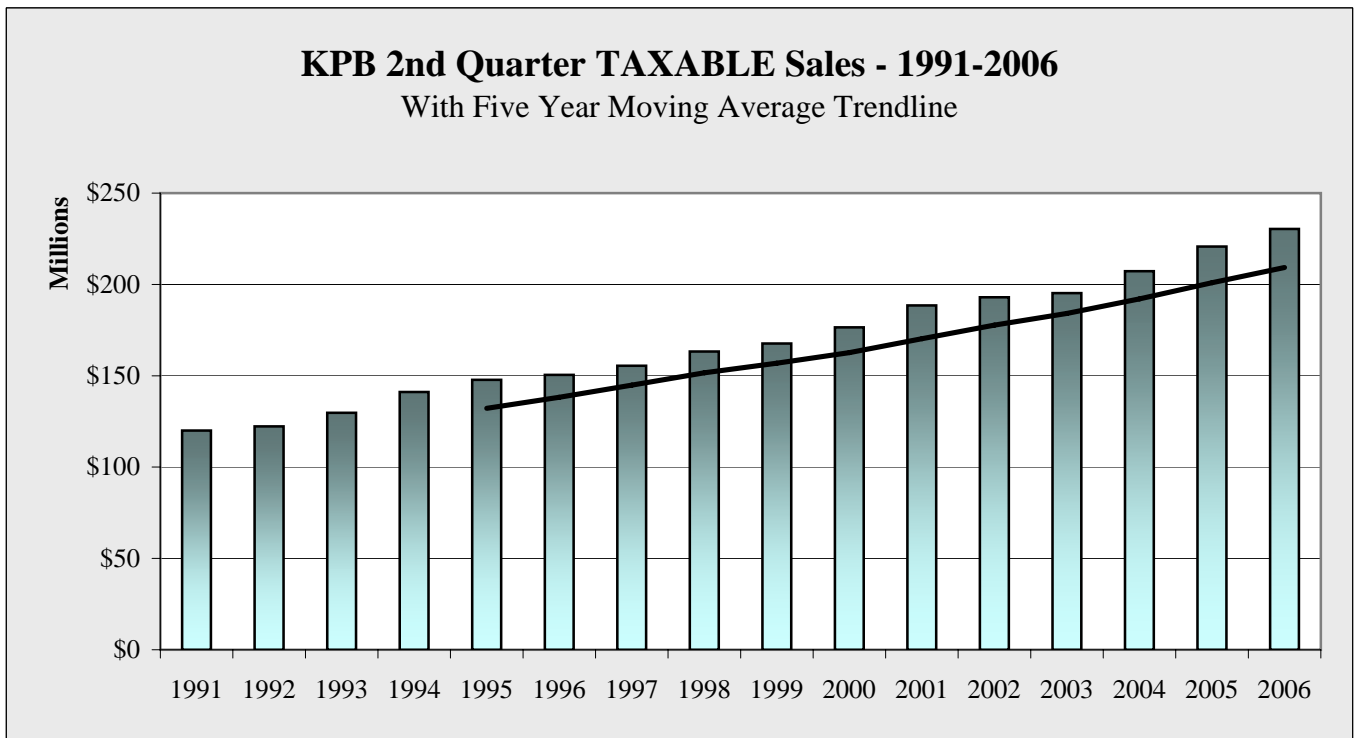

Chart 1.2

KPB Sales

KPB 2nd Quarter GROSS Sales by INDUSTRY - 2001-2006 - in \$							
	2001	2002	2003	2004	2005	2006	Annual Change
Ag, Forest, Fish	2,803,392	2,856,503	4,045,723	3,911,032	5,742,115	6,278,383	9.3%
Mining	26,110,361	29,861,507	25,083,685	32,098,347	35,586,431	48,554,473	36.4%
Construction	51,568,925	49,802,682	67,679,718	42,316,016	69,893,319	58,729,783	-16.0%
Manufacturing	56,672,953	44,663,448	34,259,747	15,540,229	59,287,458	50,496,849	-14.8%
Trans, Comm, Pub Util	40,127,980	42,378,179	38,841,966	48,292,512	68,723,636	72,004,359	4.8%
Wholesale	44,103,011	46,538,996	50,841,751	50,630,515	36,413,842	36,103,657	-0.9%
Retail	166,794,245	165,284,611	170,701,632	187,668,631	200,150,931	212,705,411	6.3%
Finance, Ins, Real Estate	13,531,404	14,809,716	15,377,000	14,525,303	16,585,118	16,125,497	-2.8%
Services	70,429,963	77,618,394	77,932,301	82,638,666	86,181,796	89,681,853	4.1%
Government	5,238	7,859	8,680	8,521	8,502	13,251	55.9%
Total	472,147,472	473,821,895	484,772,203	477,629,772	578,573,148	590,693,516	2.1%
Annual Change		0.4%	2.3%	-1.5%	21.1%	2.1%	

Table 1.1

KPB 2nd Quarter GROSS Sales Ten Year Change by INDUSTRY - 1996-2006 - in \$				
			10 Year Change	
	1996	2006	Percentage	Numerical
Ag, Forest, Fish	8,165,736	6,278,383	-23.1%	-1,887,353
Mining	19,302,502	48,554,473	151.5%	29,251,971
Construction	34,818,817	58,729,783	68.7%	23,910,966
Manufacturing	45,455,668	50,496,849	11.1%	5,041,181
Trans, Comm, Pub Util	34,517,817	72,004,359	108.6%	37,486,542
Wholesale	34,519,170	36,103,657	4.6%	1,584,487
Retail	125,092,467	212,705,411	70.0%	87,612,944
Finance, Ins, Real Estate	14,856,259	16,125,497	8.5%	1,269,238
Services	51,272,922	89,681,853	74.9%	38,408,931
Government	2,363	13,251	460.8%	10,888
Total	368,003,721	590,693,516	60.5%	222,689,795

Table 1.2

KPB 2nd Quarter GROSS Sales One Year Change by INDUSTRY - 2005-2006 - in \$				
			1 Year Change	
	2005	2006	Percentage	Numerical
Ag, Forest, Fish	5,742,115	6,278,383	9.3%	536,268
Mining	35,586,431	48,554,473	36.4%	12,968,042
Construction	69,893,319	58,729,783	-16.0%	-11,163,536
Manufacturing	59,287,458	50,496,849	-14.8%	-8,790,609
Trans, Comm, Pub Util	68,723,636	72,004,359	4.8%	3,280,723
Wholesale	36,413,842	36,103,657	-0.9%	-310,185
Retail	200,150,931	212,705,411	6.3%	12,554,480
Finance, Ins, Real Estate	16,585,118	16,125,497	-2.8%	-459,621
Services	86,181,796	89,681,853	4.1%	3,500,057
Government	8,502	13,251	55.9%	4,749
Total	578,573,148	590,693,516	2.1%	12,120,368

Table 1.3

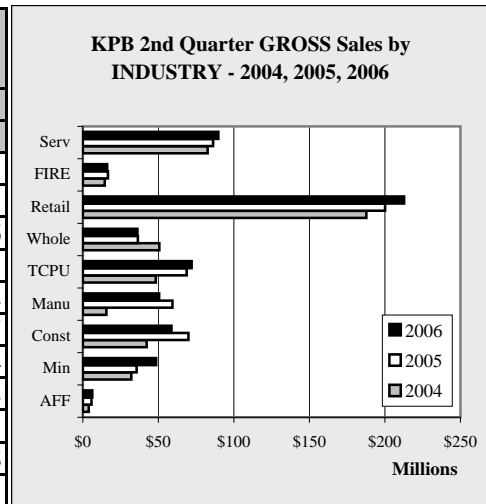

Chart 1.3

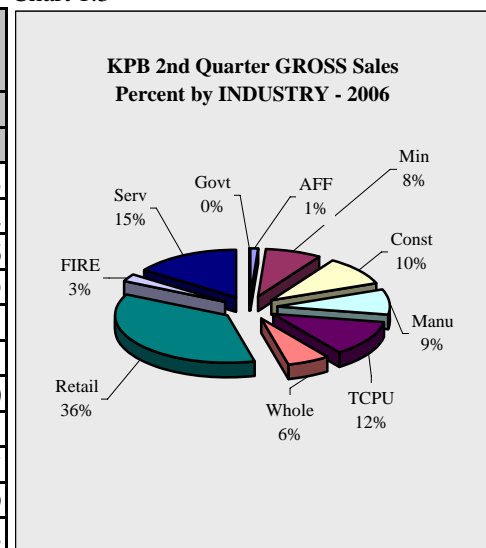

Chart 1.4

KPB Sales

KPB 2nd Quarter TAXABLE Sales by INDUSTRY - 2001-2006 - in \$							
	2001	2002	2003	2004	2005	2006	Annual Change
Ag, Forest, Fish	1,401,861	1,423,988	1,577,278	1,674,503	1,737,267	1,799,707	3.6%
Mining	1,349,445	1,484,251	1,170,493	1,082,504	1,030,074	1,161,365	12.7%
Construction	2,526,383	2,674,603	3,126,868	2,917,698	3,144,464	2,835,875	-9.8%
Manufacturing	2,885,132	2,791,765	2,607,213	2,737,701	2,733,200	2,601,637	-4.8%
Trans, Comm, Pub Util	19,064,716	21,477,202	20,321,138	19,475,240	22,116,281	23,850,568	7.8%
Wholesale	5,794,250	5,716,265	6,337,983	6,600,388	6,698,143	7,304,943	9.1%
Retail	108,655,727	109,881,835	112,406,985	122,332,545	130,554,777	137,398,293	5.2%
Finance, Ins, Real Estate	5,949,812	6,084,401	5,999,648	5,773,373	5,794,702	5,857,751	1.1%
Services	40,842,035	41,449,302	41,657,244	44,641,440	46,906,929	47,524,555	1.3%
Government	5,238	7,859	8,680	8,521	8,502	13,251	55.9%
Total	188,474,599	192,991,471	195,213,530	207,243,913	220,724,339	230,347,945	4.4%
Annual Change		2.4%	1.2%	6.2%	6.5%	4.4%	

Table 1.4

KPB 2nd Quarter TAXABLE Sales Ten Year Change by INDUSTRY - 1996-2006 - in \$				
			10 Year Change	
	1996	2006	Percentage	Numerical
Ag, Forest, Fish	952,619	1,799,707	88.9%	847,088
Mining	1,044,188	1,161,365	11.2%	117,177
Construction	2,226,462	2,835,875	27.4%	609,413
Manufacturing	2,391,825	2,601,637	8.8%	209,812
Trans, Comm, Pub Util	16,170,626	23,850,568	47.5%	7,679,942
Wholesale	4,994,458	7,304,943	46.3%	2,310,485
Retail	86,380,795	137,398,293	59.1%	51,017,498
Finance, Ins, Real Estate	4,765,255	5,857,751	22.9%	1,092,496
Services	31,529,423	47,524,555	50.7%	15,995,132
Government	2,363	13,251	460.8%	10,888
Total	150,458,014	230,347,945	53.1%	79,889,931

Table 1.5

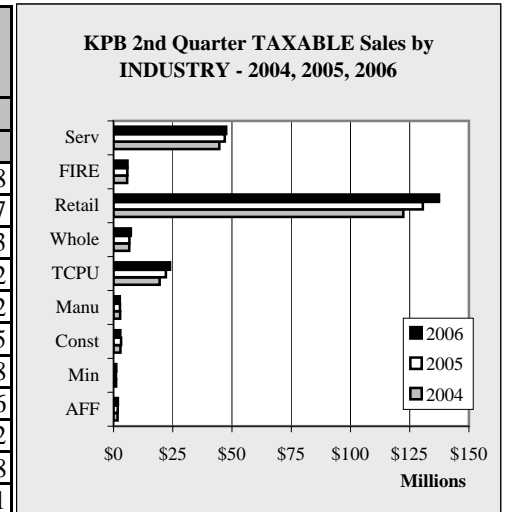

Chart 1.5

KPB 2nd Quarter TAXABLE Sales One Year Change by INDUSTRY - 2005-2006 - in \$				
			1 Year Change	
	2005	2006	Percentage	Numerical
Ag, Forest, Fish	1,737,267	1,799,707	3.6%	62,440
Mining	1,030,074	1,161,365	12.7%	131,291
Construction	3,144,464	2,835,875	-9.8%	-308,589
Manufacturing	2,733,200	2,601,637	-4.8%	-131,563
Trans, Comm, Pub Util	22,116,281	23,850,568	7.8%	1,734,287
Wholesale	6,698,143	7,304,943	9.1%	606,800
Retail	130,554,777	137,398,293	5.2%	6,843,516
Finance, Ins, Real Estate	5,794,702	5,857,751	1.1%	63,049
Services	46,906,929	47,524,555	1.3%	617,626
Government	8,502	13,251	55.9%	4,749
Total	220,724,339	230,347,945	4.4%	9,623,606

Table 1.6

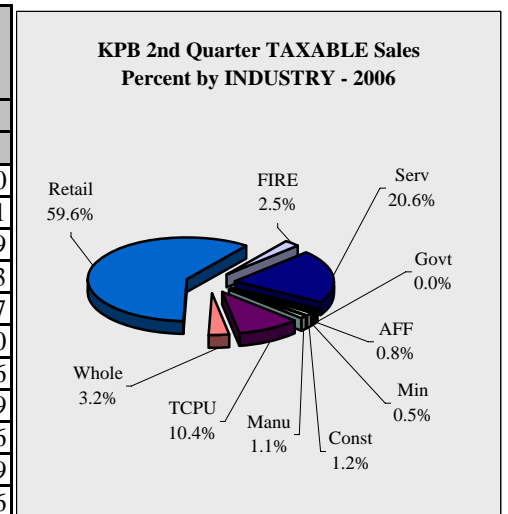

Chart 1.6

KPB Sales

KPB 2nd Quarter GROSS Sales by AREA - 2001-2006 - in \$							
	2001	2002	2003	2004	2005	2006	Annual Change
Homer	56,857,475	68,675,179	75,287,944	75,752,214	86,203,189	86,213,651	0.01%
Kenai	76,673,936	67,929,291	67,434,799	80,387,362	102,467,945	106,342,297	3.8%
Seldovia	1,473,305	1,155,055	1,629,455	1,971,670	2,120,534	2,139,811	0.9%
Seward	44,452,278	40,385,376	46,984,153	42,749,272	58,467,271	49,585,431	-15.2%
Soldotna	75,042,511	79,762,672	85,228,244	89,310,129	87,663,770	97,633,142	11.4%
Other KPB	217,647,967	215,914,322	208,207,608	187,459,125	241,650,439	248,779,184	3.0%
Total	472,147,472	473,821,895	484,772,203	477,629,772	578,573,148	590,693,516	2.1%
Annual Change		0.4%	2.3%	-1.5%	21.1%	2.1%	

Table 1.7

KPB 2nd Quarter GROSS Sales Ten Year Change by AREA - 1996-2006 - in \$				
			10 Year Change	
	1996	2006	Percentage	Numerical
Homer	53,691,216	86,213,651	60.6%	32,522,435
Kenai	59,006,953	106,342,297	80.2%	47,335,344
Seldovia	1,406,053	2,139,811	52.2%	733,758
Seward	35,228,909	49,585,431	40.8%	14,356,522
Soldotna	54,086,799	97,633,142	80.5%	43,546,343
Other KPB	164,583,791	248,779,184	51.2%	84,195,393
Total	368,003,721	590,693,516	60.5%	222,689,795

Table 1.8

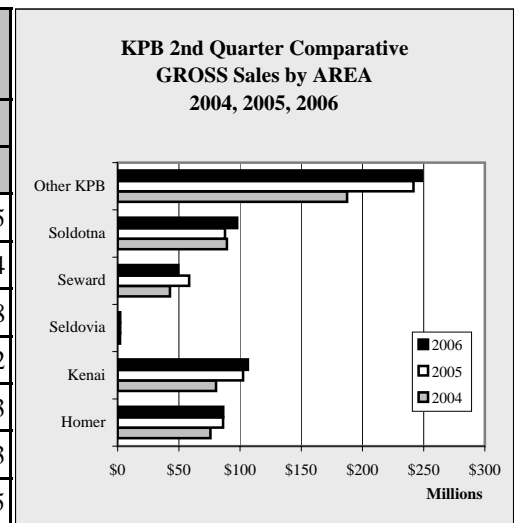

Chart 1.7

KPB 2nd Quarter GROSS Sales One Year Change by AREA - 2005-2006 - in \$				
			1 Year Change	
	2005	2006	Percentage	Numerical
Homer	86,203,189	86,213,651	0.01%	10,462
Kenai	102,467,945	106,342,297	3.8%	3,874,352
Seldovia	2,120,534	2,139,811	0.9%	19,277
Seward	58,467,271	49,585,431	-15.2%	-8,881,840
Soldotna	87,663,770	97,633,142	11.4%	9,969,372
Other KPB	241,650,439	248,779,184	3.0%	7,128,745
Total	578,573,148	590,693,516	2.1%	12,120,368

Table 1.9

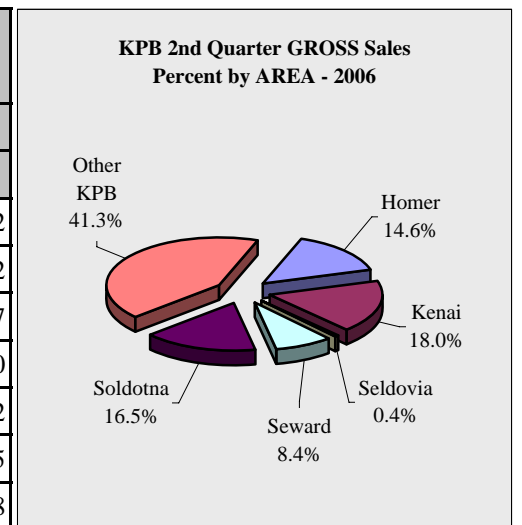

Chart 1.8

KPB Sales

KPB 2nd Quarter TAXABLE Sales by AREA - 2001-2006 - in \$							
	2001	2002	2003	2004	2005	2006	Annual Change
Homer	30,191,477	34,270,923	37,038,468	39,648,524	41,493,346	41,293,613	-0.5%
Kenai	34,988,669	34,624,807	29,812,054	36,263,158	37,426,438	40,691,796	8.7%
Seldovia	956,033	898,830	962,966	939,589	932,141	943,499	1.2%
Seward	21,553,264	22,176,474	22,072,081	22,991,903	25,367,609	26,361,494	3.9%
Soldotna	42,914,074	43,504,958	47,026,667	49,011,743	52,171,825	55,160,410	5.7%
Other KPB	57,871,082	57,515,479	58,301,294	58,388,996	63,332,980	65,897,133	4.0%
Total	188,474,599	192,991,471	195,213,530	207,243,913	220,724,339	230,347,945	4.4%
Annual Change		2.4%	1.2%	6.2%	6.5%	4.4%	

Table 1.10

KPB 2nd Quarter TAXABLE Sales Ten Year Change by AREA - 1996-2006 - in \$				
			10 Year Change	
	1996	2006	Percentage	Numerical
Homer	25,240,189	41,293,613	63.6%	16,053,424
Kenai	29,825,649	40,691,796	36.4%	10,866,147
Seldovia	996,975	943,499	-5.4%	-53,476
Seward	16,410,250	26,361,494	60.6%	9,951,244
Soldotna	32,996,657	55,160,410	67.2%	22,163,753
Other KPB	44,988,294	65,897,133	46.5%	20,908,839
Total	150,458,014	230,347,945	53.1%	79,889,931

Table 1.11

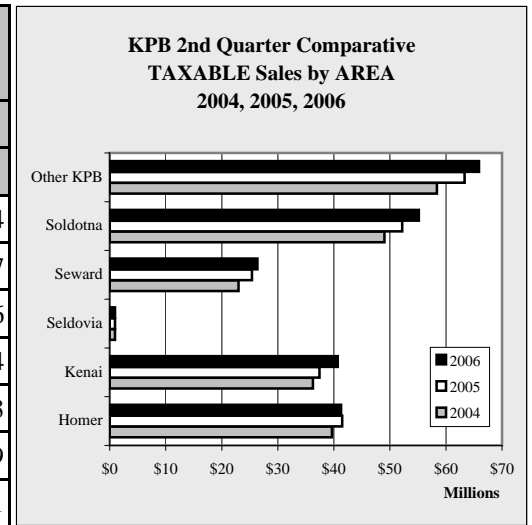

Chart 1.9

KPB 2nd Quarter TAXABLE Sales One Year Change by AREA - 2005-2006 - in \$				
			1 Year Change	
	2005	2006	Percentage	Numerical
Homer	41,493,346	41,293,613	-0.5%	-199,733
Kenai	37,426,438	40,691,796	8.7%	3,265,358
Seldovia	932,141	943,499	1.2%	11,358
Seward	25,367,609	26,361,494	3.9%	993,885
Soldotna	52,171,825	55,160,410	5.7%	2,988,585
Other KPB	63,332,980	65,897,133	4.0%	2,564,153
Total	220,724,339	230,347,945	4.4%	9,623,606

Table 1.12

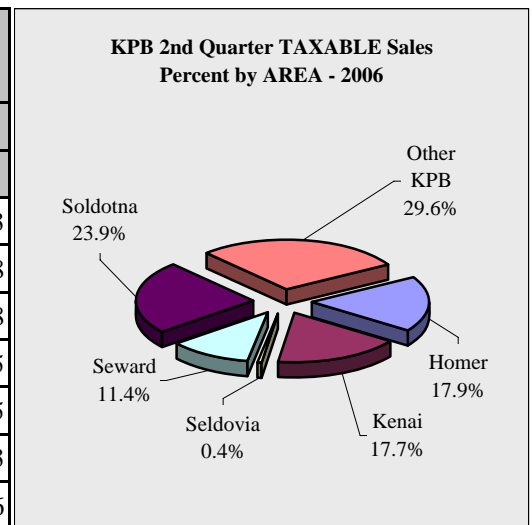

Chart 1.10

KPB Sales

KPB YTD 6/30 GROSS Sales by INDUSTRY - 2001-2006 - in \$

	2001	2002	2003	2004	2005	2006	Annual Change
Ag, Forest, Fish	4,385,438	4,861,344	6,065,662	6,251,958	8,718,221	8,472,750	-2.8%
Mining	54,334,306	64,523,892	44,343,827	71,899,741	75,418,040	93,245,103	23.6%
Construction	91,223,587	92,967,922	110,966,566	70,914,276	112,342,756	93,671,302	-16.6%
Manufacturing	105,149,536	66,005,209	72,836,195	41,647,284	93,307,890	71,754,418	-23.1%
Trans, Comm, Pub Util	78,569,430	83,101,571	77,059,039	87,261,075	127,110,777	124,008,966	-2.4%
Wholesale	80,077,933	83,667,742	86,760,176	92,413,286	73,648,629	62,251,763	-15.5%
Retail	283,285,514	281,185,508	293,817,077	314,474,745	331,370,411	354,743,292	7.1%
Finance, Ins, Real Estate	24,447,401	27,236,429	27,174,457	27,915,345	28,532,104	30,463,662	6.8%
Services	106,708,416	120,859,349	119,516,788	125,734,988	132,327,209	137,071,801	3.6%
Government	11,745	14,559	20,999	22,184	23,716	24,499	3.3%
Total	828,193,306	824,423,525	838,560,786	838,534,882	982,799,753	975,707,556	-0.7%
Annual Change		-0.5%	1.7%	0.0%	17.2%	-0.7%	

Table 1.13

KPB YTD 6/30 GROSS Sales Ten Year Change by INDUSTRY - 1996-2006 - in \$

	10 Year Change			
	1996	2006	Percentage	Numerical
Ag, Forest, Fish	11,129,242	8,472,750	-23.9%	-2,656,492
Mining	38,238,939	93,245,103	143.8%	55,006,164
Construction	60,325,518	93,671,302	55.3%	33,345,784
Manufacturing	83,821,639	71,754,418	-14.4%	-12,067,221
Trans, Comm, Pub Util	68,169,081	124,008,966	81.9%	55,839,885
Wholesale	58,375,837	62,251,763	6.6%	3,875,926
Retail	212,966,728	354,743,292	66.6%	141,776,564
Finance, Ins, Real Estate	26,234,702	30,463,662	16.1%	4,228,960
Services	79,621,019	137,071,801	72.2%	57,450,782
Government	4,281	24,499	472.3%	20,218
Total	638,886,986	975,707,556	52.7%	336,820,570

Table 1.14

KPB YTD 6/30 GROSS Sales by INDUSTRY - 2004, 2005, 2006

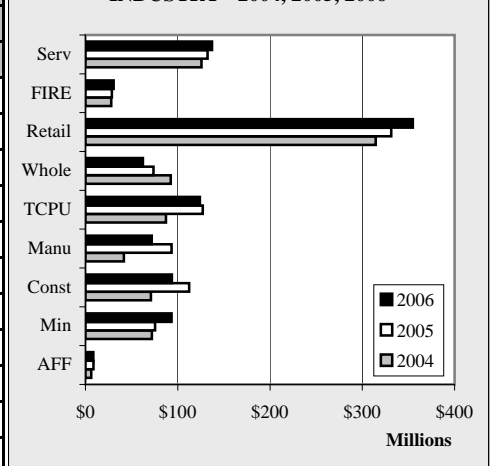

Chart 1.11

KPB YTD 6/30 GROSS Sales One Year Change by INDUSTRY - 2005-2006 - in \$

	1 Year Change			
	2005	2006	Percentage	Numerical
Ag, Forest, Fish	8,718,221	8,472,750	-2.8%	-245,471
Mining	75,418,040	93,245,103	23.6%	17,827,063
Construction	112,342,756	93,671,302	-16.6%	-18,671,454
Manufacturing	93,307,890	71,754,418	-23.1%	-21,553,472
Trans, Comm, Pub Util	127,110,777	124,008,966	-2.4%	-3,101,811
Wholesale	73,648,629	62,251,763	-15.5%	-11,396,866
Retail	331,370,411	354,743,292	7.1%	23,372,881
Finance, Ins, Real Estate	28,532,104	30,463,662	6.8%	1,931,558
Services	132,327,209	137,071,801	3.6%	4,744,592
Government	23,716	24,499	3.3%	783
Total	982,799,753	975,707,556	-0.7%	-7,092,197

Table 1.15

KPB YTD 6/30 GROSS Sales Percent by INDUSTRY - 2006

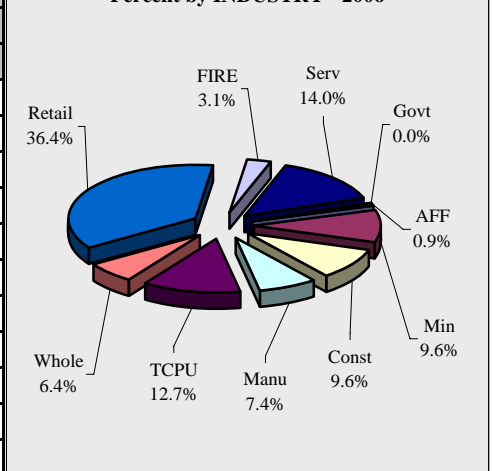

Chart 1.12

KPB Sales

KPB YTD 6/30 TAXABLE Sales by INDUSTRY - 2001-2006 - in \$

	2001	2002	2003	2004	2005	2006	Annual Change
Ag, Forest, Fish	2,130,092	2,220,368	2,340,323	2,563,780	2,686,433	2,852,855	6.2%
Mining	2,577,296	2,966,852	2,404,111	2,130,172	2,117,904	2,188,858	3.4%
Construction	4,393,270	4,687,912	5,178,846	5,127,127	5,254,635	4,931,116	-6.2%
Manufacturing	4,382,690	4,099,509	4,046,100	4,249,831	4,077,603	3,984,540	-2.3%
Trans, Comm, Pub Util	38,384,906	43,051,137	41,971,663	40,498,295	45,194,457	50,378,040	11.5%
Wholesale	10,400,395	10,531,984	11,390,544	12,492,818	12,321,697	13,704,515	11.2%
Retail	182,360,553	186,304,798	192,385,184	205,458,741	216,385,270	229,925,096	6.3%
Finance, Ins, Real Estate	10,939,740	11,563,326	11,334,095	10,713,874	10,522,324	10,887,013	3.5%
Services	58,753,041	60,389,944	60,436,892	63,893,696	66,530,246	68,279,090	2.6%
Government	11,745	14,559	20,999	22,119	23,716	24,499	3.3%
Total	314,333,728	325,830,389	331,508,757	347,150,453	365,114,285	387,155,622	6.0%
Annual Change		3.7%	1.7%	4.7%	5.2%	6.0%	

Table 1.16

KPB YTD 6/30 TAXABLE Sales Ten Year Change by INDUSTRY - 1996-2006 - in \$

			10 Year Change	
	1996	2006	Percentage	Numerical
Ag, Forest, Fish	1,420,357	2,852,855	100.9%	1,432,498
Mining	2,011,937	2,188,858	8.8%	176,921
Construction	3,753,145	4,931,116	31.4%	1,177,971
Manufacturing	3,853,933	3,984,540	3.4%	130,607
Trans, Comm, Pub Util	32,620,823	50,378,040	54.4%	17,757,217
Wholesale	9,517,366	13,704,515	44.0%	4,187,149
Retail	146,402,464	229,925,096	57.1%	83,522,632
Finance, Ins, Real Estate	9,238,030	10,887,013	17.8%	1,648,983
Services	46,773,317	68,279,090	46.0%	21,505,773
Government	4,281	24,499	472.3%	20,218
Total	255,595,653	387,155,622	51.5%	131,559,969

Table 1.17

KPB YTD 6/30 TAXABLE Sales by INDUSTRY - 2004, 2005, 2006

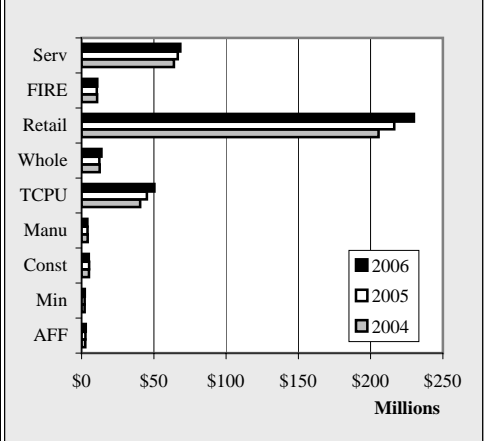

Chart 1.13

KPB YTD 6/30 TAXABLE Sales One Year Change by INDUSTRY - 2005-2006 - in \$

			1 Year Change	
	2005	2006	Percentage	Numerical
Ag, Forest, Fish	2,686,433	2,852,855	6.2%	166,422
Mining	2,117,904	2,188,858	3.4%	70,954
Construction	5,254,635	4,931,116	-6.2%	-323,519
Manufacturing	4,077,603	3,984,540	-2.3%	-93,063
Trans, Comm, Pub Util	45,194,457	50,378,040	11.5%	5,183,583
Wholesale	12,321,697	13,704,515	11.2%	1,382,818
Retail	216,385,270	229,925,096	6.3%	13,539,826
Finance, Ins, Real Estate	10,522,324	10,887,013	3.5%	364,689
Services	66,530,246	68,279,090	2.6%	1,748,844
Government	23,716	24,499	3.3%	783
Total	365,114,285	387,155,622	6.0%	22,041,337

Table 1.18

KPB YTD 6/30 TAXABLE Sales Percent by INDUSTRY - 2006

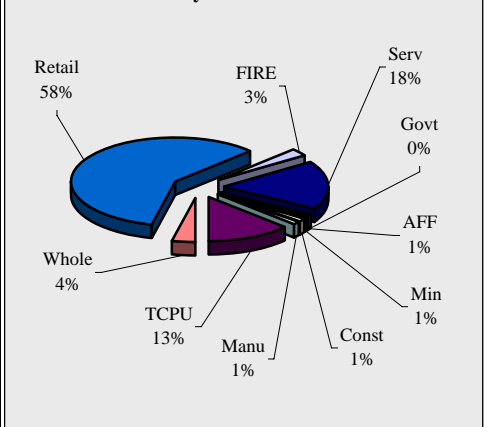

Chart 1.14

KPB Sales

KPB YTD 6/30 GROSS Sales by AREA - 2001-2006 - in \$							
	2001	2002	2003	2004	2005	2006	Annual Change
Homer	97,702,453	112,944,832	126,516,220	123,893,800	138,107,534	142,411,646	3.1%
Kenai	139,092,222	128,525,660	129,585,656	141,470,366	178,039,145	169,357,207	-4.9%
Seldovia	2,372,116	2,166,767	2,476,460	3,376,717	3,382,269	3,656,049	8.1%
Seward	64,983,550	63,339,389	67,919,337	63,924,561	84,936,104	71,225,960	-16.1%
Soldotna	135,844,788	142,094,422	149,486,225	159,239,797	153,639,412	170,095,199	10.7%
Other KPB	388,198,177	375,352,455	362,576,888	346,629,641	424,695,289	418,961,495	-1.4%
Total	828,193,306	824,423,525	838,560,786	838,534,882	982,799,753	975,707,556	-0.7%
Annual Change		-0.5%	1.7%	0.0%	17.2%	-0.7%	

Table 1.19

KPB YTD 6/30 GROSS Sales Ten Year Change by AREA - 1996-2006 - in \$				
			10 Year Change	
	1996	2006	Percentage	Numerical
Homer	93,700,385	142,411,646	52.0%	48,711,261
Kenai	103,279,511	169,357,207	64.0%	66,077,696
Seldovia	2,270,984	3,656,049	61.0%	1,385,065
Seward	58,011,462	71,225,960	22.8%	13,214,498
Soldotna	98,242,448	170,095,199	73.1%	71,852,751
Other KPB	283,382,196	418,961,495	47.8%	135,579,299
Total	638,886,986	975,707,556	52.7%	336,820,570

Table 1.20

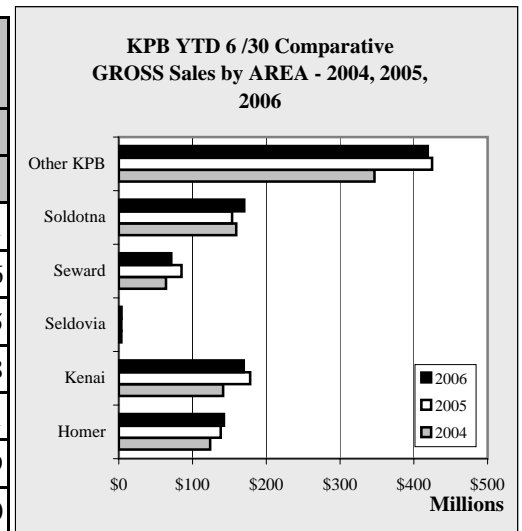

Chart 1.15

KPB YTD 6/30 GROSS Sales One Year Change by AREA - 2005-2006 - in \$				
			1 Year Change	
	2005	2006	Percentage	Numerical
Homer	138,107,534	142,411,646	3.1%	4,304,112
Kenai	178,039,145	169,357,207	-4.9%	-8,681,938
Seldovia	3,382,269	3,656,049	8.1%	273,780
Seward	84,936,104	71,225,960	-16.1%	-13,710,144
Soldotna	153,639,412	170,095,199	10.7%	16,455,787
Other KPB	424,695,289	418,961,495	-1.4%	-5,733,794
Total	982,799,753	975,707,556	-0.7%	-7,092,197

Table 1.21

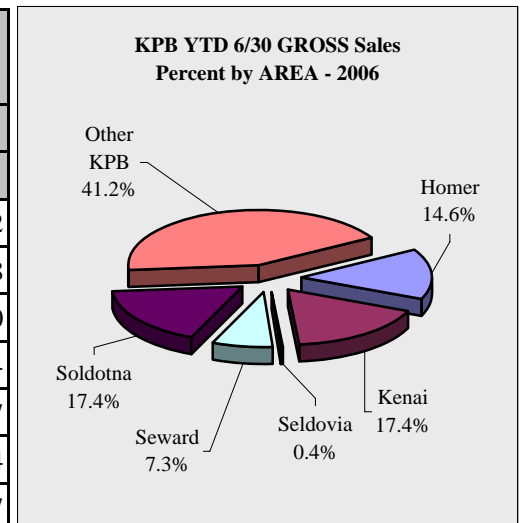

Chart 1.16

KPB Sales

KPB YTD 6/30 TAXABLE Sales by AREA - 2001-2006 - in \$							
	2001	2002	2003	2004	2005	2006	Annual Change
Homer	47,956,681	52,970,881	59,494,750	63,473,444	65,829,289	67,135,266	2.0%
Kenai	62,877,910	63,541,507	60,916,030	65,819,649	66,946,465	72,806,826	8.8%
Seldovia	1,539,588	1,472,454	1,561,936	1,506,315	1,505,158	1,579,311	4.9%
Seward	30,626,757	31,227,518	31,356,585	32,486,667	35,458,594	36,523,458	3.0%
Soldotna	75,406,451	77,241,566	81,491,289	86,397,085	90,905,994	97,326,488	7.1%
Other KPB	95,926,341	99,376,463	96,688,167	97,467,293	104,468,785	111,784,273	7.0%
Total	314,333,728	325,830,389	331,508,757	347,150,453	365,114,285	387,155,622	6.0%
Annual Change		3.7%	1.7%	4.7%	5.2%	6.0%	

Table 1.22

KPB YTD 6/30 TAXABLE Sales Ten Year Change by AREA - 1996-2006 - in \$				
			10 Year Change	
	1996	2006	Percentage	Numerical
Homer	41,051,877	67,135,266	63.5%	26,083,389
Kenai	53,647,406	72,806,826	35.7%	19,159,420
Seldovia	1,575,625	1,579,311	0.2%	3,686
Seward	24,437,608	36,523,458	49.5%	12,085,850
Soldotna	59,111,423	97,326,488	64.6%	38,215,065
Other KPB	75,771,714	111,784,273	47.5%	36,012,559
Total	255,595,653	387,155,622	51.5%	131,559,969

Table 1.23

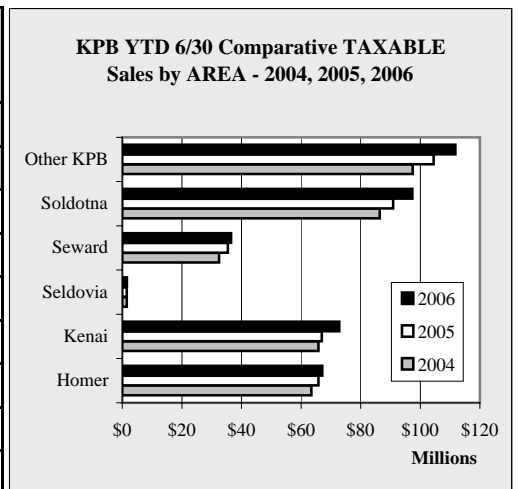

Chart 1.17

KPB YTD 6/30 TAXABLE Sales One Year Change by AREA - 2005-2006 - in \$				
			1 Year Change	
	2005	2006	Percentage	Numerical
Homer	65,829,289	67,135,266	2.0%	1,305,977
Kenai	66,946,465	72,806,826	8.8%	5,860,361
Seldovia	1,505,158	1,579,311	4.9%	74,153
Seward	35,458,594	36,523,458	3.0%	1,064,864
Soldotna	90,905,994	97,326,488	7.1%	6,420,494
Other KPB	104,468,785	111,784,273	7.0%	7,315,488
Total	365,114,285	387,155,622	6.0%	22,041,337

Table 1.24

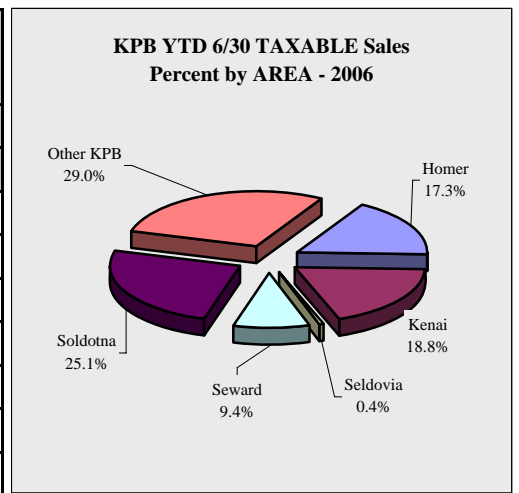

Chart 1.18

KPB Sales

KPB Annual GROSS Sales by INDUSTRY - 2000-2005 - in \$							
	2000	2001	2002	2003	2004	2005	Annual Change
Ag, Forest, Fish	24,816,872	17,584,763	16,750,059	22,009,310	27,631,235	33,688,173	21.9%
Mining	121,868,065	126,250,792	113,521,181	106,561,739	165,354,111	176,742,110	6.9%
Construction	185,994,582	241,706,588	229,371,225	258,251,958	237,336,814	287,397,573	21.1%
Manufacturing	117,856,947	287,725,053	201,051,098	199,442,339	264,943,324	307,865,301	16.2%
Trans, Comm, Pub Util	156,272,089	173,246,581	172,554,610	158,372,166	193,929,813	257,837,257	33.0%
Wholesale	171,235,874	177,036,125	188,223,387	194,212,922	366,603,918	362,992,085	-1.0%
Retail	580,370,933	633,597,773	625,002,974	644,637,228	699,850,661	734,600,440	5.0%
Finance, Ins, Real Estate	50,390,903	54,153,772	55,069,400	58,320,708	64,673,193	67,222,418	3.9%
Services	235,820,173	256,185,223	277,164,217	279,539,482	311,212,218	323,040,441	3.8%
Government	17,350	20,316	22,579	41,980	35,105	38,807	10.5%
Total	1,644,643,788	1,967,506,986	1,878,730,730	1,921,389,832	2,331,570,392	2,551,424,605	9.4%
Annual Change		19.6%	-4.5%	2.3%	21.3%	9.4%	

Table 1.25

KPB Annual GROSS Sales Ten Year Change by INDUSTRY - 1995-2005 - in \$				
			10 Year Change	
	1995	2005	Percentage	Numerical
Ag, Forest, Fish	80,977,261	33,688,173	-58.4%	-47,289,088
Mining	97,159,191	176,742,110	81.9%	79,582,919
Construction	170,655,843	287,397,573	68.4%	116,741,730
Manufacturing	167,949,814	307,865,301	83.3%	139,915,487
Trans, Comm, Pub Util	206,250,912	257,837,257	25.0%	51,586,345
Wholesale	124,049,520	362,992,085	192.6%	238,942,565
Retail	436,133,255	734,600,440	68.4%	298,467,185
Finance, Ins, Real Estate	46,762,294	67,222,418	43.8%	20,460,124
Services	176,459,662	323,040,441	83.1%	146,580,779
Government	10,041	38,807	286.5%	28,766
Total	1,506,407,793	2,551,424,605	69.4%	1,045,016,812

Table 1.26

KPB Annual GROSS Sales One Year Change by INDUSTRY - 2004-2005 - in \$				
			1 Year Change	
	2004	2005	Percentage	Numerical
Ag, Forest, Fish	27,631,235	33,688,173	21.9%	6,056,938
Mining	165,354,111	176,742,110	6.9%	11,387,999
Construction	237,336,814	287,397,573	21.1%	50,060,759
Manufacturing	264,943,324	307,865,301	16.2%	42,921,977
Trans, Comm, Pub Util	193,929,813	257,837,257	33.0%	63,907,444
Wholesale	366,603,918	362,992,085	-1.0%	-3,611,833
Retail	699,850,661	734,600,440	5.0%	34,749,779
Finance, Ins, Real Estate	64,673,193	67,222,418	3.9%	2,549,225
Services	311,212,218	323,040,441	3.8%	11,828,223
Government	35,105	38,807	10.5%	3,702
Total	2,331,570,392	2,551,424,605	9.4%	219,854,213

Table 1.27

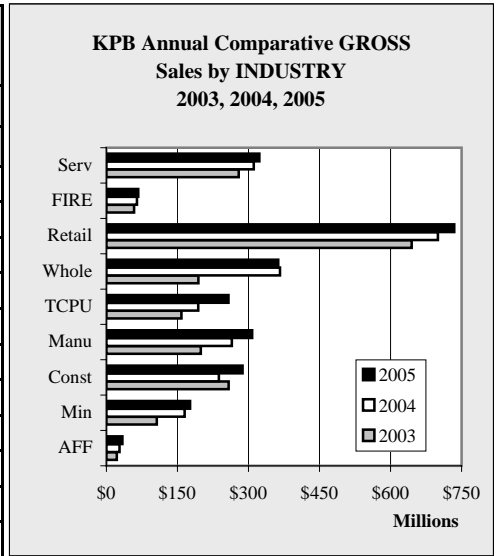

Chart 1.19

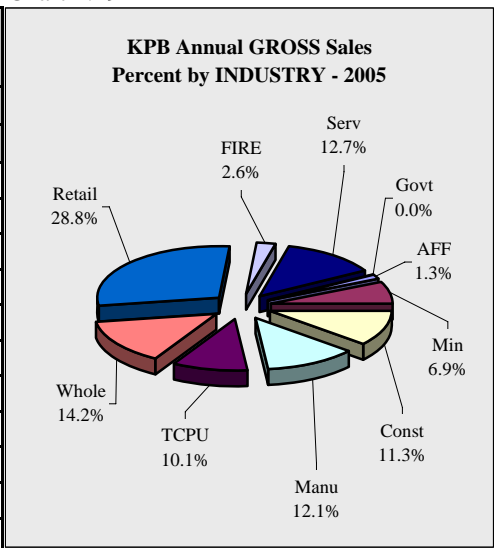

Chart 1.20

KPB Sales

KPB Annual TAXABLE Sales by INDUSTRY - 2000-2005 - in \$							
	2000	2001	2002	2003	2004	2005	Annual Change
Ag, Forest, Fish	4,148,862	4,391,790	4,461,252	5,010,961	5,525,243	6,003,178	8.7%
Mining	4,613,878	5,863,223	5,848,904	4,885,262	5,502,300	4,487,117	-18.5%
Construction	9,658,671	10,002,648	10,679,101	11,258,243	11,243,037	11,220,481	-0.2%
Manufacturing	9,792,611	9,654,663	9,620,274	9,239,486	9,859,946	9,731,407	-1.3%
Trans, Comm, Pub Util	77,420,153	79,415,747	83,947,088	81,373,510	82,713,089	91,686,098	10.8%
Wholesale	21,493,691	22,282,063	21,827,820	24,282,313	26,290,768	26,957,039	2.5%
Retail	383,777,809	411,721,005	419,542,948	429,206,254	461,643,675	490,159,639	6.2%
Finance, Ins, Real Estate	20,702,551	23,486,072	24,149,228	22,887,958	22,551,041	22,824,791	1.2%
Services	135,510,623	139,066,219	144,437,441	144,955,977	155,208,927	162,497,938	4.7%
Government	17,350	20,316	22,579	41,980	35,040	38,807	10.8%
Total	667,136,199	705,903,746	724,536,635	733,141,944	780,573,066	825,606,495	5.8%
Annual Change		5.8%	2.6%	1.2%	6.5%	5.8%	

Table 1.28

KPB Annual TAXABLE Sales Ten Year Change by INDUSTRY - 1995-2005 - in \$				
			10 Year Change	
	1995	2005	Percentage	Numerical
Ag, Forest, Fish	3,311,765	6,003,178	81.3%	2,691,413
Mining	4,406,014	4,487,117	1.8%	81,103
Construction	8,684,362	11,220,481	29.2%	2,536,119
Manufacturing	8,262,783	9,731,407	17.8%	1,468,624
Trans, Comm, Pub Util	65,018,675	91,686,098	41.0%	26,667,423
Wholesale	20,802,225	26,957,039	29.6%	6,154,814
Retail	315,230,896	490,159,639	55.5%	174,928,743
Finance, Ins, Real Estate	18,887,223	22,824,791	20.8%	3,937,568
Services	107,445,789	162,497,938	51.2%	55,052,149
Government	10,041	38,807	286.5%	28,766
Total	552,059,773	825,606,495	49.6%	273,546,722

Table 1.29

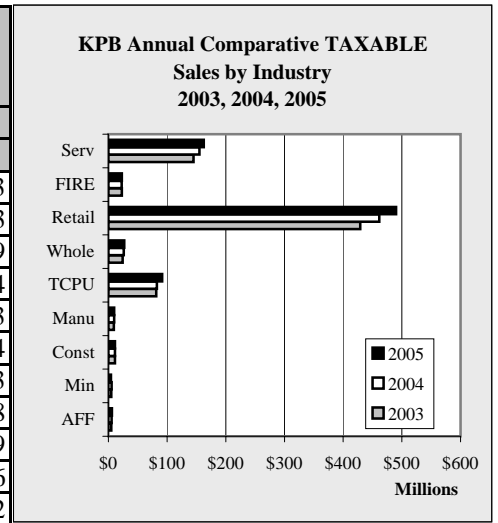

Chart 1.21

KPB Annual TAXABLE Sales One Year Change by INDUSTRY - 2004-2005 - in \$				
			1 Year Change	
	2004	2005	Percentage	Numerical
Ag, Forest, Fish	5,525,243	6,003,178	8.7%	477,935
Mining	5,502,300	4,487,117	-18.5%	-1,015,183
Construction	11,243,037	11,220,481	-0.2%	-22,556
Manufacturing	9,859,946	9,731,407	-1.3%	-128,539
Trans, Comm, Pub Util	82,713,089	91,686,098	10.8%	8,973,009
Wholesale	26,290,768	26,957,039	2.5%	666,271
Retail	461,643,675	490,159,639	6.2%	28,515,964
Finance, Ins, Real Estate	22,551,041	22,824,791	1.2%	273,750
Services	155,208,927	162,497,938	4.7%	7,289,011
Government	35,040	38,807	10.8%	3,767
Total	780,573,066	825,606,495	5.8%	45,033,429

Table 1.30

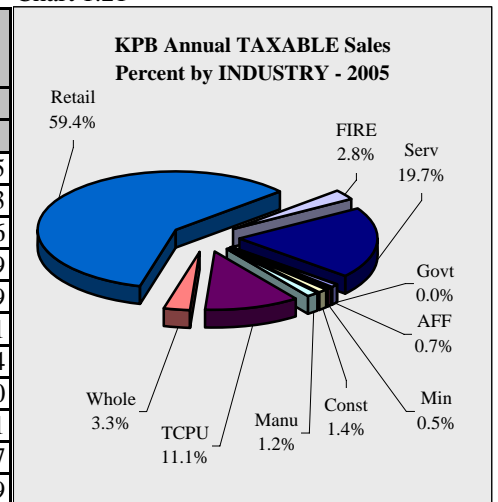

Chart 1.22

KPB Sales

KPB Annual GROSS Sales by AREA - 2000-2005 - in \$							
	2000	2001	2002	2003	2004	2005	Annual Change
Homer	215,981,724	229,703,507	263,240,684	274,071,969	290,446,016	310,198,044	6.8%
Kenai	283,682,464	310,426,425	279,752,403	283,414,662	406,578,389	464,709,325	14.3%
Seldovia	5,267,325	5,249,471	4,817,877	7,259,554	8,329,831	6,869,692	-17.5%
Seward	142,152,279	148,360,553	142,369,626	156,961,936	166,196,695	189,280,313	13.9%
Soldotna	289,255,311	309,118,231	325,900,620	337,909,657	361,256,259	383,967,628	6.3%
KPB Other	708,304,685	964,648,799	862,649,520	861,772,054	1,098,763,202	1,196,399,603	8.9%
Total	1,644,643,788	1,967,506,986	1,878,730,730	1,921,389,832	2,331,570,392	2,551,424,605	9.4%
Annual Change		19.6%	-4.5%	2.3%	21.3%	9.4%	

Table 1.31

KPB Annual GROSS Sales Ten Year Change by AREA - 1995-2005 - in \$				
			10 Year Change	
	1995	2005	Percentage	Numerical
Homer	197,603,895	310,198,044	57.0%	112,594,149
Kenai	268,097,707	464,709,325	73.3%	196,611,618
Seldovia	5,837,861	6,869,692	17.7%	1,031,831
Seward	127,468,033	189,280,313	48.5%	61,812,280
Soldotna	212,793,589	383,967,628	80.4%	171,174,039
KPB Other	694,606,708	1,196,399,603	72.2%	501,792,895
Total	1,506,407,793	2,551,424,605	69.4%	1,045,016,812

Table 1.32

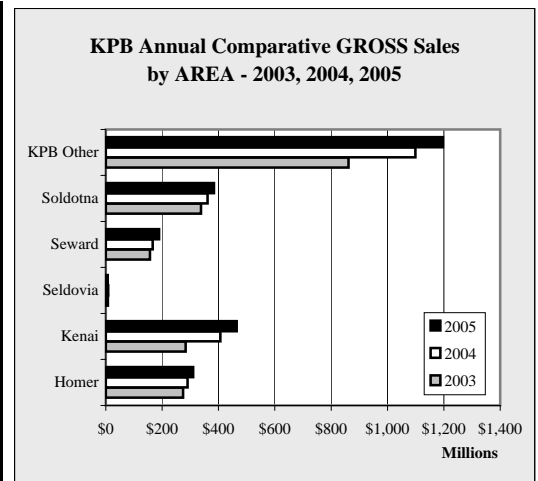

Chart 1.23

KPB Annual GROSS Sales One Year Change by AREA - 2004-2005 - in \$				
			1 Year Change	
	2004	2005	Percentage	Numerical
Homer	290,446,016	310,198,044	6.8%	19,752,028
Kenai	406,578,389	464,709,325	14.3%	58,130,936
Seldovia	8,329,831	6,869,692	-17.5%	-1,460,139
Seward	166,196,695	189,280,313	13.9%	23,083,618
Soldotna	361,256,259	383,967,628	6.3%	22,711,369
KPB Other	1,098,763,202	1,196,399,603	8.9%	97,636,401
Total	2,331,570,392	2,551,424,605	9.4%	219,854,213

Table 1.33

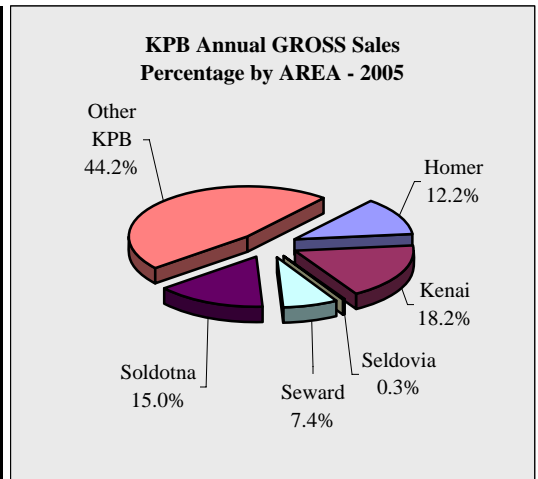

Chart 1.24

KPB Sales

KPB Annual TAXABLE Sales by AREA - 2000-2005 - in \$							
	2000	2001	2002	2003	2004	2005	Annual Change
Homer	103,190,116	107,311,539	121,292,548	131,727,383	139,993,361	145,704,361	4.1%
Kenai	127,766,126	137,043,924	136,685,248	121,354,719	138,680,604	144,303,693	4.1%
Seldovia	3,418,123	3,359,279	3,272,389	3,376,944	3,386,312	3,380,596	-0.2%
Seward	73,983,426	74,225,591	75,590,722	76,348,733	79,946,961	88,003,759	10.1%
Soldotna	159,436,128	172,418,438	176,979,392	190,628,900	200,056,928	211,333,890	5.6%
KPB Other	199,342,280	211,544,975	210,716,336	209,705,265	218,508,900	232,880,196	6.6%
Total	667,136,199	705,903,746	724,536,635	733,141,944	780,573,066	825,606,495	5.8%
Annual Change		5.8%	2.6%	1.2%	6.5%	5.8%	

Table 1.34

KPB Annual TAXABLE Sales Ten Year Change by AREA - 1995-2005 - in \$				
			10 Year Change	
	1995	2005	Percentage	Numerical
Homer	88,195,392	145,704,361	65.2%	57,508,969
Kenai	112,591,635	144,303,693	28.2%	31,712,058
Seldovia	3,576,948	3,380,596	-5.5%	-196,352
Seward	55,756,987	88,003,759	57.8%	32,246,772
Soldotna	129,069,096	211,333,890	63.7%	82,264,794
KPB Other	162,869,715	232,880,196	43.0%	70,010,481
Total	552,059,773	825,606,495	49.6%	273,546,722

Table 1.35

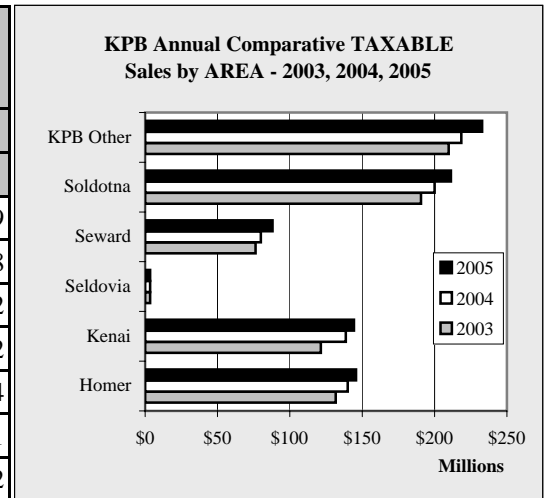

Chart 1.25

KPB Annual TAXABLE Sales One Year Change by AREA - 2004-2005 - in \$				
			1 Year Change	
	2004	2005	Percentage	Numerical
Homer	139,993,361	145,704,361	4.1%	5,711,000
Kenai	138,680,604	144,303,693	4.1%	5,623,089
Seldovia	3,386,312	3,380,596	-0.2%	-5,716
Seward	79,946,961	88,003,759	10.1%	8,056,798
Soldotna	200,056,928	211,333,890	5.6%	11,276,962
KPB Other	218,508,900	232,880,196	6.6%	14,371,296
Total	780,573,066	825,606,495	5.8%	45,033,429

Table 1.36

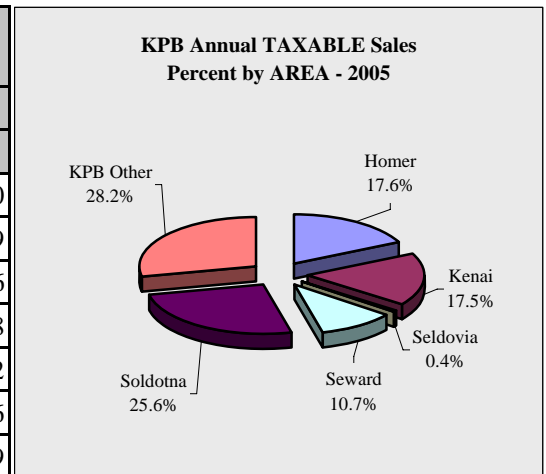

Chart 1.26

KPB Sales

KPB Annual GROSS Sales by INDUSTRY by Quarter - 2003-2006 - in \$					
	1st Quarter	2nd Quarter	3rd Quarter	4th Quarter	Total
2003					
Agriculture, Forestry, Fishing	2,019,939	4,045,723	13,491,140	2,452,508	22,009,310
Mining	19,260,142	25,083,685	30,366,980	31,850,932	106,561,739
Construction	43,286,848	67,679,718	81,917,870	65,367,522	258,251,958
Manufacturing	38,576,448	34,259,747	66,216,357	60,389,787	199,442,339
Transportation, Communication, Public Utilities	38,217,073	38,841,966	43,819,198	37,493,929	158,372,166
Wholesale	35,918,425	50,841,751	60,869,241	46,583,505	194,212,922
Retail	123,115,445	170,701,632	201,806,657	149,013,494	644,637,228
Finance, Insurance, Real Estate	11,797,457	15,377,000	16,119,572	15,026,679	58,320,708
Services	41,584,487	77,932,301	108,566,982	51,455,712	279,539,482
Government	12,319	8,680	12,192	8,789	41,980
Total	353,788,583	484,772,203	623,186,189	459,642,857	1,921,389,832
2004					
Agriculture, Forestry, Fishing	2,340,926	3,911,032	15,695,017	5,684,260	27,631,235
Mining	39,801,394	32,098,347	39,000,757	54,453,613	165,354,111
Construction	28,598,260	42,316,016	67,053,184	99,369,354	237,336,814
Manufacturing	26,107,055	15,540,229	97,207,179	126,088,861	264,943,324
Transportation, Communication, Public Utilities	38,968,563	48,292,512	55,432,460	51,236,278	193,929,813
Wholesale	41,782,771	50,630,515	55,365,704	218,824,928	366,603,918
Retail	126,806,114	187,668,631	224,501,848	160,874,068	699,850,661
Finance, Insurance, Real Estate	13,390,042	14,525,303	17,051,661	19,706,187	64,673,193
Services	43,096,322	82,638,666	120,102,838	65,374,392	311,212,218
Government	13,663	8,521	9,184	3,737	35,105
Total	360,905,110	477,629,772	691,419,832	801,615,678	2,331,570,392
2005					
Agriculture, Forestry, Fishing	2,976,106	5,742,115	18,289,095	6,680,857	33,688,173
Mining	39,831,609	35,586,431	45,974,895	55,349,175	176,742,110
Construction	42,449,437	69,893,319	76,454,992	98,599,825	287,397,573
Manufacturing	34,020,432	59,287,458	102,449,558	112,107,853	307,865,301
Transportation, Communication, Public Utilities	58,387,141	68,723,636	55,849,784	74,876,696	257,837,257
Wholesale	37,234,787	36,413,842	43,393,077	245,950,379	362,992,085
Retail	131,219,480	200,150,931	238,302,332	164,927,697	734,600,440
Finance, Insurance, Real Estate	11,946,986	16,585,118	18,624,332	20,065,982	67,222,418
Services	46,145,413	86,181,796	127,114,780	63,598,452	323,040,441
Government	15,214	8,502	11,907	3,184	38,807
Total	404,226,605	578,573,148	726,464,752	842,160,100	2,551,424,605
2006					
					Year to Date
Agriculture, Forestry, Fishing	2,194,367	6,278,383			8,472,750
Mining	44,690,630	48,554,473			93,245,103
Construction	34,941,519	58,729,783			93,671,302
Manufacturing	21,257,569	50,496,849			71,754,418
Transportation, Communication, Public Utilities	52,004,607	72,004,359			124,008,966
Wholesale	26,148,106	36,103,657			62,251,763
Retail	142,037,881	212,705,411			354,743,292
Finance, Insurance, Real Estate	14,338,165	16,125,497			30,463,662
Services	47,389,948	89,681,853			137,071,801
Government	11,248	13,251			24,499
Total	385,014,040	590,693,516	0	0	975,707,556

Table 1.37

KPB Sales

KPB Annual TAXABLE Sales by INDUSTRY by Quarter - 2003-2006 - in \$					
	1st Quarter	2nd Quarter	3rd Quarter	4th Quarter	Total
2003					
Agriculture, Forestry, Fishing	763,045	1,577,278	1,697,754	972,884	5,010,961
Mining	1,233,618	1,170,493	1,313,871	1,167,280	4,885,262
Construction	2,051,978	3,126,868	3,316,609	2,762,788	11,258,243
Manufacturing	1,438,887	2,607,213	3,333,206	1,860,180	9,239,486
Transportation, Communication, Public Utilities	21,650,525	20,321,138	19,718,329	19,683,518	81,373,510
Wholesale	5,052,561	6,337,983	7,103,240	5,788,529	24,282,313
Retail	79,978,199	112,406,985	139,052,180	97,768,890	429,206,254
Finance, Insurance, Real Estate	5,334,447	5,999,648	6,488,579	5,065,284	22,887,958
Services	18,779,648	41,657,244	62,851,352	21,667,733	144,955,977
Government	12,319	8,680	12,192	8,789	41,980
Total	136,295,227	195,213,530	244,887,312	156,745,875	733,141,944
2004					
Agriculture, Forestry, Fishing	889,277	1,674,503	1,979,566	981,897	5,525,243
Mining	1,047,668	1,082,504	1,908,215	1,463,913	5,502,300
Construction	2,209,429	2,917,698	3,278,174	2,837,736	11,243,037
Manufacturing	1,512,130	2,737,701	3,843,780	1,766,335	9,859,946
Transportation, Communication, Public Utilities	21,023,055	19,475,240	21,221,357	20,993,437	82,713,089
Wholesale	5,892,430	6,600,388	7,644,161	6,153,789	26,290,768
Retail	83,126,196	122,332,545	153,388,513	102,796,421	461,643,675
Finance, Insurance, Real Estate	4,940,501	5,773,373	6,667,901	5,169,266	22,551,041
Services	19,252,256	44,641,440	69,201,297	22,113,934	155,208,927
Government	13,598	8,521	9,184	3,737	35,040
Total	139,906,540	207,243,913	269,142,148	164,280,465	780,573,066
2005					
Agriculture, Forestry, Fishing	949,166	1,737,267	2,204,017	1,112,728	6,003,178
Mining	1,087,830	1,030,074	1,085,999	1,283,214	4,487,117
Construction	2,110,171	3,144,464	3,235,011	2,730,835	11,220,481
Manufacturing	1,344,403	2,733,200	3,788,930	1,864,874	9,731,407
Transportation, Communication, Public Utilities	23,078,176	22,116,281	23,049,988	23,441,653	91,686,098
Wholesale	5,623,554	6,698,143	8,065,336	6,570,006	26,957,039
Retail	85,830,493	130,554,777	164,143,249	109,631,120	490,159,639
Finance, Insurance, Real Estate	4,727,622	5,794,702	6,838,374	5,464,093	22,824,791
Services	19,623,317	46,906,929	73,382,745	22,584,947	162,497,938
Government	15,214	8,502	11,907	3,184	38,807
Total	144,389,946	220,724,339	285,805,556	174,686,654	825,606,495
2006					
					Year to Date
Agriculture, Forestry, Fishing	1,053,148	1,799,707			2,852,855
Mining	1,027,493	1,161,365			2,188,858
Construction	2,095,241	2,835,875			4,931,116
Manufacturing	1,382,903	2,601,637			3,984,540
Transportation, Communication, Public Utilities	26,527,472	23,850,568			50,378,040
Wholesale	6,399,572	7,304,943			13,704,515
Retail	92,526,803	137,398,293			229,925,096
Finance, Insurance, Real Estate	5,029,262	5,857,751			10,887,013
Services	20,754,535	47,524,555			68,279,090
Government	11,248	13,251			24,499
Total	156,807,677	230,347,945	0	0	387,155,622

Table 1.38

KPB Sales

KPB Annual GROSS Sales by AREA by Quarter - 2001-2006 - in \$					
	1st Qtr	2nd Qtr	3rd Qtr	4th Qtr	Total
2001					
Homer	40,844,978	56,857,475	77,453,956	54,547,098	229,703,507
Kenai	62,418,286	76,673,936	94,911,501	76,422,702	310,426,425
Seldovia	898,811	1,473,305	1,957,554	919,801	5,249,471
Seward	20,531,272	44,452,278	62,873,649	20,503,354	148,360,553
Soldotna	60,802,277	75,042,511	95,670,432	77,603,011	309,118,231
Other KPB	170,550,210	217,647,967	286,388,798	290,061,824	964,648,799
Total	356,045,834	472,147,472	619,255,890	520,057,790	1,967,506,986
2002					
Homer	44,269,653	68,675,179	89,708,860	60,586,992	263,240,684
Kenai	60,596,369	67,929,291	82,601,639	68,625,104	279,752,403
Seldovia	1,011,712	1,155,055	1,694,174	956,936	4,817,877
Seward	22,954,013	40,385,376	56,721,649	22,308,588	142,369,626
Soldotna	62,331,750	79,762,672	103,625,416	80,180,782	325,900,620
Other KPB	159,438,133	215,914,322	262,753,549	224,543,516	862,649,520
Total	350,601,630	473,821,895	597,105,287	457,201,918	1,878,730,730
2003					
Homer	51,228,276	75,287,944	87,226,845	60,328,904	274,071,969
Kenai	62,150,857	67,434,799	81,240,276	72,588,730	283,414,662
Seldovia	847,005	1,629,455	2,833,785	1,949,309	7,259,554
Seward	20,935,184	46,984,153	61,708,185	27,334,414	156,961,936
Soldotna	64,257,981	85,228,244	106,268,314	82,155,118	337,909,657
Other KPB	154,369,280	208,207,608	283,908,784	215,286,382	861,772,054
Total	353,788,583	484,772,203	623,186,189	459,642,857	1,921,389,832
2004					
Homer	48,141,586	75,752,214	93,935,395	72,616,821	290,446,016
Kenai	61,083,004	80,387,362	97,860,036	167,247,987	406,578,389
Seldovia	1,405,047	1,971,670	1,809,067	3,144,047	8,329,831
Seward	21,175,289	42,749,272	63,911,158	38,360,976	166,196,695
Soldotna	69,929,668	89,310,129	107,195,699	94,820,763	361,256,259
Other KPB	159,170,516	187,459,125	326,708,477	425,425,084	1,098,763,202
Total	360,905,110	477,629,772	691,419,832	801,615,678	2,331,570,392
2005					
Homer	51,904,345	86,203,189	101,494,973	70,595,537	310,198,044
Kenai	75,571,200	102,467,945	112,299,497	174,370,683	464,709,325
Seldovia	1,261,735	2,120,534	2,274,951	1,212,472	6,869,692
Seward	26,468,833	58,467,271	70,152,815	34,191,394	189,280,313
Soldotna	65,975,642	87,663,770	113,981,016	116,347,200	383,967,628
Other KPB	183,044,850	241,650,439	326,261,500	445,442,814	1,196,399,603
Total	404,226,605	578,573,148	726,464,752	842,160,100	2,551,424,605
2006					
					Year to Date
Homer	56,197,995	86,213,651			142,411,646
Kenai	63,014,910	106,342,297			169,357,207
Seldovia	1,516,238	2,139,811			3,656,049
Seward	21,640,529	49,585,431			71,225,960
Soldotna	72,462,057	97,633,142			170,095,199
Other KPB	170,182,311	248,779,184			418,961,495
Total	385,014,040	590,693,516	0	0	975,707,556

Table 1.39

KPB Sales

KPB Annual TAXABLE Sales by AREA by Quarter - 2001-2006 - in \$					
	1st Qtr	2nd Qtr	3rd Qtr	4th Qtr	Total
2001					
Homer	17,765,204	30,191,477	37,574,702	21,780,156	107,311,539
Kenai	27,889,241	34,988,669	38,162,815	36,003,199	137,043,924
Seldovia	583,555	956,033	1,207,525	612,166	3,359,279
Seward	9,073,493	21,553,264	33,591,333	10,007,501	74,225,591
Soldotna	32,492,377	42,914,074	54,143,248	42,868,739	172,418,438
Other KPB	38,055,259	57,871,082	68,857,364	46,761,270	211,544,975
Total	125,859,129	188,474,599	233,536,987	158,033,031	705,903,746
2002					
Homer	18,699,958	34,270,923	43,258,197	25,063,470	121,292,548
Kenai	28,916,700	34,624,807	38,168,856	34,974,885	136,685,248
Seldovia	573,624	898,830	1,191,989	607,946	3,272,389
Seward	9,051,044	22,176,474	34,338,060	10,025,144	75,590,722
Soldotna	33,736,608	43,504,958	57,489,123	42,248,703	176,979,392
Other KPB	41,860,984	57,515,479	69,091,566	42,248,307	210,716,336
Total	132,838,918	192,991,471	243,537,791	155,168,455	724,536,635
2003					
Homer	22,456,282	37,038,468	45,127,086	27,105,547	131,727,383
Kenai	31,103,976	29,812,054	31,362,238	29,076,451	121,354,719
Seldovia	598,970	962,966	1,140,319	674,689	3,376,944
Seward	9,284,504	22,072,081	34,702,846	10,289,302	76,348,733
Soldotna	34,464,622	47,026,667	62,579,271	46,558,340	190,628,900
Other KPB	38,386,873	58,301,294	69,975,552	43,041,546	209,705,265
Total	136,295,227	195,213,530	244,887,312	156,745,875	733,141,944
2004					
Homer	23,824,920	39,648,524	49,027,379	27,492,538	139,993,361
Kenai	29,556,491	36,263,158	40,042,566	32,818,389	138,680,604
Seldovia	566,726	939,589	1,182,138	697,859	3,386,312
Seward	9,494,764	22,991,903	37,073,868	10,386,426	79,946,961
Soldotna	37,385,342	49,011,743	66,180,549	47,479,294	200,056,928
Other KPB	39,078,297	58,388,996	75,635,648	45,405,959	218,508,900
Total	139,906,540	207,243,913	269,142,148	164,280,465	780,573,066
2005					
Homer	24,335,943	41,493,346	51,190,632	28,684,440	145,704,361
Kenai	29,520,027	37,426,438	42,586,893	34,770,335	144,303,693
Seldovia	573,017	932,141	1,215,292	660,146	3,380,596
Seward	10,090,985	25,367,609	41,121,629	11,423,536	88,003,759
Soldotna	38,734,169	52,171,825	69,999,483	50,428,413	211,333,890
Other KPB	41,135,805	63,332,980	79,691,627	48,719,784	232,880,196
Total	144,389,946	220,724,339	285,805,556	174,686,654	825,606,495
2006					
					Year to Date
Homer	25,841,653	41,293,613			67,135,266
Kenai	32,115,030	40,691,796			72,806,826
Seldovia	635,812	943,499			1,579,311
Seward	10,161,964	26,361,494			36,523,458
Soldotna	42,166,078	55,160,410			97,326,488
Other KPB	45,887,140	65,897,133			111,784,273
Total	156,807,677	230,347,945	0	0	387,155,622

Table 1.40

KPB Construction

KPB 2nd Quarter Permit VALUES by AREA - 2001-2006 - in \$							
	2001	2002	2003	2004	2005	2006	Annual Change
Homer	4,102,040	2,528,209	7,929,500	7,433,711	11,246,000	7,467,100	-33.6%
Kenai	7,597,900	4,569,400	2,728,350	1,897,400	2,557,300	4,157,100	62.6%
Seldovia	25,000	8,000	0	156,200	466,000	87,000	-81.3%
Seward	666,239	3,888,887	3,672,010	7,443,900	758,540	2,184,672	188.0%
Soldotna	3,231,190	7,003,458	4,233,924	3,748,573	6,832,235	7,231,328	5.8%
Total	15,622,369	17,997,954	18,563,784	20,679,784	21,860,075	21,127,200	-3.4%
Annual Change		15.2%	3.1%	11.4%	5.7%	-3.4%	

Table 1.41

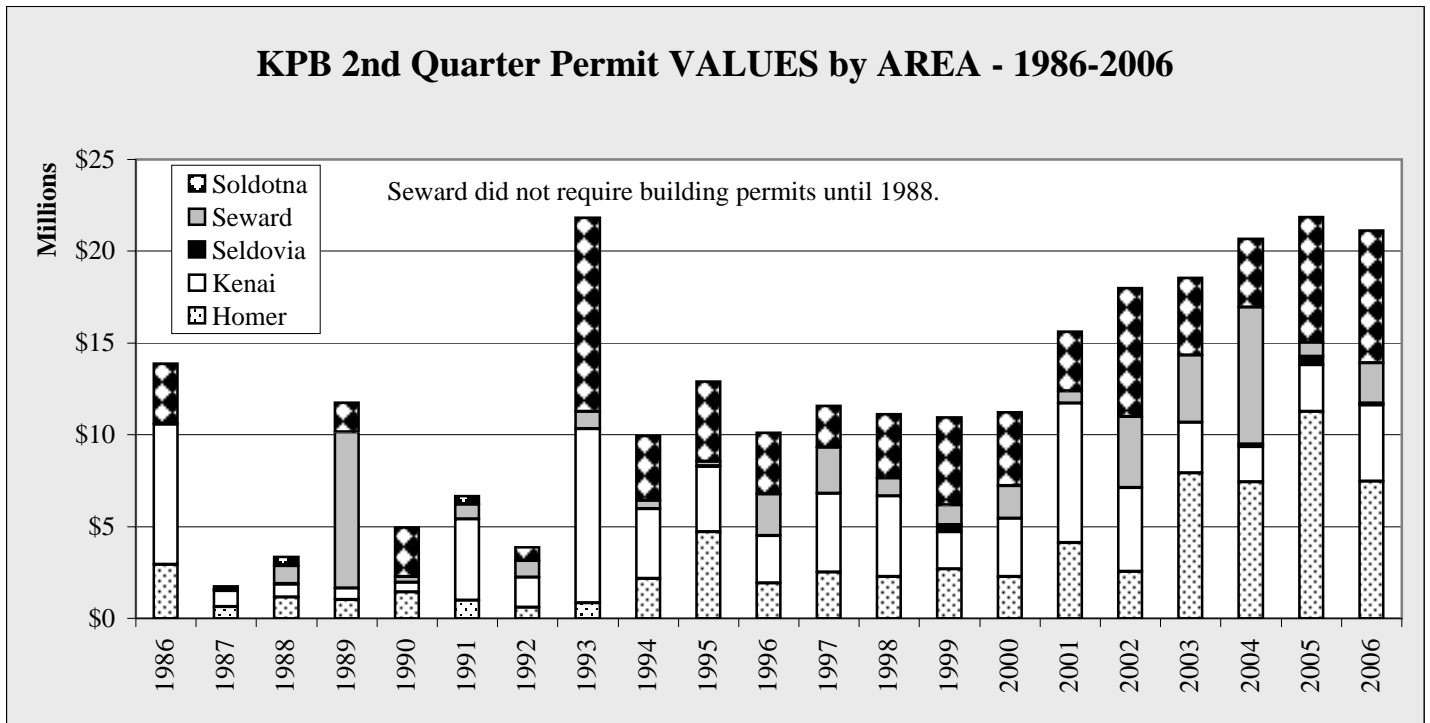

Chart 1.27

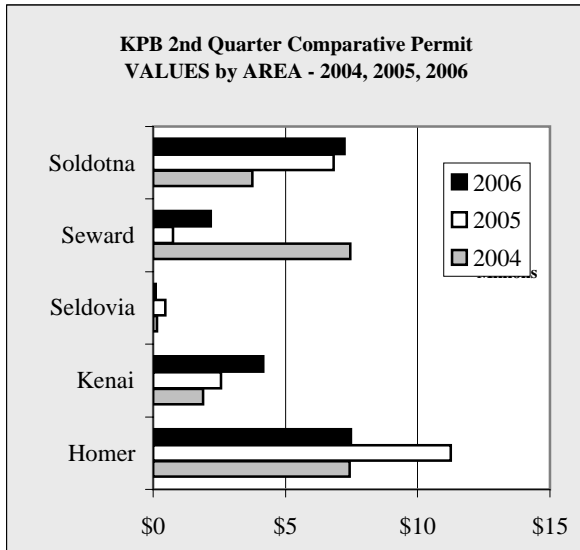

Chart 1.28

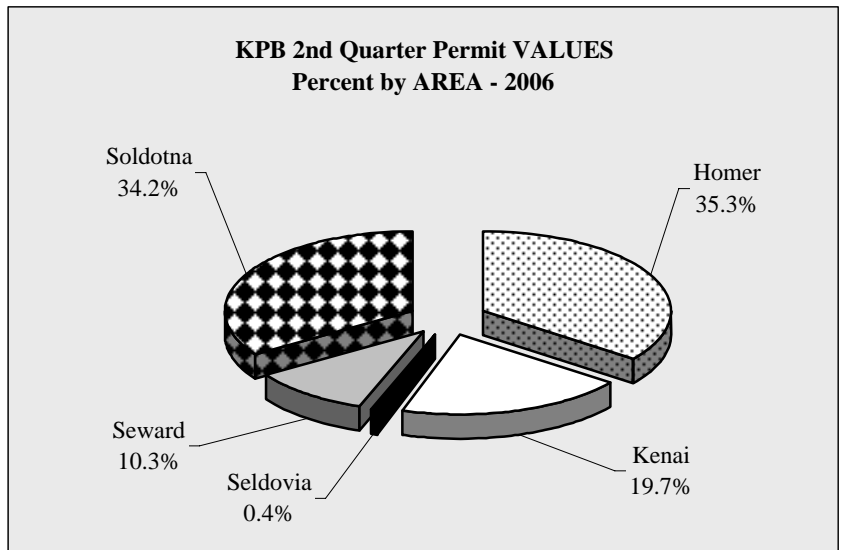

Chart 1.29

KPB Construction

KPB 2nd Quarter Permit VOLUME by AREA - 2001-2006

	2001	2002	2003	2004	2005	2006	Annual Change
Homer	34	17	34	26	47	39	-17.0%
Kenai	42	37	40	30	33	42	27.3%
Seldovia	1	2	0	3	6	6	0.0%
Seward	14	29	13	21	19	23	21.1%
Soldotna	37	51	36	26	40	25	-37.5%
Total	128	136	123	106	145	135	-6.9%
Annual Change		6.3%	-9.6%	-13.8%	36.8%	-6.9%	

Table 1.42

KPB 2nd Quarter Permit VOLUME by AREA - 1986-2006

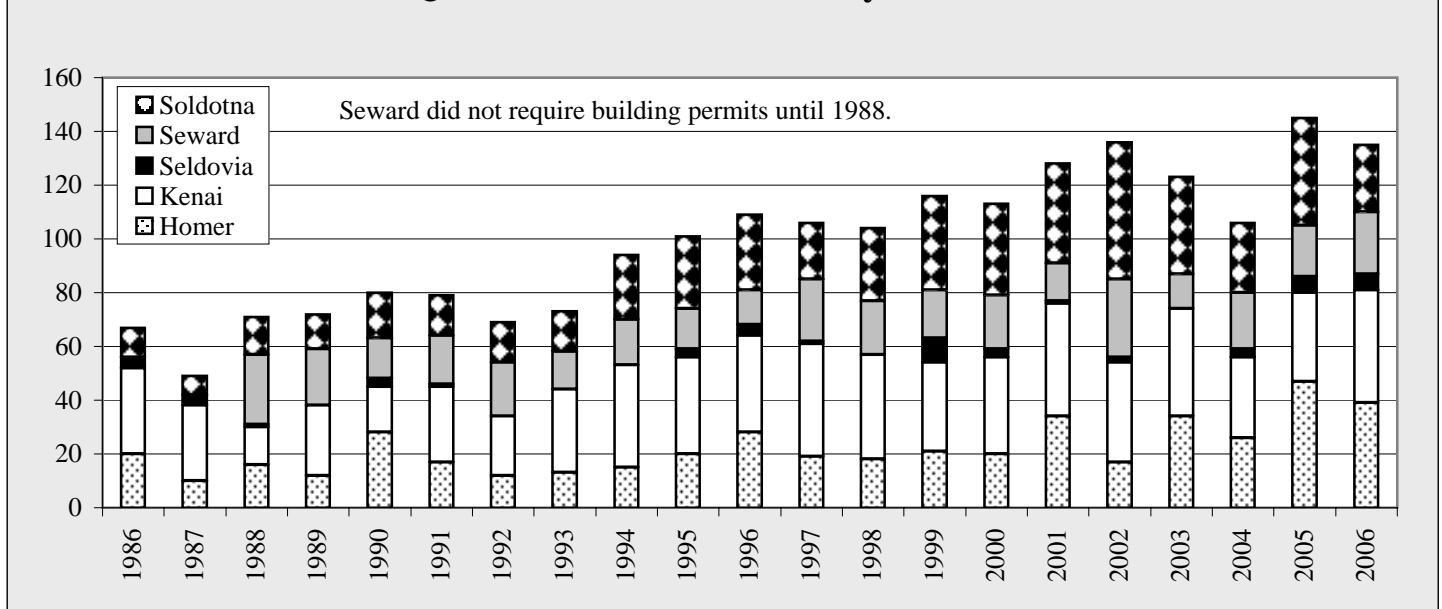

Chart 1.30

KPB 2nd Quarter Comparative VOLUME by AREA - 2004, 2005, 2006

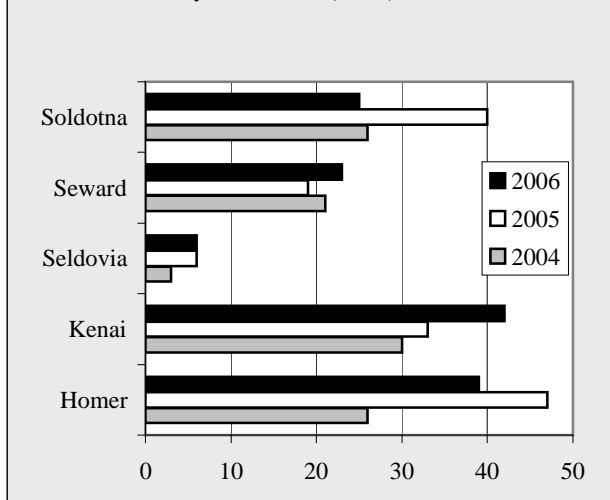

Chart 1.31

KPB 2nd Quarter Permit VOLUME Percent by AREA - 2006

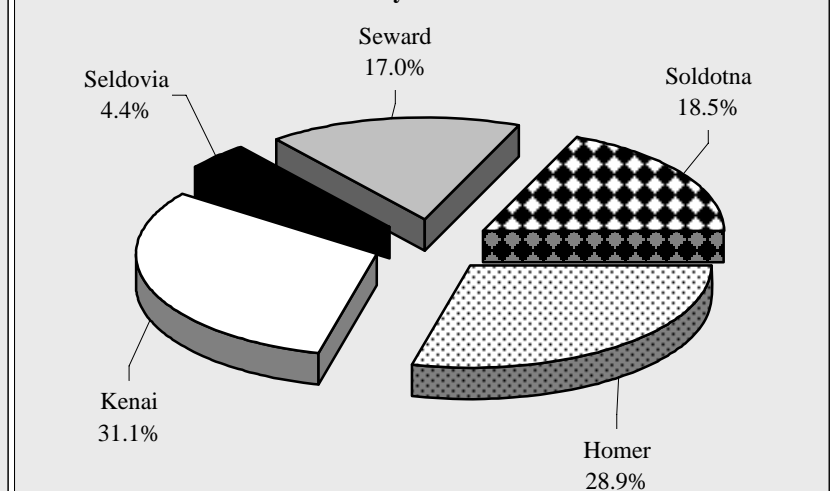

Chart 1.32

KPB Construction

KPB 2nd Quarter Permit VALUES by TYPE - 2001-2006 - in \$							
	2001	2002	2003	2004	2005	2006	Annual Change
New Residential	7,367,801	6,145,753	7,868,834	6,374,487	7,560,499	10,219,599	35.2%
Residential Alter/Add	758,779	1,044,943	984,340	483,839	812,470	830,630	2.2%
New Commercial	5,384,800	8,376,305	8,965,210	11,147,815	11,897,148	8,135,648	-31.6%
Commercial Alter/Add	2,110,989	2,430,953	745,400	2,673,643	1,589,958	1,941,323	22.1%
Total	15,622,369	17,997,954	18,563,784	20,679,784	21,860,075	21,127,200	-3.4%
Annual Change		15.2%	3.1%	11.4%	5.7%	-3.4%	

Table 1.43

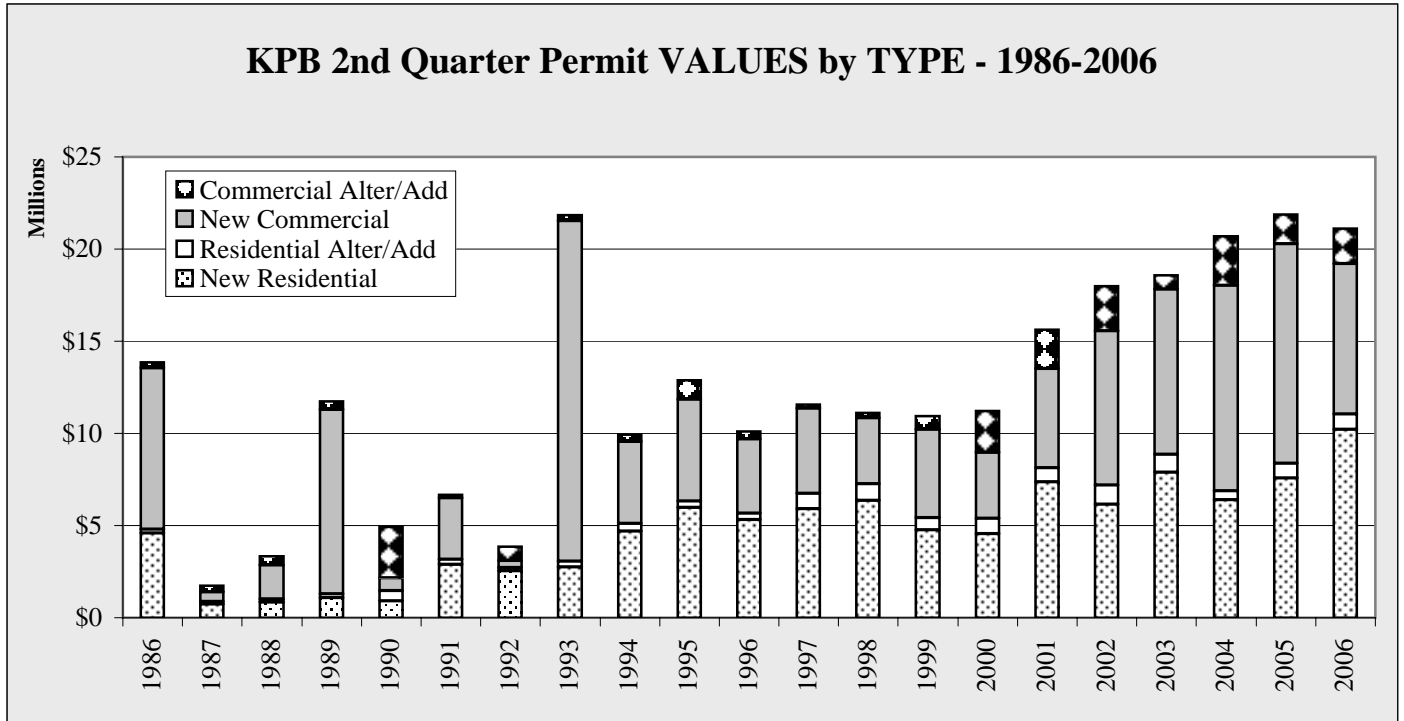

Chart 1.33

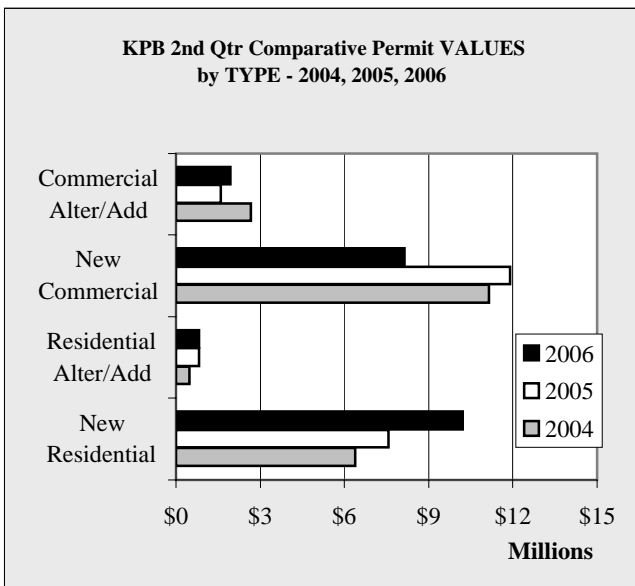

Chart 1.34

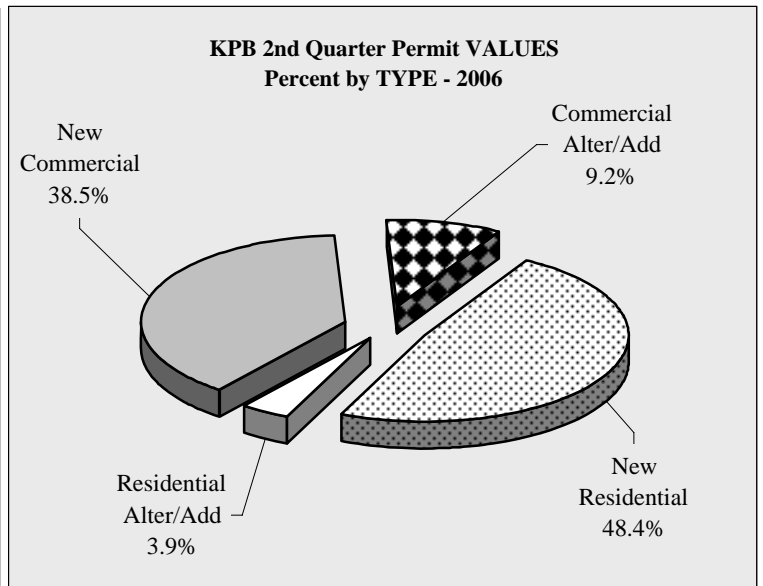

Chart 1.35

KPB Construction

KPB 2nd Quarter Permit VOLUME by TYPE - 2001-2006

	2001	2002	2003	2004	2005	2006	Annual Change
New Residential	45	45	47	34	49	57	16.3%
Residential Alter/Add	38	42	33	30	46	40	-13.0%
New Commercial	9	17	17	11	27	22	-18.5%
Commercial Alter/Add	36	32	26	31	23	16	-30.4%
Total	128	136	123	106	145	135	-6.9%
Annual Change		6.3%	-9.6%	-13.8%	36.8%	-6.9%	

Table 1.44

KPB 2nd Quarter Permit VOLUME by TYPE - 1986-2006

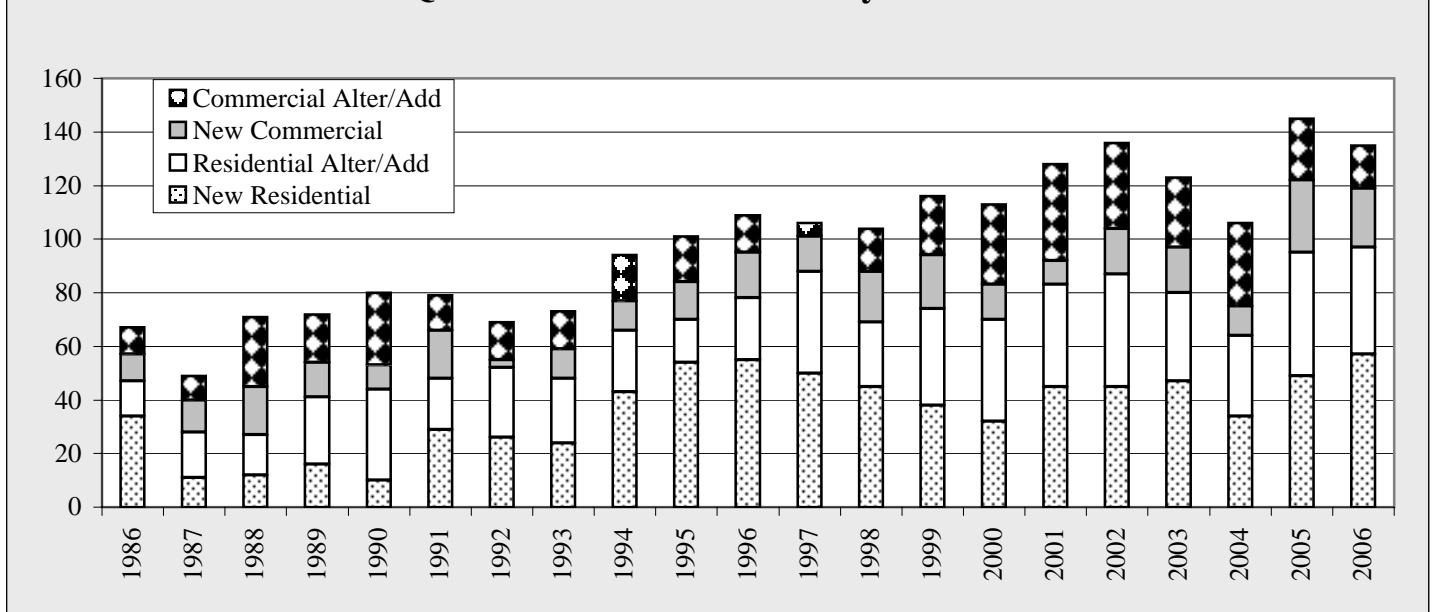

Chart 1.36

**KPB 2nd Qtr Comparative VOLUME by TYPE
2004 2005, 2006**

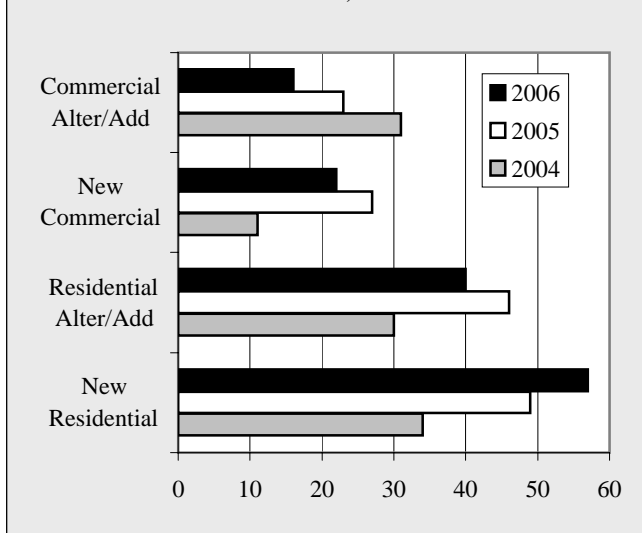

Chart 1.37

**KPB 2nd Quarter Permit VOLUME
Percent by TYPE - 2006**

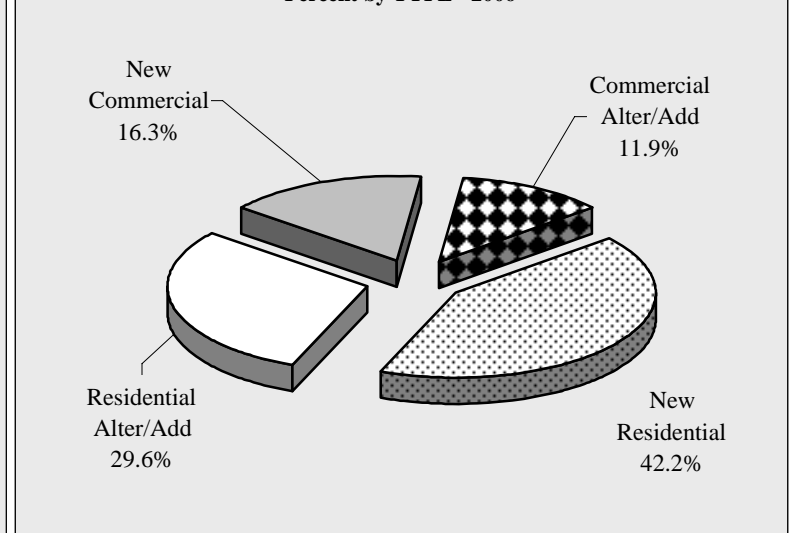

Chart 1.38

KPB Construction

KPB YTD 6/30 Permit VALUES by AREA - 2001-2006 - in \$							
	2001	2002	2003	2004	2005	2006	Annual Change
Homer	4,792,040	3,456,929	9,263,840	11,147,731	14,351,900	10,738,100	-25.2%
Kenai	8,417,400	8,457,600	4,285,950	2,209,400	2,982,800	4,920,600	65.0%
Seldovia	35,000	18,000	31,000	176,200	481,000	117,000	-75.7%
Seward	1,082,939	4,370,327	5,577,365	15,185,500	1,930,840	2,806,889	45.4%
Soldotna	6,282,408	8,209,048	4,660,942	8,812,896	8,253,790	9,347,769	13.3%
Total	20,609,787	24,511,904	23,819,097	37,531,727	28,000,330	27,930,358	-0.2%
Annual Change		18.9%	-2.8%	57.6%	-25.4%	-0.2%	

Table 1.45

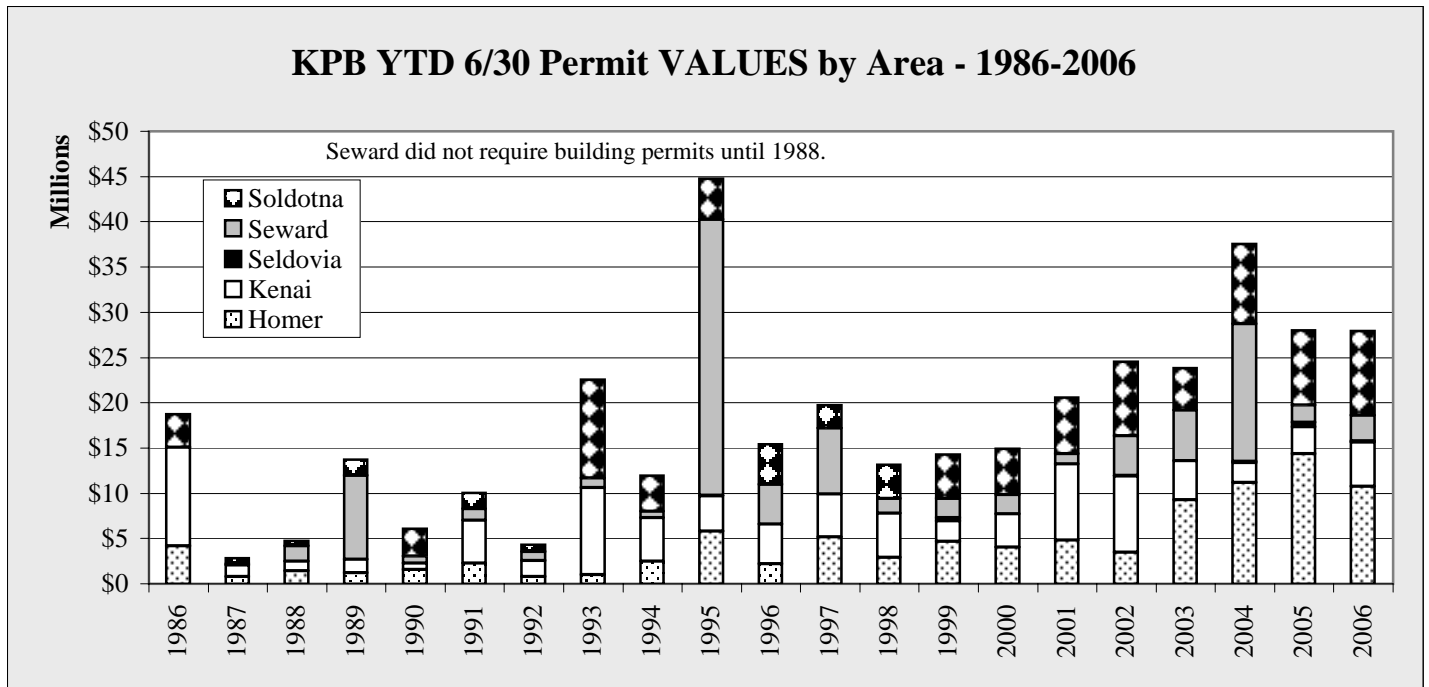

Chart 1.39

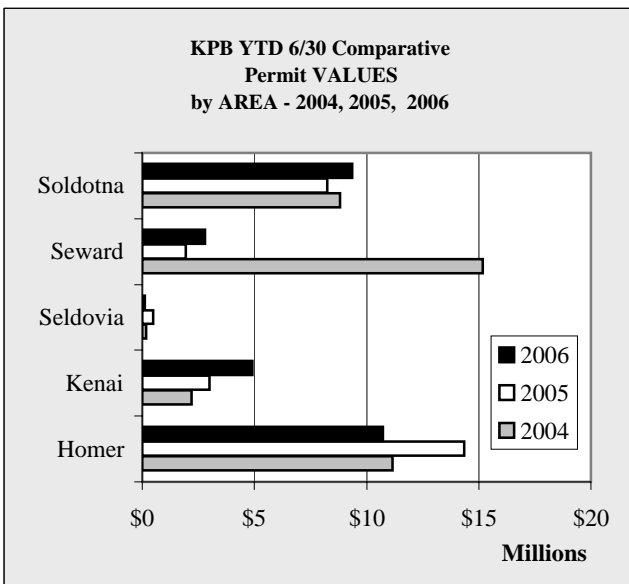

Chart 1.40

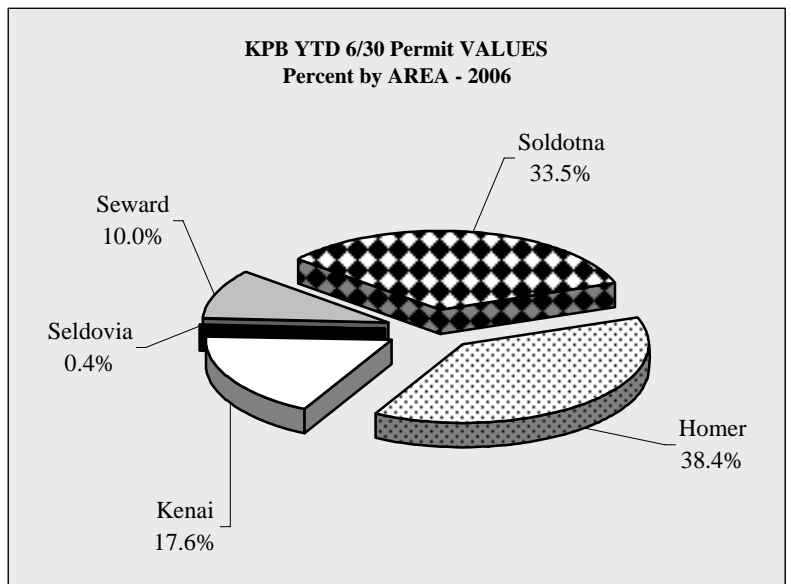

Chart 1.41

KPB Construction

KPB YTD 6/30 Permit VOLUME by AREA - 2001-2006 - in \$							
	2001	2002	2003	2004	2005	2006	Annual Change
Homer	41	27	52	42	65	53	-18.5%
Kenai	53	42	48	34	43	56	30.2%
Seldovia	2	3	3	4	7	7	0.0%
Seward	25	39	24	28	31	30	-3.2%
Soldotna	47	62	42	35	56	30	-46.4%
Total	168	173	169	143	202	176	-12.9%
Annual Change		3.0%	-2.3%	-15.4%	41.3%	-12.9%	

Table 1.46

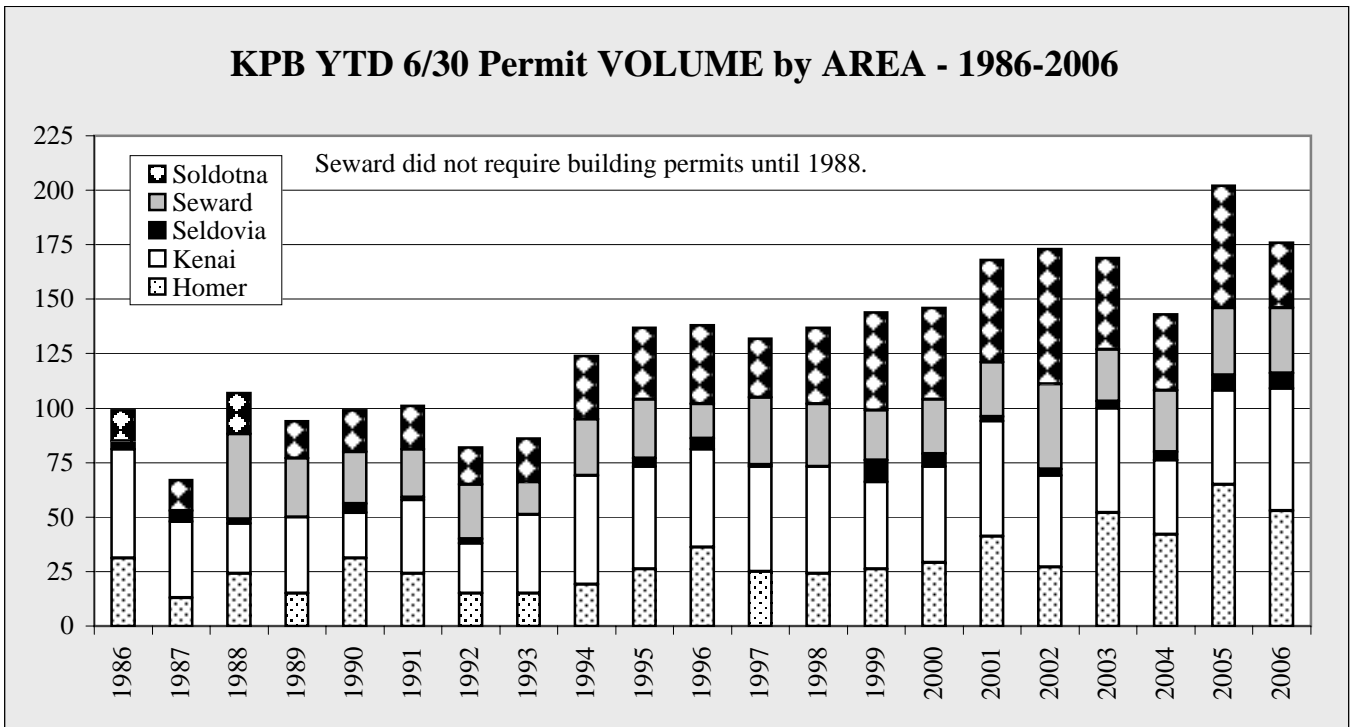

Chart 1.42

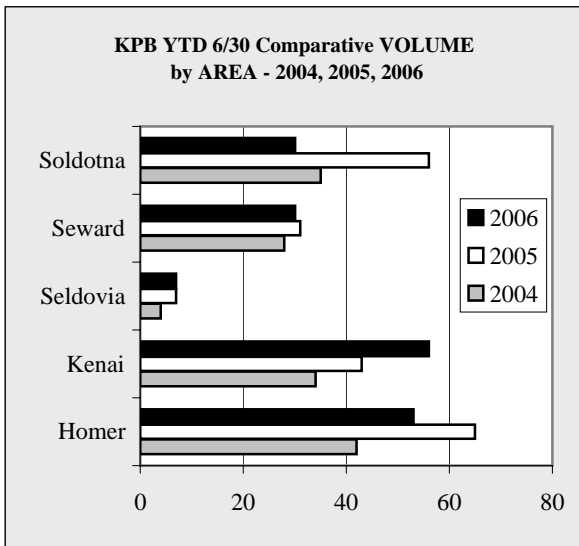

Chart 1.43

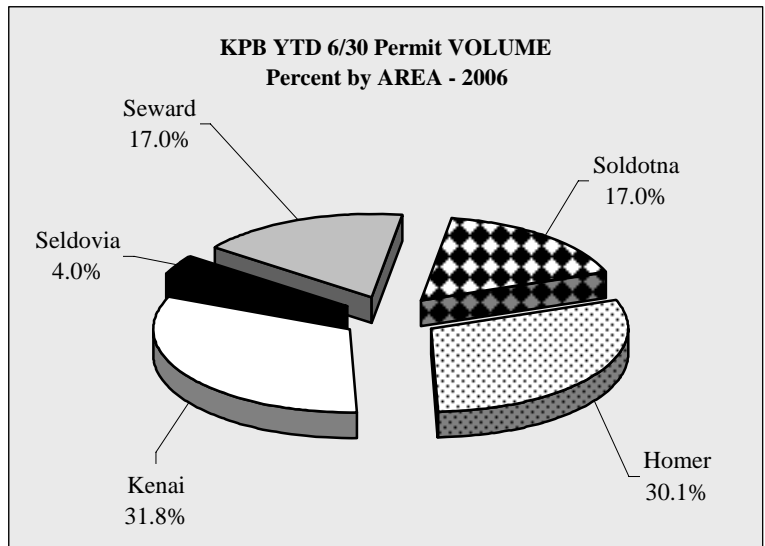

Chart 1.44

KPB Construction

KPB YTD 6/30 Permit VALUES by TYPE - 2001-2006 - in \$

	2001	2002	2003	2004	2005	2006	Annual Change
Residential New	8,290,801	7,677,362	8,966,634	9,831,284	10,898,855	12,476,630	14.5%
Residential Alter/Add	1,115,639	1,204,334	1,378,207	745,359	1,228,400	875,630	-28.7%
Commercial New	8,343,378	12,670,311	9,037,210	24,027,841	12,206,148	9,074,058	-25.7%
Commercial Alter/Add	2,859,969	2,959,897	4,437,046	2,927,243	3,666,927	5,504,040	50.1%
Total	20,609,787	24,511,904	23,819,097	37,531,727	28,000,330	27,930,358	-0.2%
Annual Change		18.9%	-2.8%	57.6%	-25.4%	-0.2%	

Table 1.47

KPB YTD 6/30 Permit VALUES by TYPE - 1986-2006

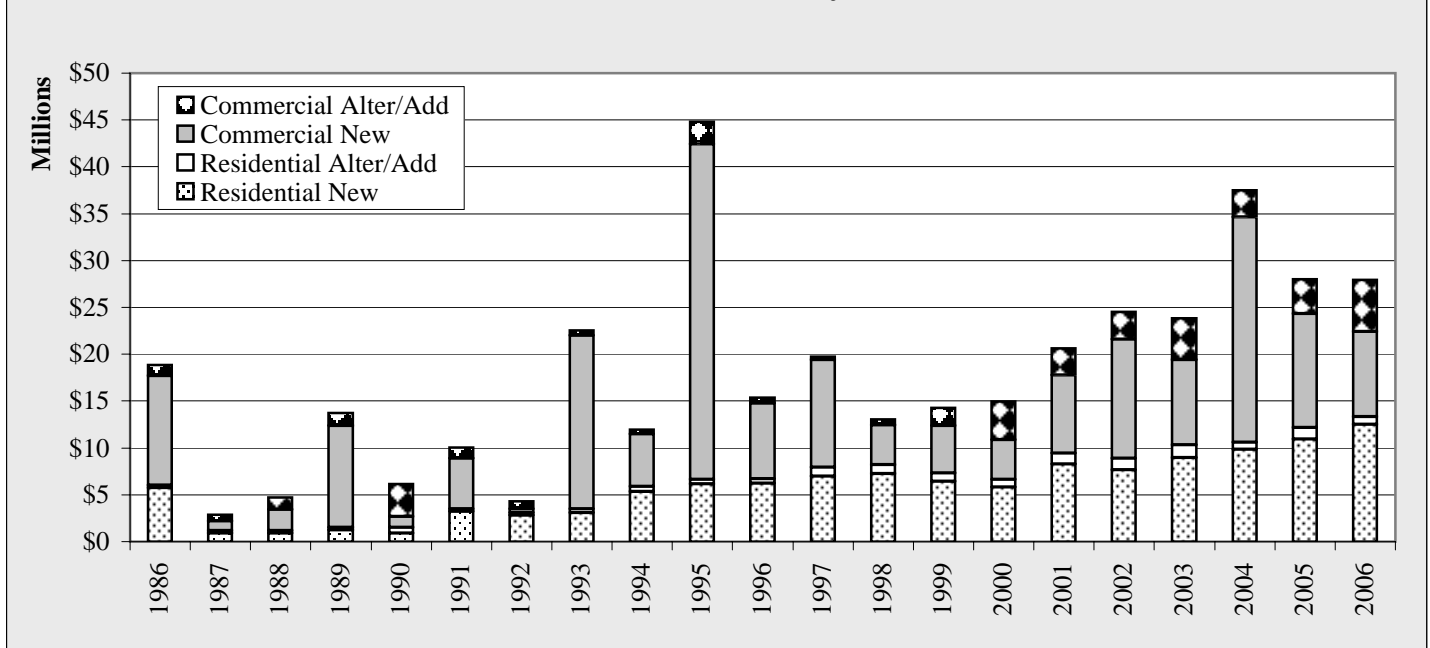

Chart 1.45

KPB YTD 6/30 Comparative Permit VALUES by TYPE - 2004, 2005, 2006

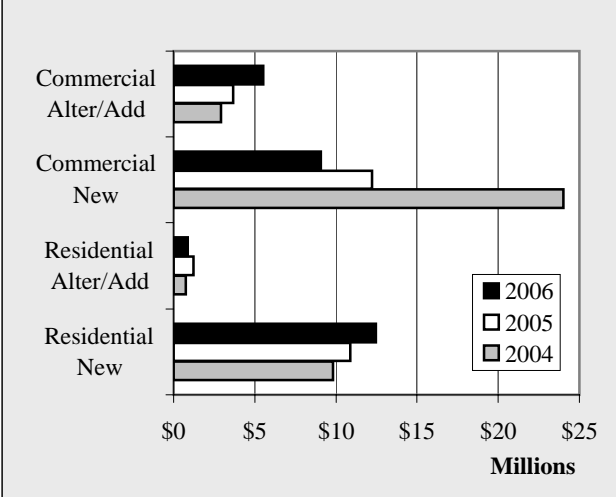

Chart 1.46

KPB YTD 6/30 Permit VALUES Percent by TYPE - 2006

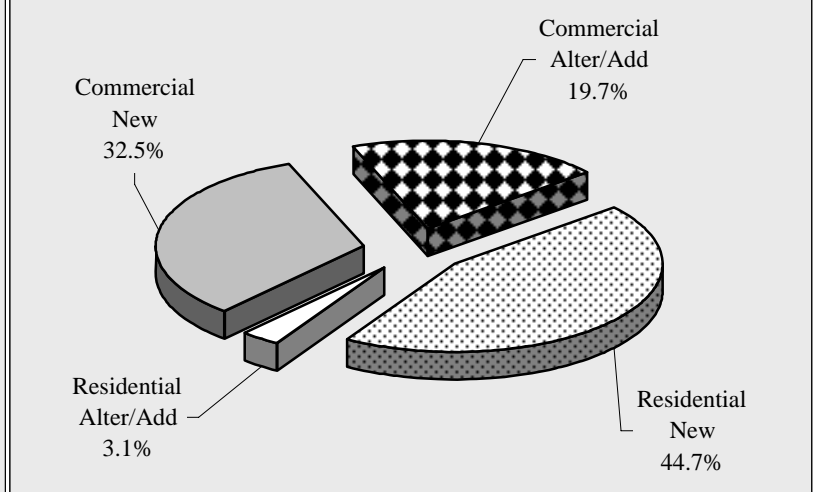

Chart 1.47

KPB Construction

KPB YTD 6/30 Permit VOLUME by TYPE - 2001-2006

	2001	2002	2003	2004	2005	2006	Annual Change
Residential New	52	57	54	51	67	70	4.5%
Residential Alter/Add	51	50	50	35	60	45	-25.0%
Commercial New	15	22	18	18	33	26	-21.2%
Commercial Alter/Add	50	44	47	39	42	35	-16.7%
Total	168	173	169	143	202	176	-12.9%
Annual Change		3.0%	-2.3%	-15.4%	41.3%	-12.9%	

Table 1.48

KPB YTD 6/30 Permit VOLUME by TYPE - 1986-2006

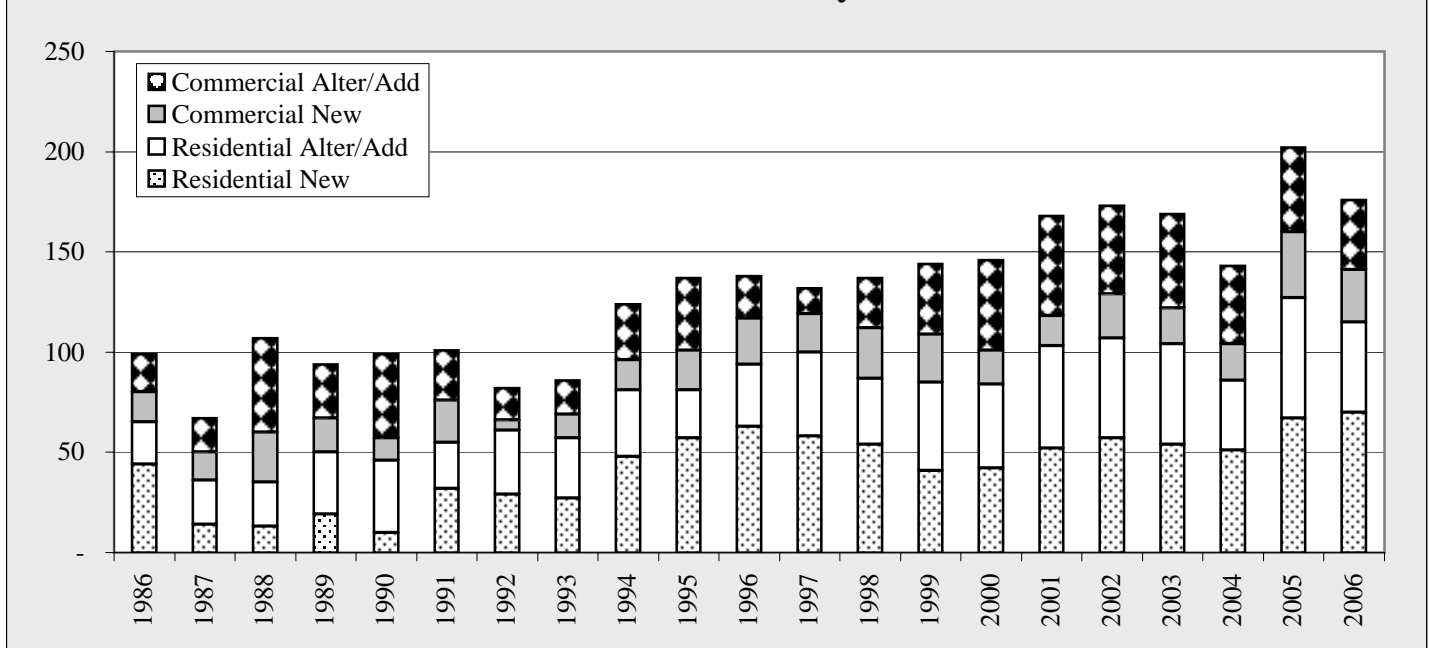

Chart 1.48

KPB YTD 6/30 Comparative Permit VOLUME by TYPE - 2004, 2005, 2006

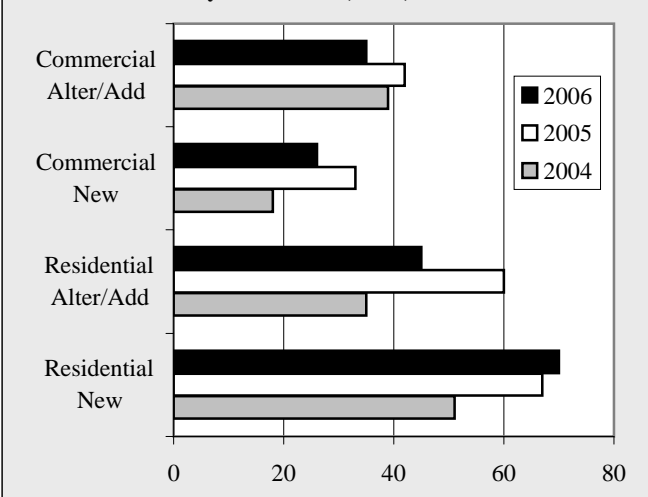

Chart 1.49

KPB YTD 6/30 Permit VOLUME Percent by TYPE - 2006

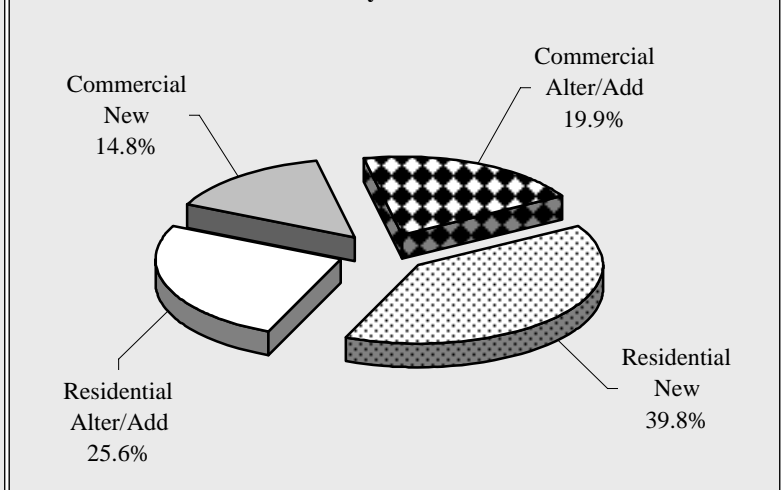

Chart 1.50

KPB Construction

KPB Annual Permit VALUES by AREA - 2000-2005 - in \$

	2000	2001	2002	2003	2004	2005	Annual Change
Homer	7,128,972	19,800,690	10,048,779	15,326,815	24,070,631	21,611,400	-10.2%
Kenai	9,398,100	13,578,900	16,799,400	10,441,800	4,786,550	8,237,900	72.1%
Seldovia	109,200	65,525	356,500	1,902,500	176,200	512,000	190.6%
Seward	3,451,565	2,716,981	7,910,703	7,982,765	17,711,150	2,863,143	-83.8%
Soldotna	8,167,420	8,954,972	11,163,894	7,952,297	37,296,926	11,509,360	-69.1%
Total	28,255,257	45,117,068	46,279,276	43,606,177	84,041,457	44,733,803	-46.8%
Annual Change		59.7%	2.6%	-5.8%	92.7%	-46.8%	

Table 1.49

KPB Annual Permit VALUES by AREA - 1986-2005

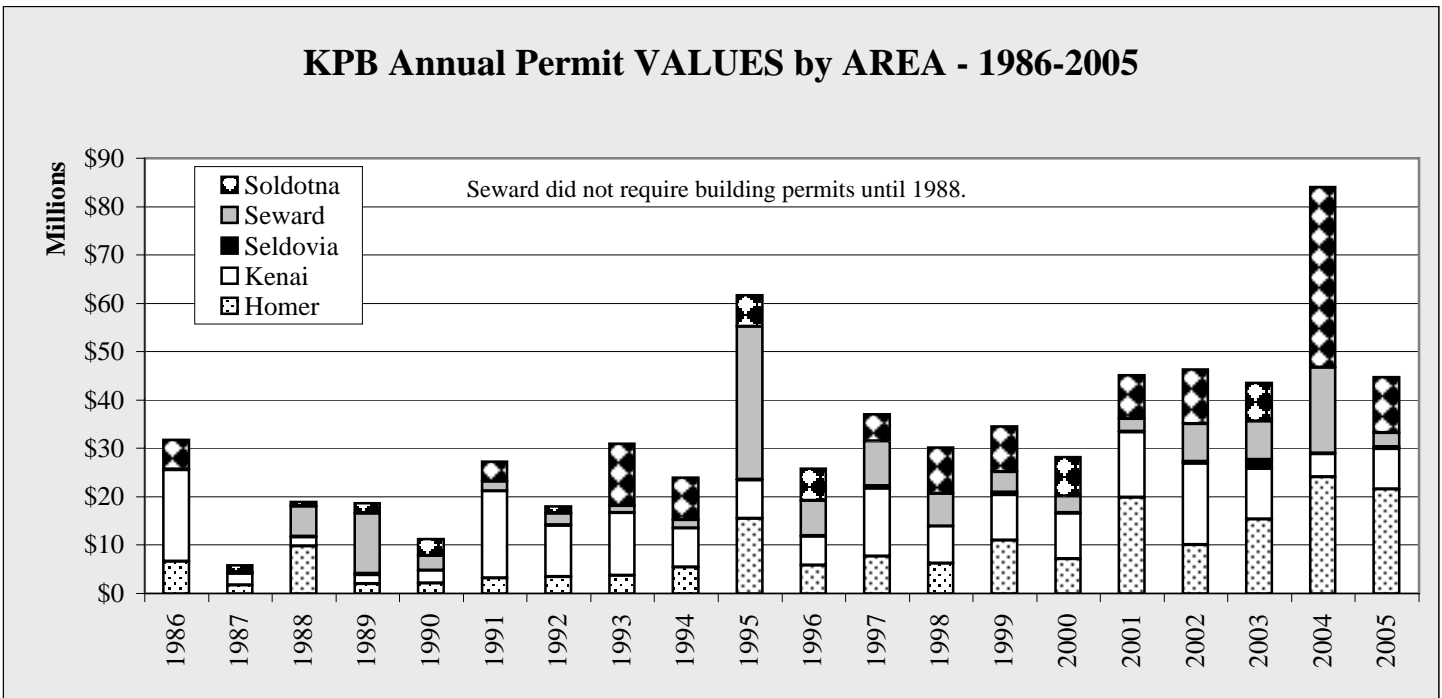

Chart 1.51

KPB Comparative Permit VALUES by AREA - 2003, 2004, 2005

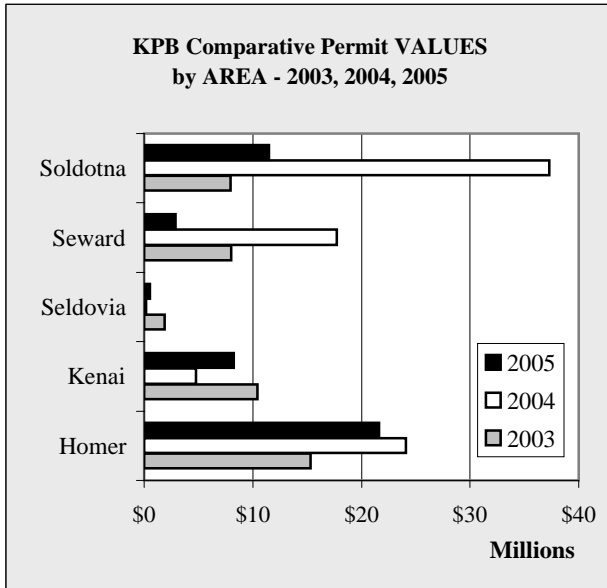

Chart 1.52

KPB Annual Permit VALUES Percent by AREA - 2005

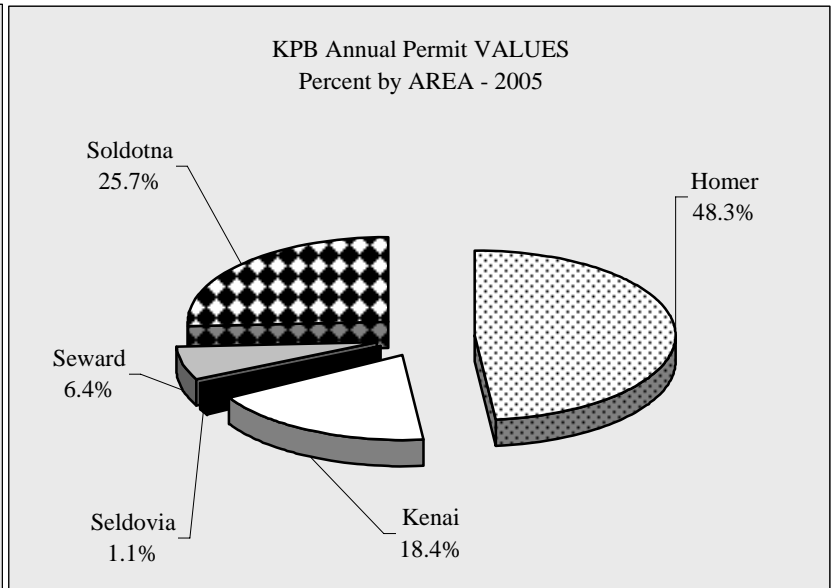

Chart 1.53

KPB Construction

KPB Annual Permit VOLUME by AREA- 2000-2005

	2000	2001	2002	2003	2004	2005	Annual Change
Homer	58	72	67	86	108	103	-4.6%
Kenai	93	87	121	114	79	90	13.9%
Seldovia	13	9	8	12	4	10	150.0%
Seward	51	48	64	50	54	54	0.0%
Soldotna	88	93	91	74	67	81	20.9%
Total	303	309	351	336	312	338	8.3%
Annual Change		2.0%	13.6%	-4.3%	-7.1%	8.3%	

Table 1.50

KPB Annual Permit VOLUME by AREA - 1986-2005

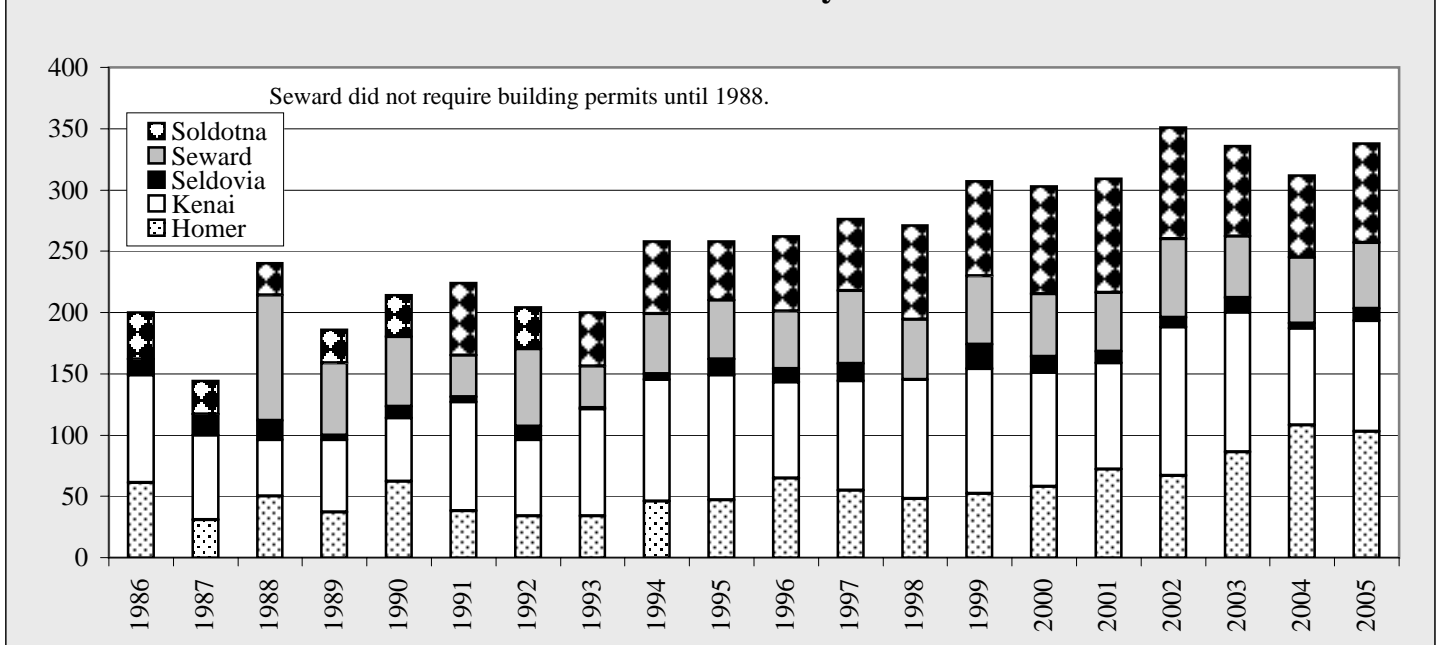

Chart 1.54

KPB Comparative Annual VOLUME by AREA - 2003, 2004, 2005



Chart 1.55

KPB Annual Permit VOLUME Percent by AREA - 2005

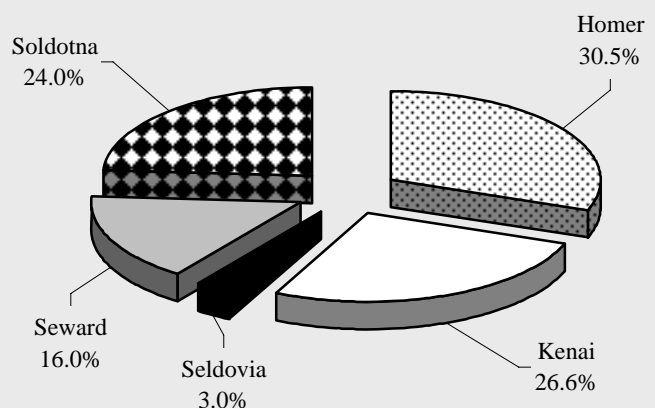

Chart 1.56

KPB Construction

KPB Annual Permit VALUES by TYPE - 2000-2005 - in \$

	2000	2001	2002	2003	2004	2005	Annual Change
Residential New	9,885,058	13,391,633	14,358,064	15,729,888	15,935,344	17,749,648	11.4%
Residential Alter/Add	1,990,399	1,996,494	2,305,815	2,280,779	2,880,284	2,235,128	-22.4%
Commercial New	10,662,544	11,565,350	21,793,729	15,820,201	56,079,343	19,217,548	-65.7%
Commercial Alter/Add	5,717,256	18,163,591	7,821,668	9,775,309	9,146,486	5,531,479	-39.5%
Total	28,255,257	45,117,068	46,279,276	43,606,177	84,041,457	44,733,803	-46.8%
Annual Change		59.7%	2.6%	-5.8%	92.7%	-46.8%	

Table 1.51

KPB Annual Permit VALUES by TYPE - 1986-2005

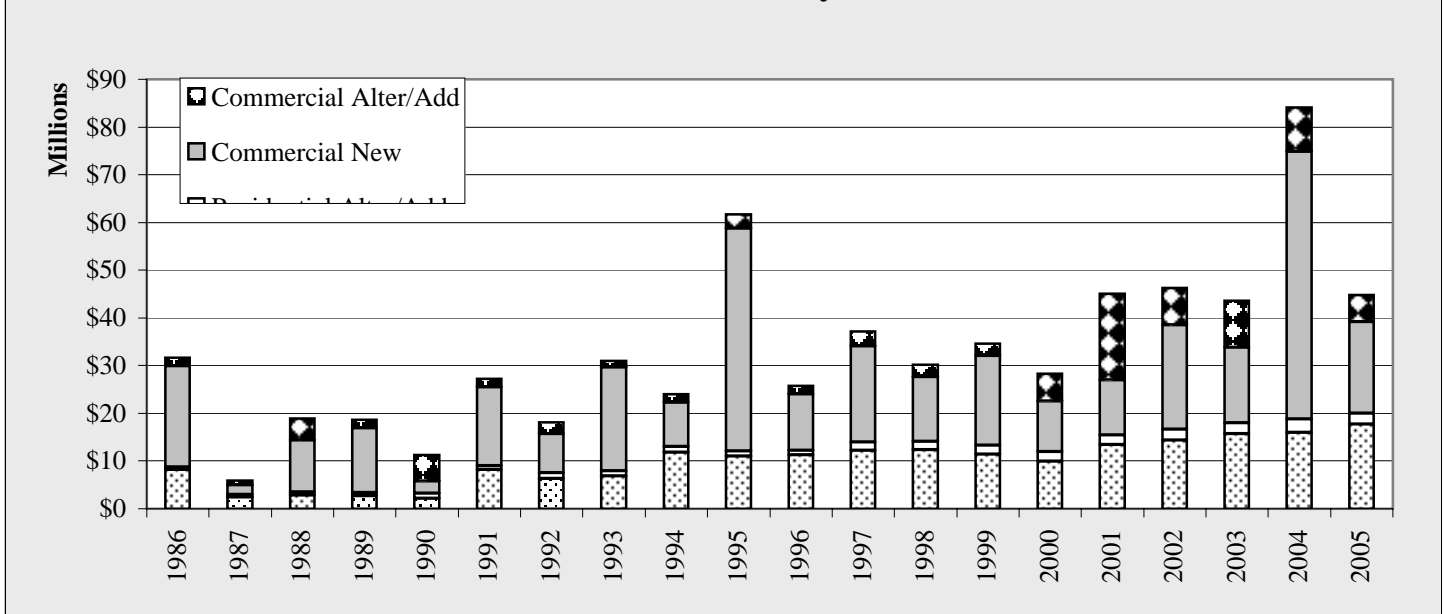

Chart 1.57

KPB Comparative Annual VALUES by TYPE - 2003, 2004, 2005

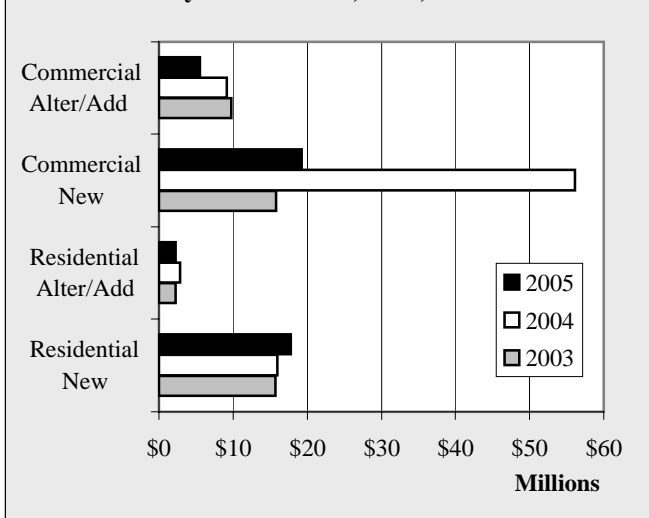

Chart 1.58

KPB Annual Permit VALUES Percent by TYPE - 2005

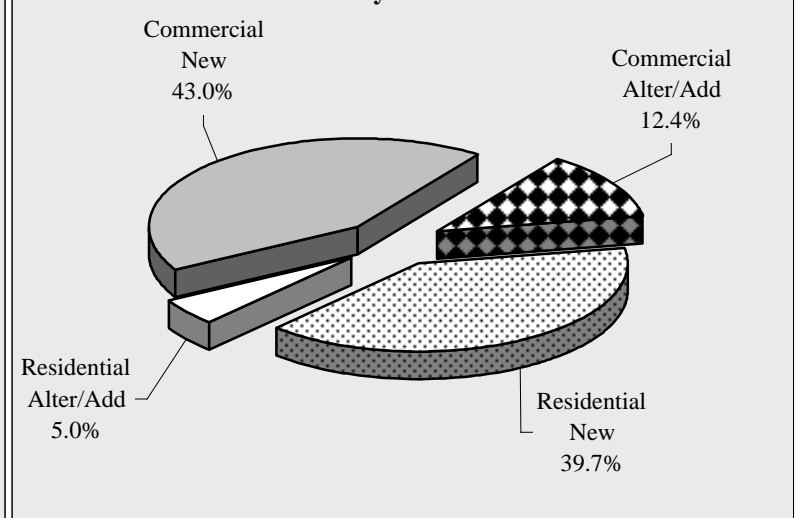

Chart 1.59

KPB Construction

KPB Annual Permit VOLUME by TYPE - 2000-2005

	2000	2001	2002	2003	2004	2005	Annual Change
Residential New	79	89	104	104	94	111	18.1%
Residential Alter/Add	97	96	116	94	96	106	10.4%
Commercial New	45	32	43	42	42	46	9.5%
Commercial Alter/Add	82	92	88	96	80	75	-6.3%
Total	303	309	351	336	312	338	8.3%
Annual Change		2.0%	13.6%	-4.3%	-7.1%	8.3%	

Table 1.52

KPB Annual Permit VOLUME by TYPE - 1986-2005

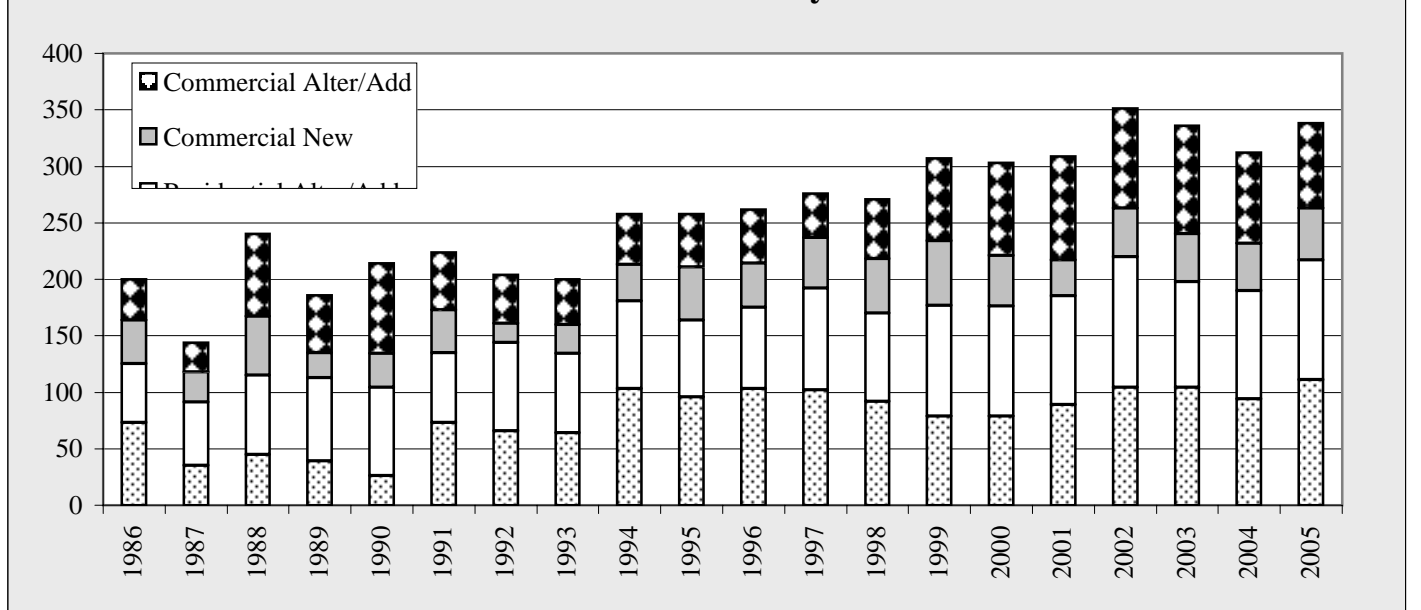

Chart 1.60

KPB Comparative Annual Permit VOLUME by TYPE - 2003, 2004, 2005

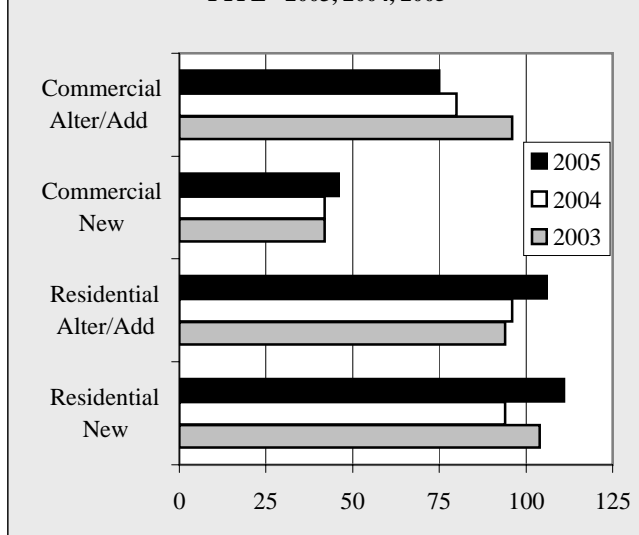

Chart 1.61

KPB Annual Permit VOLUME Percent by TYPE - 2005

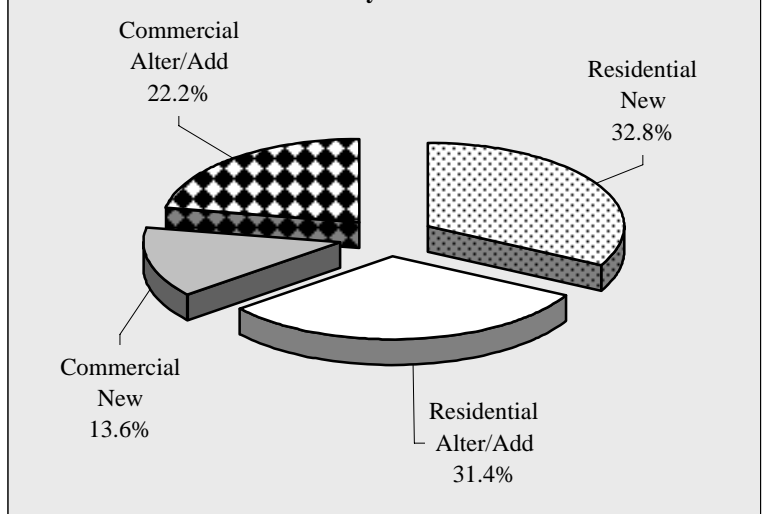

Chart 1.62

KPB Construction

KPB Annual Permit VALUES by AREA by Quarter - 2000-2006 - in \$					
	1st Quarter	2nd Quarter	3rd Quarter	4th Quarter	Total
2000					
Homer	1,798,100	2,265,920	2,146,970	917,982	7,128,972
Kenai	462,900	3,163,000	5,094,000	678,200	9,398,100
Seldovia	24,000	22,300	57,900	5,000	109,200
Seward	355,300	1,765,400	711,465	619,400	3,451,565
Soldotna	1,078,202	4,009,356	1,676,910	1,402,952	8,167,420
TOTAL	3,718,502	11,225,976	9,687,245	3,623,534	28,255,257
2001					
Homer	690,000	4,102,040	2,996,350	12,012,300	19,800,690
Kenai	819,500	7,597,900	4,506,200	655,300	13,578,900
Seldovia	10,000	25,000	15,525	15,000	65,525
Seward	416,700	666,239	642,042	992,000	2,716,981
Soldotna	3,051,218	3,231,190	2,509,916	162,648	8,954,972
TOTAL	4,987,418	15,622,369	10,670,033	13,837,248	45,117,068
2002					
Homer	928,720	2,528,209	5,777,330	814,520	10,048,779
Kenai	3,888,200	4,569,400	6,814,000	1,527,800	16,799,400
Seldovia	10,000	8,000	318,500	20,000	356,500
Seward	481,440	3,888,887	1,307,576	2,232,800	7,910,703
Soldotna	1,205,590	7,003,458	2,697,346	257,500	11,163,894
TOTAL	6,513,950	17,997,954	16,914,752	4,852,620	46,279,276
2003					
Homer	1,334,340	7,929,500	3,020,075	3,042,900	15,326,815
Kenai	1,557,600	2,728,350	3,700,350	2,455,500	10,441,800
Seldovia	31,000	0	1,835,000	36,500	1,902,500
Seward	1,905,355	3,672,010	1,832,900	572,500	7,982,765
Soldotna	427,018	4,233,924	2,418,310	873,045	7,952,297
TOTAL	5,255,313	18,563,784	12,806,635	6,980,445	43,606,177
2004					
Homer	3,714,020	7,433,711	9,531,900	3,391,000	24,070,631
Kenai	312,000	1,897,400	1,991,750	585,400	4,786,550
Seldovia	20,000	156,200	0	0	176,200
Seward	7,741,600	7,443,900	2,266,300	259,350	17,711,150
Soldotna	5,064,323	3,748,573	23,780,115	4,703,915	37,296,926
TOTAL	16,851,943	20,679,784	37,570,065	8,939,665	84,041,457
2005					
Homer	3,105,900	11,246,000	4,282,500	2,977,000	21,611,400
Kenai	425,500	2,557,300	4,035,100	1,220,000	8,237,900
Seldovia	15,000	466,000	30,500	500	512,000
Seward	1,172,300	758,540	825,446	106,857	2,863,143
Soldotna	1,421,555	6,832,235	3,085,730	169,840	11,509,360
TOTAL	6,140,255	21,860,075	12,229,276	4,474,197	44,733,803
2006					
				Year to Date	
Homer	3,271,000	7,467,100	0	0	10,738,100
Kenai	763,500	4,157,100	0	0	4,920,600
Seldovia	30,000	87,000	0	0	117,000
Seward	622,217	2,184,672	0	0	2,806,889
Soldotna	2,116,441	7,231,328	0	0	9,347,769
TOTAL	6,803,158	21,127,200	0	0	27,930,358

Table 1.53

KPB Construction

KPB Annual Permit VOLUME by AREA by Quarter - 2000-2006					
	1st Quarter	2nd Quarter	3rd Quarter	4th Quarter	Total
2000					
Homer	9	20	21	8	58
Kenai	8	36	36	13	93
Seldovia	3	3	6	1	13
Seward	5	20	17	9	51
Soldotna	8	34	26	20	88
TOTAL	33	113	106	51	303
2001					
Homer	7	34	22	9	72
Kenai	11	42	23	11	87
Seldovia	1	1	5	2	9
Seward	11	14	14	9	48
Soldotna	10	37	35	11	93
TOTAL	40	128	99	42	309
2002					
Homer	10	17	27	13	67
Kenai	5	37	59	20	121
Seldovia	1	2	4	1	8
Seward	10	29	14	11	64
Soldotna	11	51	25	4	91
TOTAL	37	136	129	49	351
2003					
Homer	18	34	21	13	86
Kenai	8	40	45	21	114
Seldovia	3	0	5	4	12
Seward	11	13	15	11	50
Soldotna	6	36	19	13	74
TOTAL	46	123	105	62	336
2004					
Homer	16	26	42	24	108
Kenai	4	30	31	14	79
Seldovia	1	3	0	0	4
Seward	7	21	19	7	54
Soldotna	9	26	24	8	67
TOTAL	37	106	116	53	312
2005					
Homer	18	47	27	11	103
Kenai	10	33	33	14	90
Seldovia	1	6	2	1	10
Seward	12	19	16	7	54
Soldotna	16	40	20	5	81
TOTAL	57	145	98	38	338
2006					
	Year to Date				
Homer	14	39			53
Kenai	14	42			56
Seldovia	1	6			7
Seward	7	23			30
Soldotna	5	25			30
TOTAL	41	135	0	0	176

Table 1.54

KPB Construction

KPB Annual Permit VALUES by TYPE by Quarter - 2000-2006 - in \$					
	1st Quarter	2nd Quarter	3rd Quarter	4th Quarter	Total
2000					
Residential - New	1,242,529	4,531,931	3,137,930	972,668	9,885,058
Residential - Add/Alter	18,500	860,574	672,025	439,300	1,990,399
Commercial - New	669,273	3,564,122	4,966,665	1,462,484	10,662,544
Commercial - Add/Alter	1,788,200	2,269,349	910,625	749,082	5,717,256
TOTAL	3,718,502	11,225,976	9,687,245	3,623,534	28,255,257
2001					
Residential - New	923,000	7,367,801	3,984,532	1,116,300	13,391,633
Residential - Add/Alter	356,860	758,779	531,907	348,948	1,996,494
Commercial - New	2,958,578	5,384,800	2,707,972	514,000	11,565,350
Commercial - Add/Alter	748,980	2,110,989	3,445,622	11,858,000	18,163,591
TOTAL	4,987,418	15,622,369	10,670,033	13,837,248	45,117,068
2002					
Residential - New	1,531,609	6,145,753	5,567,502	1,113,200	14,358,064
Residential - Add/Alter	159,391	1,044,943	875,861	225,620	2,305,815
Commercial - New	4,294,006	8,376,305	5,955,418	3,168,000	21,793,729
Commercial - Add/Alter	528,944	2,430,953	4,515,971	345,800	7,821,668
TOTAL	6,513,950	17,997,954	16,914,752	4,852,620	46,279,276
2003					
Residential - New	1,097,800	7,868,834	4,209,163	2,554,091	15,729,888
Residential - Add/Alter	393,867	984,340	611,572	291,000	2,280,779
Commercial - New	72,000	8,965,210	4,636,000	2,146,991	15,820,201
Commercial - Add/Alter	3,691,646	745,400	3,349,900	1,988,363	9,775,309
TOTAL	5,255,313	18,563,784	12,806,635	6,980,445	43,606,177
2004					
Residential - New	3,456,797	6,374,487	4,950,200	1,153,860	15,935,344
Residential - Add/Alter	261,520	483,839	1,605,471	529,454	2,880,284
Commercial - New	12,880,026	11,147,815	28,989,901	3,061,601	56,079,343
Commercial - Add/Alter	253,600	2,673,643	2,024,493	4,194,750	9,146,486
TOTAL	16,851,943	20,679,784	37,570,065	8,939,665	84,041,457
2005					
Residential - New	3,338,356	7,560,499	4,843,170	2,007,623	17,749,648
Residential - Add/Alter	415,930	812,470	805,771	200,957	2,235,128
Commercial - New	309,000	11,897,148	4,848,400	2,163,000	19,217,548
Commercial - Add/Alter	2,076,969	1,589,958	1,761,935	102,617	5,531,479
TOTAL	6,140,255	21,860,075	12,259,276	4,474,197	44,733,803
2006					
					Year to Date
Residential - New	2,257,031	10,219,599			12,476,630
Residential - Add/Alter	45,000	830,630			875,630
Commercial - New	938,410	8,135,648			9,074,058
Commercial - Add/Alter	3,562,717	1,941,323			5,504,040
TOTAL	6,803,158	21,127,200	0	0	27,930,358

Table 1.55

KPB Construction

KPB Annual Permit VOLUME by TYPE by Quarter - 2000-2006					
	1st Quarter	2nd Quarter	3rd Quarter	4th Quarter	Total
2000					
Residential - New	10	32	28	9	79
Residential - Add/Alter	4	38	40	15	97
Commercial - New	4	13	16	12	45
Commercial - Add/Alter	15	30	22	15	82
TOTAL	33	113	106	51	303
2001					
Residential - New	7	45	29	8	89
Residential - Add/Alter	13	38	31	14	96
Commercial - New	6	9	15	2	32
Commercial - Add/Alter	14	36	24	18	92
TOTAL	40	128	99	42	309
2002					
Residential - New	12	45	38	9	104
Residential - Add/Alter	8	42	49	17	116
Commercial - New	5	17	14	7	43
Commercial - Add/Alter	12	32	28	16	88
TOTAL	37	136	129	49	351
2003					
Residential - New	7	47	28	22	104
Residential - Add/Alter	17	33	34	10	94
Commercial - New	1	17	17	7	42
Commercial - Add/Alter	21	26	26	23	96
TOTAL	46	123	105	62	336
2004					
Residential - New	17	34	32	11	94
Residential - Add/Alter	5	30	44	17	96
Commercial - New	7	11	15	9	42
Commercial - Add/Alter	8	31	25	16	80
TOTAL	37	106	116	53	312
2005					
Residential - New	18	49	31	13	111
Residential - Add/Alter	14	46	36	10	106
Commercial - New	6	27	9	4	46
Commercial - Add/Alter	19	23	22	11	75
TOTAL	57	145	98	38	338
2006					Year to Date
Residential - New	13	57			70
Residential - Add/Alter	5	40			45
Commercial - New	4	22			26
Commercial - Add/Alter	19	16			35
TOTAL	41	135	0	0	176

Table 1.56

KPB Employment

Employment data are acquired from the Alaska Department of Labor and Workforce Development (AK DOLWD) as reported by each business.

Government employees include federal, state, borough and local government employees as well as persons employed by public school and the state university. Employees of both Central Peninsula General Hospital in Soldotna and South Peninsula General Hospital in Homer are included in government data rather than service data because they are owned by and receive funds from the KPB.

The AK DOLWD updates employment data regularly. Self-employed workers, fishers, domestics, unpaid family help, most individuals engaged in agriculture and some other smaller worker groups are excluded from these figures due to exemption from certain reporting requirements.

A change in the way the labor force statistics are calculated for boroughs and census areas makes data prior to 2000 not comparable with data from 2000 forward. Please contact the Alaska Department of Labor for any questions.

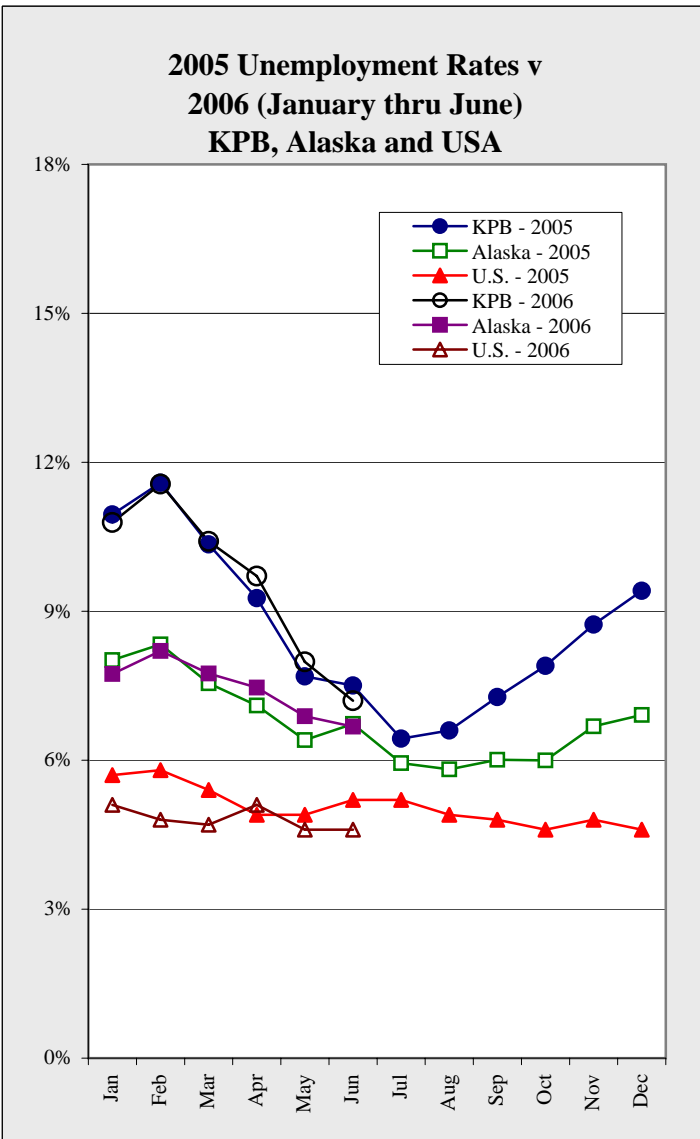

Chart 1.64

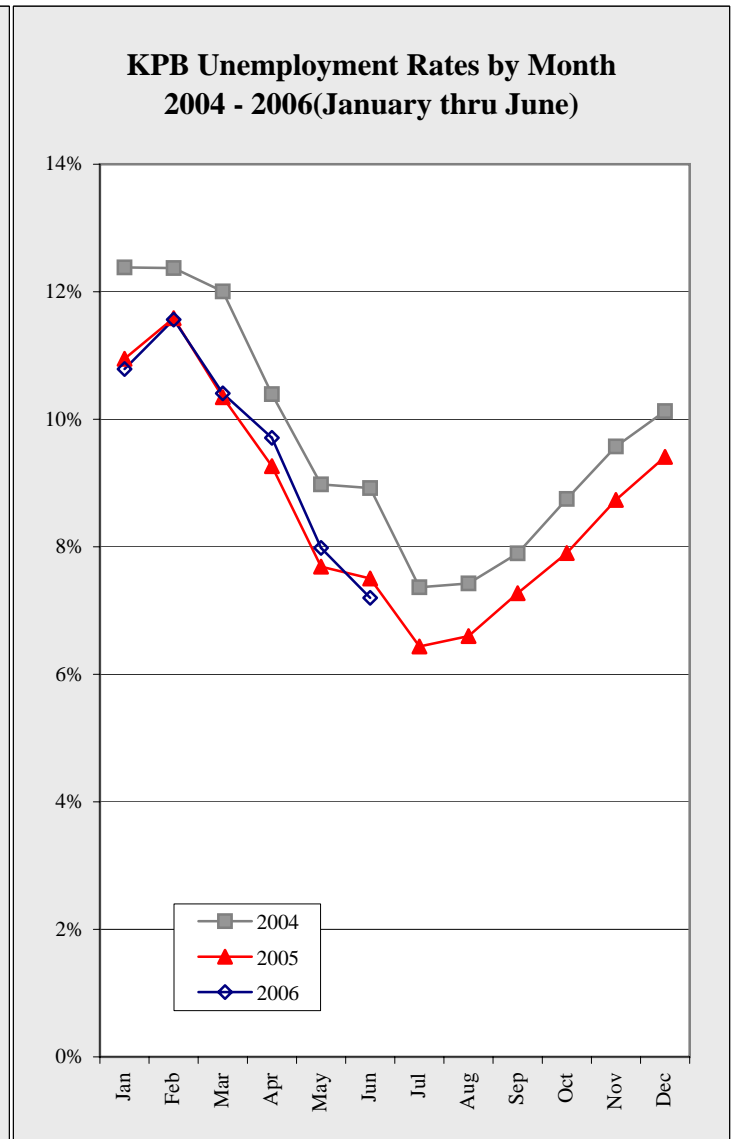

Chart 1.63

KPB Employment

KPB Labor Force by Month - 1990-2006(Q2)													
	Jan	Feb	Mar	Apr	May	Jun	Jul	Aug	Sep	Oct	Nov	Dec	Avg
1990	17,564	17,961	17,955	18,541	19,221	20,270	21,443	20,938	18,577	18,540	17,994	17,794	18,900
1991	18,381	18,683	18,701	19,243	19,674	20,785	22,469	21,530	19,892	19,111	18,966	18,699	19,678
1992	18,890	19,623	19,381	19,559	20,145	22,134	22,742	21,332	20,508	20,292	19,350	19,145	20,258
1993	18,480	19,492	19,749	19,900	20,254	22,689	24,023	22,948	20,520	20,560	19,705	19,339	20,638
1994	19,567	21,120	21,186	20,476	20,925	23,088	24,503	23,230	20,969	20,793	19,887	19,262	21,251
1995	20,592	21,194	20,910	20,449	20,994	22,646	24,230	23,407	21,538	21,337	20,292	19,807	21,450
1996	20,912	21,826	21,731	21,498	22,549	23,867	25,493	24,772	23,126	21,813	21,211	20,474	22,439
1997	21,692	22,407	21,900	21,940	21,929	24,014	25,338	24,296	22,369	21,180	20,448	19,878	22,283
1998	20,924	21,090	20,751	20,663	21,492	23,562	24,276	23,694	22,385	21,085	20,105	19,805	21,653
1999	20,653	21,359	21,279	21,368	21,936	23,579	24,619	23,921	22,572	21,575	20,663	20,119	21,970
2000	23,011	23,329	23,290	23,365	24,542	26,598	26,448	26,243	25,160	24,101	24,071	24,174	24,528
2001	23,056	23,003	23,055	23,139	24,195	26,114	26,836	25,619	24,496	23,717	23,656	23,801	24,224
2002	23,659	23,374	23,569	24,173	24,925	25,919	26,796	26,125	24,942	24,317	24,294	24,409	24,709
2003	24,298	24,108	24,243	24,379	25,394	26,781	27,170	26,352	24,571	24,028	23,988	23,875	24,932
2004	23,874	24,000	24,130	24,130	25,302	27,119	27,599	26,342	24,958	24,334	24,116	23,981	24,990
2005	23,977	23,941	24,094	24,081	25,254	26,855	27,547	26,324	24,873	24,309	23,952	23,897	24,925
2006	23,700	23,853	23,993	23,790	25,215	26,791							

Table 1.57

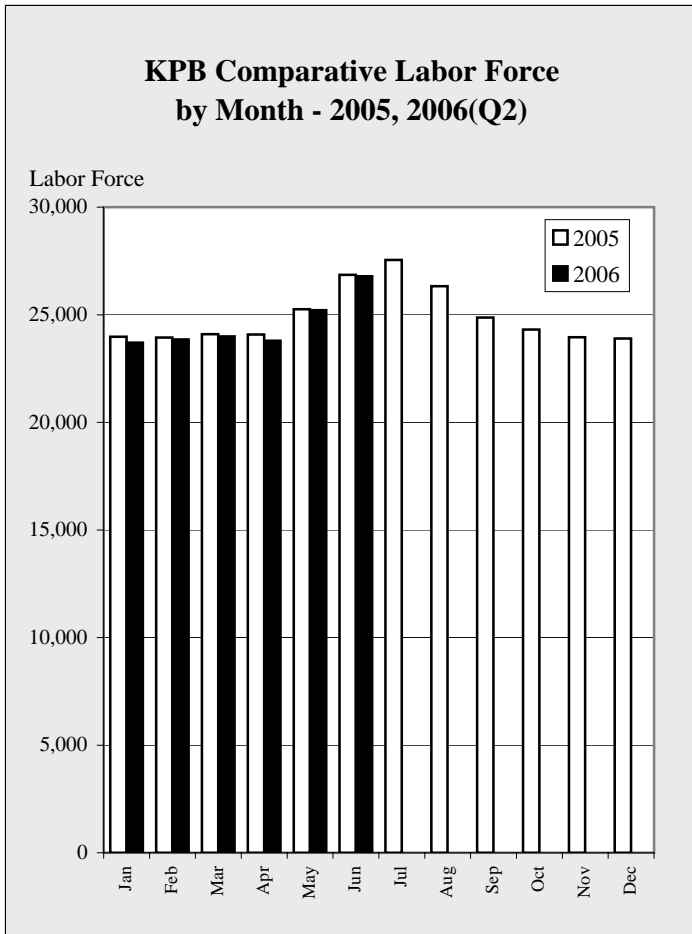

Chart 1.65



Chart 1.66

KPB Employment

KPB Unemployment by Month - 1990-2006(Q2)													
	Jan	Feb	Mar	Apr	May	Jun	Jul	Aug	Sep	Oct	Nov	Dec	Avg
1990	2,680	2,704	2,484	2,300	2,072	1,938	1,671	1,768	1,929	2,374	2,325	2,317	2,214
1991	2,929	3,023	2,818	2,611	2,323	2,345	2,201	2,078	2,200	2,874	3,348	3,490	2,687
1992	4,153	4,426	3,807	3,385	3,008	3,016	2,564	2,064	2,259	2,960	2,944	3,025	3,134
1993	3,596	3,823	3,357	3,014	2,494	2,439	2,004	1,769	1,752	2,503	2,603	2,660	2,668
1994	3,386	3,668	3,333	2,923	2,533	2,425	2,402	1,988	1,844	2,638	2,481	2,716	2,695
1995	3,616	3,651	3,146	2,638	2,196	2,196	2,154	1,933	1,897	2,654	2,717	2,931	2,644
1996	3,791	4,034	3,447	3,164	2,872	2,680	2,544	2,207	2,676	3,214	3,484	3,512	3,135
1997	4,509	4,549	3,911	3,394	2,709	2,710	2,379	2,054	2,118	2,619	2,675	2,647	3,023
1998	3,051	3,014	2,567	2,147	1,788	1,981	1,644	1,441	1,666	2,002	1,941	2,120	2,114
1999	2,779	3,247	2,779	2,420	2,097	2,119	2,026	1,942	2,076	2,317	2,430	2,549	2,398
2000	2,530	2,575	2,445	2,138	1,943	1,843	1,546	1,556	1,496	1,671	1,871	2,019	1,969
2001	2,327	2,379	2,276	2,045	1,767	1,813	1,543	1,560	1,560	1,754	1,965	2,181	1,931
2002	2,503	2,518	2,542	2,335	2,117	2,207	1,981	2,007	2,092	2,247	2,466	2,690	2,309
2003	2,935	3,048	2,795	2,564	2,345	2,542	2,169	2,122	2,126	2,301	2,508	2,636	2,508
2004	2,956	2,969	2,897	2,508	2,272	2,419	2,033	1,956	1,971	2,129	2,309	2,429	2,404
2005	2,625	2,774	2,493	2,231	1,942	2,015	1,773	1,737	1,809	1,921	2,092	2,249	2,138
2006	2,557	2,758	2,497	2,310	2,013	1,929							

Table 1.58

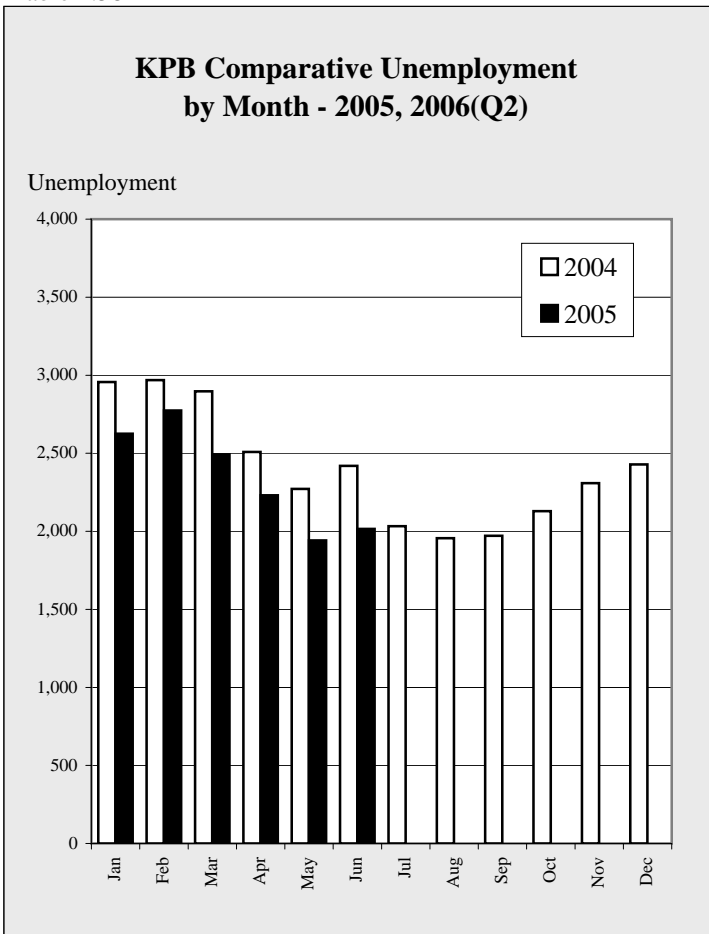

Chart 1.67

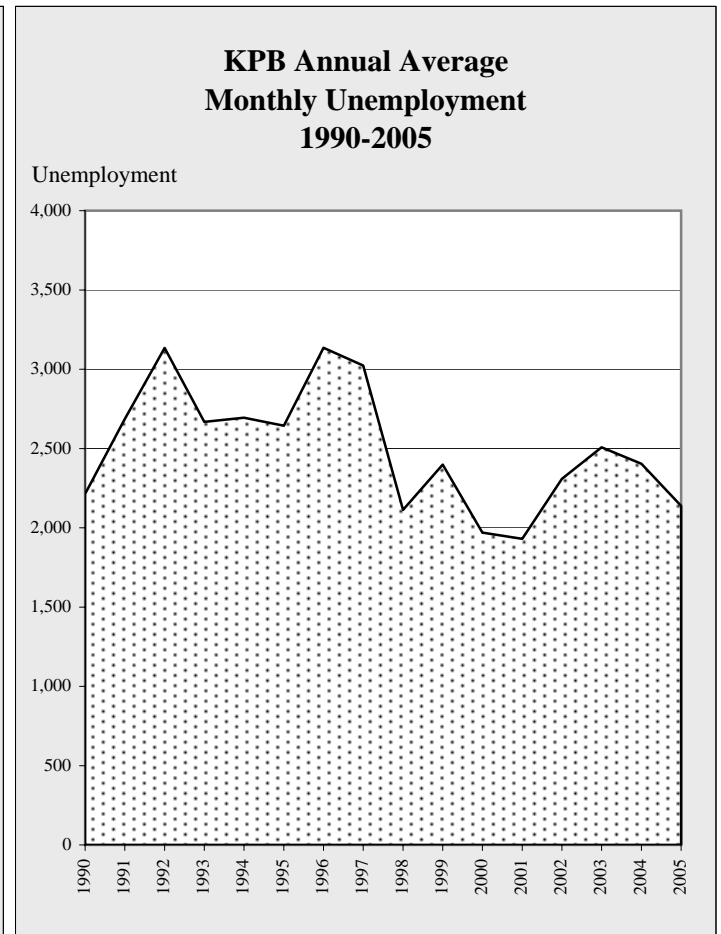

Chart 1.68

KPB Employment

KPB Unemployment Rates by Month - 1990-2006(Q2)													
	Jan	Feb	Mar	Apr	May	Jun	Jul	Aug	Sep	Oct	Nov	Dec	Avg
1990	15.3%	15.1%	13.8%	12.4%	10.8%	9.6%	7.8%	8.4%	10.4%	12.8%	12.9%	13.0%	11.9%
1991	15.9%	16.2%	15.1%	13.6%	11.8%	11.3%	9.8%	9.7%	11.1%	15.0%	17.7%	18.7%	13.8%
1992	22.0%	22.6%	19.6%	17.3%	14.9%	13.6%	11.3%	9.7%	11.0%	14.6%	15.2%	15.8%	15.6%
1993	19.5%	19.6%	17.0%	15.1%	12.3%	10.7%	8.3%	7.7%	8.5%	12.2%	13.2%	13.8%	13.2%
1994	17.3%	17.4%	15.7%	14.3%	12.1%	10.5%	9.8%	8.6%	8.8%	12.7%	12.5%	14.1%	12.8%
1995	17.6%	17.2%	15.0%	12.9%	10.5%	9.7%	8.9%	8.3%	8.8%	12.4%	13.4%	14.8%	12.5%
1996	18.1%	18.5%	15.9%	14.7%	12.7%	11.2%	10.0%	8.9%	11.6%	14.7%	16.4%	17.2%	14.2%
1997	20.8%	20.3%	17.9%	15.5%	12.4%	11.3%	9.4%	8.5%	9.5%	12.4%	13.1%	13.3%	13.7%
1998	14.6%	14.3%	12.4%	10.4%	8.3%	8.4%	6.8%	6.1%	7.4%	9.5%	9.7%	10.7%	9.9%
1999	13.5%	15.2%	13.1%	11.3%	9.6%	9.0%	8.2%	8.1%	9.2%	10.7%	11.8%	12.7%	11.0%
2000	11.0%	11.0%	10.5%	9.2%	7.9%	6.9%	5.8%	5.9%	5.9%	6.9%	7.8%	8.4%	8.1%
2001	10.1%	10.3%	9.9%	8.8%	7.3%	6.9%	5.7%	6.1%	6.4%	7.4%	8.3%	9.2%	8.0%
2002	10.6%	10.8%	10.8%	9.7%	8.5%	8.5%	7.4%	7.7%	8.4%	9.2%	10.2%	11.0%	9.4%
2003	12.1%	12.6%	11.5%	10.5%	9.2%	9.5%	8.0%	8.1%	8.7%	9.6%	10.5%	11.0%	10.1%
2004	12.4%	12.4%	12.0%	10.4%	9.0%	8.9%	7.4%	7.4%	7.9%	8.7%	9.6%	10.1%	9.7%
2005	10.9%	11.6%	10.3%	9.3%	7.7%	7.5%	6.4%	6.6%	7.3%	7.9%	8.7%	9.4%	8.6%
2006	10.8%	11.6%	10.4%	9.7%	8.0%	7.2%							

Table 1.59

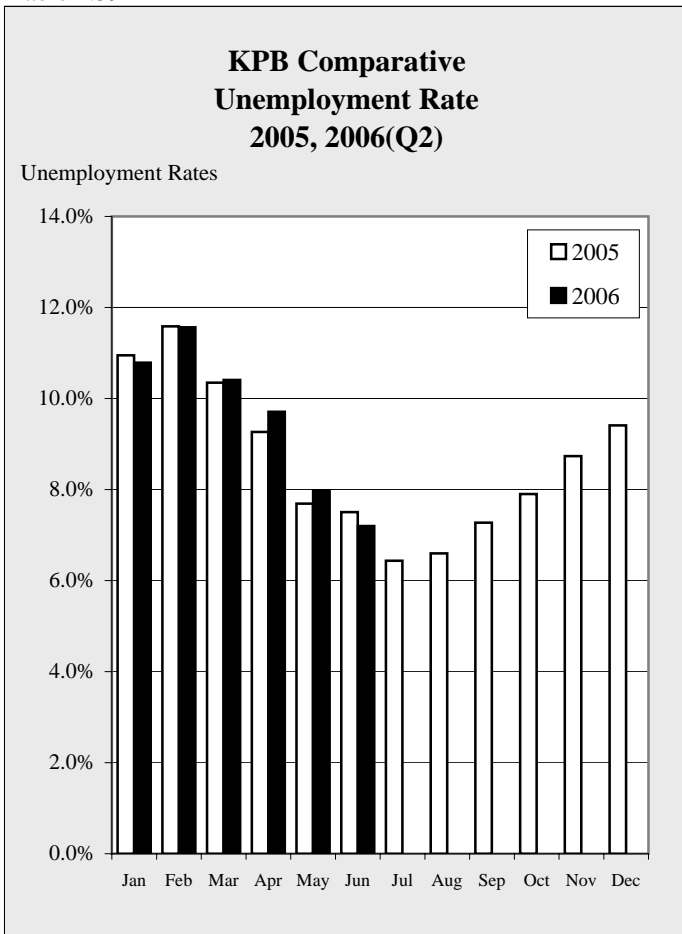

Chart 1.69

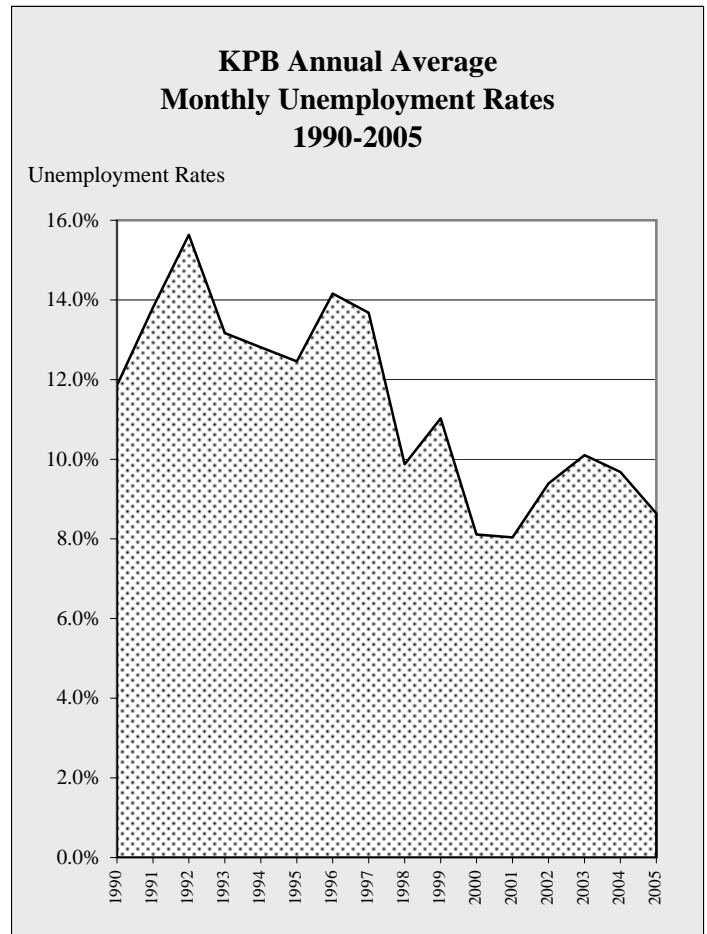

Chart 1.70

KPB Employment

KPB Employment by Month - 1990-2006 (Q2)													
	Jan	Feb	Mar	Apr	May	Jun	Jul	Aug	Sep	Oct	Nov	Dec	Avg
1990	14,800	15,163	15,456	16,241	17,046	18,312	19,846	19,262	16,707	16,208	15,756	15,496	16,691
1991	15,420	15,652	15,969	16,834	17,423	18,471	20,346	19,563	17,778	16,145	15,521	15,051	17,014
1992	14,576	15,080	15,590	16,299	17,137	19,156	20,256	19,405	18,381	17,329	16,426	16,082	17,143
1993	14,882	15,693	16,486	17,091	17,863	20,352	22,136	21,336	18,902	18,043	17,151	16,607	18,045
1994	16,205	17,470	17,911	17,624	18,429	20,747	22,221	21,452	19,259	18,234	17,511	16,639	18,642
1995	17,014	17,556	17,828	17,855	18,862	20,502	22,203	21,635	19,695	28,715	17,634	16,949	19,704
1996	17,153	17,792	18,284	18,334	19,677	21,187	22,949	22,565	20,450	18,599	17,727	16,962	19,307
1997	17,286	17,858	17,989	18,546	19,220	21,304	22,959	22,242	20,251	18,561	17,773	17,231	19,268
1998	17,668	18,076	18,184	18,516	19,704	21,581	22,632	22,253	20,719	19,083	18,164	17,685	19,522
1999	17,508	18,112	18,500	18,948	19,839	21,460	22,593	21,979	20,496	19,258	18,233	17,570	19,541
2000	20,481	20,754	20,845	21,227	22,599	24,755	24,902	24,687	23,664	22,430	22,200	22,155	22,558
2001	20,729	20,624	20,779	21,094	22,428	24,301	25,293	24,059	22,936	21,963	21,691	21,620	22,293
2002	21,156	20,856	21,027	21,838	22,808	23,712	24,815	24,118	22,850	22,070	21,828	21,719	22,400
2003	21,363	21,060	21,448	21,815	23,049	24,239	25,001	24,230	22,445	21,727	21,480	21,239	22,425
2004	20,918	21,031	21,233	21,622	23,030	24,700	25,566	24,386	22,987	22,205	21,807	21,552	22,586
2005	21,352	21,167	21,601	21,850	23,312	24,840	25,774	24,587	23,064	22,388	21,860	21,648	22,787
2006	21,143	21,095	21,496	21,480	23,202	24,862							

Table 1.60

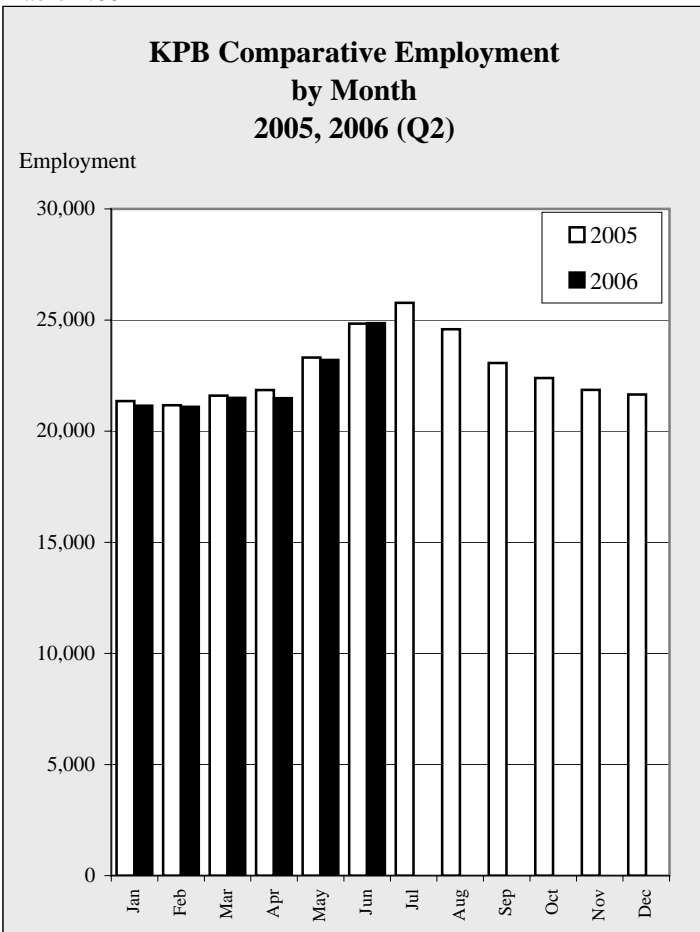

Chart 1.71

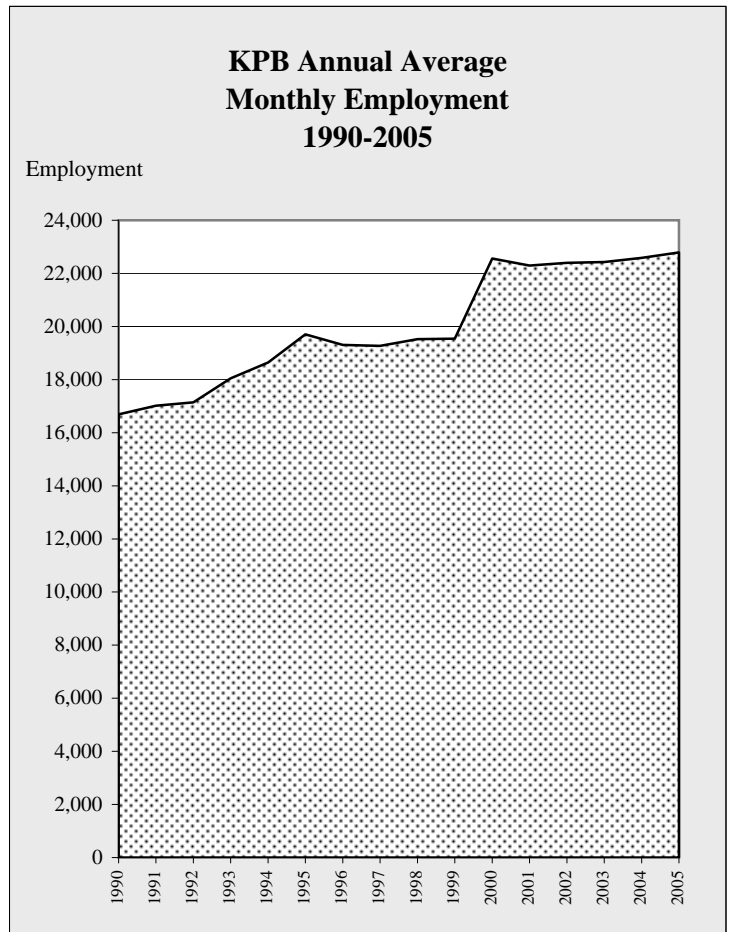

Chart 1.72

KPB Population

Census 2000

KPB population trends are determined through the decennial census conducted by the United States Census Bureau. A portion of Census 2000 data is presented in this section. Additional data is available through the U.S. Census Bureau or through the KPB CEDD office. Check out the U.S. Census Bureau website (<http://www.census.gov/>), which has two fantastic options, QuickFacts and AmericanFactFinder.

Census data is collected for two types of area, incorporated cities and Census Designated Places (CDP). Incorporated cities within the KPB include Homer, Kachemak City, Kenai, Seldovia, Seward and Soldotna. To be classified as a CDP, there are no specific boundaries but rather geographic features such as rivers, roads, or ridges. Certain characteristics must be present, including:

- * A sense of community;
- * A population of 25 or more; and
- * It must have been recognized as possibly fitting the criteria four years prior to the census as planning began.

The Census Bureau considers an incorporated city with a population greater than 2,500 to be urban, of which there are four in the KPB: Homer, Kenai, Seward and Soldotna. As of Census 2000 Kenai is ranked 6th largest in Alaska, Homer ranks 14th, and Soldotna is the 15th largest Alaskan city.

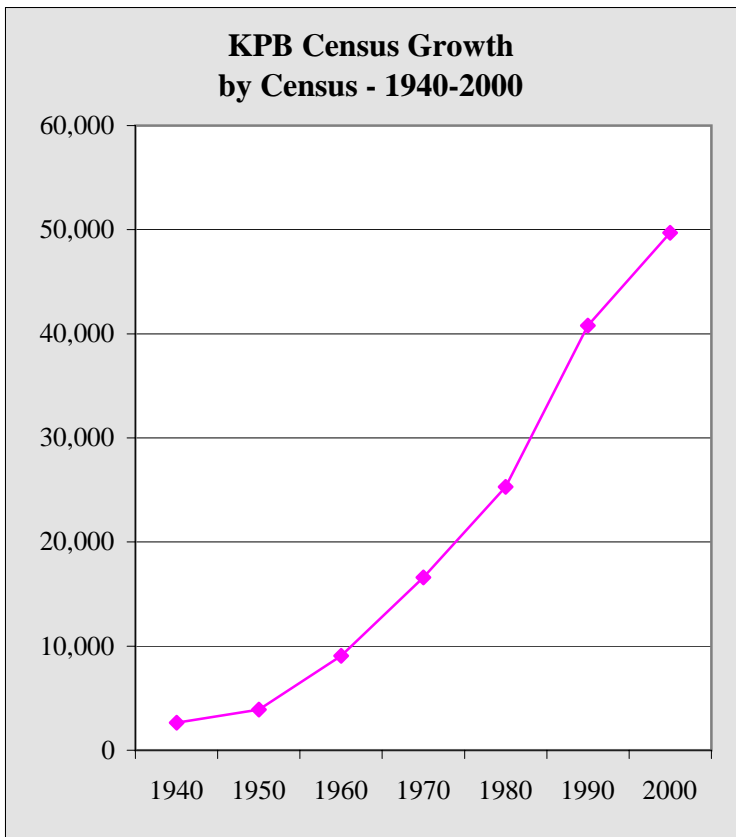

Chart 1.73

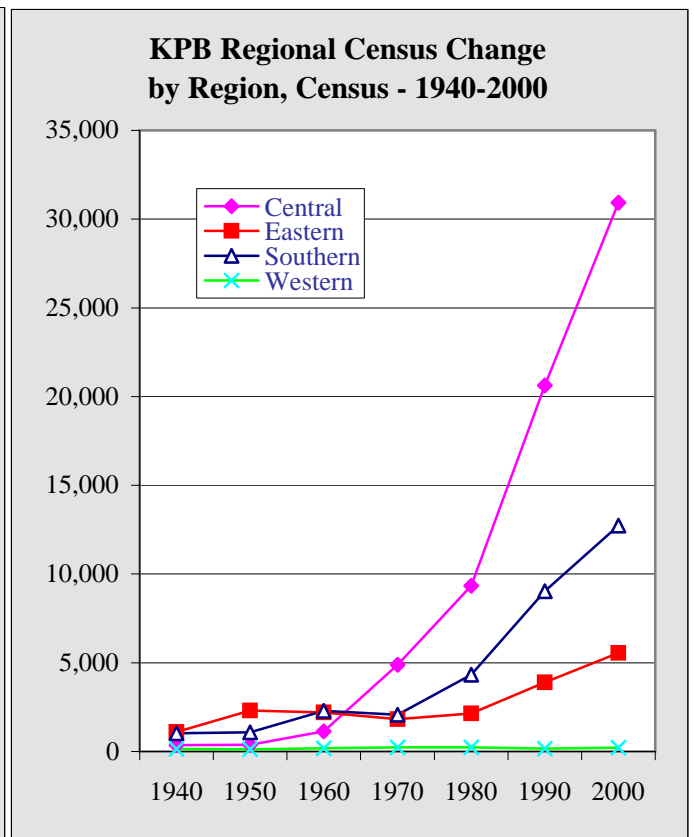

Chart 1.74

KPB Population

KPB Census by Community/CDP - 1940-2000									
KPB Community	Region	1940	1950	1960	1970	1980	1990	2000	
Anchor Point	S	20	65	171	102	226	866	1,845	
Bear Creek	E	0	0	0	0	0	580	1,748	
Beluga	W	New CDP - Census 2000							32
Clam Gulch	C	0	0	0	47	50	79	173	
Cohoe	C	0	0	122	0	0	508	1,168	
Cooper Landing	E	0	60	88	31	116	243	369	
Crown Point	E	0	0	0	0	0	62	75	
Diamond Ridge	S	New						1,802	
Fox River	S	0	0	0	0	0	382	616	
Fritz Creek	S	0	0	0	27	302	1,426	1,603	
Funny River	C	New CDP - Census 2000							636
Halibut Cove	S	0	0	25	44	47	78	35	
Happy Valley	S	0	0	0	0	0	309	489	
Homer	S	325	307	1,247	1,083	2,209	3,660	3,946	
Hope	E	71	63	44	51	103	161	137	
Jakolof Bay	S	Deleted - Census 2000					36	28	Deleted
Kachemak	S	0	0	0	76	403	365	431	
Kalifornsky	C	0	0	0	0	92	285	5,846	
Kasilof	C	62	62	89	71	201	383	471	
Kenai	C	303	321	778	3,533	4,324	6,327	6,942	
Lowell Point	E	New CDP - Census 2000							92
Miller Landing	S	New CDP - Census 2000							74
Moose Pass	E	84	70	136	53	76	81	206	
Nanwalek	S	48	75	78	58	124	158	177	
Nikiski	C		0	0	0	1,109	2,743	4,327	
Nikolaevsk	S	0	0	0	0	0	371	345	
Nililchik	S	132	97	169	134	341	456	772	
Port Graham	S	93	92	139	107	161	166	171	
Primrose	E	0	0	0	0	0	63	93	
Ridgeway	C	0	0	0	0	0	2,018	1,932	
Salamatof	C	0	0	0	0	334	999	954	
Seldovia Village	S						143	144	
Seldovia City	S	410	437	460	437	479	316	286	
Seward	E	949	2,114	1,891	1,587	1,843	2,699	2,830	
Soldotna	C	0	0	32	1,202	2,320	3,482	3,759	
Sterling	C	0	0	115	30	919	3,802	4,705	
Sunrise	C	New CDP - Census 2000							18
Tyonek	W	136	132	187	232	239	154	193	
Remainder of census area	E		946	3,282	7,681	16,116	7,409	249	
Kenai Peninsula Borough		2,633	4,831	9,053	16,586	25,282	40,486	49,691	

Table 1.61

KPB Population

KPB CDP's Population Estimates - 2000 - 2005							
KPB Community	2000 Census	June 1 Estimate (Subject to Annual Revision)					Annual Change
		2001	2002	2003	2004	2005	
Anchor Point	1,845	1,809	1,784	1,812	1,792	1,767	-1.4%
Bear Creek	1,748	1,836	1,832	1,835	1,897	1,884	-0.7%
Beluga	32	24	25	27	26	21	-19.2%
Clam Gulch	173	168	173	176	164	172	4.9%
Cohoe	1,168	1,175	1,209	1,206	1,312	1,262	-3.8%
Cooper Landing	369	391	372	358	351	344	-2.0%
Crown Point	75	89	88	78	89	82	-7.9%
Diamond Ridge*	1,802	1,812	404	306	761	732	-3.8%
Fox River	616	594	574	572	587	612	4.3%
Fritz Creek	1,603	1,662	1,735	1,744	1,732	1,775	2.5%
Funny River	636	624	688	707	727	747	2.8%
Halibut Cove	35	29	28	27	26	23	-11.5%
Happy Valley	489	505	521	505	525	477	-9.1%
Homer*	3,946	4,065	5,527	5,865	5,332	5,435	1.9%
Hope	137	145	152	161	165	139	-15.8%
Kachemak	431	426	433	478	475	457	-3.8%
Kalifornsky	5,846	6,011	6,153	6,249	6,617	6,748	2.0%
Kasilof	471	451	504	568	473	526	11.2%
Kenai	6,942	6,870	7,071	7,123	6,809	6,777	-0.5%
Lowell Point	92	96	108	89	74	96	29.7%
Miller Landing*	74	70					
Moose Pass	206	206	217	221	220	218	-0.9%
Nanwalek	177	184	219	214	203	222	9.4%
Nikiski	4,327	4,362	4,360	4,356	4,279	4,187	-2.2%
Nikolaevsk	345	345	331	312	306	304	-0.7%
Ninilchik	772	758	760	774	783	785	0.3%
Port Graham	171	178	174	165	153	134	-12.4%
Primrose	93	98	92	86	90	84	-6.7%
Ridgeway	1,932	1,961	1,963	2,022	2,047	2,062	0.7%
Salamatof	954	894	897	904	900	906	0.7%
Seldovia**	430	435	450	431	426	430	0.9%
Seldovia City**	286	285	288	279	263	287	9.1%
Seldovia Village**	144	150	166	155	170	148	-12.9%
Seward	2,830	2,759	2,754	2,745	2,540	2,606	2.6%
Soldotna	3,759	3,791	3,856	3,992	3,767	3,869	2.7%
Sterling	4,705	4,753	4,771	4,880	4,940	4,983	0.9%
Sunrise	18	16	14	15	19	24	26.3%
Tyonek	193	161	181	192	184	199	8.2%
Remainder							
Kenai/Cook Inlet		229	188	190	181	164	-9.4%
Remainder Seward census sub area		23	13	13	8	15	87.5%
Remainder of KPB	249						
Kenai Peninsula	49,691	50,005	50,621	51,398	50,980	51,268	0.6%

Table 1.62

* - Homer annexation included all of Miller Landing CDP and part of Diamond Ridge CDP. Annexation was effective March 20, 2002.

** - Seldovia City plus Seldovia Village is not equal to the Seldovia CDP.

Note - All Estimates since 2000 have been revised by the State of Alaska Department of Labor and Workforce Development.

KPB Population



Chart 1.75

This page intentionally left blank.

Homer Sales

Homer 2nd Quarter GROSS Sales by Industry - 2001-2006 - in \$							
	2001	2002	2003	2004	2005	2006	Annual Change
Ag, Forestry, Fishing	221,357	250,389	420,146	430,095	522,694	477,184	-8.7%
Mining	1,844	3,836	0	104	15,410	0	-100.0%
Construction	6,727,125	7,437,731	11,071,038	5,685,550	11,488,754	8,838,688	-23.1%
Manufacturing	1,455,193	1,790,421	1,899,935	1,807,647	1,590,559	1,513,787	-4.8%
Trans, Comm, Pub Util	8,926,617	10,982,097	9,778,534	11,805,442	12,467,876	13,998,538	12.3%
Wholesale	5,204,028	5,360,132	6,092,813	6,421,737	7,134,397	7,219,747	1.2%
Retail	20,975,149	24,997,009	27,557,784	30,021,416	32,401,744	33,004,350	1.9%
Finance, Ins, Real Estate	1,982,111	2,046,589	2,547,744	2,619,310	2,780,519	2,897,476	4.2%
Services	11,364,051	15,806,975	15,919,950	16,960,913	17,801,236	18,263,881	2.6%
Government	0	0	0	0	0	0	NA
Total	56,857,475	68,675,179	75,287,944	75,752,214	86,203,189	86,213,651	0.01%
Annual Change		20.8%	9.6%	0.6%	13.8%	0.01%	

Table 2.1

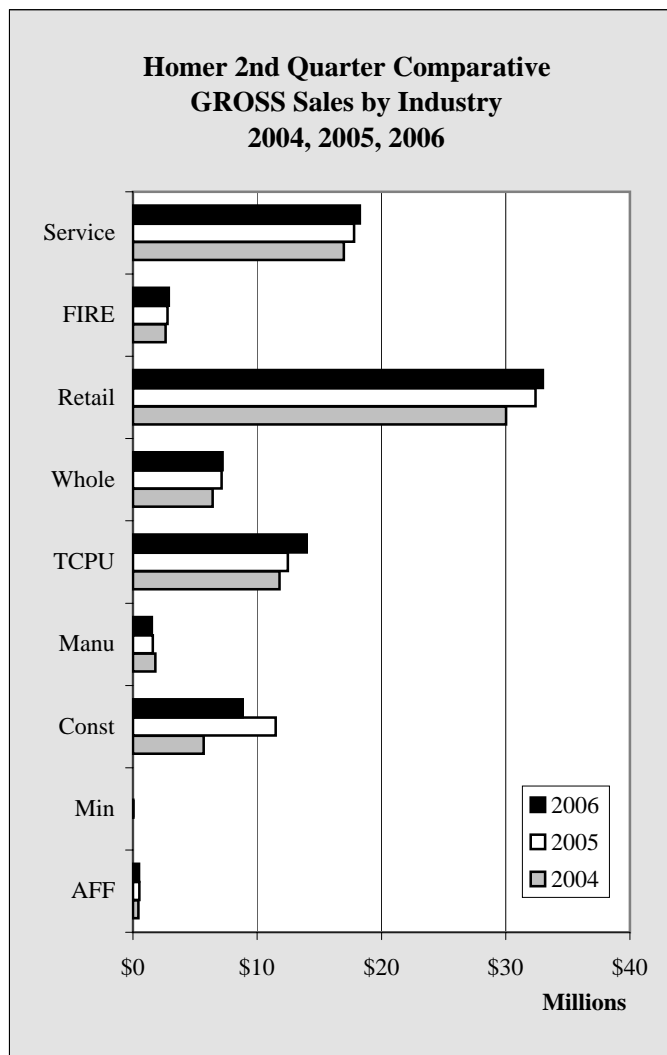

Chart 2.1

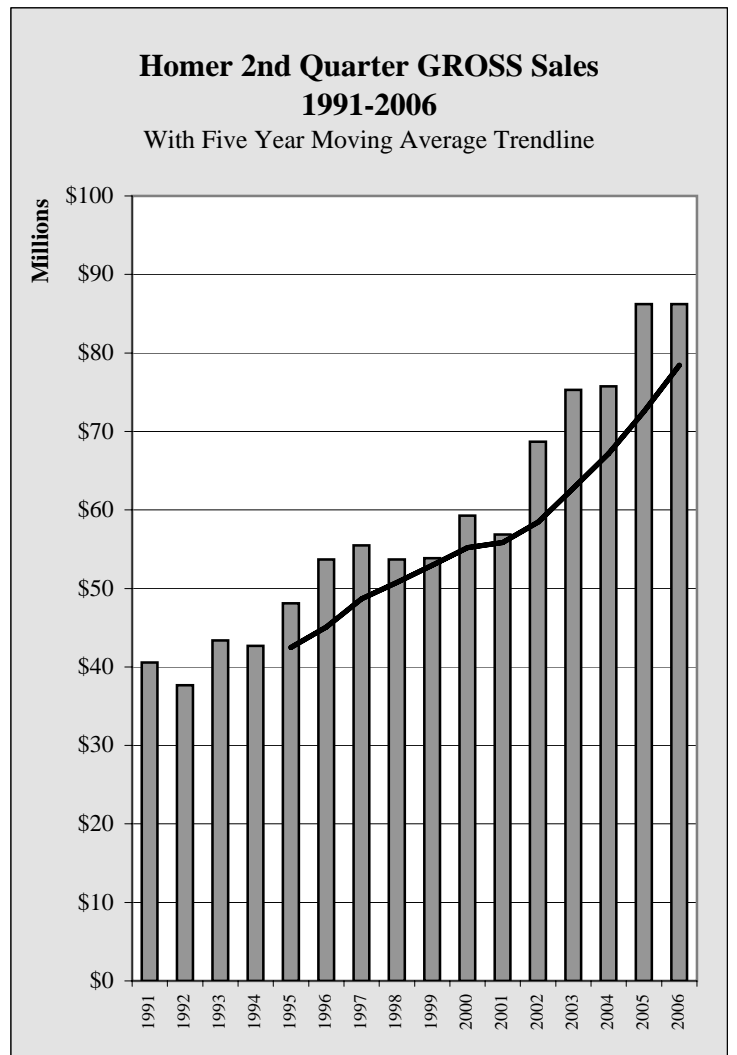

Chart 2.2

Annexation of an area increasing the size of Homer by approximately 28% was effective April 1, 2002.

Homer Sales

Homer 2nd Quarter TAXABLE Sales by Industry - 2001-2006 - in \$							
	2001	2002	2003	2004	2005	2006	Annual Change
Ag, Forestry, Fishing	146,035	166,982	212,539	247,630	240,199	272,470	13.4%
Mining	1,549	1,955	0	104	0	0	NA
Construction	217,384	266,994	312,650	319,319	281,839	304,863	8.2%
Manufacturing	528,377	557,095	532,466	608,034	514,206	482,703	-6.1%
Trans, Comm, Pub Util	2,581,062	2,873,043	3,212,975	3,248,197	3,274,454	3,383,581	3.3%
Wholesale	2,538,512	2,518,226	2,966,252	3,320,836	3,362,819	3,212,546	-4.5%
Retail	15,861,254	18,247,283	19,762,887	21,267,878	22,712,669	23,350,161	2.8%
Finance, Ins, Real Estate	923,819	1,005,737	1,062,609	1,153,322	1,094,646	1,126,777	2.9%
Services	7,393,485	8,633,608	8,976,090	9,483,204	10,012,514	9,160,512	-8.5%
Government	0	0	0	0	0	0	NA
Total	30,191,477	34,270,923	37,038,468	39,648,524	41,493,346	41,293,613	-0.5%
Annual Change		13.5%	8.1%	7.0%	4.7%	-0.5%	

Table 2.2

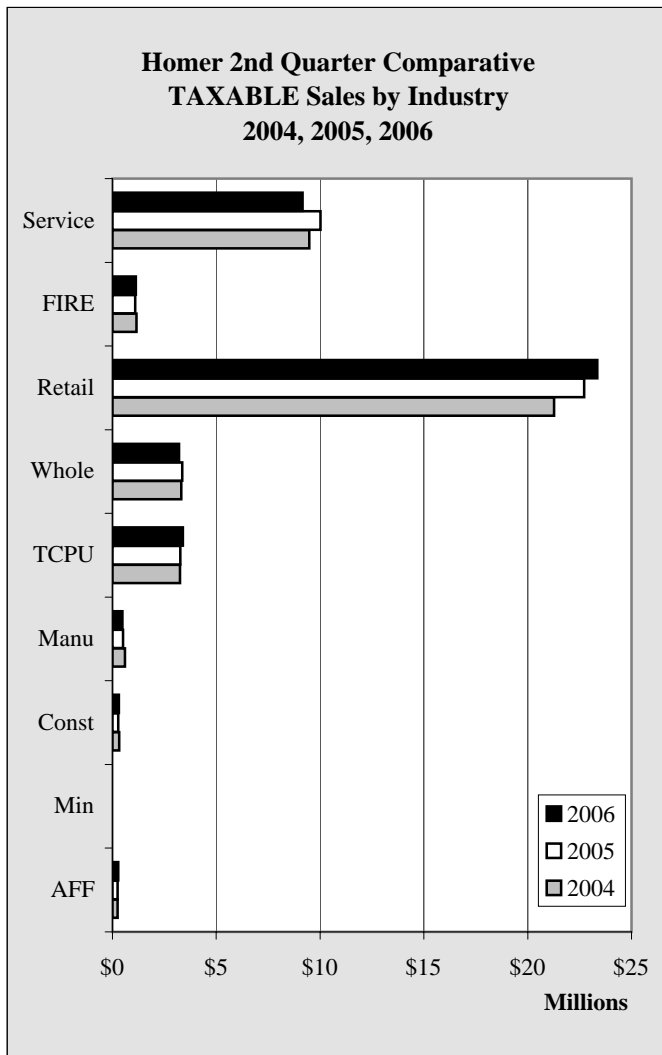

Chart 2.3

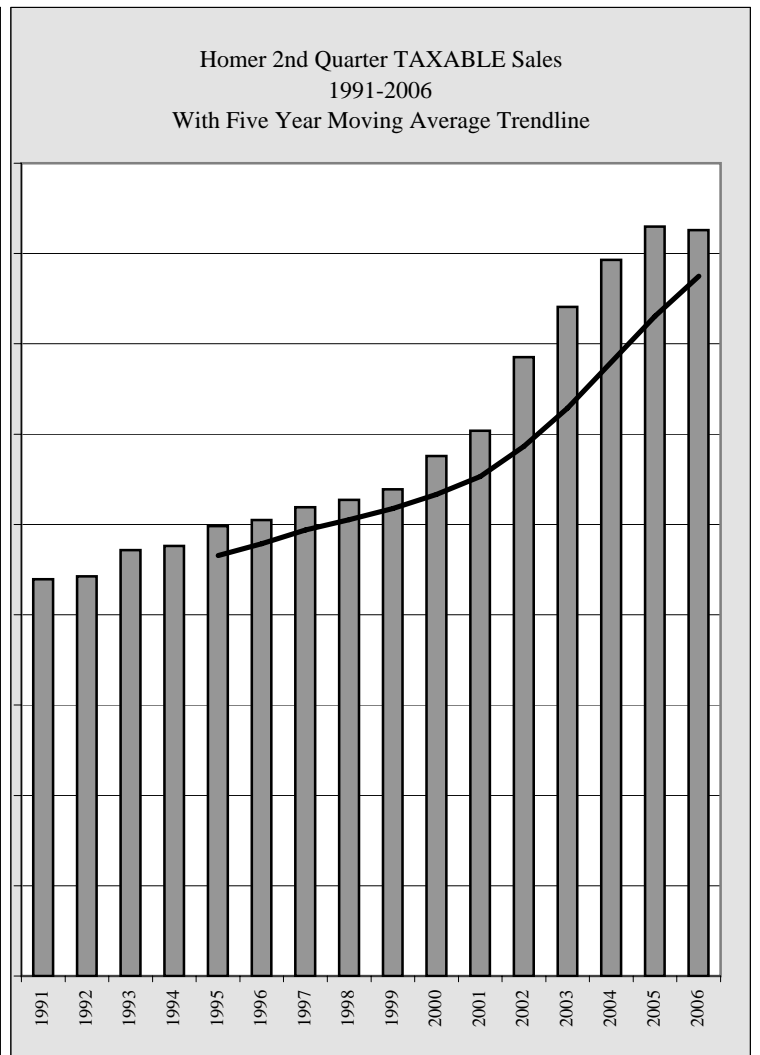

Chart 2.4

Annexation of an area increasing the size of Homer by approximately 28% was effective April 1, 2002.

Homer Sales

Homer YTD 6/30 GROSS Sales by Industry - 2001-2006 - in \$							
	2001	2002	2003	2004	2005	2006	Annual Change
Ag, Forestry, Fishing	381,823	385,101	669,479	659,447	794,971	741,822	-6.7%
Mining	10,981	5,199	0	360	15,410	0	-100.0%
Construction	14,850,565	15,872,008	20,866,561	10,011,515	16,752,905	14,817,168	-11.6%
Manufacturing	2,780,586	3,044,255	3,217,571	2,923,790	2,355,081	2,581,323	9.6%
Trans, Comm, Pub Util	17,319,824	20,766,385	19,239,191	21,782,890	23,329,333	27,165,719	16.4%
Wholesale	8,704,682	8,718,142	10,137,408	10,543,909	11,614,849	12,368,449	6.5%
Retail	33,901,273	38,764,881	44,666,489	48,248,833	52,200,881	53,627,429	2.7%
Finance, Ins, Real Estate	3,387,314	3,574,314	4,537,669	4,866,668	4,857,978	5,014,948	3.2%
Services	16,365,405	21,814,547	23,181,852	24,855,994	26,186,126	26,094,788	-0.3%
Government	0	0	0	394	0	0	NA
Total	97,702,453	112,944,832	126,516,220	123,893,800	138,107,534	142,411,646	3.1%
Annual Change		15.6%	12.0%	-2.1%	11.5%	3.1%	

Table 2.3

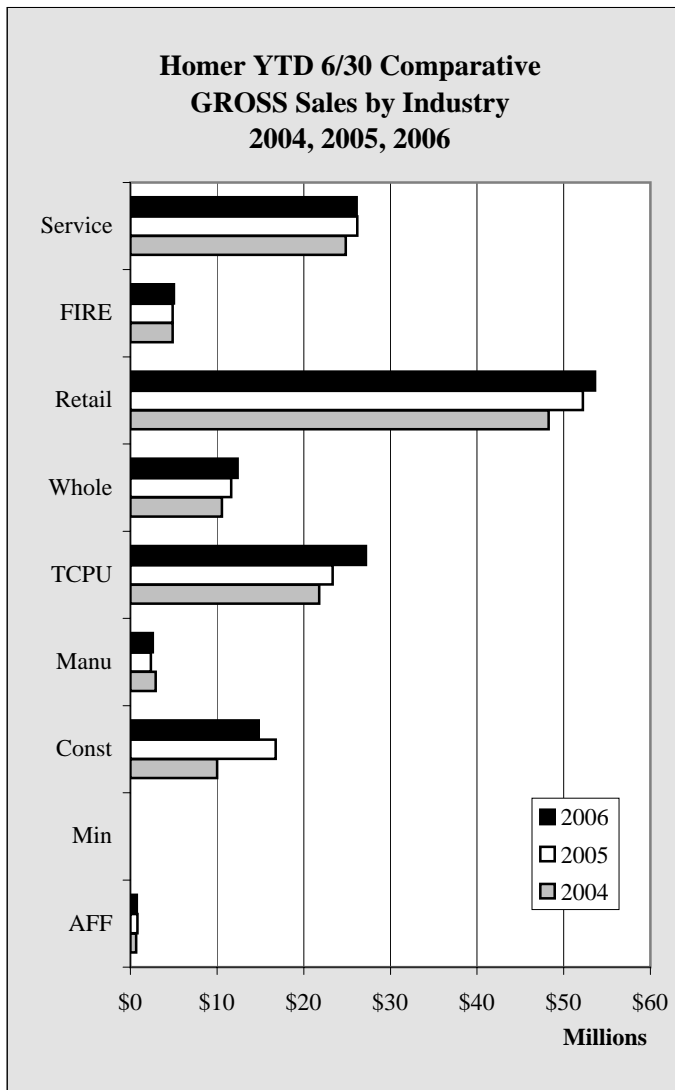

Chart 2.5

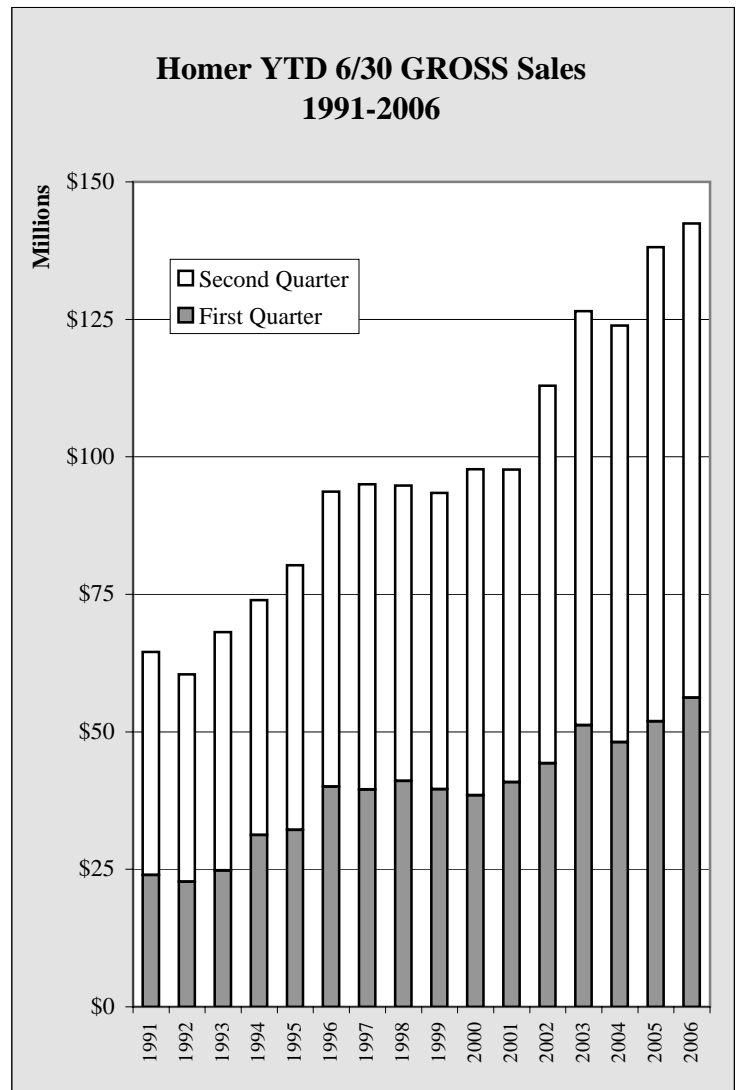

Chart 2.6

Annexation of an area increasing the size of Homer by approximately 28% was effective April 1, 2002.

Homer Sales

Homer YTD 6/30 TAXABLE Sales by Industry - 2001-2006 - in \$							
	2001	2002	2003	2004	2005	2006	Annual Change
Ag, Forestry, Fishing	254,324	284,255	348,273	405,587	429,481	464,706	8.2%
Mining	3,189	2,665	0	104	0	0	NA
Construction	396,176	506,128	555,996	596,204	524,586	583,447	11.2%
Manufacturing	854,252	820,347	809,992	913,385	736,292	712,075	-3.3%
Trans, Comm, Pub Util	4,710,712	5,098,165	6,103,590	6,054,703	6,095,061	6,553,264	7.5%
Wholesale	4,230,347	4,180,681	4,977,060	5,555,215	5,548,735	5,841,197	5.3%
Retail	25,410,773	28,347,971	31,761,592	34,246,636	36,201,713	37,503,416	3.6%
Finance, Ins, Real Estate	1,615,853	1,774,305	1,962,755	2,043,875	1,949,231	1,977,072	1.4%
Services	10,481,055	11,956,364	12,975,492	13,657,341	14,344,190	13,500,089	-5.9%
Government	0	0	0	394	0	0	NA
Total	47,956,681	52,970,881	59,494,750	63,473,444	65,829,289	67,135,266	2.0%
Annual Change		10.5%	12.3%	6.7%	3.7%	2.0%	

Table 2.4

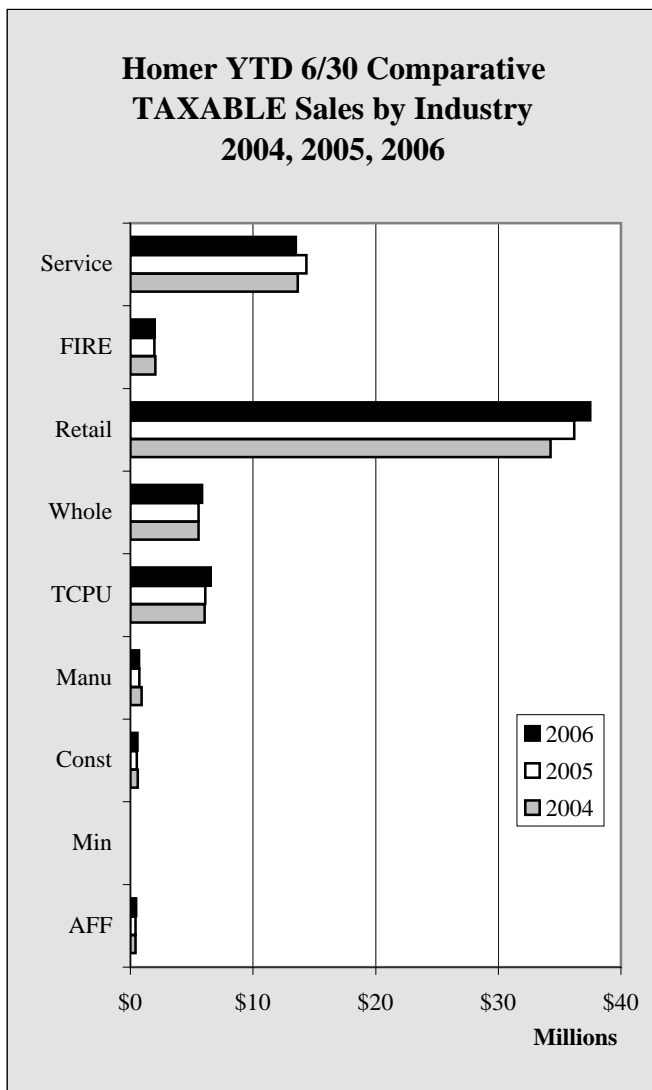

Chart 2.7

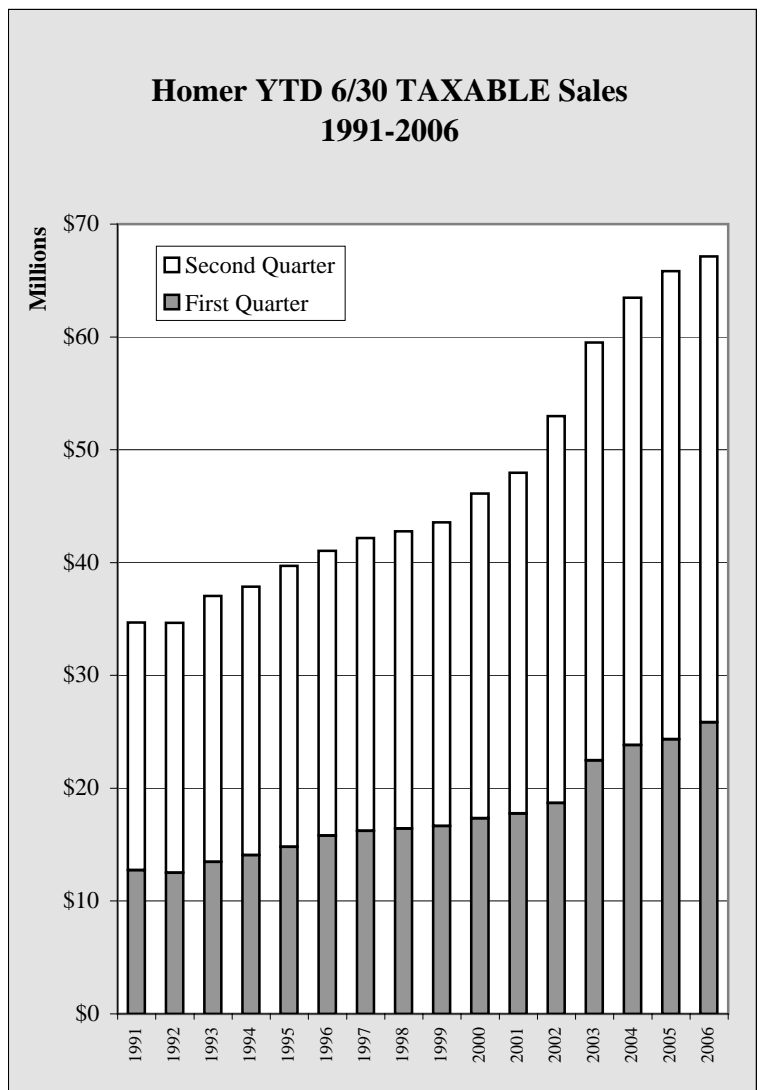

Chart 2.8

Annexation of an area increasing the size of Homer by approximately 28% was effective April 1, 2002.

Homer Sales

Homer Annual GROSS Sales by Industry - 2000-2005 - in \$							
	2000	2001	2002	2003	2004	2005	Annual Change
Ag, Forestry, Fishing	1,763,891	931,926	1,013,352	1,592,413	1,520,013	1,721,692	13.3%
Mining	24,864	15,819	8,582	1,283	151,171	16,254	-89.2%
Construction	42,378,954	40,149,696	45,854,890	41,984,440	32,449,476	37,987,966	17.1%
Manufacturing	6,761,789	6,482,895	6,590,594	6,755,907	5,657,729	5,848,168	3.4%
Trans, Comm, Pub Util	34,493,682	40,495,596	42,137,752	39,996,686	47,283,230	49,608,057	4.9%
Wholesale	16,999,389	18,602,483	19,915,750	22,075,685	27,077,381	30,251,310	11.7%
Retail	71,465,479	75,795,576	88,239,711	97,820,663	105,665,150	112,540,362	6.5%
Finance, Ins, Real Estate	6,682,678	7,544,432	8,453,334	9,936,484	11,521,431	10,969,870	-4.8%
Services	35,410,998	39,685,084	51,026,719	53,908,145	59,120,041	61,254,365	3.6%
Government	0	0	0	263	394	0	-100.0%
Total	215,981,724	229,703,507	263,240,684	274,071,969	290,446,016	310,198,044	6.8%
Annual Change		6.4%	14.6%	4.1%	6.0%	6.8%	

Table 2.5

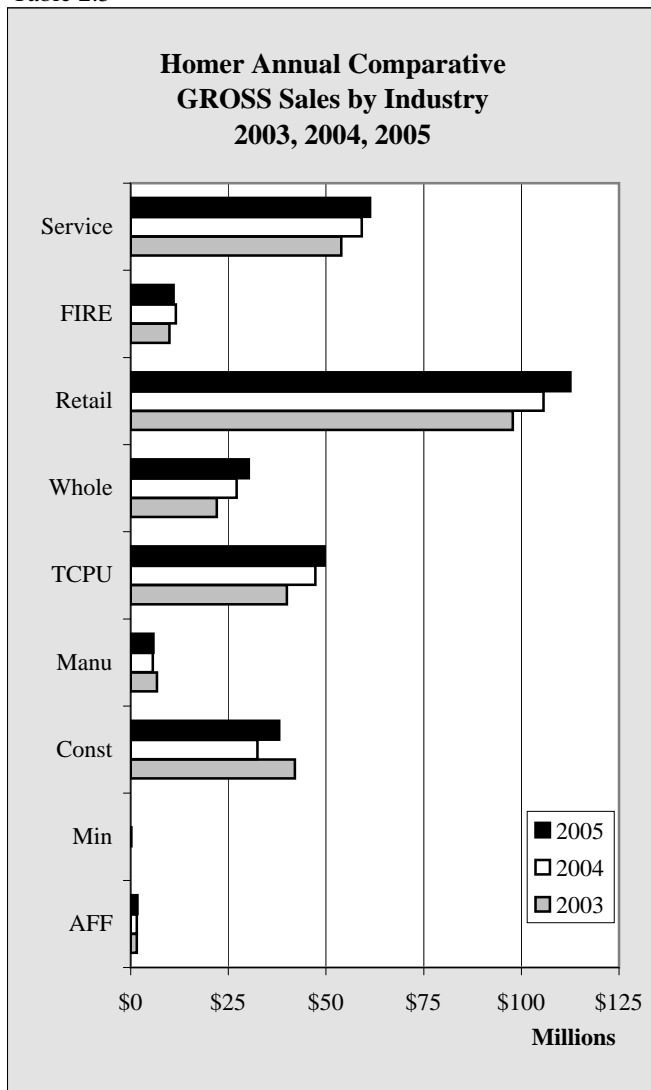

Chart 2.9

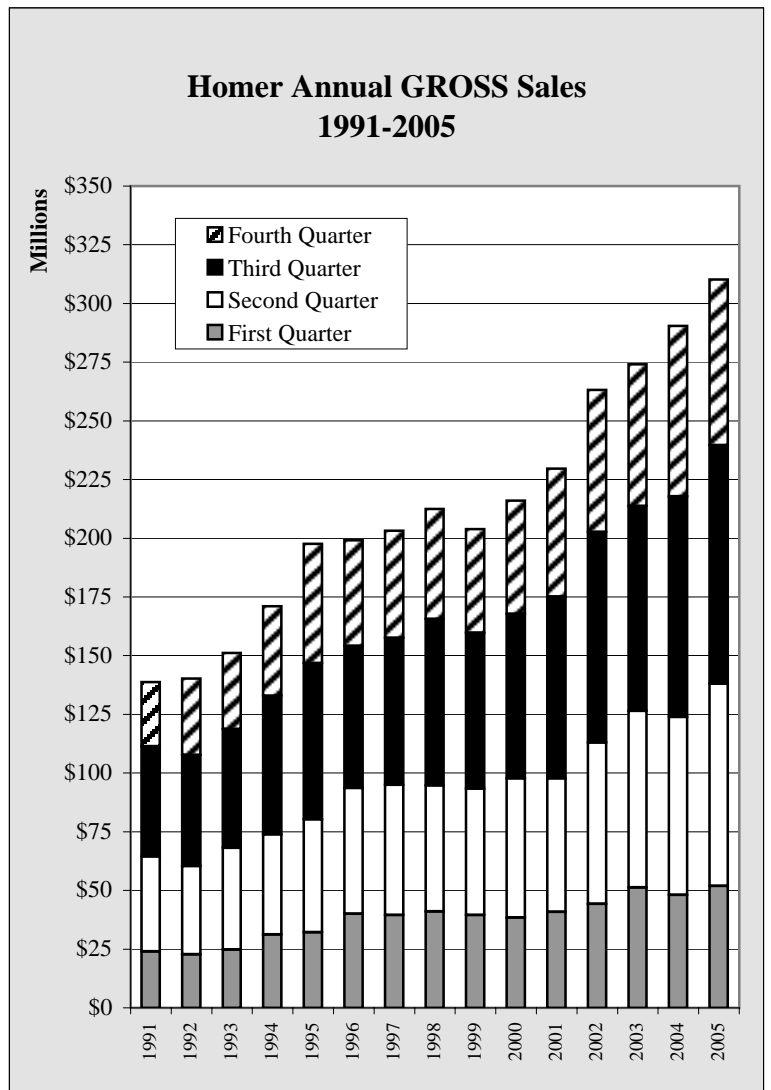

Chart 2.10

Annexation of an area increasing the size of Homer by approximately 28% was effective April 1, 2002.

Homer Sales

Homer Annual TAXABLE Sales by Industry - 2000-2005 - in \$							
	2000	2001	2002	2003	2004	2005	Annual Change
Ag, Forestry, Fishing	519,595	577,360	641,294	773,421	912,356	940,493	3.1%
Mining	1,104	5,993	2,665	347	104	0	-100.0%
Construction	891,188	940,211	1,130,715	1,208,909	1,182,169	1,207,021	2.1%
Manufacturing	2,045,894	1,769,534	1,822,345	1,848,166	1,857,314	1,630,975	-12.2%
Trans, Comm, Pub Util	10,110,454	10,200,922	11,698,087	12,717,059	12,827,427	13,020,545	1.5%
Wholesale	8,633,107	8,953,325	8,876,648	10,611,085	11,951,881	12,256,480	2.5%
Retail	53,206,860	56,027,806	63,864,887	69,823,667	74,183,011	78,433,489	5.7%
Finance, Ins, Real Estate	3,147,793	3,460,712	3,890,685	4,074,657	4,455,978	4,276,531	-4.0%
Services	24,634,121	25,375,676	29,365,222	30,669,809	32,622,727	33,938,827	4.0%
Government	0	0	0	263	394	0	-100.0%
Total	103,190,116	107,311,539	121,292,548	131,727,383	139,993,361	145,704,361	4.1%
Annual Change		4.0%	13.0%	8.6%	6.3%	4.1%	

Table 2.6

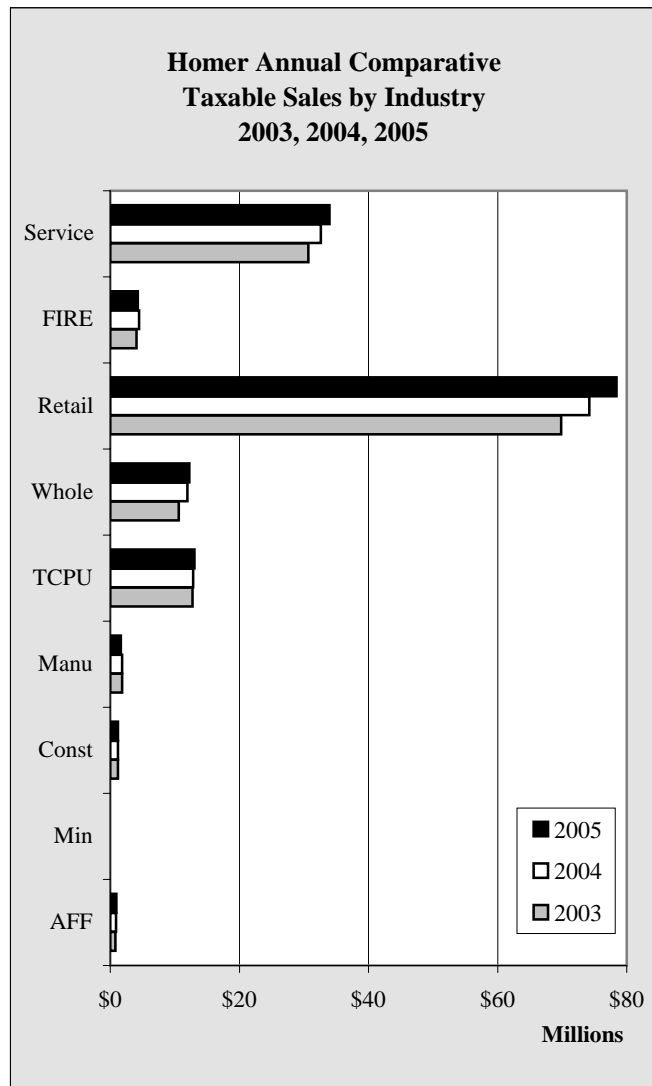

Chart 2.11

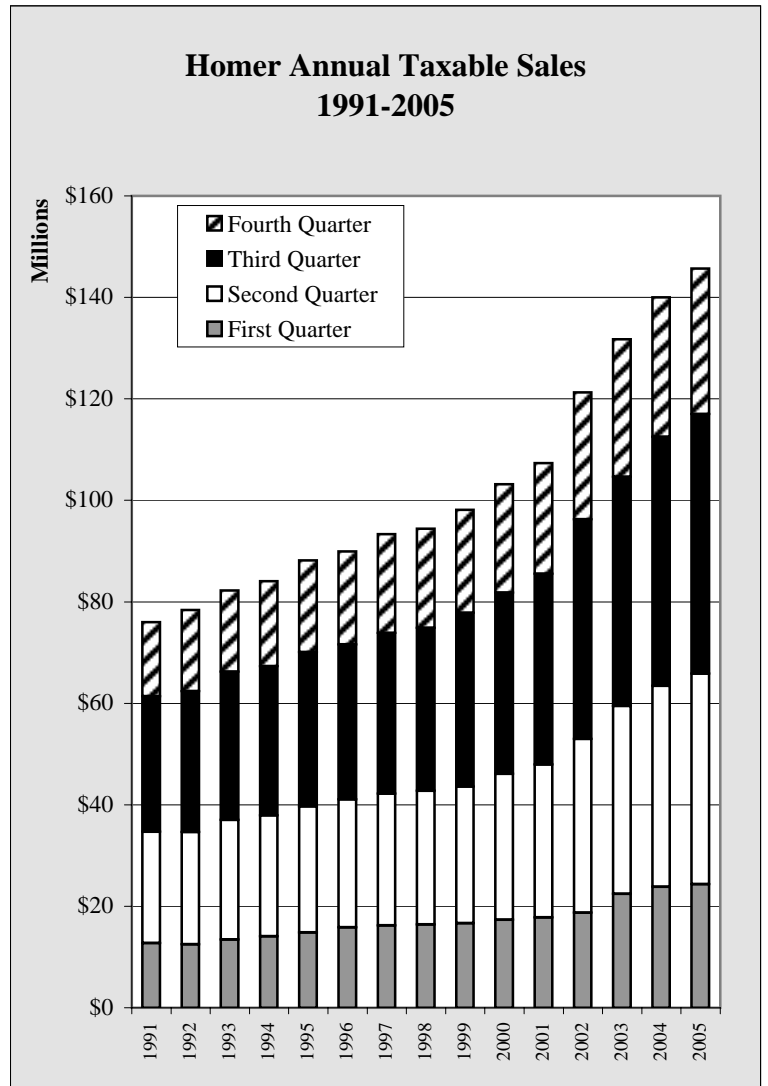

Chart 2.12

Annexation of an area increasing the size of Homer by approximately 28% was effective April 1, 2002.

Homer Sales

Homer GROSS Sales by Industry by Quarter - 2003-2006 - in \$					
	1st Quarter	2nd Quarter	3rd Quarter	4th Quarter	Total
2003					
Ag, Forestry, Fishing	249,333	420,146	485,712	437,222	1,592,413
Mining	0	0	448	835	1,283
Construction	9,795,523	11,071,038	11,629,038	9,488,841	41,984,440
Manufacturing	1,317,636	1,899,935	2,019,280	1,519,056	6,755,907
Trans, Comm, Pub Util	9,460,657	9,778,534	11,335,988	9,421,507	39,996,686
Wholesale	4,044,595	6,092,813	6,629,440	5,308,837	22,075,685
Retail	17,108,705	27,557,784	31,205,896	21,948,278	97,820,663
Finance, Ins, Real Estate	1,989,925	2,547,744	2,825,493	2,573,322	9,936,484
Services	7,261,902	15,919,950	21,095,550	9,630,743	53,908,145
Government	0	0	0	263	263
Total	51,228,276	75,287,944	87,226,845	60,328,904	274,071,969
2004					
Ag, Forestry, Fishing	229,352	430,095	512,372	348,194	1,520,013
Mining	256	104	695	150,116	151,171
Construction	4,325,965	5,685,550	9,736,168	12,701,793	32,449,476
Manufacturing	1,116,143	1,807,647	1,752,124	981,815	5,657,729
Trans, Comm, Pub Util	9,977,448	11,805,442	13,967,425	11,532,915	47,283,230
Wholesale	4,122,172	6,421,737	7,325,763	9,207,709	27,077,381
Retail	18,227,417	30,021,416	34,477,697	22,938,620	105,665,150
Finance, Ins, Real Estate	2,247,358	2,619,310	3,341,741	3,313,022	11,521,431
Services	7,895,081	16,960,913	22,821,410	11,442,637	59,120,041
Government	394	0	0	0	394
Total	48,141,586	75,752,214	93,935,395	72,616,821	290,446,016
2005					
Ag, Forestry, Fishing	272,277	522,694	604,181	322,540	1,721,692
Mining	0	15,410	582	262	16,254
Construction	5,264,151	11,488,754	12,574,485	8,660,576	37,987,966
Manufacturing	764,522	1,590,559	1,916,955	1,576,132	5,848,168
Trans, Comm, Pub Util	10,861,457	12,467,876	14,430,164	11,848,560	49,608,057
Wholesale	4,480,452	7,134,397	8,285,268	10,351,193	30,251,310
Retail	19,799,137	32,401,744	36,249,484	24,089,997	112,540,362
Finance, Ins, Real Estate	2,077,459	2,780,519	3,307,180	2,804,712	10,969,870
Services	8,384,890	17,801,236	24,126,674	10,941,565	61,254,365
Government	0	0	0	0	0
Total	51,904,345	86,203,189	101,494,973	70,595,537	310,198,044
2006					
				Year to Date	
Ag, Forestry, Fishing	264,638	477,184			741,822
Mining	0	0			0
Construction	5,978,480	8,838,688			14,817,168
Manufacturing	1,067,536	1,513,787			2,581,323
Trans, Comm, Pub Util	13,167,181	13,998,538			27,165,719
Wholesale	5,148,702	7,219,747			12,368,449
Retail	20,623,079	33,004,350			53,627,429
Finance, Ins, Real Estate	2,117,472	2,897,476			5,014,948
Services	7,830,907	18,263,881			26,094,788
Government	0	0			0
Total	56,197,995	86,213,651	0	0	142,411,646

Table 2.7

Homer Sales

Homer TAXABLE Sales by Industry by Quarter - 2003-2006 - in \$					
	1st Quarter	2nd Quarter	3rd Quarter	4th Quarter	Total
2003					
Ag, Forestry, Fishing	135,734	212,539	250,473	174,675	773,421
Mining	0	0	0	347	347
Construction	243,346	312,650	335,295	317,618	1,208,909
Manufacturing	277,526	532,466	618,081	420,093	1,848,166
Trans, Comm, Pub Util	2,890,615	3,212,975	3,752,532	2,860,937	12,717,059
Wholesale	2,010,808	2,966,252	3,370,701	2,263,324	10,611,085
Retail	11,998,705	19,762,887	22,642,061	15,420,014	69,823,667
Finance, Ins, Real Estate	900,146	1,062,609	1,146,791	965,111	4,074,657
Services	3,999,402	8,976,090	13,011,152	4,683,165	30,669,809
Government	0	0	0	263	263
Total	22,456,282	37,038,468	45,127,086	27,105,547	131,727,383
2004					
Ag, Forestry, Fishing	157,957	247,630	305,982	200,787	912,356
Mining	0	104	0	0	104
Construction	276,885	319,319	300,979	284,986	1,182,169
Manufacturing	305,351	608,034	632,048	311,881	1,857,314
Trans, Comm, Pub Util	2,806,506	3,248,197	3,909,932	2,862,792	12,827,427
Wholesale	2,234,379	3,320,836	3,998,096	2,398,570	11,951,881
Retail	12,978,758	21,267,878	24,233,534	15,702,841	74,183,011
Finance, Ins, Real Estate	890,553	1,153,322	1,453,205	958,898	4,455,978
Services	4,174,137	9,483,204	14,193,603	4,771,783	32,622,727
Government	394	0	0	0	394
Total	23,824,920	39,648,524	49,027,379	27,492,538	139,993,361
2005					
Ag, Forestry, Fishing	189,282	240,199	289,599	221,413	940,493
Mining	0	0	0	0	0
Construction	242,747	281,839	364,714	317,721	1,207,021
Manufacturing	222,086	514,206	587,478	307,205	1,630,975
Trans, Comm, Pub Util	2,820,607	3,274,454	3,921,717	3,003,767	13,020,545
Wholesale	2,185,916	3,362,819	4,141,476	2,566,269	12,256,480
Retail	13,489,044	22,712,669	25,670,364	16,561,412	78,433,489
Finance, Ins, Real Estate	854,585	1,094,646	1,391,223	936,077	4,276,531
Services	4,331,676	10,012,514	14,824,061	4,770,576	33,938,827
Government	0	0	0	0	0
Total	24,335,943	41,493,346	51,190,632	28,684,440	145,704,361
2006					
				Year to Date	
Ag, Forestry, Fishing	192,236	272,470			464,706
Mining	0	0			0
Construction	278,584	304,863			583,447
Manufacturing	229,372	482,703			712,075
Trans, Comm, Pub Util	3,169,683	3,383,581			6,553,264
Wholesale	2,628,651	3,212,546			5,841,197
Retail	14,153,255	23,350,161			37,503,416
Finance, Ins, Real Estate	850,295	1,126,777			1,977,072
Services	4,339,577	9,160,512			13,500,089
Government	0	0			0
Total	25,841,653	41,293,613	0	0	67,135,266

Table 2.8

Homer Construction

Homer 2nd Quarter Permit VALUES by Type - 2001-2006 - in \$							
	2001	2002	2003	2004	2005	2006	Annual Change
Residential New	2,093,800	1,308,460	3,811,480	2,495,400	3,072,000	4,250,100	38.3%
Residential Alter/Add	306,440	205,400	239,060	205,730	451,000	287,000	-36.4%
Commercial New	1,485,800	1,000,000	3,535,720	4,700,518	7,473,000	2,310,000	-69.1%
Commercial Alter/Add	216,000	14,349	343,240	32,063	250,000	620,000	148.0%
Total	4,102,040	2,528,209	7,929,500	7,433,711	11,246,000	7,467,100	-33.6%
Annual Change		-38.4%	213.6%	-6.3%	51.3%	-33.6%	

Table 2.9

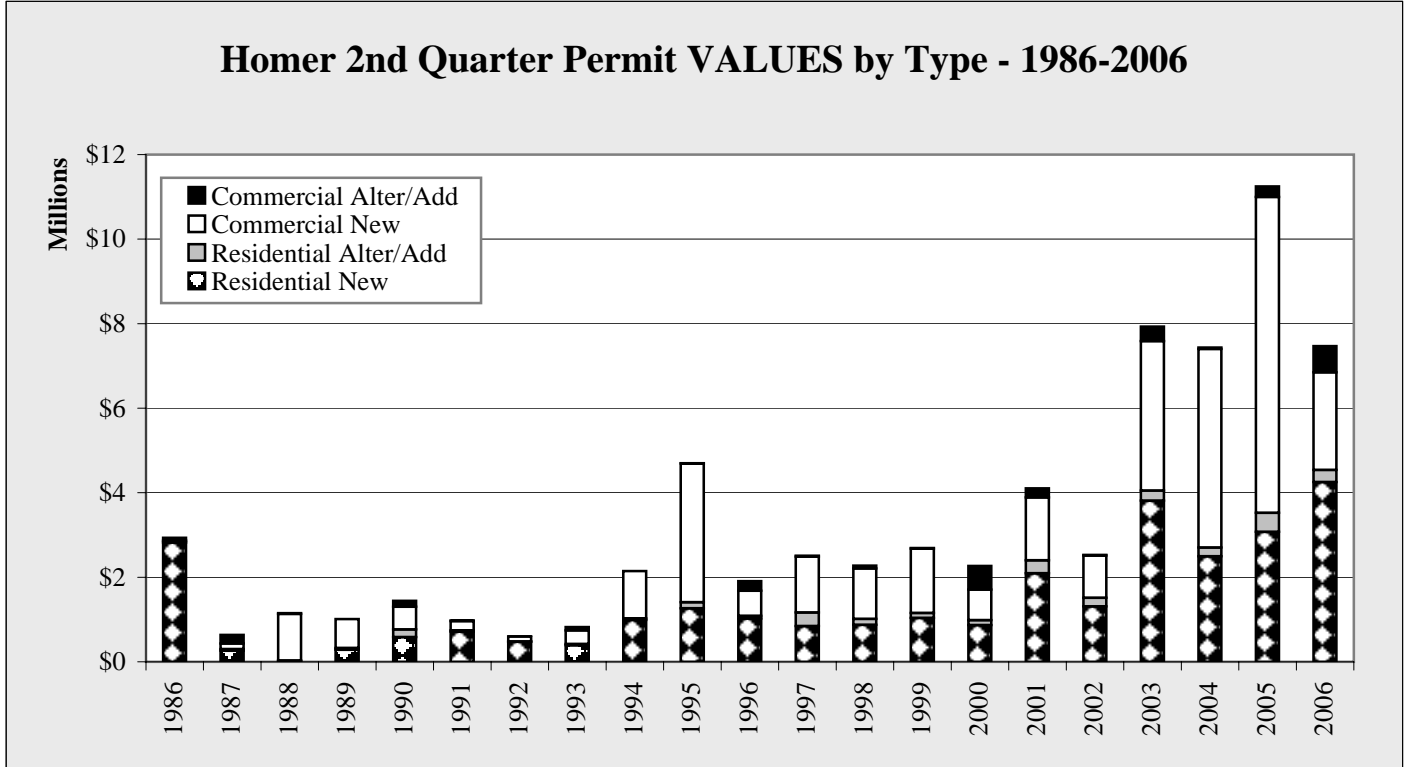

Chart 2.13

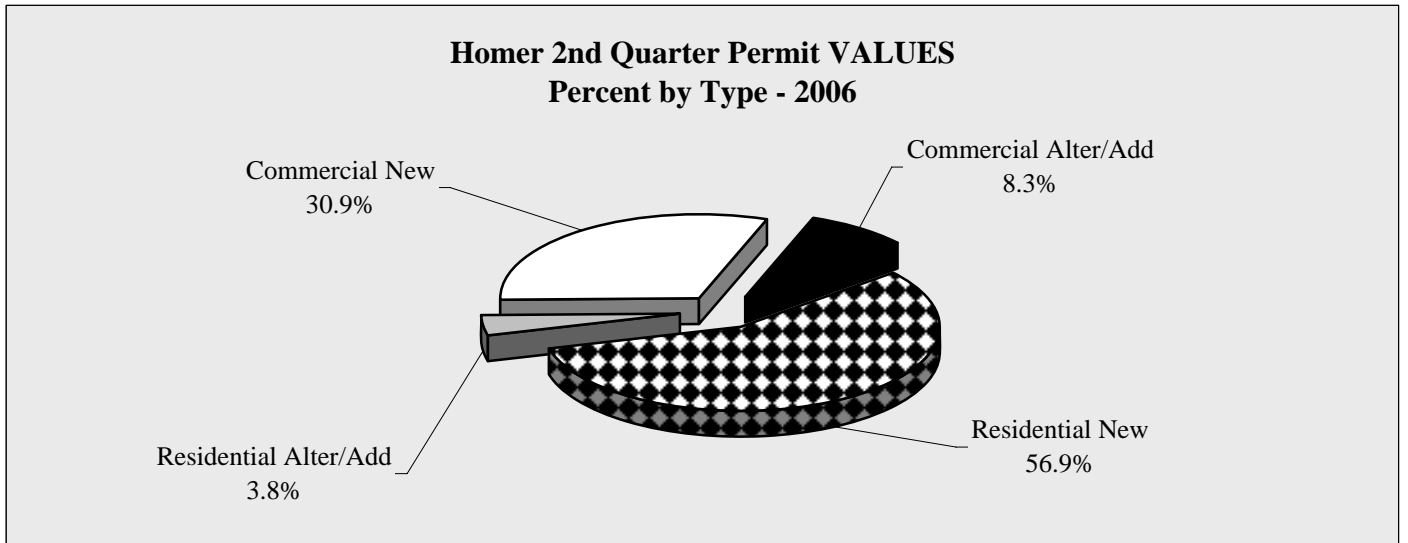

Chart 2.14

Homer Construction

Homer 2nd Quarter Permit VOLUME by Type - 2001-2006							
	2001	2002	2003	2004	2005	2006	Annual Change
Residential New	14	9	17	15	22	23	4.5%
Residential Alter/Add	12	5	6	5	13	8	-38.5%
Commercial New	3	1	7	5	10	5	-50.0%
Commercial Alter/Add	5	2	4	1	2	3	50.0%
Total	34	17	34	26	47	39	-17.0%
Annual Change		-50.0%	100.0%	-23.5%	80.8%	-17.0%	

Table 2.10

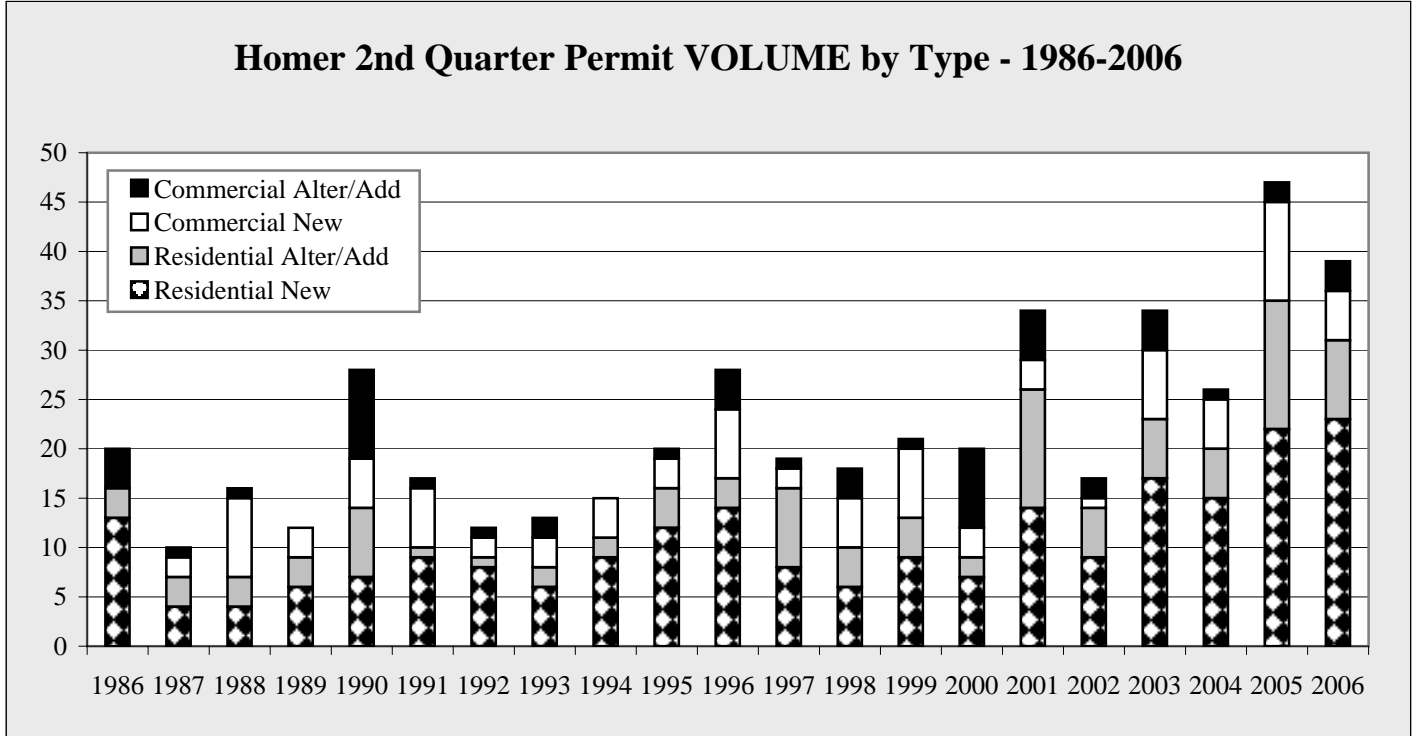

Chart 2.15

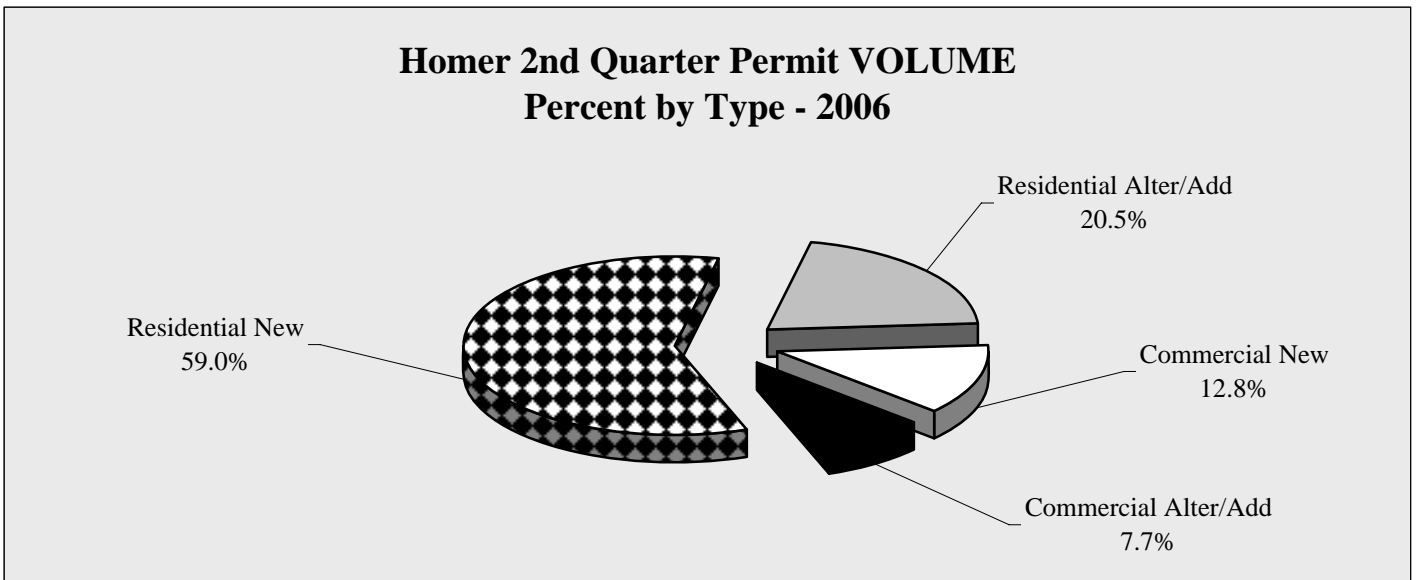

Chart 2.16

Homer Construction

Homer YTD 6/30 Permit VALUES by Type - 2001-2006 - in \$

	2001	2002	2003	2004	2005	2006	Annual Change
Residential New	2,393,800	2,200,220	4,791,280	5,092,900	4,766,400	5,895,100	23.7%
Residential Alter/Add	366,440	214,360	471,600	407,250	452,500	287,000	-36.6%
Commercial New	1,770,800	1,000,000	3,535,720	5,615,518	7,581,000	2,936,000	-61.3%
Commercial Alter/Add	261,000	42,349	465,240	32,063	1,552,000	1,620,000	4.4%
Total	4,792,040	3,456,929	9,263,840	11,147,731	14,351,900	10,738,100	-25.2%
Annual Change		-27.9%	168.0%	20.3%	28.7%	-25.2%	

Table 2.11

Homer YTD 6/30 Permit VALUES by Type - 1986-2006

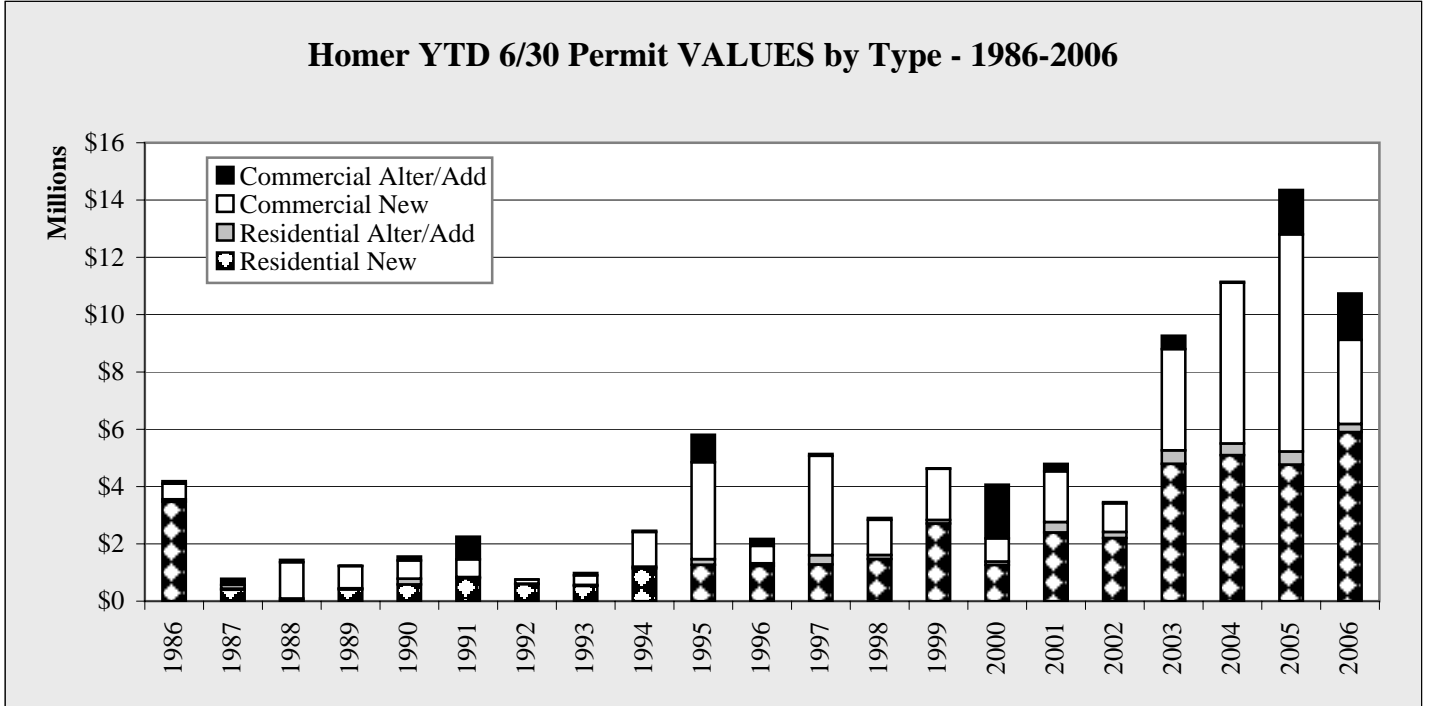

Chart 2.17

**Homer YTD 6/30 Permit VALUES
Percent by Type - 2006**

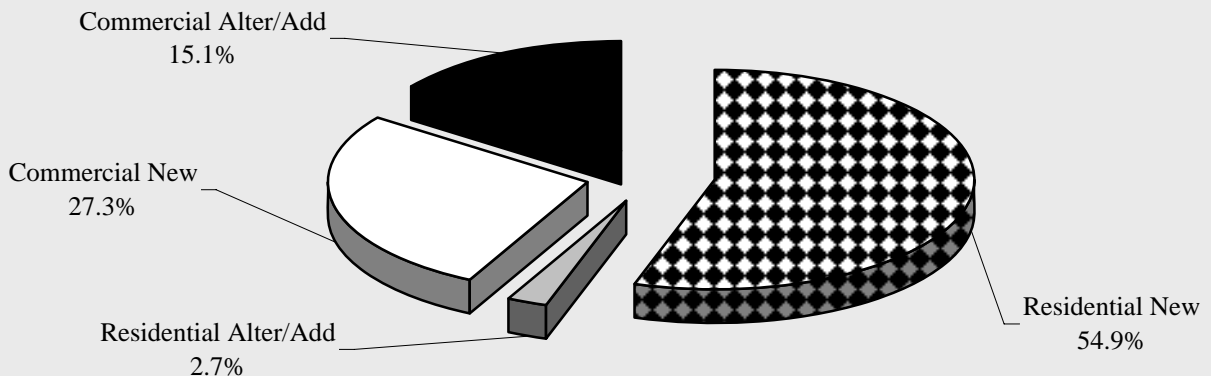

Chart 2.18

Homer Construction

Homer YTD 6/30 Permit VOLUME by Type - 2001-2006							
	2001	2002	2003	2004	2005	2006	Annual Change
Residential New	17	17	23	26	32	32	0.0%
Residential Alter/Add	13	6	14	7	14	8	-42.9%
Commercial New	5	1	7	7	12	8	-33.3%
Commercial Alter/Add	6	3	8	2	7	5	-28.6%
Total	41	27	52	42	65	53	-18.5%
Annual Change		-34.1%	92.6%	-19.2%	54.8%	-18.5%	

Table 2.12

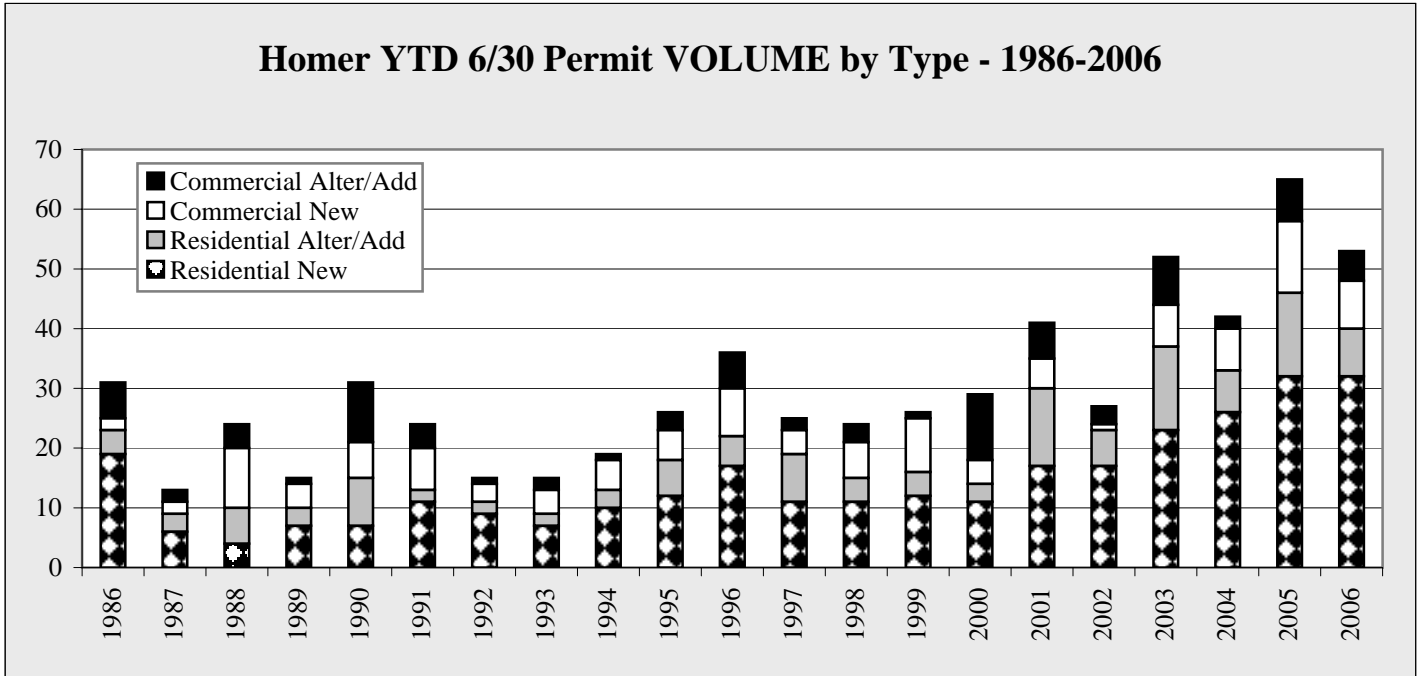

Chart 2.19

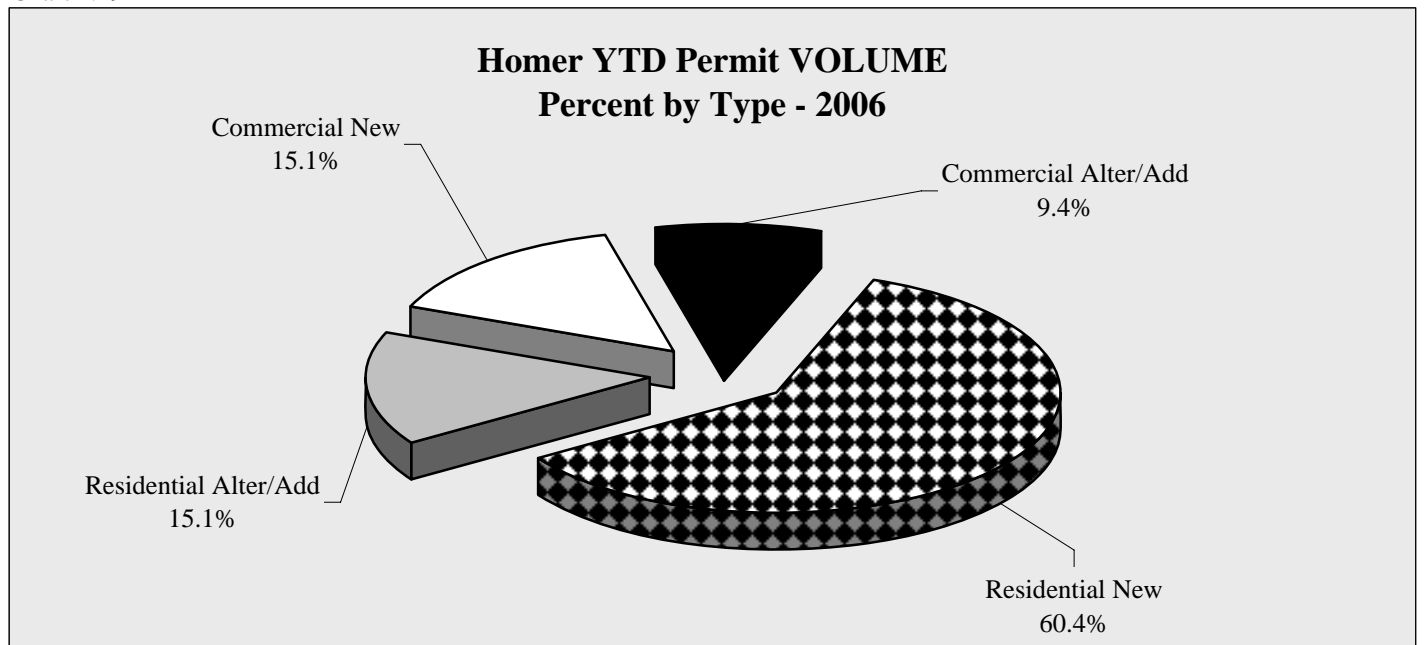

Chart 2.20

Homer Construction

Homer Annual Permit VALUES by Type by Quarter - 2000-2006 - in \$					
	1st Quarter	2nd Quarter	3rd Quarter	4th Quarter	Total
2000					
Residential - New	392,600	867,440	1,025,000	326,000	2,611,040
Residential - Add/Alter	5,500	115,000	109,560	0	230,060
Commercial - New	85,000	725,480	805,000	48,000	1,663,480
Commercial - Add/Alter	1,315,000	558,000	207,410	543,982	2,624,392
TOTAL	1,798,100	2,265,920	2,146,970	917,982	7,128,972
2001					
Residential - New	300,000	2,093,800	1,161,680	492,300	4,047,780
Residential - Add/Alter	60,000	306,440	122,720	120,000	609,160
Commercial - New	285,000	1,485,800	340,000	300,000	2,410,800
Commercial - Add/Alter	45,000	216,000	1,371,950	11,100,000	12,732,950
TOTAL	690,000	4,102,040	2,996,350	12,012,300	19,800,690
2002					
Residential - New	891,760	1,308,460	1,466,300	560,200	4,226,720
Residential - Add/Alter	8,960	205,400	217,940	104,320	536,620
Commercial - New	0	1,000,000	3,912,740	78,000	4,990,740
Commercial - Add/Alter	28,000	14,349	180,350	72,000	294,699
TOTAL	928,720	2,528,209	5,777,330	814,520	10,048,779
2003					
Residential - New	979,800	3,811,480	2,106,275	1,222,900	8,120,455
Residential - Add/Alter	232,540	239,060	285,000	50,000	806,600
Commercial - New	0	3,535,720	628,800	1,600,000	5,764,520
Commercial - Add/Alter	122,000	343,240	0	170,000	635,240
TOTAL	1,334,340	7,929,500	3,020,075	3,042,900	15,326,815
2004					
Residential - New	2,597,500	2,495,400	1,225,600	377,000	6,695,500
Residential - Add/Alter	201,520	205,730	851,300	437,000	1,695,550
Commercial - New	915,000	4,700,518	6,225,000	2,560,000	14,400,518
Commercial - Add/Alter	0	32,063	1,230,000	17,000	1,279,063
TOTAL	3,714,020	7,433,711	9,531,900	3,391,000	24,070,631
2005					
Residential - New	1,694,400	3,072,000	1,548,500	895,000	7,209,900
Residential - Add/Alter	1,500	451,000	374,000	80,000	906,500
Commercial - New	108,000	7,473,000	2,240,000	1,975,000	11,796,000
Commercial - Add/Alter	1,302,000	250,000	120,000	27,000	1,699,000
TOTAL	3,105,900	11,246,000	4,282,500	2,977,000	21,611,400
2006					
					Year to Date
Residential - New	1,645,000	4,250,100			5,895,100
Residential - Add/Alter	0	287,000			287,000
Commercial - New	626,000	2,310,000			2,936,000
Commercial - Add/Alter	1,000,000	620,000			1,620,000
TOTAL	3,271,000	7,467,100			10,738,100

Table 2.13

Homer Construction

Homer Annual Permit VOLUME by Type by Quarter - 2000-2006					
	1st Quarter	2nd Quarter	3rd Quarter	4th Quarter	Total
2000					
Residential - New	4	7	8	4	23
Residential - Add/Alter	1	2	5	0	8
Commercial - New	1	3	2	2	8
Commercial - Add/Alter	3	8	6	2	19
TOTAL	9	20	21	8	58
2001					
Residential - New	3	14	9	4	30
Residential - Add/Alter	1	12	4	2	19
Commercial - New	2	3	2	1	8
Commercial - Add/Alter	1	5	7	2	15
TOTAL	7	34	22	9	72
2002					
Residential - New	8	9	10	5	32
Residential - Add/Alter	1	5	8	6	20
Commercial - New	0	1	6	1	8
Commercial - Add/Alter	1	2	3	1	7
TOTAL	10	17	27	13	67
2003					
Residential - New	6	17	15	9	47
Residential - Add/Alter	8	6	3	2	19
Commercial - New	0	7	3	1	11
Commercial - Add/Alter	4	4	0	1	9
TOTAL	18	34	21	13	86
2004					
Residential - New	11	15	9	6	41
Residential - Add/Alter	2	5	21	9	37
Commercial - New	2	5	8	7	22
Commercial - Add/Alter	1	1	4	2	8
TOTAL	16	26	42	24	108
2005					
Residential - New	10	22	13	6	51
Residential - Add/Alter	1	13	9	2	25
Commercial - New	2	10	4	2	18
Commercial - Add/Alter	5	2	1	1	9
TOTAL	18	47	27	11	103
2006					
					Year to Date
Residential - New	9	23			32
Residential - Add/Alter	0	8			8
Commercial - New	3	5			8
Commercial - Add/Alter	2	3			5
TOTAL	14	39			53

Table 2.14

Kenai Sales

Kenai 2nd Quarter GROSS Sales by Industry - 2001-2006 - in \$							
	2001	2002	2003	2004	2005	2006	Annual Change
Ag, Forest, Fish	787,584	810,865	838,734	1,296,885	2,360,990	2,235,504	-5.3%
Mining	321,650	516,408	872,788	2,172,358	1,068,085	1,896,271	77.5%
Construction	5,291,031	4,294,788	6,395,590	2,705,601	6,371,616	3,815,073	-40.1%
Manufacturing	3,567,493	3,007,187	4,210,293	3,062,848	3,408,122	2,668,548	-21.7%
Trans, Comm, Pub Util	5,834,997	6,155,532	6,152,058	11,662,099	28,241,441	27,464,229	-2.8%
Wholesale	5,243,400	4,677,095	4,841,740	5,842,357	6,590,438	2,924,153	-55.6%
Retail	42,832,698	34,741,208	28,949,996	39,251,887	40,309,307	49,003,254	21.6%
Finance, Ins, Real Estate	3,513,695	3,668,160	3,326,119	3,294,005	3,223,641	3,412,012	5.8%
Services	9,281,388	10,058,048	11,847,481	11,099,322	10,894,305	12,923,253	18.6%
Government	0	0	0	0	0	0	0.0%
Total	76,673,936	67,929,291	67,434,799	80,387,362	102,467,945	106,342,297	3.8%
Annual Change		-11.4%	-0.7%	19.2%	27.5%	3.8%	

Table 3.1

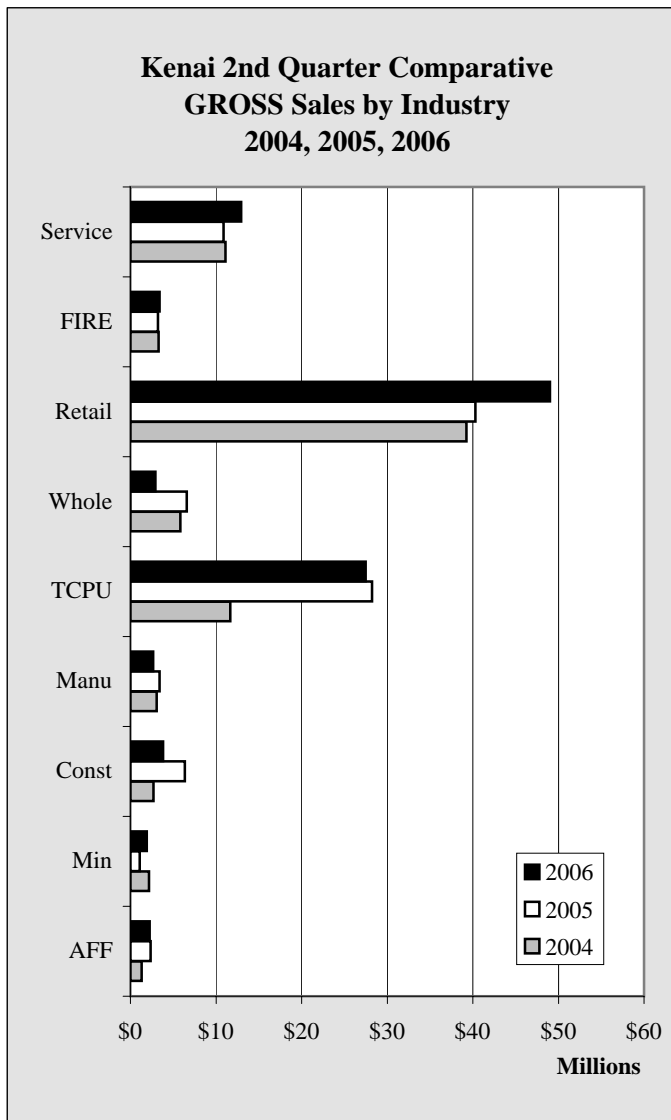

Chart 3.1

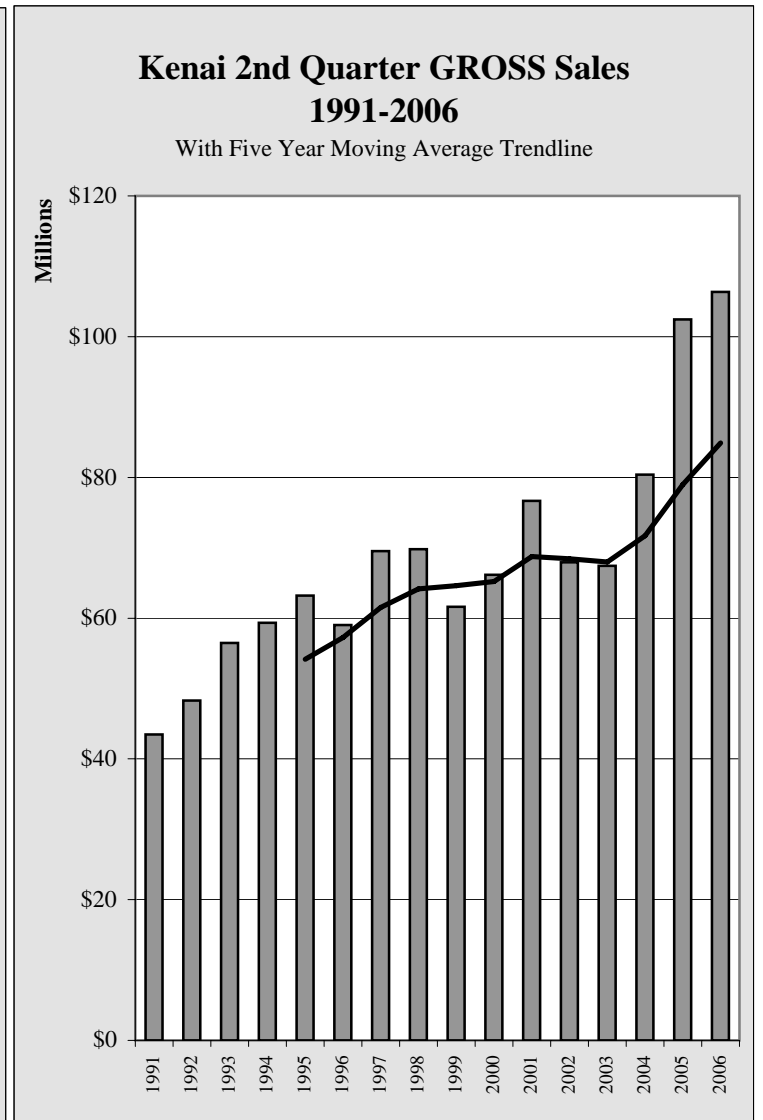

Chart 3.2

Kenai Sales

Kenai 2nd Quarter TAXABLE Sales by Industry - 2001-2006 - in \$							
	2001	2002	2003	2004	2005	2006	Annual Change
Ag, Forest, Fish	113,069	128,556	134,783	159,363	186,963	183,836	-1.7%
Mining	72,568	57,479	46,723	57,575	46,396	60,782	31.0%
Construction	268,682	272,856	294,469	291,079	316,384	225,470	-28.7%
Manufacturing	685,042	622,875	687,335	803,910	737,524	794,308	7.7%
Trans, Comm, Pub Util	3,163,762	3,794,883	4,056,076	3,467,903	3,320,405	3,731,581	12.4%
Wholesale	206,838	122,228	111,864	127,610	126,121	127,232	0.9%
Retail	23,717,206	22,876,325	18,246,087	25,145,460	26,397,732	28,674,014	8.6%
Finance, Ins, Real Estate	1,670,033	1,684,771	1,506,804	1,359,412	1,290,206	1,443,791	11.9%
Services	5,091,469	5,064,834	4,727,913	4,850,846	5,004,707	5,450,782	8.9%
Government	0	0	0	0	0	0	0.0%
Total	34,988,669	34,624,807	29,812,054	36,263,158	37,426,438	40,691,796	8.7%
Annual Change		-1.0%	-13.9%	21.6%	3.2%	8.7%	

Table 3.2

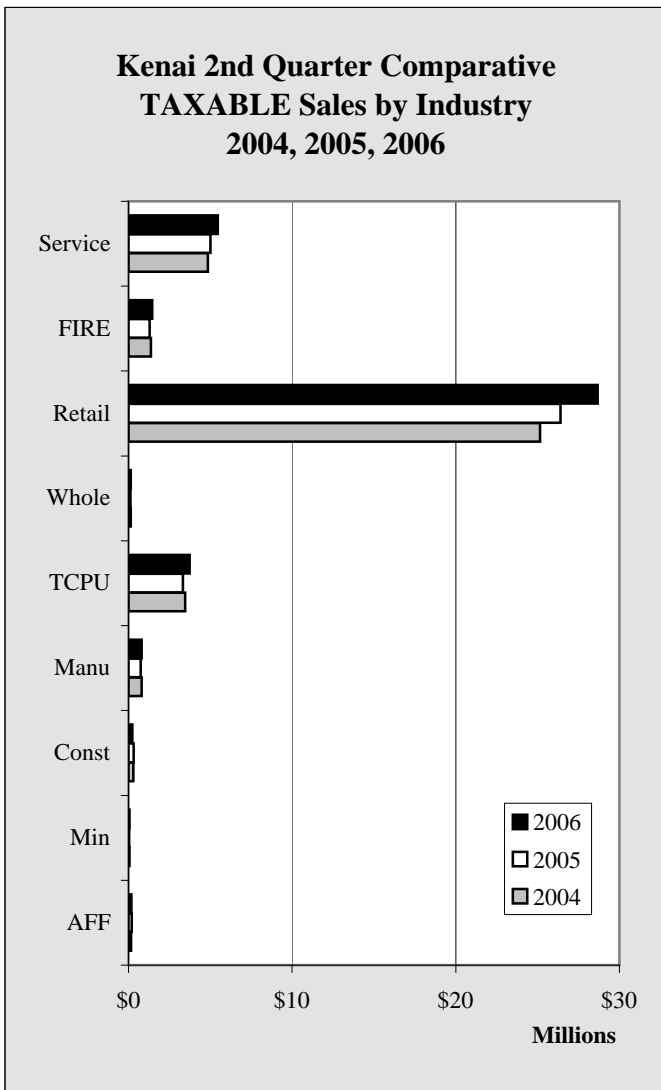

Chart 3.3

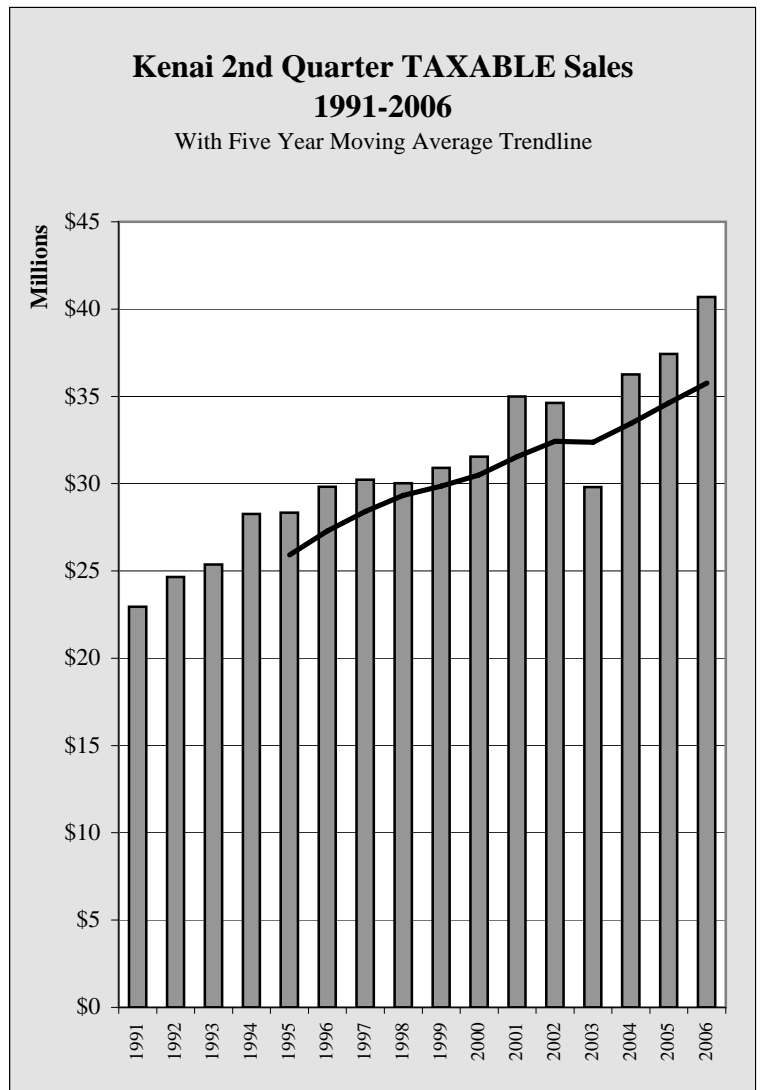

Chart 3.4

Kenai Sales

Kenai YTD 6/30 GROSS Sales by Industry - 2001-2006 - in \$							
	2001	2002	2003	2004	2005	2006	Annual Change
Ag, Forest, Fish	1,420,941	1,981,179	1,841,384	2,358,671	3,974,543	2,584,296	-35.0%
Mining	1,174,244	2,731,125	1,815,358	4,184,091	3,311,706	3,310,355	0.0%
Construction	7,205,235	8,045,604	10,487,388	4,976,142	8,341,153	5,351,627	-35.8%
Manufacturing	6,376,411	5,263,340	7,207,299	4,672,870	5,115,808	5,110,492	-0.1%
Trans, Comm, Pub Util	11,913,857	12,571,591	13,866,427	18,151,115	48,557,051	36,362,691	-25.1%
Wholesale	10,231,346	8,041,983	8,063,479	11,192,139	11,564,741	4,897,856	-57.6%
Retail	76,982,734	63,215,353	59,057,226	69,066,167	70,808,346	82,482,015	16.5%
Finance, Ins, Real Estate	6,476,043	7,133,570	6,410,719	6,212,859	5,908,078	6,434,653	8.9%
Services	17,311,411	19,541,915	20,836,376	20,656,312	20,457,719	22,823,222	11.6%
Government	0	0	0	0	0	0	NA
Total	139,092,222	128,525,660	129,585,656	141,470,366	178,039,145	169,357,207	-4.9%
Annual Change		-7.6%	0.8%	9.2%	25.8%	-4.9%	

Table 3.3

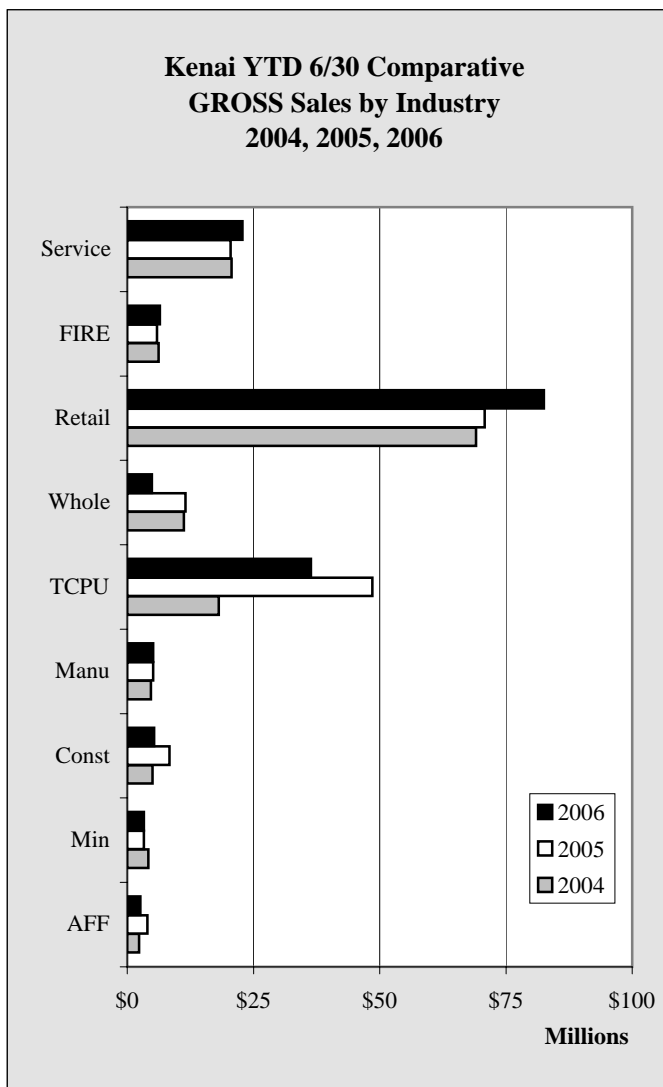

Chart 3.5

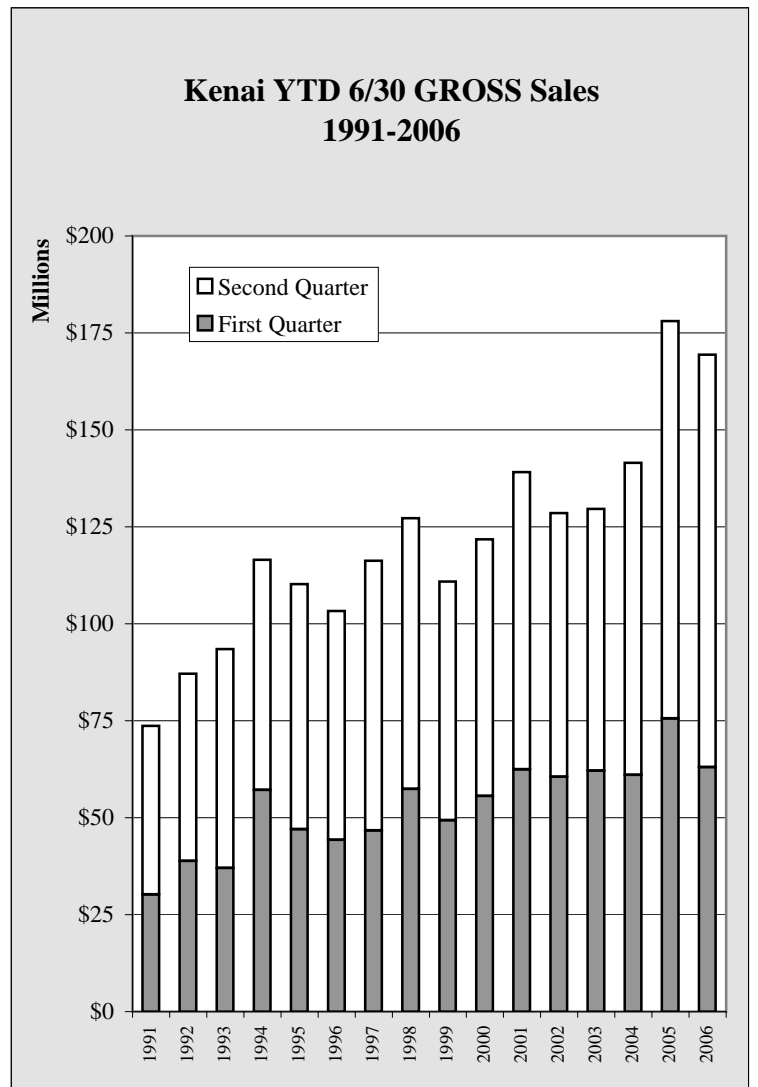

Chart 3.6

Kenai Sales

Kenai YTD 6/30 TAXABLE Sales by Industry - 2001-2006 - in \$							
	2001	2002	2003	2004	2005	2006	Annual Change
Ag, Forest, Fish	201,331	219,165	222,677	256,638	328,585	316,490	-3.7%
Mining	131,380	108,849	80,842	121,402	116,614	121,394	4.1%
Construction	505,869	499,818	531,022	554,483	511,596	431,538	-15.6%
Manufacturing	1,122,782	972,235	1,128,627	1,312,672	1,173,608	1,313,060	11.9%
Trans, Comm, Pub Util	6,562,159	7,574,722	8,988,082	7,407,338	7,218,101	8,267,362	14.5%
Wholesale	386,290	208,376	191,402	279,919	216,139	201,937	-6.6%
Retail	41,854,555	41,562,063	38,308,854	44,462,370	45,980,175	49,715,295	8.1%
Finance, Ins, Real Estate	3,197,712	3,351,783	3,003,627	2,633,265	2,484,511	2,773,710	11.6%
Services	8,915,832	9,044,496	8,460,897	8,791,562	8,917,136	9,666,040	8.4%
Government	0	0	0	0	0	0	NA
Total	62,877,910	63,541,507	60,916,030	65,819,649	66,946,465	72,806,826	8.8%
Annual Change		1.1%	-4.1%	8.0%	1.7%	8.8%	

Table 3.4

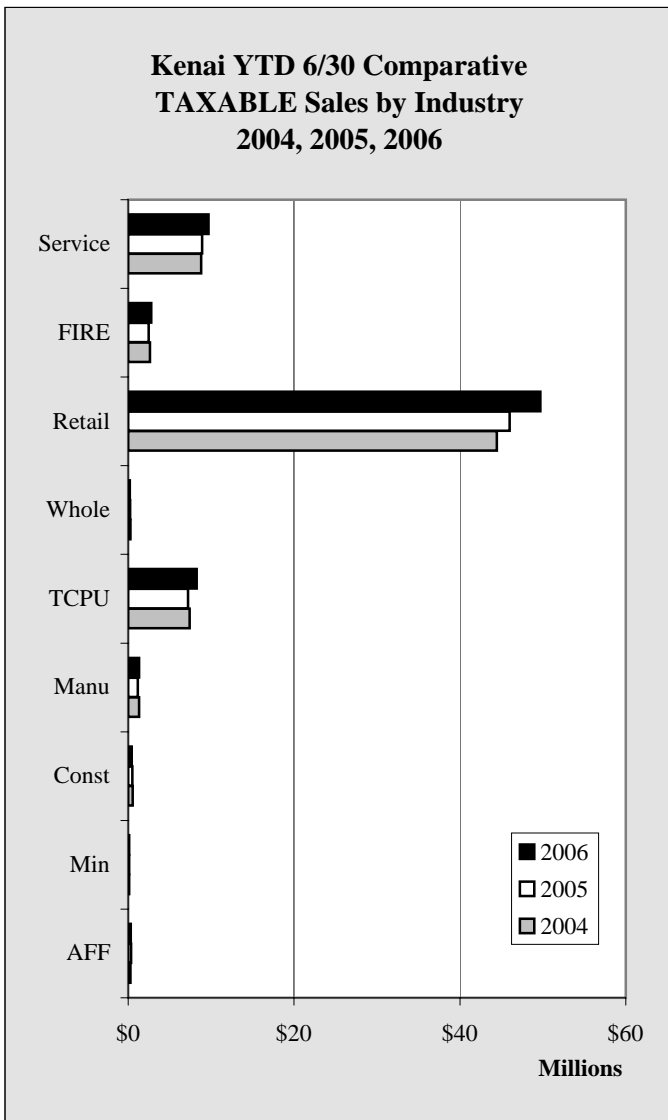

Chart 3.7

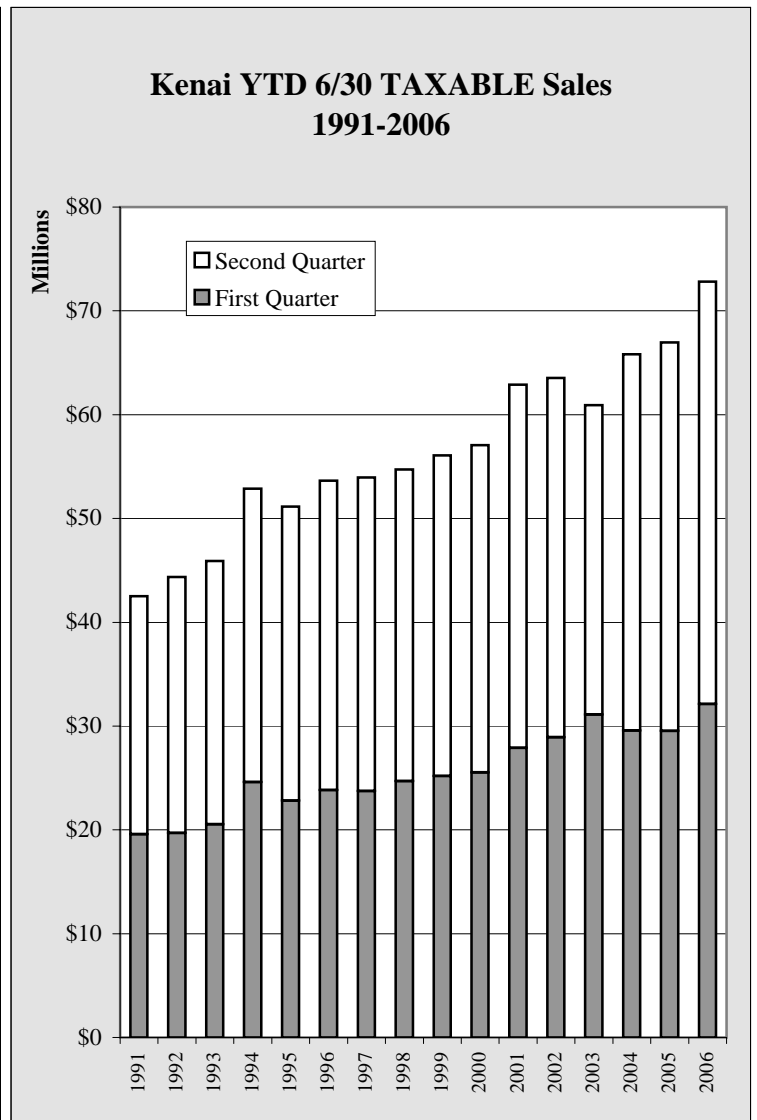

Chart 3.8

Kenai Sales

Kenai Annual GROSS Sales by Industry - 2000-2005 - in \$							
	2000	2001	2002	2003	2004	2005	Annual Change
Ag, Forest, Fish	17,757,626	11,304,090	9,488,174	12,584,181	16,349,894	19,380,387	18.5%
Mining	5,507,130	2,507,234	3,916,074	4,915,930	8,727,840	10,349,611	18.6%
Construction	17,177,398	24,151,985	18,478,747	30,522,706	12,776,832	22,221,456	73.9%
Manufacturing	10,445,806	12,646,047	12,496,147	14,994,862	103,741,304	88,475,943	-14.7%
Trans, Comm, Pub Util	23,883,929	24,107,421	27,762,814	24,667,417	35,991,564	89,601,435	149.0%
Wholesale	17,902,155	19,965,613	17,521,629	19,037,117	24,574,644	21,857,140	-11.1%
Retail	145,306,370	164,046,542	134,565,667	119,219,213	146,054,008	152,039,326	4.1%
Finance, Ins, RE	11,935,000	13,853,920	13,580,836	12,940,552	13,095,553	14,463,877	10.4%
Services	33,766,762	37,842,360	41,942,315	44,532,684	45,266,750	46,320,150	2.3%
Government	288	1,213	0	0	0	0	NA
Total	283,682,464	310,426,425	279,752,403	283,414,662	406,578,389	464,709,325	14.3%
Annual Change		9.4%	-9.9%	1.3%	43.5%	14.3%	

Table 3.5

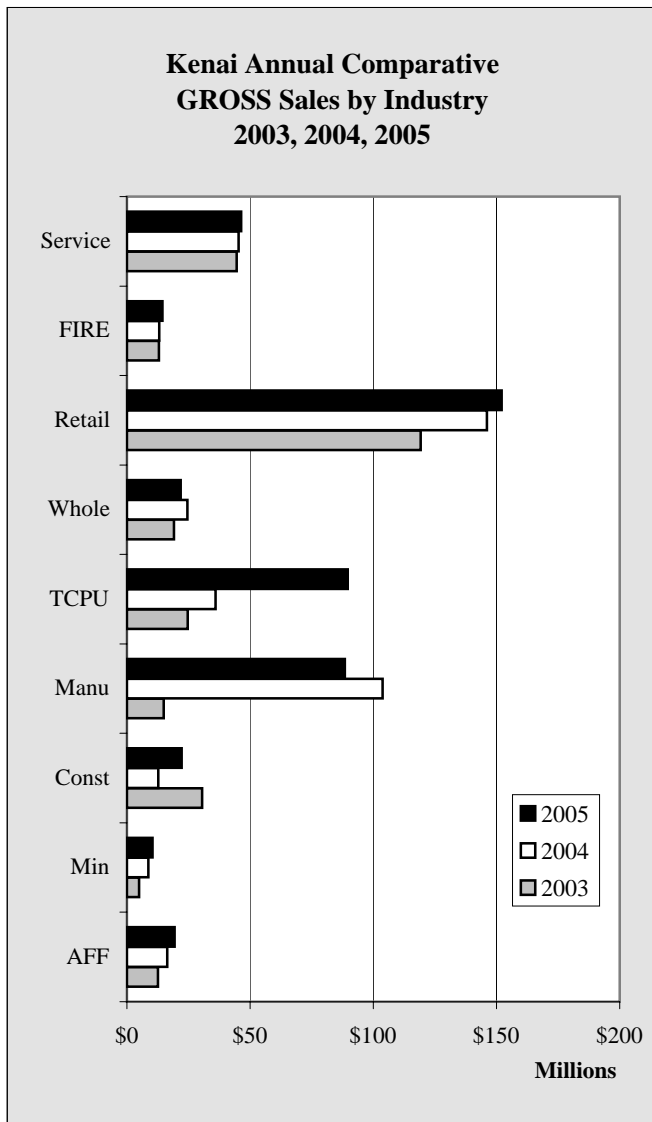

Chart 3.9

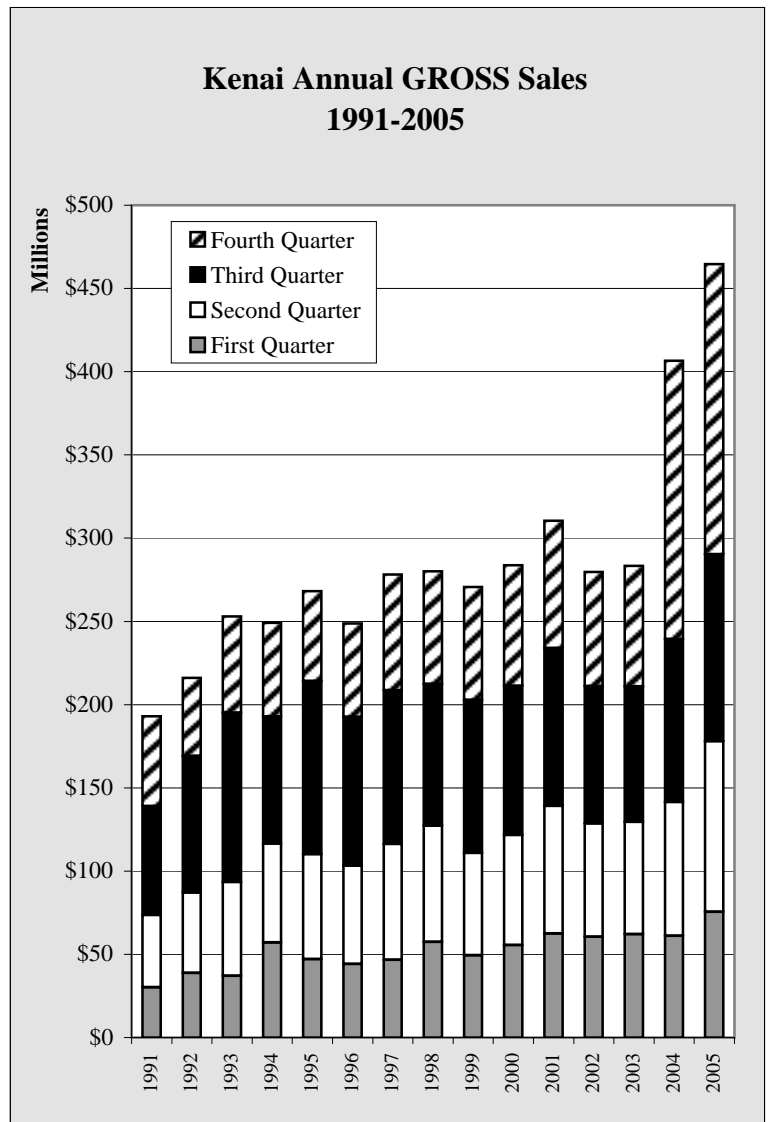

Chart 3.10

Kenai Sales

Kenai Annual TAXABLE Sales by Industry - 2000-2005 - in \$							
	2000	2001	2002	2003	2004	2005	Annual Change
Ag, Forest, Fish	518,603	505,615	505,614	559,313	718,415	897,889	25.0%
Mining	166,846	223,196	213,971	192,718	262,963	255,926	-2.7%
Construction	1,085,964	1,171,924	1,082,406	1,152,569	1,124,337	1,066,360	-5.2%
Manufacturing	2,450,721	2,238,645	2,218,515	2,451,929	2,853,082	2,812,334	-1.4%
Trans, Comm, Pub Util	13,458,834	13,192,948	16,120,066	15,890,944	14,094,256	14,305,684	1.5%
Wholesale	898,759	727,784	425,663	494,254	473,716	431,669	-8.9%
Retail	85,347,467	93,226,651	90,195,938	76,153,080	94,203,581	99,142,914	5.2%
Finance, Ins, Real Estate	5,718,387	6,757,340	6,635,941	5,663,081	5,279,184	5,175,604	-2.0%
Services	18,120,257	18,998,608	19,287,134	18,796,831	19,671,070	20,215,313	2.8%
Government	288	1,213	0	0	0	0	NA
Total	127,766,126	137,043,924	136,685,248	121,354,719	138,680,604	144,303,693	4.1%
Annual Change		7.3%	-0.3%	-11.2%	14.3%	4.1%	

Table 3.6

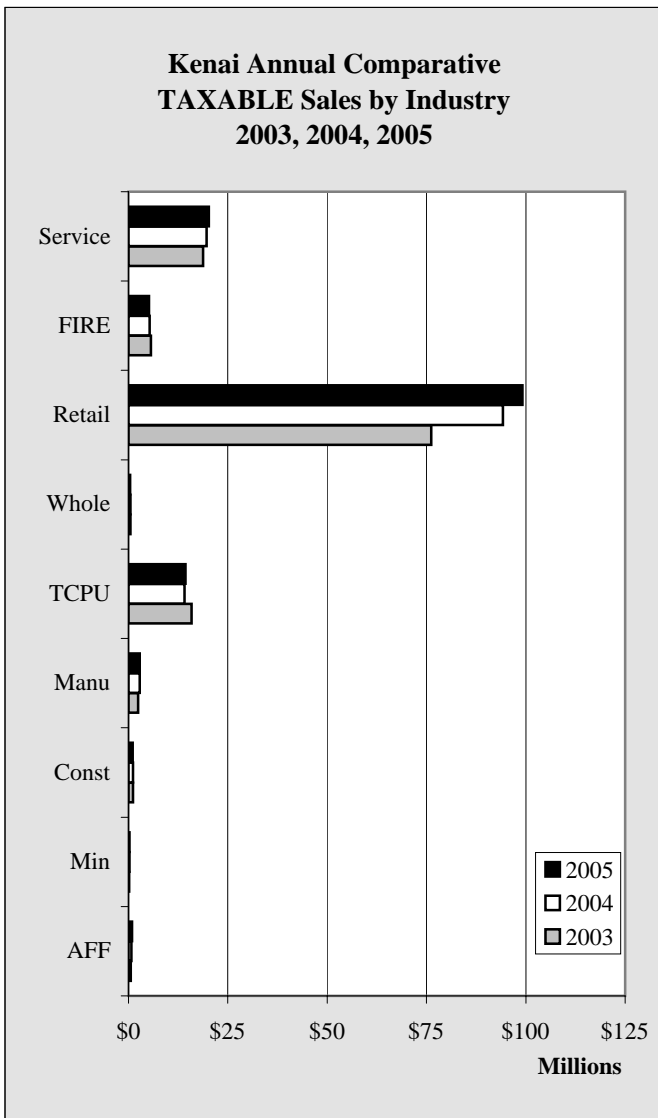

Chart 3.11

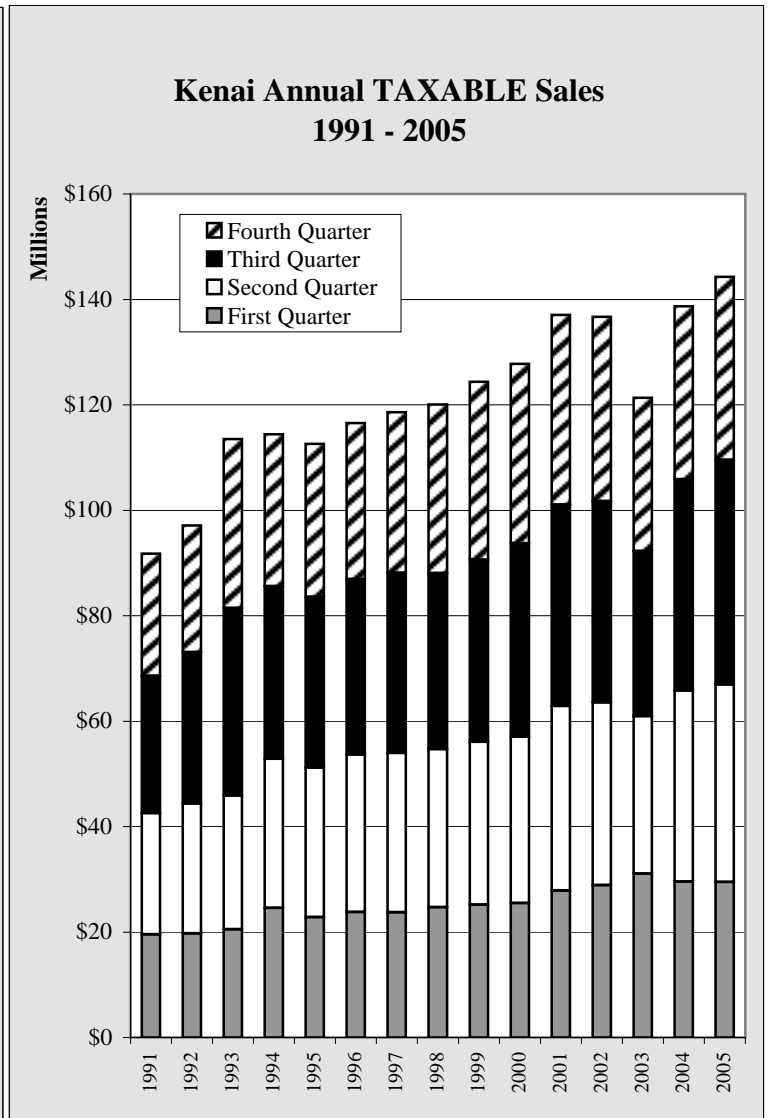

Chart 3.12

Kenai Sales

Kenai GROSS Sales by Industry by Quarter - 2003-2006 - in \$					
	1st Quarter	2nd Quarter	3rd Quarter	4th Quarter	Total
2003					
Ag, Forestry, Fishing	1,002,650	838,734	10,272,676	470,121	12,584,181
Mining	942,570	872,788	1,517,115	1,583,457	4,915,930
Construction	4,091,798	6,395,590	7,848,712	12,186,606	30,522,706
Manufacturing	2,997,006	4,210,293	5,529,544	2,258,019	14,994,862
Trans, Comm, Pub Util	7,714,369	6,152,058	4,859,475	5,941,515	24,667,417
Wholesale	3,221,739	4,841,740	5,639,800	5,333,838	19,037,117
Retail	30,107,230	28,949,996	30,099,399	30,062,588	119,219,213
Finance, Ins, Real Estate	3,084,600	3,326,119	3,155,128	3,374,705	12,940,552
Services	8,988,895	11,847,481	12,318,427	11,377,881	44,532,684
Government	0	0	0	0	0
Total	62,150,857	67,434,799	81,240,276	72,588,730	283,414,662
2004					
Ag, Forestry, Fishing	1,061,786	1,296,885	12,241,519	1,749,704	16,349,894
Mining	2,011,733	2,172,358	2,186,041	2,357,708	8,727,840
Construction	2,270,541	2,705,601	3,619,374	4,181,316	12,776,832
Manufacturing	1,610,022	3,062,848	2,757,875	96,310,559	103,741,304
Trans, Comm, Pub Util	6,489,016	11,662,099	11,816,038	6,024,411	35,991,564
Wholesale	5,349,782	5,842,357	7,155,295	6,227,210	24,574,644
Retail	29,814,280	39,251,887	40,497,690	36,490,151	146,054,008
Finance, Ins, Real Estate	2,918,854	3,294,005	3,445,709	3,436,985	13,095,553
Services	9,556,990	11,099,322	14,140,495	10,469,943	45,266,750
Government	0	0	0	0	0
Total	61,083,004	80,387,362	97,860,036	167,247,987	406,578,389
2005					
Ag, Forestry, Fishing	1,613,553	2,360,990	14,151,132	1,254,712	19,380,387
Mining	2,243,621	1,068,085	3,231,706	3,806,199	10,349,611
Construction	1,969,537	6,371,616	8,635,010	5,245,293	22,221,456
Manufacturing	1,707,686	3,408,122	9,019,116	74,341,019	88,475,943
Trans, Comm, Pub Util	20,315,610	28,241,441	8,811,103	32,233,281	89,601,435
Wholesale	4,974,303	6,590,438	7,171,027	3,121,372	21,857,140
Retail	30,499,039	40,309,307	42,702,143	38,528,837	152,039,326
Finance, Ins, Real Estate	2,684,437	3,223,641	3,639,488	4,916,311	14,463,877
Services	9,563,414	10,894,305	14,938,772	10,923,659	46,320,150
Government	0	0	0	0	0
Total	75,571,200	102,467,945	112,299,497	174,370,683	464,709,325
2006					
				Year to Date	
Ag, Forestry, Fishing	348,792	2,235,504			2,584,296
Mining	1,414,084	1,896,271			3,310,355
Construction	1,536,554	3,815,073			5,351,627
Manufacturing	2,441,944	2,668,548			5,110,492
Trans, Comm, Pub Util	8,898,462	27,464,229			36,362,691
Wholesale	1,973,703	2,924,153			4,897,856
Retail	33,478,761	49,003,254			82,482,015
Finance, Ins, Real Estate	3,022,641	3,412,012			6,434,653
Services	9,899,969	12,923,253			22,823,222
Government	0	0			0
Total	63,014,910	106,342,297	0	0	169,357,207

Table 3.7

Kenai Sales

Kenai TAXABLE Sales by Industry by Quarter - 2003-2006 - in \$					
	1st Quarter	2nd Quarter	3rd Quarter	4th Quarter	Total
2003					
Ag, Forestry, Fishing	87,894	134,783	237,344	99,292	559,313
Mining	34,119	46,723	51,411	60,465	192,718
Construction	236,553	294,469	312,562	308,985	1,152,569
Manufacturing	441,292	687,335	816,883	506,419	2,451,929
Trans, Comm, Pub Util	4,932,006	4,056,076	3,270,630	3,632,232	15,890,944
Wholesale	79,538	111,864	145,387	157,465	494,254
Retail	20,062,767	18,246,087	19,174,865	18,669,361	76,153,080
Finance, Ins, Real Estate	1,496,823	1,506,804	1,387,466	1,271,988	5,663,081
Services	3,732,984	4,727,913	5,965,690	4,370,244	18,796,831
Government	0	0	0	0	0
Total	31,103,976	29,812,054	31,362,238	29,076,451	121,354,719
2004					
Ag, Forestry, Fishing	97,275	159,363	351,638	110,139	718,415
Mining	63,827	57,575	75,540	66,021	262,963
Construction	263,404	291,079	307,561	262,293	1,124,337
Manufacturing	508,762	803,910	1,023,087	517,323	2,853,082
Trans, Comm, Pub Util	3,939,435	3,467,903	3,197,445	3,489,473	14,094,256
Wholesale	152,309	127,610	109,725	84,072	473,716
Retail	19,316,910	25,145,460	26,972,082	22,769,129	94,203,581
Finance, Ins, Real Estate	1,273,853	1,359,412	1,373,838	1,272,081	5,279,184
Services	3,940,716	4,850,846	6,631,650	4,247,858	19,671,070
Government	0	0	0	0	0
Total	29,556,491	36,263,158	40,042,566	32,818,389	138,680,604
2005					
Ag, Forestry, Fishing	141,622	186,963	426,480	142,824	897,889
Mining	70,218	46,396	52,988	86,324	255,926
Construction	195,212	316,384	250,105	304,659	1,066,360
Manufacturing	436,084	737,524	1,089,001	549,725	2,812,334
Trans, Comm, Pub Util	3,897,696	3,320,405	3,363,068	3,724,515	14,305,684
Wholesale	90,018	126,121	123,876	91,654	431,669
Retail	19,582,443	26,397,732	28,938,750	24,223,989	99,142,914
Finance, Ins, Real Estate	1,194,305	1,290,206	1,352,363	1,338,730	5,175,604
Services	3,912,429	5,004,707	6,990,262	4,307,915	20,215,313
Government	0	0	0	0	0
Total	29,520,027	37,426,438	42,586,893	34,770,335	144,303,693
2006					
				Year to Date	
Ag, Forestry, Fishing	132,654	183,836			316,490
Mining	60,612	60,782			121,394
Construction	206,068	225,470			431,538
Manufacturing	518,752	794,308			1,313,060
Trans, Comm, Pub Util	4,535,781	3,731,581			8,267,362
Wholesale	74,705	127,232			201,937
Retail	21,041,281	28,674,014			49,715,295
Finance, Ins, Real Estate	1,329,919	1,443,791			2,773,710
Services	4,215,258	5,450,782			9,666,040
Government	0	0			0
Total	32,115,030	40,691,796	0	0	72,806,826

Table 3.8

Kenai Construction

Kenai 2nd Quarter Permit VALUES by Type - 2001-2006 - in \$							
	2001	2002	2003	2004	2005	2006	Annual Change
Residential - New	2,886,000	2,362,000	1,943,000	1,079,000	1,883,500	3,383,000	79.6%
Residential - Add/Alter	228,300	323,100	515,200	52,200	131,300	305,700	132.8%
Commercial - New	3,744,000	1,480,000	0	81,000	45,000	60,000	33.3%
Commercial - Add/Alter	739,600	404,300	270,150	685,200	497,500	408,400	-17.9%
TOTAL	7,597,900	4,569,400	2,728,350	1,897,400	2,557,300	4,157,100	62.6%
Annual Change		-39.9%	-40.3%	-30.5%	34.8%	62.6%	

Table 3.9

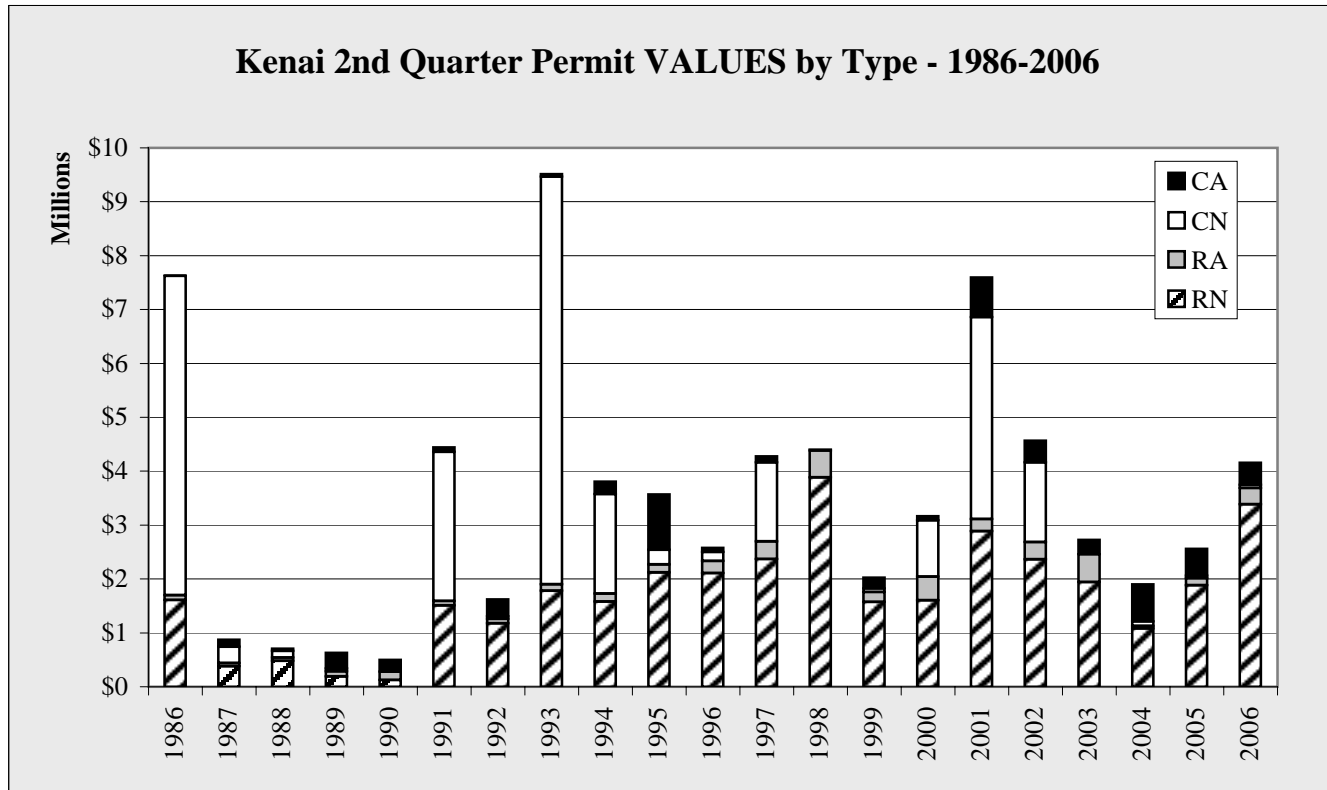

Chart 3.13

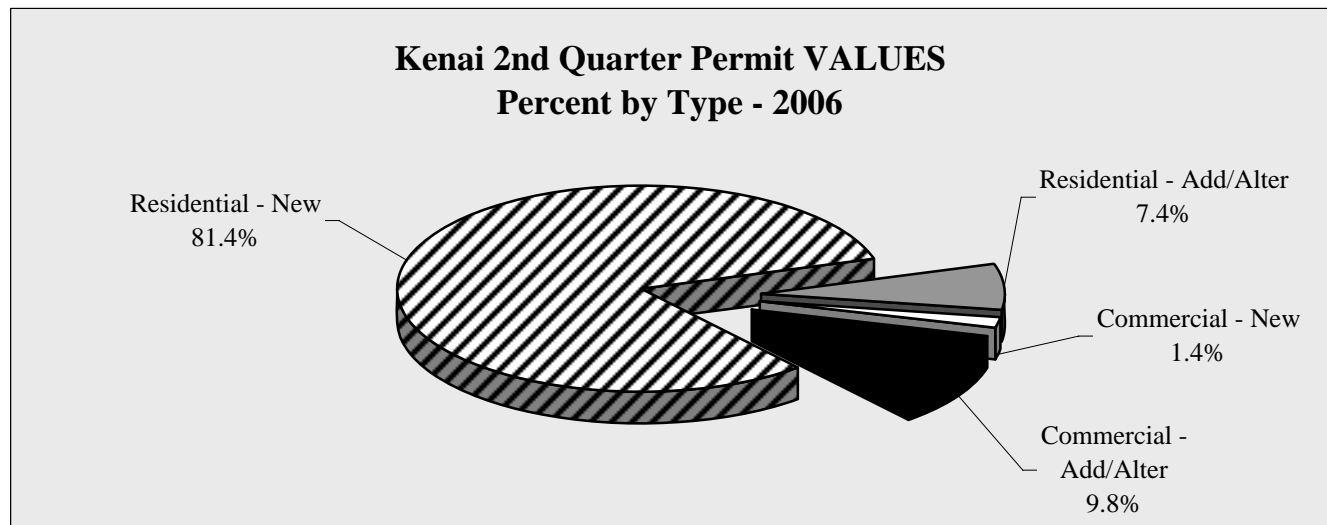

Chart 3.14

Kenai Construction

Kenai 2nd Quarter Permit VOLUME by Type - 2001-2006							
	2001	2002	2003	2004	2005	2006	Annual Change
Residential - New	16	18	13	5	11	16	45.5%
Residential - Add/Alter	13	14	16	8	11	16	45.5%
Commercial - New	3	3	0	2	2	1	-50.0%
Commercial - Add/Alter	10	2	11	15	9	9	0.0%
TOTAL	42	37	40	30	33	42	27.3%
Annual Change		-11.9%	8.1%	-25.0%	10.0%	27.3%	

Table 3.10

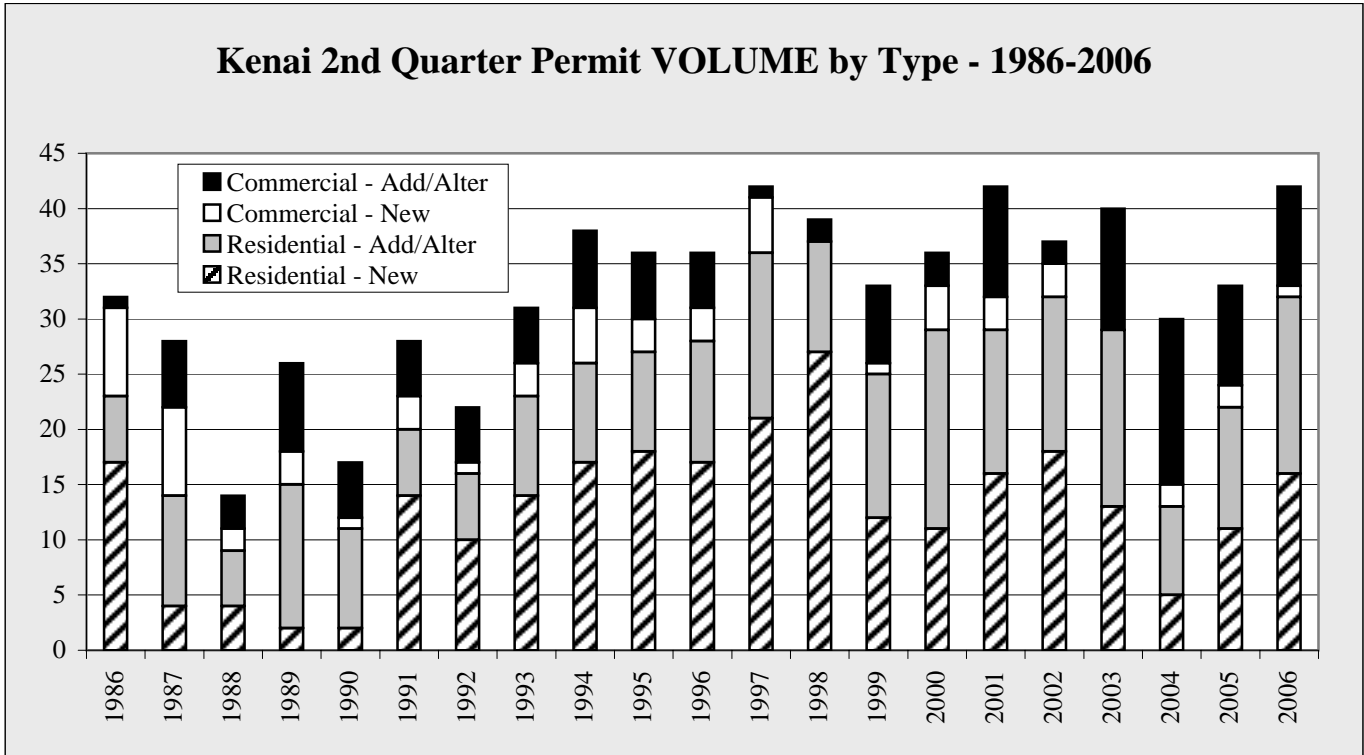

Chart 3.15

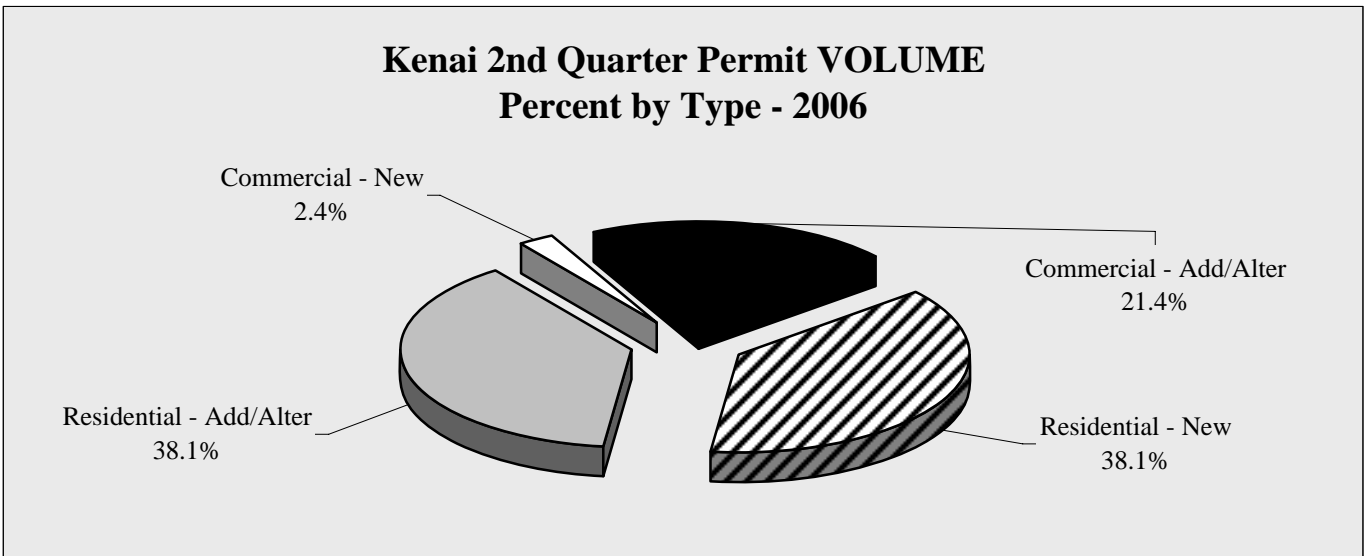

Chart 3.16

Kenai Construction

Kenai YTD 6/30 Permit VALUES by Type - 2001-2006 - in \$							
	2001	2002	2003	2004	2005	2006	Annual Change
Residential - New	3,509,000	2,641,000	1,943,000	1,379,000	1,883,500	3,761,000	99.7%
Residential - Add/Alter	389,800	351,100	530,200	64,200	265,800	339,700	27.8%
Commercial - New	3,759,000	5,059,200	0	81,000	45,000	60,000	33.3%
Commercial - Add/Alter	759,600	406,300	1,812,750	685,200	788,500	759,900	-3.6%
TOTAL	8,417,400	8,457,600	4,285,950	2,209,400	2,982,800	4,920,600	65.0%
Annual Change		0.5%	-49.3%	-48.5%	35.0%	65.0%	

Table 3.11

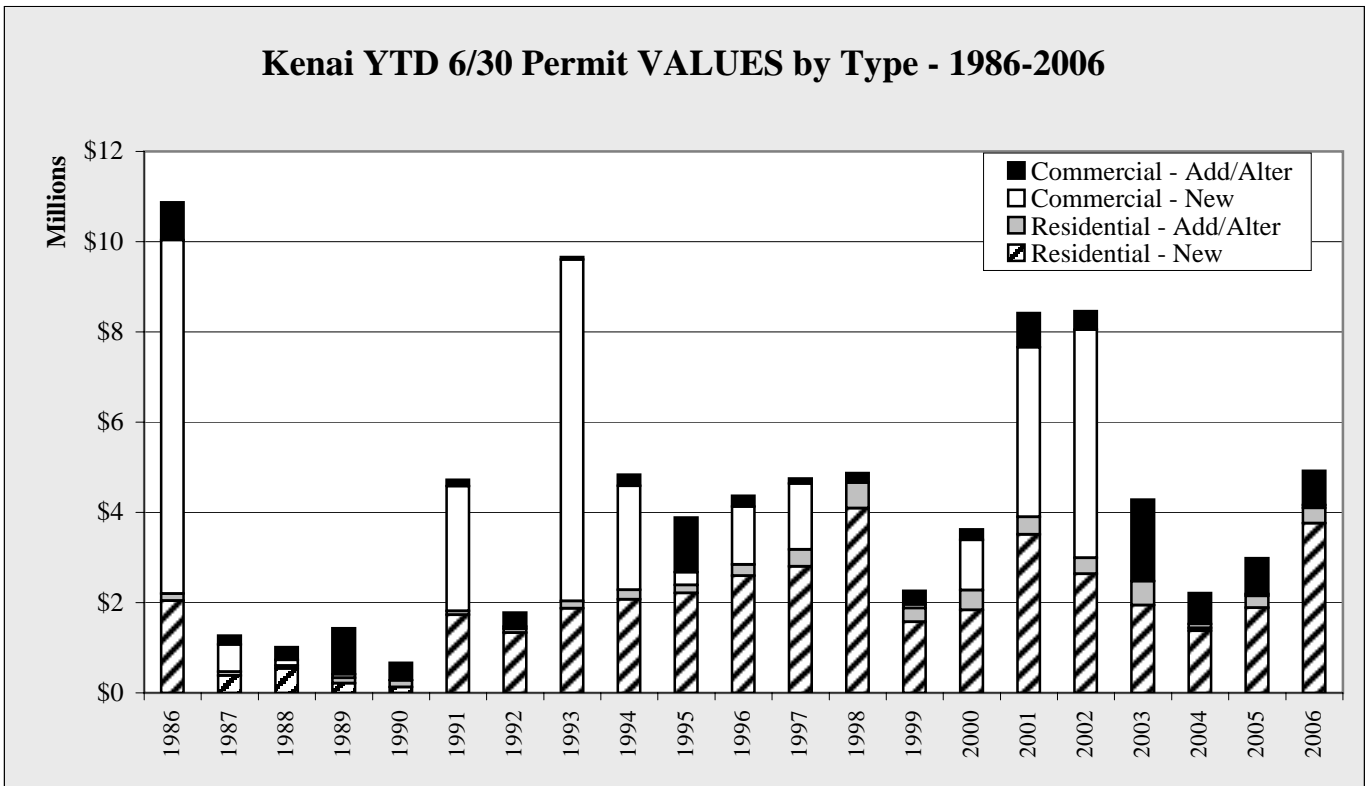

Chart 3.17

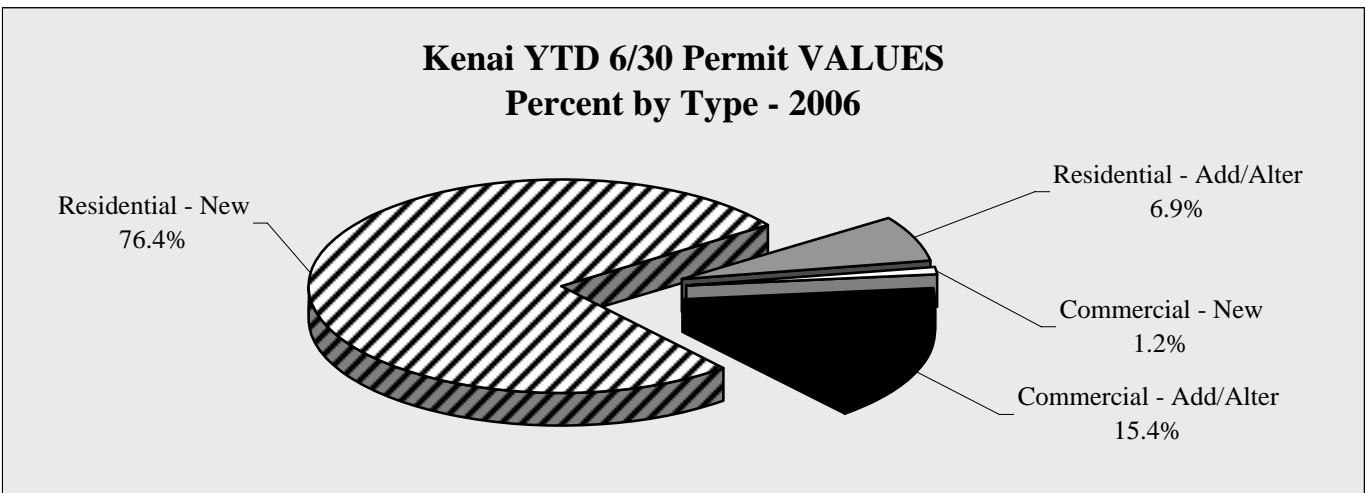

Chart 3.18

Kenai Construction

Kenai YTD 6/30 Permit VOLUME by Type - 2001-2006

	2001	2002	2003	2004	2005	2006	Annual Change
Residential - New	20	20	13	8	11	18	63.6%
Residential - Add/Alter	18	15	17	9	18	19	5.6%
Commercial - New	4	4	0	2	2	1	-50.0%
Commercial - Add/Alter	11	3	18	15	12	18	50.0%
TOTAL	53	42	48	34	43	56	30.2%
Annual Change		-20.8%	14.3%	-29.2%	26.5%	30.2%	

Table 3.12

Kenai YTD 6/30 Permit VOLUME by Type - 1986-2006

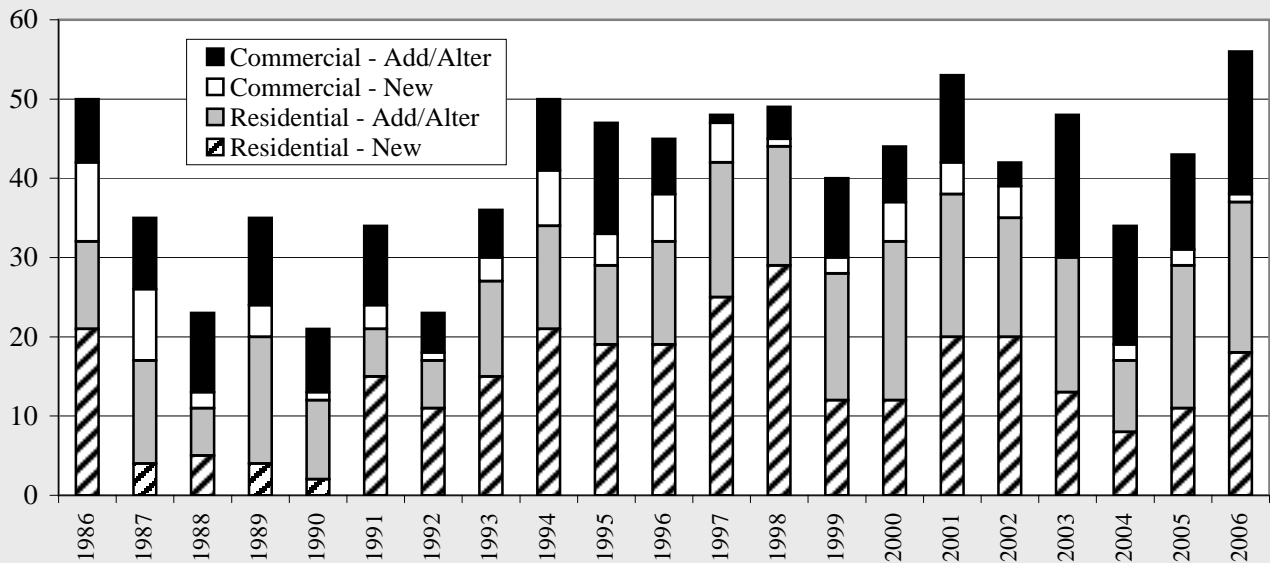

Chart 3.19

**Kenai YTD 6/30 Permit VOLUME
Percent by Type - 2006**

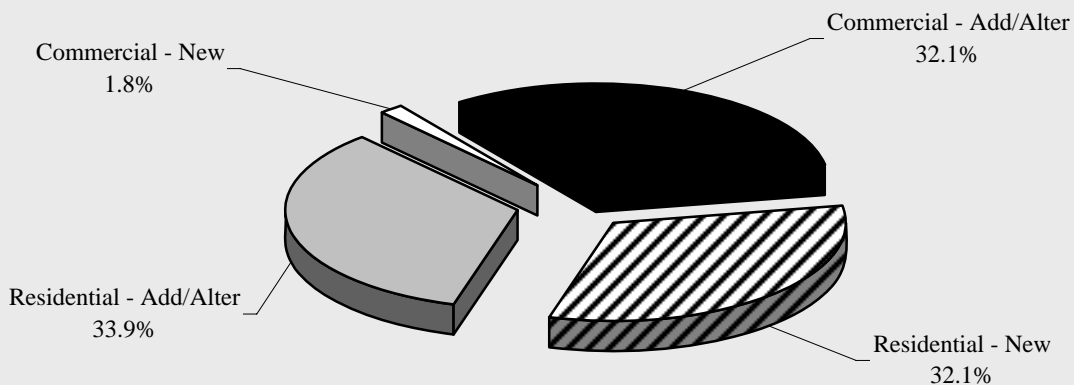

Chart 3.20

Kenai Construction

Kenai Annual Permit VALUES by Type by Quarter - 2000-2006 - in \$					
	1st Quarter	2nd Quarter	3rd Quarter	4th Quarter	Total
2000					
Residential - New	228,000	1,606,000	1,287,000	376,000	3,497,000
Residential - Add/Alter	7,000	439,000	387,000	55,400	888,400
Commercial - New	65,000	1,045,000	2,896,000	244,000	4,250,000
Commercial - Add/Alter	162,900	73,000	524,000	2,800	762,700
TOTAL	462,900	3,163,000	5,094,000	678,200	9,398,100
2001					
Residential - New	623,000	2,886,000	1,152,000	324,000	4,985,000
Residential - Add/Alter	161,500	228,300	217,500	67,800	675,100
Commercial - New	15,000	3,744,000	1,406,700	214,000	5,379,700
Commercial - Add/Alter	20,000	739,600	1,730,000	49,500	2,539,100
TOTAL	819,500	7,597,900	4,506,200	655,300	13,578,900
2002					
Residential - New	279,000	2,362,000	2,899,000	377,000	5,917,000
Residential - Add/Alter	28,000	323,100	302,400	70,000	723,500
Commercial - New	3,579,200	1,480,000	212,000	990,000	6,261,200
Commercial - Add/Alter	2,000	404,300	3,400,600	90,800	3,897,700
TOTAL	3,888,200	4,569,400	6,814,000	1,527,800	16,799,400
2003					
Residential - New	0	1,943,000	560,000	779,000	3,282,000
Residential - Add/Alter	15,000	515,200	168,850	183,000	882,050
Commercial - New	0	0	51,000	253,000	304,000
Commercial - Add/Alter	1,542,600	270,150	2,920,500	1,240,500	5,973,750
TOTAL	1,557,600	2,728,350	3,700,350	2,455,500	10,441,800
2004					
Residential - New	300,000	1,079,000	1,197,500	482,000	3,058,500
Residential - Add/Alter	12,000	52,200	308,950	27,000	400,150
Commercial - New	0	81,000	250,000	0	331,000
Commercial - Add/Alter	0	685,200	235,300	76,400	996,900
TOTAL	312,000	1,897,400	1,991,750	585,400	4,786,550
2005					
Residential - New	0	1,883,500	1,544,000	946,000	4,373,500
Residential - Add/Alter	134,500	131,300	306,600	78,500	650,900
Commercial - New	0	45,000	1,000,000	128,000	1,173,000
Commercial - Add/Alter	291,000	497,500	1,184,500	67,500	2,040,500
TOTAL	425,500	2,557,300	4,035,100	1,220,000	8,237,900
2006					
				Year to Date	
Residential - New	378,000	3,383,000			3,761,000
Residential - Add/Alter	34,000	305,700			339,700
Commercial - New	0	60,000			60,000
Commercial - Add/Alter	351,500	408,400			759,900
TOTAL	763,500	4,157,100			4,920,600

Table 3.13

Kenai Construction

Kenai Annual Permit VOLUME by Type by Quarter - 2000-2006					
	1st Quarter	2nd Quarter	3rd Quarter	4th Quarter	Total
2000					
Residential - New	1	11	11	3	26
Residential - Add/Alter	2	18	18	7	45
Commercial - New	1	4	4	2	11
Commercial - Add/Alter	4	3	3	1	11
TOTAL	8	36	36	13	93
2001					
Residential - New	4	16	8	2	30
Residential Add/Alter	5	13	8	5	31
Commercial - New	1	3	3	1	8
Commercial - Add/Alter	1	10	4	3	18
TOTAL	11	42	23	11	87
2002					
Residential - New	2	18	19	3	42
Residential Add/Alter	1	14	26	4	45
Commercial - New	1	3	2	3	9
Commercial - Add/Alter	1	2	12	10	25
TOTAL	5	37	59	20	121
2003					
Residential - New	0	13	3	6	22
Residential Add/Alter	1	16	22	5	44
Commercial - New	0	0	2	2	4
Commercial - Add/Alter	7	11	18	8	44
TOTAL	8	40	45	21	114
2004					
Residential - New	3	5	8	4	20
Residential Add/Alter	1	8	12	4	25
Commercial - New	0	2	1	0	3
Commercial - Add/Alter	0	15	10	6	31
TOTAL	4	30	31	14	79
2005					
Residential - New	0	11	8	5	24
Residential Add/Alter	7	11	14	4	36
Commercial - New	0	2	1	1	4
Commercial - Add/Alter	3	9	10	4	26
TOTAL	10	33	33	14	90
2006					
				Year to Date	
Residential - New	2	16			18
Residential Add/Alter	3	16			19
Commercial - New	0	1			1
Commercial - Add/Alter	9	9			18
TOTAL	14	42			56

Table 3.14

Seldovia Sales

Seldovia 2nd Quarter GROSS Sales by Industry - 2001-2006 - in \$							
	2001	2002	2003	2004	2005	2006	Annual Change
Ag, Forestry, Fishing	3,707	6,306	5,737	11,260	0	0	NA
Mining	0	0	0	0	0	0	NA
Construction	287,028	42,719	213,775	763,635	412,463	136,390	-66.9%
Manufacturing	14,430	5,911	25,326	8,735	36,891	33,668	-8.7%
Tran, Comm, Pub Util	138,629	136,379	135,580	152,078	177,421	221,184	24.7%
Wholesale	13,490	7,040	17,477	26,237	35,271	34,949	-0.9%
Retail	758,967	690,215	711,358	722,686	745,371	806,094	8.1%
Finance, Ins, Real Estate	17,006	8,734	242,188	10,170	424,120	579,537	36.6%
Service	240,048	257,751	278,014	276,869	288,997	327,989	13.5%
Total	1,473,305	1,155,055	1,629,455	1,971,670	2,120,534	2,139,811	0.9%
Annual Change		-21.6%	41.1%	21.0%	7.6%	0.9%	

Table 4.1

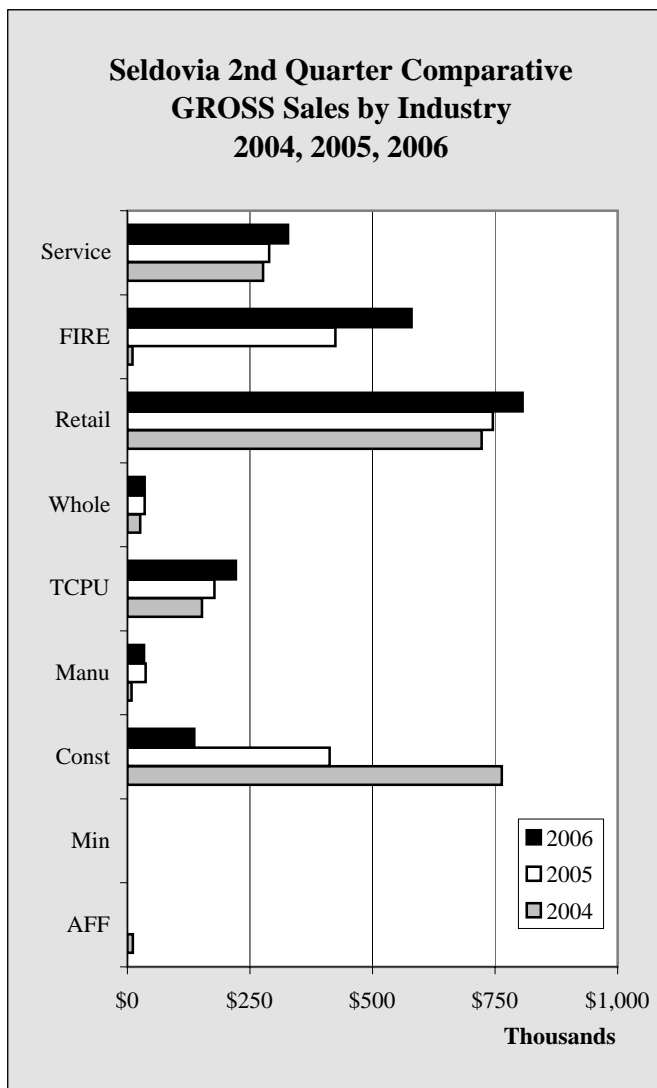

Chart 4.1

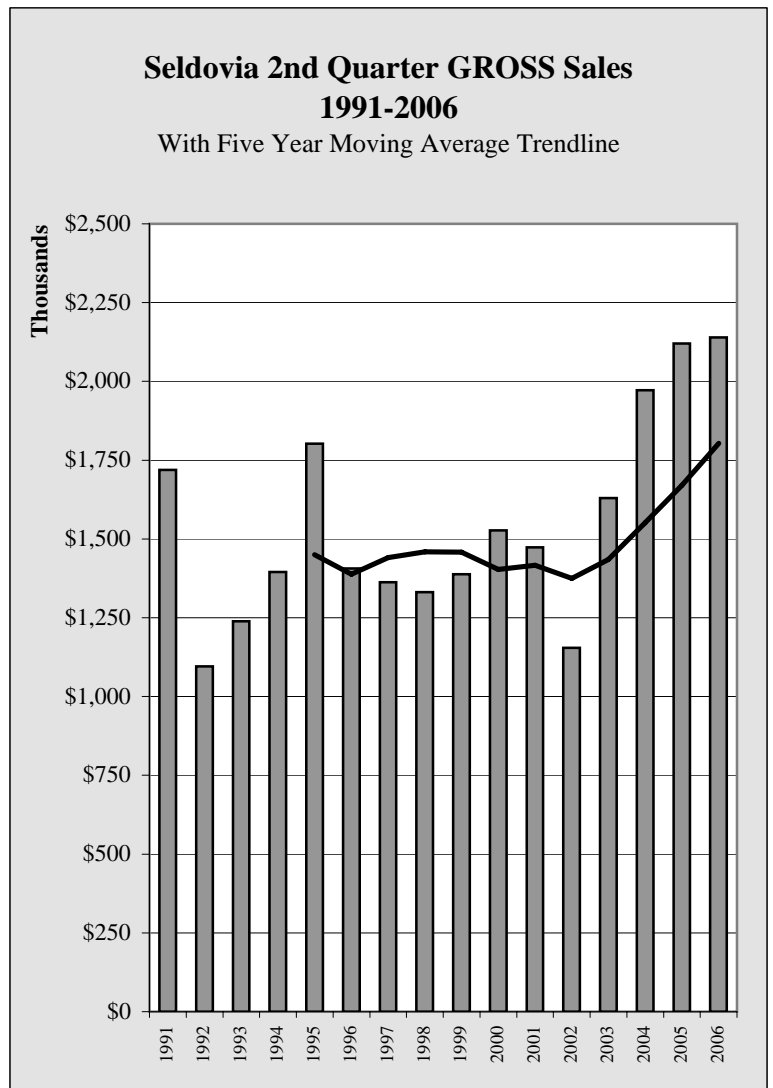

Chart 4.2

Seldovia Sales

Seldovia 2nd Quarter TAXABLE Sales by Industry - 2001-2006 - in \$							
	2001	2002	2003	2004	2005	2006	Annual Change
Ag, Forestry, Fishing	3,616	3,551	2,970	3,140	0	0	NA
Mining	0	0	0	0	0	0	NA
Construction	9,498	9,130	9,946	8,058	5,615	6,858	22.1%
Manufacturing	1,243	1,806	1,749	2,135	2,819	4,421	56.8%
Tran, Comm, Pub Util	94,825	95,299	96,701	105,084	108,937	113,771	4.4%
Wholesale	1,305	135	321	137	51	216	323.5%
Retail	657,146	590,349	620,851	613,360	591,323	653,897	10.6%
Finance, Ins, Real Estate	7,434	6,144	9,430	8,540	10,740	14,257	32.7%
Service	180,966	192,416	220,998	199,135	212,656	150,079	-29.4%
Total	956,033	898,830	962,966	939,589	932,141	943,499	1.2%
Annual Change		-6.0%	7.1%	-2.4%	-0.8%	1.2%	

Table 4.2

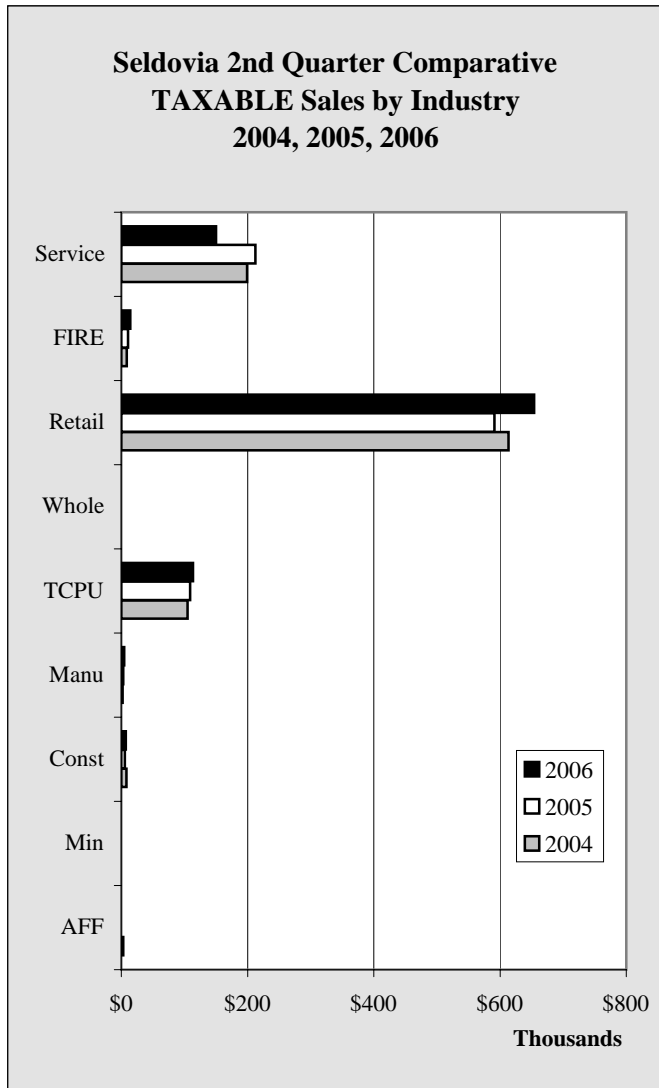

Chart 4.3

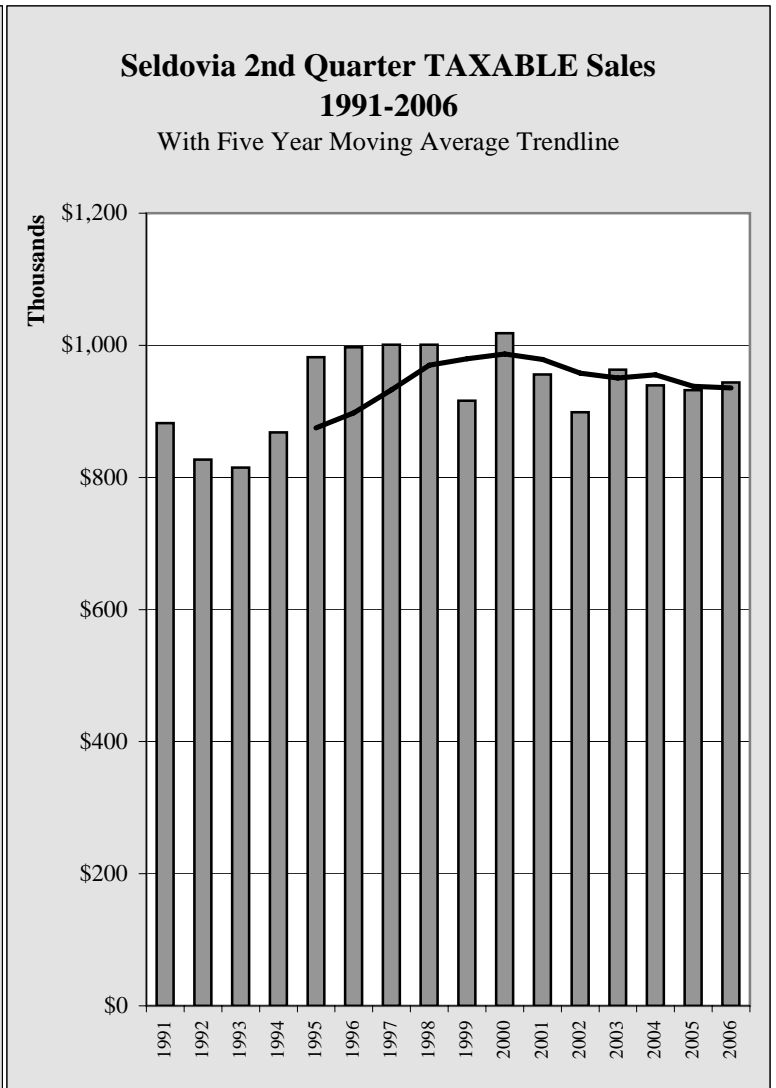

Chart 4.4

Seldovia Sales

Seldovia YTD 6/30 GROSS Sales by Industry - 2001-2006 - in \$							
	2001	2002	2003	2004	2005	2006	Annual Change
Ag, Forestry, Fishing	3,707	6,306	5,737	11,260	0	0	NA
Mining	0	0	0	0	0	0	NA
Construction	317,051	109,501	241,722	1,365,011	847,122	238,128	-71.9%
Manufacturing	17,419	7,615	27,171	9,984	38,222	53,522	40.0%
Tran, Comm, Pub Util	300,653	299,624	283,329	303,826	338,410	450,960	33.3%
Wholesale	39,176	10,800	26,678	40,387	48,169	45,946	-4.6%
Retail	1,312,363	1,175,694	1,255,678	1,245,323	1,278,695	1,396,178	9.2%
Finance, Ins, Real Estate	40,830	167,402	249,278	19,297	440,129	1,004,378	128.2%
Service	340,917	389,825	386,867	381,629	391,522	466,937	19.3%
Total	2,372,116	2,166,767	2,476,460	3,376,717	3,382,269	3,656,049	8.1%
Annual Change		-8.7%	14.3%	36.4%	0.2%	8.1%	

Table 4.3

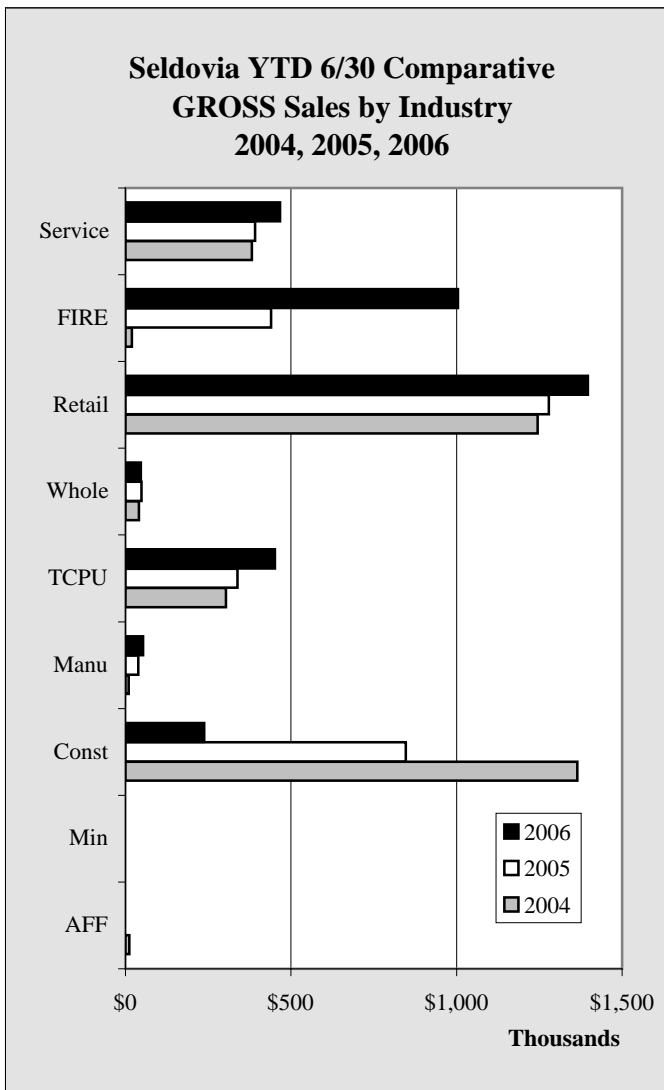

Chart 4.5

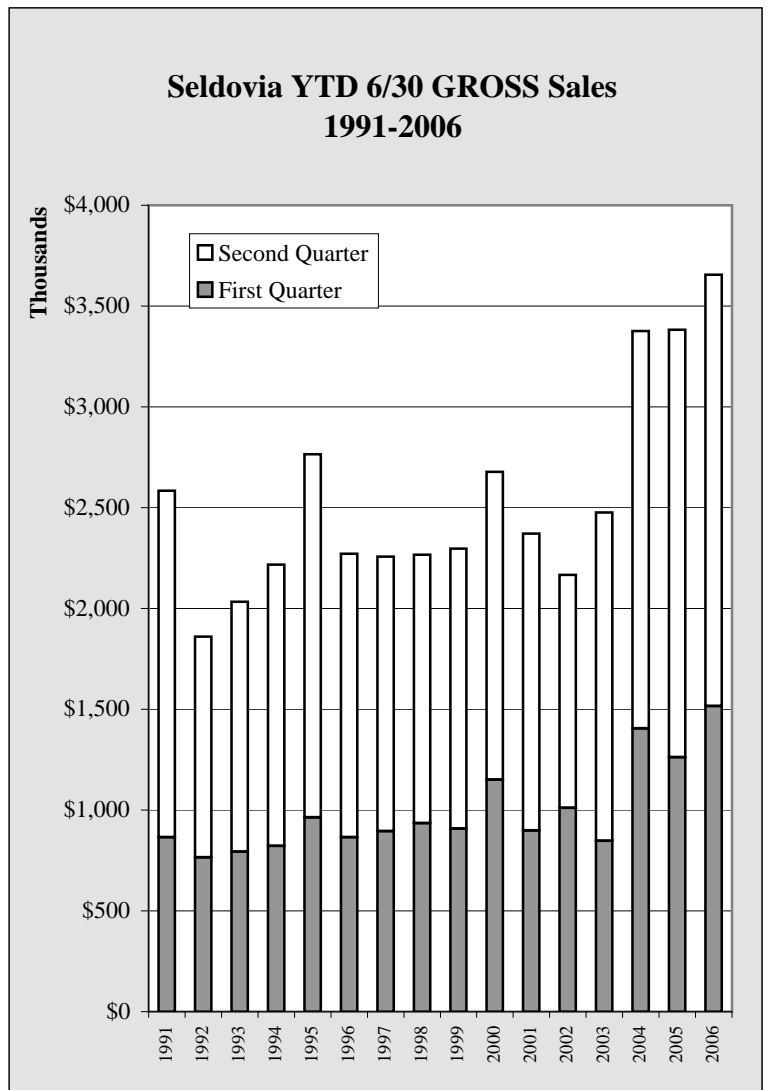

Chart 4.6

Seldovia Sales

Seldovia YTD 6/30 TAXABLE Sales by Industry - 2001-2006 - in \$							
	2001	2002	2003	2004	2005	2006	Annual Change
Ag, Forestry, Fishing	3,616	3,551	2,970	3,140	0	0	NA
Mining	0	0	0	0	0	0	NA
Construction	17,093	16,110	11,077	13,218	10,270	13,223	28.8%
Manufacturing	2,297	3,000	2,117	2,784	3,650	7,923	117.1%
Tran, Comm, Pub Util	212,013	210,320	200,393	202,073	211,094	235,434	11.5%
Wholesale	1,555	294	471	167	126	291	131.0%
Retail	1,049,195	957,765	1,035,907	1,005,601	981,335	1,047,092	6.7%
Finance, Ins, Real Estate	13,823	13,322	14,030	14,482	21,944	29,700	35.3%
Service	239,996	268,092	294,971	264,850	276,739	245,648	-11.2%
Total	1,539,588	1,472,454	1,561,936	1,506,315	1,505,158	1,579,311	4.9%
Annual Change		-4.4%	6.1%	-3.6%	-0.1%	4.9%	

Table 4.4

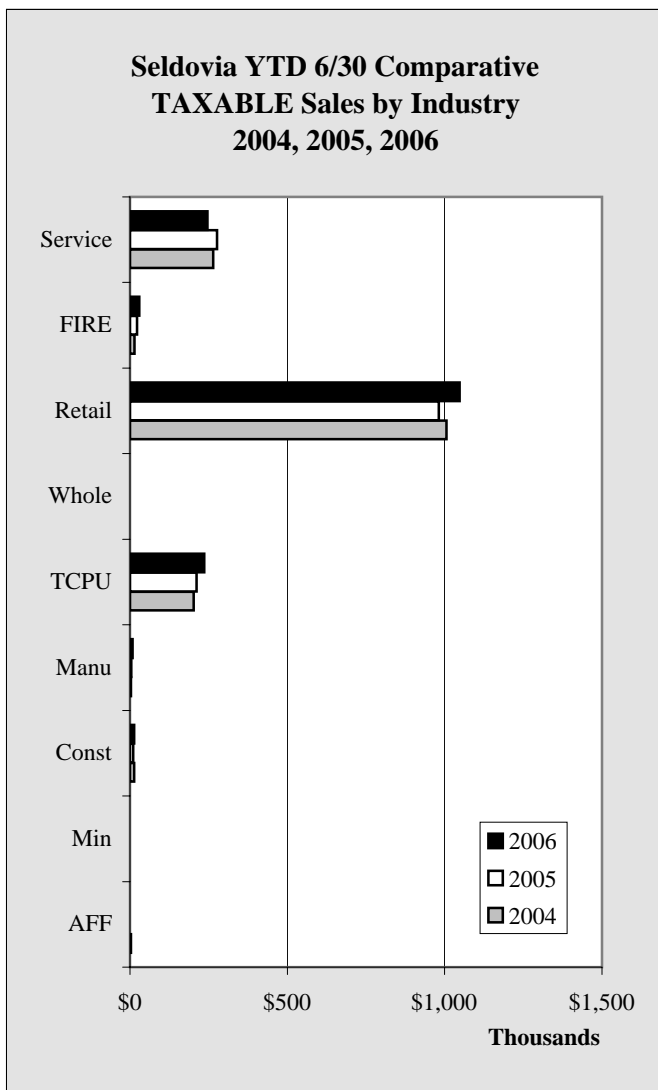

Chart 4.7

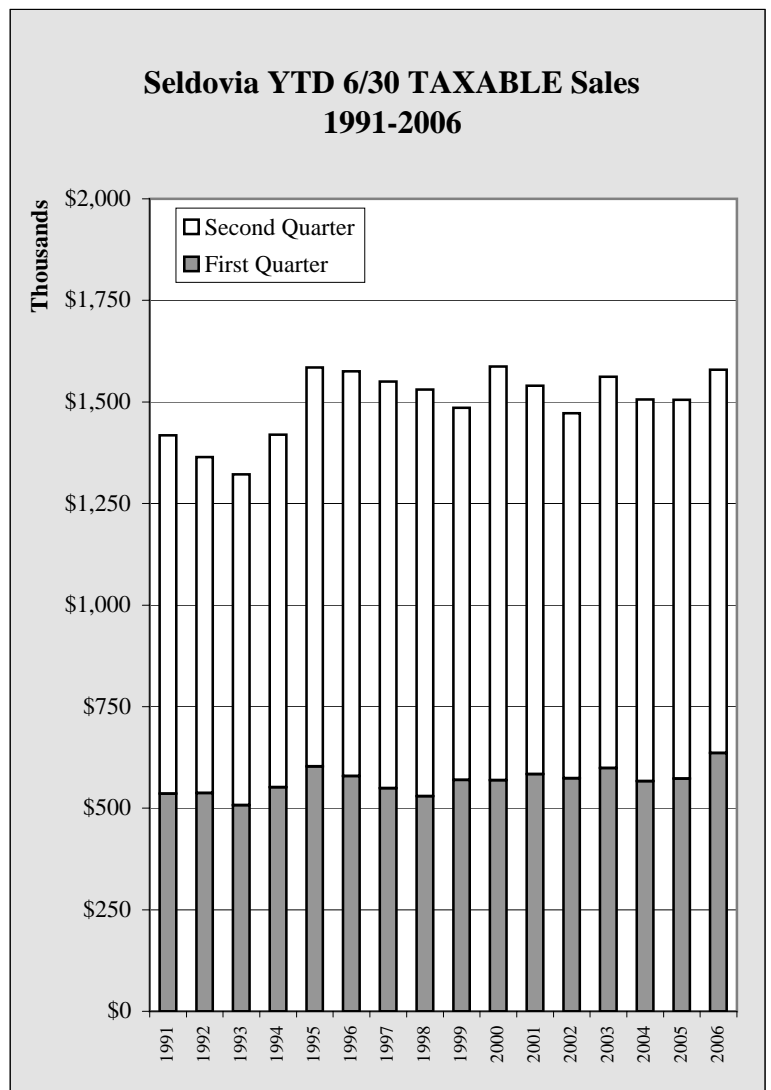

Chart 4.8

Seldovia Sales

Seldovia Annual GROSS Sales by Industry - 2000-2005 - in \$							
	2000	2001	2002	2003	2004	2005	Annual Change
Ag, Forestry, Fishing	2,797	3,787	6,306	5,737	28,760	0	-100.0%
Mining	0	0	0	0	0	0	NA
Construction	567,881	427,249	233,790	2,235,069	2,432,152	1,356,822	-44.2%
Manufacturing	22,483	40,983	41,694	44,136	24,563	151,322	516.1%
Tran, Comm, Pub Util	642,067	615,305	589,101	609,377	621,624	690,200	11.0%
Wholesale	74,511	58,140	40,755	143,974	105,348	90,985	-13.6%
Retail	2,969,768	2,710,711	2,527,071	2,565,299	2,640,802	2,775,660	5.1%
Finance, Ins, Real Estate	62,750	509,244	443,797	590,854	1,450,792	812,020	-44.0%
Service	925,068	884,052	935,363	1,065,108	1,025,790	992,683	-3.2%
Total	5,267,325	5,249,471	4,817,877	7,259,554	8,329,831	6,869,692	-17.5%
Annual Change		-0.3%	-8.2%	50.7%	14.7%	-17.5%	

Table 4.5

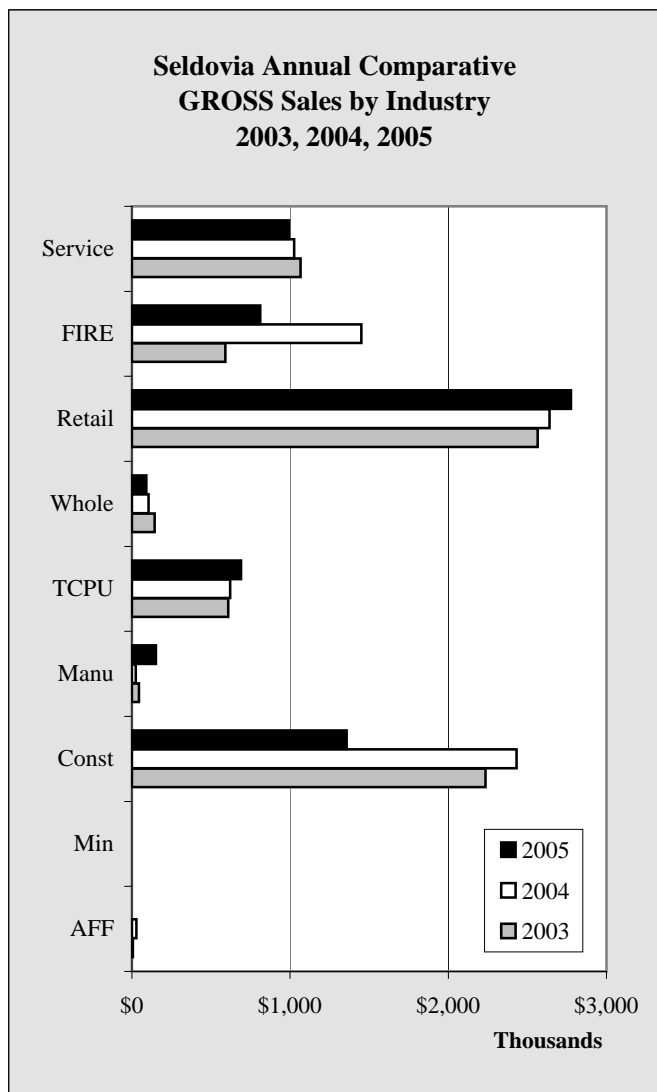

Chart 4.9

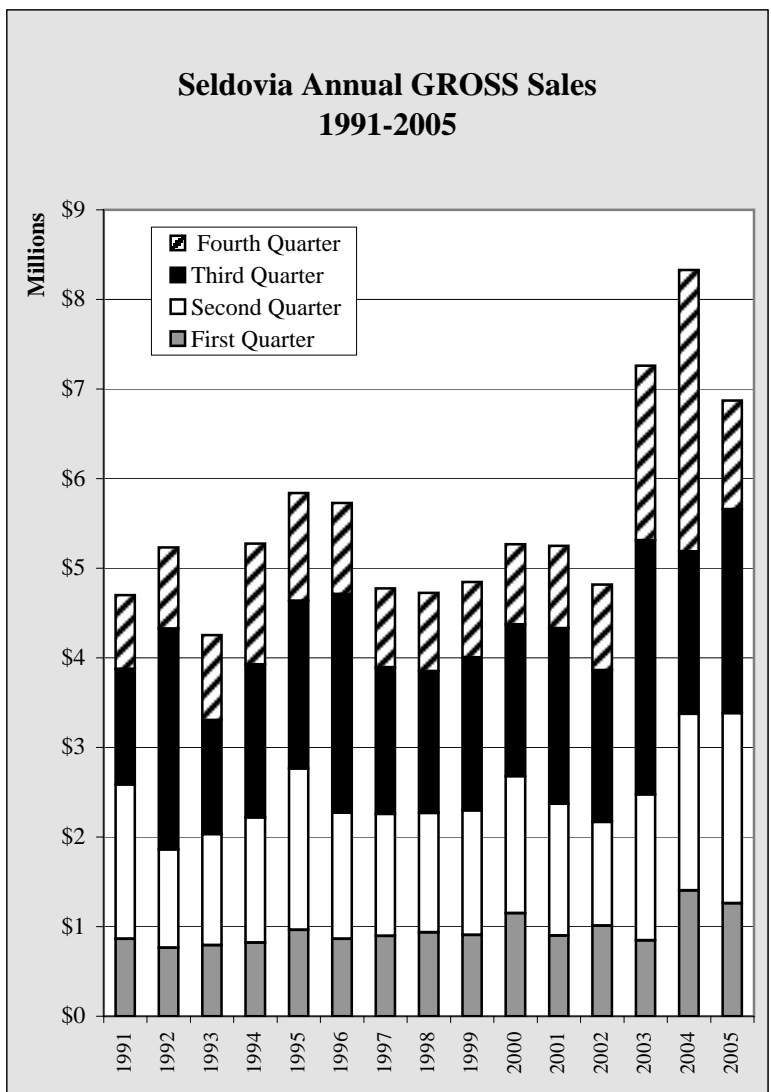

Chart 4.10

Seldovia Sales

Seldovia Annual TAXABLE Sales by Industry - 2000-2005 - in \$							
	2000	2001	2002	2003	2004	2005	Annual Change
Ag, Forestry, Fishing	2,771	3,616	3,551	2,970	3,140	0	-100.0%
Mining	0	0	0	0	0	0	NA
Construction	41,098	34,175	22,683	26,848	27,088	23,768	-12.3%
Manufacturing	4,892	4,818	6,509	9,098	9,146	13,744	50.3%
Tran, Comm, Pub Util	455,499	410,584	427,667	450,291	411,317	445,007	8.2%
Wholesale	4,692	4,069	945	1,649	426	207	-51.4%
Retail	2,165,560	2,226,879	2,118,927	2,155,556	2,167,989	2,155,986	-0.6%
Finance, Ins, Real Estate	28,771	31,657	24,937	29,796	47,940	52,484	9.5%
Service	714,840	643,481	667,170	700,736	719,266	689,400	-4.2%
Total	3,418,123	3,359,279	3,272,389	3,376,944	3,386,312	3,380,596	-0.2%
Annual Change		-1.7%	-2.6%	3.2%	0.3%	-0.2%	

Table 4.6

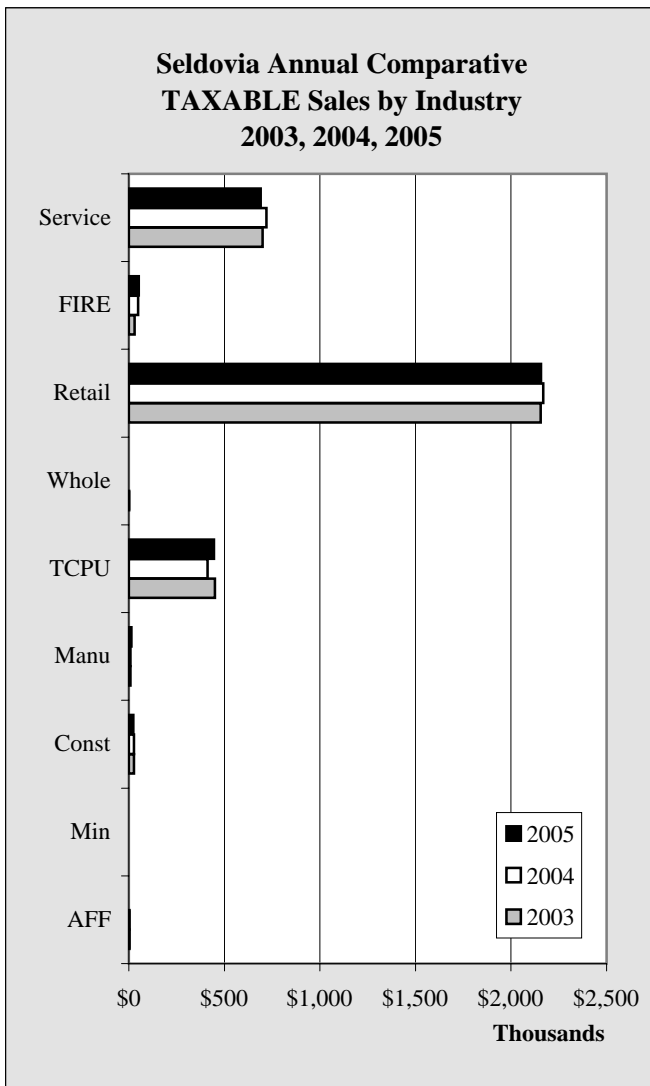

Chart 4.11

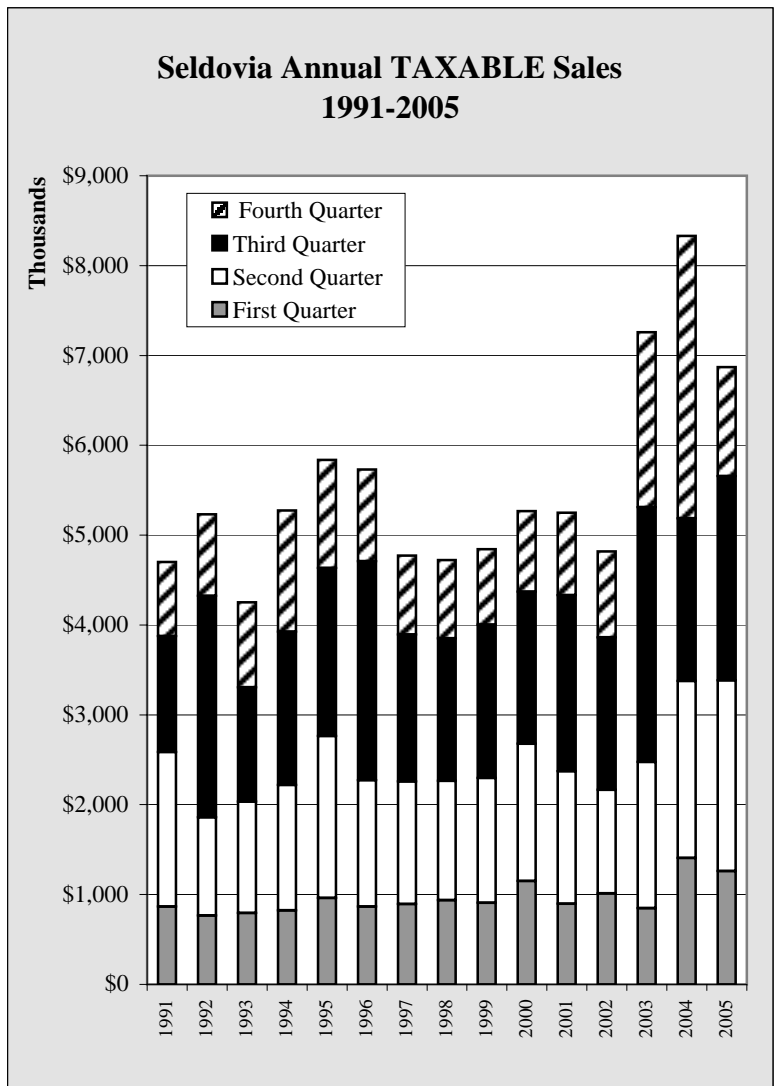

Chart 4.12

Seldovia Sales

Seldovia GROSS Sales by Industry by Quarter - 2003-2006 - in \$					
	1st Quarter	2nd Quarter	3rd Quarter	4th Quarter	Total
2003					
Ag, Forestry, Fishing	0	5,737	0	0	5,737
Mining	0	0	0	0	0
Construction	27,947	213,775	1,256,705	736,642	2,235,069
Manufacturing	1,845	25,326	14,320	2,645	44,136
Trans, Comm, Pub Util	147,749	135,580	137,236	188,812	609,377
Wholesale	9,201	17,477	71,441	45,855	143,974
Retail	544,320	711,358	768,860	540,761	2,565,299
Finance, Ins, Real Estate	7,090	242,188	91,073	250,503	590,854
Services	108,853	278,014	494,150	184,091	1,065,108
Total	847,005	1,629,455	2,833,785	1,949,309	7,259,554
2004					
Ag, Forestry, Fishing	0	11,260	17,500	0	28,760
Mining	0	0	0	0	0
Construction	601,376	763,635	360,893	706,248	2,432,152
Manufacturing	1,249	8,735	12,786	1,793	24,563
Trans, Comm, Pub Util	151,748	152,078	168,520	149,278	621,624
Wholesale	14,150	26,237	30,407	34,554	105,348
Retail	522,637	722,686	762,079	633,400	2,640,802
Finance, Ins, Real Estate	9,127	10,170	14,447	1,417,048	1,450,792
Services	104,760	276,869	442,435	201,726	1,025,790
Total	1,405,047	1,971,670	1,809,067	3,144,047	8,329,831
2005					
Ag, Forestry, Fishing	0	0	0	0	0
Mining	0	0	0	0	0
Construction	434,659	412,463	443,920	65,780	1,356,822
Manufacturing	1,331	36,891	41,998	71,102	151,322
Trans, Comm, Pub Util	160,989	177,421	172,674	179,116	690,200
Wholesale	12,898	35,271	20,608	22,208	90,985
Retail	533,324	745,371	899,747	597,218	2,775,660
Finance, Ins, Real Estate	16,009	424,120	239,994	131,897	812,020
Services	102,525	288,997	456,010	145,151	992,683
Total	1,261,735	2,120,534	2,274,951	1,212,472	6,869,692
2006					
	Year to Date				
Ag, Forestry, Fishing	0	0			0
Mining	0	0			0
Construction	101,738	136,390			238,128
Manufacturing	19,854	33,668			53,522
Trans, Comm, Pub Util	229,776	221,184			450,960
Wholesale	10,997	34,949			45,946
Retail	590,084	806,094			1,396,178
Finance, Ins, Real Estate	424,841	579,537			1,004,378
Services	138,948	327,989			466,937
Total	1,516,238	2,139,811	0	0	3,656,049

Table 4.7

Seldovia Sales

Seldovia TAXABLE Sales by Industry by Quarter - 2003-2006 - in \$					
	1st Quarter	2nd Quarter	3rd Quarter	4th Quarter	Total
2003					
Ag, Forestry, Fishing	0	2,970	0	0	2,970
Mining	0	0	0	0	0
Construction	1,131	9,946	6,900	8,871	26,848
Manufacturing	368	1,749	6,036	945	9,098
Trans, Comm, Pub Util	103,692	96,701	107,036	142,862	450,291
Wholesale	150	321	640	538	1,649
Retail	415,056	620,851	693,503	426,146	2,155,556
Finance, Ins, Real Estate	4,600	9,430	7,783	7,983	29,796
Services	73,973	220,998	318,421	87,344	700,736
Total	598,970	962,966	1,140,319	674,689	3,376,944
2004					
Ag, Forestry, Fishing	0	3,140	0	0	3,140
Mining	0	0	0	0	0
Construction	5,160	8,058	7,520	6,350	27,088
Manufacturing	649	2,135	4,964	1,398	9,146
Trans, Comm, Pub Util	96,989	105,084	118,010	91,234	411,317
Wholesale	30	137	131	128	426
Retail	392,241	613,360	698,936	463,452	2,167,989
Finance, Ins, Real Estate	5,942	8,540	10,589	22,869	47,940
Services	65,715	199,135	341,988	112,428	719,266
Total	566,726	939,589	1,182,138	697,859	3,386,312
2005					
Ag, Forestry, Fishing	0	0	0	0	0
Mining	0	0	0	0	0
Construction	4,655	5,615	5,866	7,632	23,768
Manufacturing	831	2,819	5,922	4,172	13,744
Trans, Comm, Pub Util	102,157	108,937	113,982	119,931	445,007
Wholesale	75	51	81	0	207
Retail	390,012	591,323	743,682	430,969	2,155,986
Finance, Ins, Real Estate	11,204	10,740	18,433	12,107	52,484
Services	64,083	212,656	327,326	85,335	689,400
Total	573,017	932,141	1,215,292	660,146	3,380,596
2006					
	Year to Date				
Ag, Forestry, Fishing	0	0			0
Mining	0	0			0
Construction	6,365	6,858			13,223
Manufacturing	3,502	4,421			7,923
Trans, Comm, Pub Util	121,663	113,771			235,434
Wholesale	75	216			291
Retail	393,195	653,897			1,047,092
Finance, Ins, Real Estate	15,443	14,257			29,700
Services	95,569	150,079			245,648
Total	635,812	943,499	0	0	1,579,311

Table 4.8

Seldovia Construction

Seldovia 2nd Quarter Permit VALUES by Type - 2000-2006 - in \$

	2000	2001	2002	2003	2004	2005	2006	Annual Change
Residential - New	8,000	25,000	0	0	150,000	300,000	55,000	-81.7%
Residential - Add/Alter	14,300	0	8,000	0	6,200	4,000	32,000	700.0%
Commercial - New	0	0	0	0	0	8,000	0	-100.0%
Commercial - Add/Alter	0	0	0	0	0	154,000	0	-100.0%
TOTAL	22,300	25,000	8,000	0	156,200	466,000	87,000	-81.3%
Annual Change		12.1%	-68.0%	-100.0%	NA	198.3%	-81.3%	

Table 4.9

Seldovia 2nd Quarter Permit VOLUME by Type - 2000-2006

	2000	2001	2002	2003	2004	2005	2006	Annual Change
Residential - New	2	1	0	0	1	2	2	0.0%
Residential - Add/Alter	1	0	2	0	2	1	3	200.0%
Commercial - New	0	0	0	0	0	1	0	-100.0%
Commercial - Add/Alter	0	0	0	0	0	2	1	-50.0%
TOTAL	3	1	2	0	3	6	6	0.0%
Annual Change		-66.7%	100.0%	-100.0%	NA	100.0%	0.0%	

Table 4.10

Seldovia 2nd Quarter Permit VALUES by Type - 1986-2006

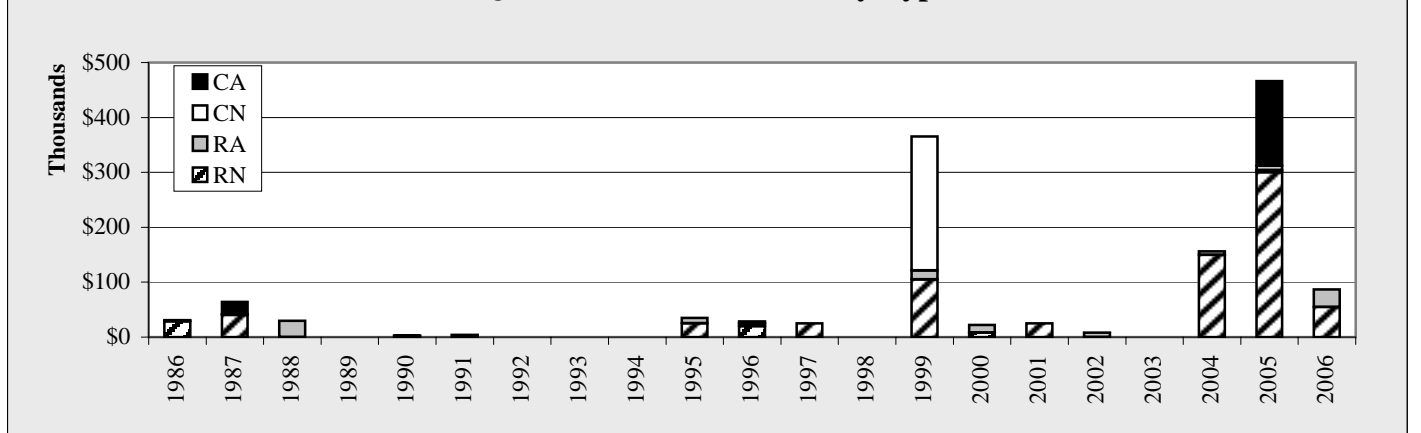

Chart 4.13

Seldovia 2nd Quarter Permit VOLUME by Type - 1986-2006

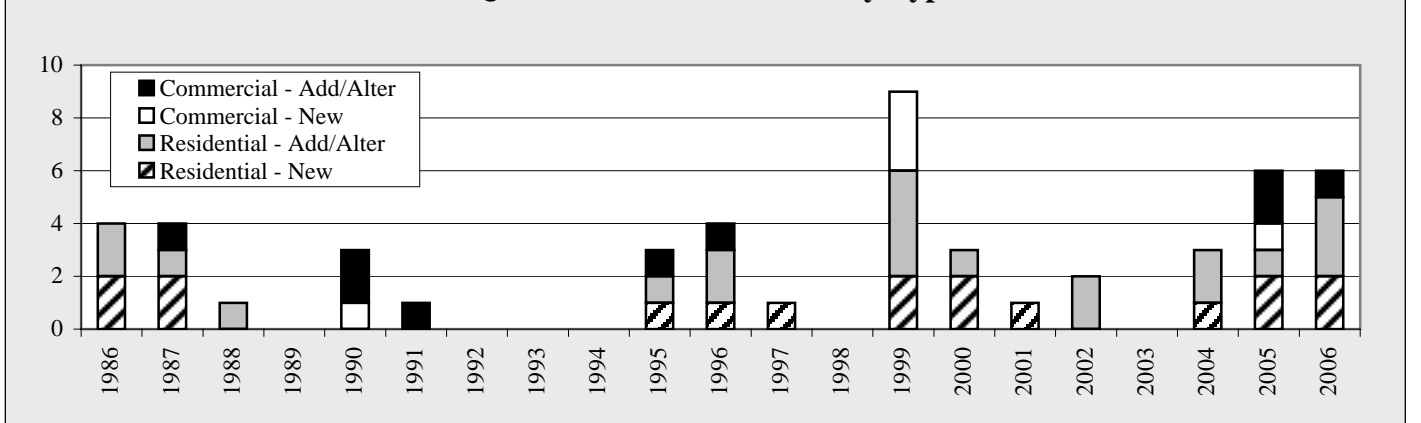

Chart 4.14

Seldovia Construction

Seldovia YTD 6/30 Permit VALUES by Type - 2000-2006 - in \$

	2000	2001	2002	2003	2004	2005	2006	Annual Change
Residential - New	26,000	25,000	0	0	170,000	300,000	85,000	-71.7%
Residential - Add/Alter	20,300	0	18,000	31,000	6,200	19,000	32,000	68.4%
Commercial - New	0	0	0	0	0	8,000	0	-100.0%
Commercial - Add/Alter	0	10,000	0	0	0	154,000	0	-100.0%
TOTAL	46,300	35,000	18,000	31,000	176,200	481,000	117,000	-75.7%
Annual Change		-24.4%	-48.6%	72.2%	468.4%	173.0%	-75.7%	

Table 4.11

Seldovia YTD 6/30 Permit VOLUME by Type - 2000-2006

	2000	2001	2002	2003	2004	2005	2006	Annual Change
Residential - New	4	1	0	0	2	2	3	50.0%
Residential - Add/Alter	2	0	3	3	2	2	3	50.0%
Commercial - New	0	0	0	0	0	1	0	-100.0%
Commercial - Add/Alter	0	1	0	0	0	2	1	-50.0%
TOTAL	6	2	3	3	4	7	7	0.0%
Annual Change		-66.7%	50.0%	0.0%	33.3%	75.0%	0.0%	

Table 4.12

Seldovia YTD 6/30 Permit VALUES by Type - 1986-2006

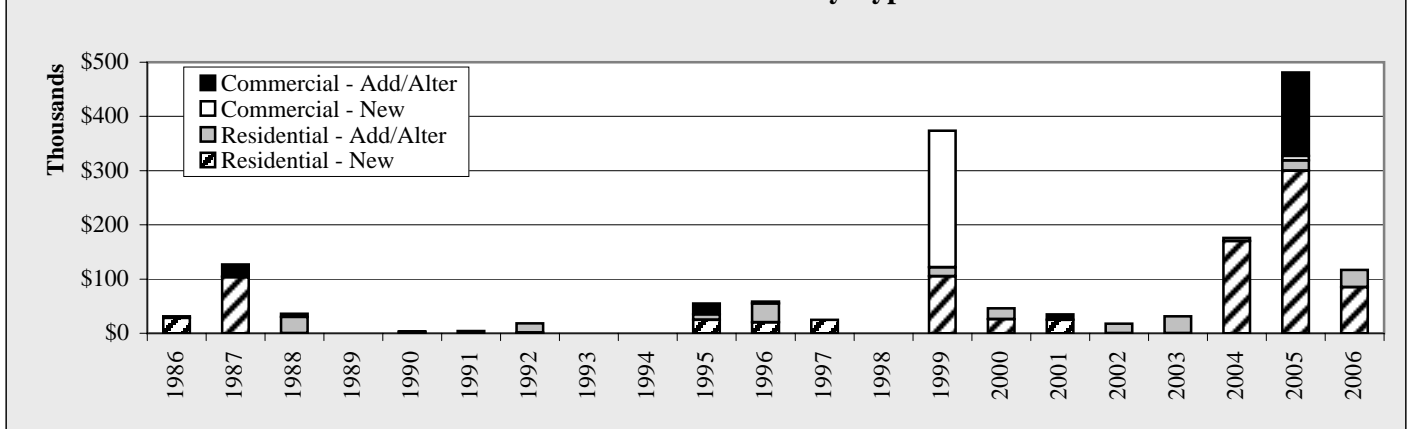

Chart 4.15

Seldovia YTD 6/30 Permit VOLUME by Type - 1986-2006

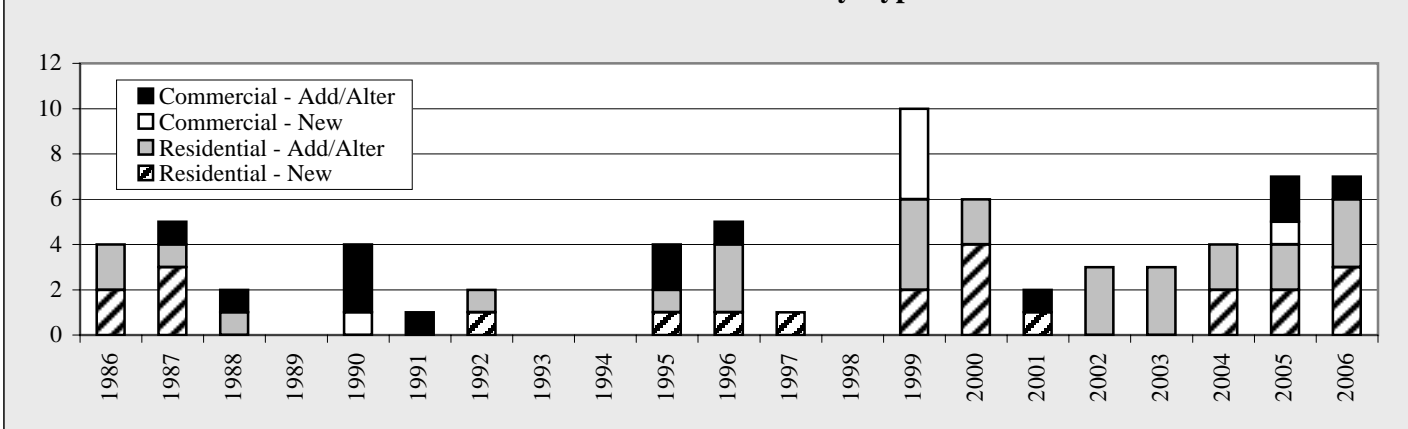

Chart 4.16

Seldovia Construction

Seldovia Annual Permit VALUES by Type by Quarter - 2000-2006 - in \$					
	1st Quarter	2nd Quarter	3rd Quarter	4th Quarter	Total
2000					
Residential - New	18,000	8,000	19,000	0	45,000
Residential - Add/Alter	6,000	14,300	35,400	5,000	60,700
Commercial - New	0	0	0	0	0
Commercial - Add/Alter	0	0	3,500	0	3,500
TOTAL	24,000	22,300	57,900	5,000	109,200
2001					
Residential - New	0	25,000	10,000	0	35,000
Residential - Add/Alter	0	0	5,525	5,000	10,525
Commercial - New	0	0	0	0	0
Commercial - Add/Alter	10,000	0	0	10,000	20,000
TOTAL	10,000	25,000	15,525	15,000	65,525
2002					
Residential - New	0	0	308,000	0	308,000
Residential - Add/Alter	10,000	8,000	10,500	20,000	48,500
Commercial - New	0	0	0	0	0
Commercial - Add/Alter	0	0	0	0	0
TOTAL	10,000	8,000	318,500	20,000	356,500
2003					
Residential - New	0	0	150,000	26,000	176,000
Residential - Add/Alter	31,000	0	0	3,000	34,000
Commercial - New	0	0	1,685,000	7,500	1,692,500
Commercial - Add/Alter	0	0	0	0	0
TOTAL	31,000	0	1,835,000	36,500	1,902,500
2004					
Residential - New	20,000	150,000	0	0	170,000
Residential - Add/Alter	0	6,200	0	0	6,200
Commercial - New	0	0	0	0	0
Commercial - Add/Alter	0	0	0	0	0
TOTAL	20,000	156,200	0	0	176,200
2005					
Residential - New	0	300,000	0	0	300,000
Residential - Add/Alter	15,000	4,000	30,000	0	49,000
Commercial - New	0	8,000	0	0	8,000
Commercial - Add/Alter	0	154,000	500	500	155,000
TOTAL	15,000	466,000	30,500	500	512,000
2006					
	Year to Date				
Residential - New	30,000	55,000			85,000
Residential - Add/Alter	0	32,000			32,000
Commercial - New	0	0			0
Commercial - Add/Alter	0	0			0
TOTAL	30,000	87,000			117,000

Table 4.13

Seldovia Construction

Seldovia Annual Permit VOLUME by Type by Quarter - 2000-2006					
	1st Quarter	2nd Quarter	3rd Quarter	4th Quarter	Total
2000					
Residential - New	2	2	2	0	6
Residential - Add/Alter	1	1	3	1	6
Commercial - New	0	0	0	0	0
Commercial - Add/Alter	0	0	1	0	1
TOTAL	3	3	6	1	13
2001					
Residential - New	0	1	1	0	2
Residential Add/Alter	0	0	4	1	5
Commercial - New	0	0	0	0	0
Commercial - Add/Alter	1	0	0	1	2
TOTAL	1	1	5	2	9
2002					
Residential - New	0	0	2	0	2
Residential Add/Alter	1	2	2	1	6
Commercial - New	0	0	0	0	0
Commercial - Add/Alter	0	0	0	0	0
TOTAL	1	2	4	1	8
2003					
Residential - New	0	0	1	2	3
Residential Add/Alter	3	0	0	1	4
Commercial - New	0	0	3	1	4
Commercial - Add/Alter	0	0	1	0	1
TOTAL	3	0	5	4	12
2004					
Residential - New	1	1	0	0	2
Residential Add/Alter	0	2	0	0	2
Commercial - New	0	0	0	0	0
Commercial - Add/Alter	0	0	0	0	0
TOTAL	1	3	0	0	4
2005					
Residential - New	0	2	0	0	2
Residential Add/Alter	1	1	1	0	3
Commercial - New	0	1	0	0	1
Commercial - Add/Alter	0	2	1	1	4
TOTAL	1	6	2	1	10
2006					
	Year to Date				
Residential - New	1	2			3
Residential Add/Alter	0	3			3
Commercial - New	0	0			0
Commercial - Add/Alter	0	1			1
TOTAL	1	6			7

Table 4.14

Seward Sales

Seward 2nd Quarter GROSS Sales by Industry - 2001-2006 - in \$							
	2001	2002	2003	2004	2005	2006	Annual Change
Ag, Forestry, Fish	170,823	153,308	180,817	271,027	288,152	336,826	16.9%
Mining	105,401	131,150	49,589	78,789	67,545	96	-99.9%
Construction	8,043,831	2,360,200	10,116,956	4,487,357	17,079,764	7,701,990	-54.9%
Manufacturing	3,697,117	3,261,062	3,785,614	1,922,115	2,259,050	1,965,980	-13.0%
Trans, Comm, Pub Util	3,524,903	3,404,989	3,313,681	3,233,313	3,295,999	3,567,681	8.2%
Wholesale	671,328	671,893	682,756	910,240	1,102,893	1,034,842	-6.2%
Retail	15,137,856	15,310,055	14,977,089	17,943,071	19,675,345	20,929,871	6.4%
Finance, Ins, Real Estate	1,147,228	2,349,136	2,106,421	1,663,066	1,961,475	1,087,987	-44.5%
Services	11,953,791	12,743,583	11,771,230	12,240,294	12,737,048	12,960,158	1.8%
Government	0	0	0	0	0	0	NA
Total	44,452,278	40,385,376	46,984,153	42,749,272	58,467,271	49,585,431	-15.2%
Annual Change		-9.1%	16.3%	-9.0%	36.8%	-15.2%	

Table 5.1

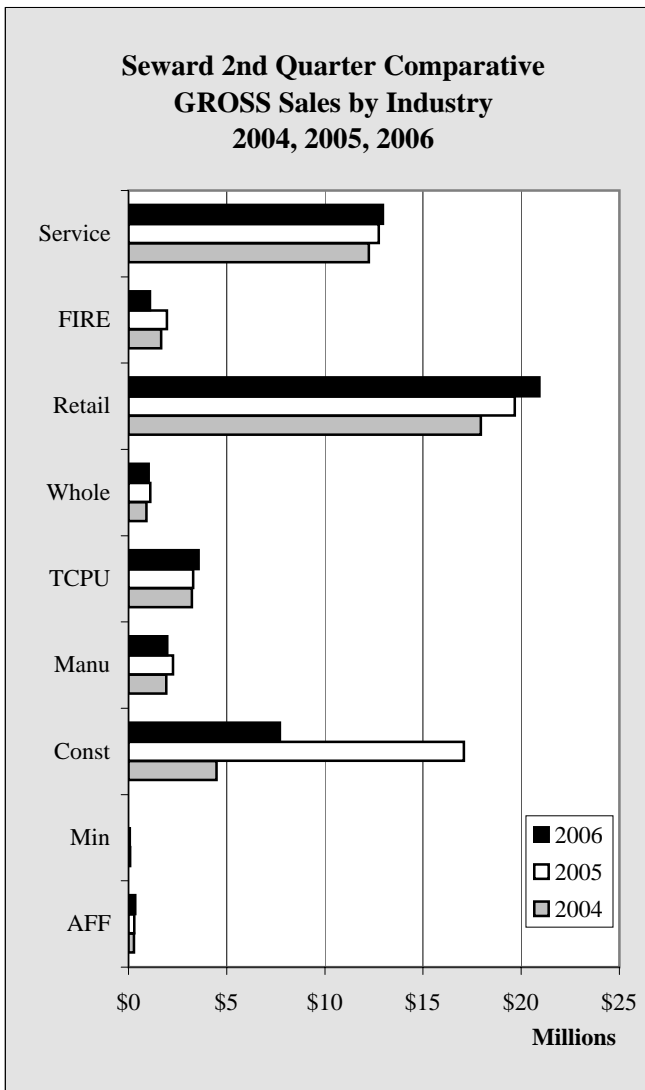

Chart 5.1

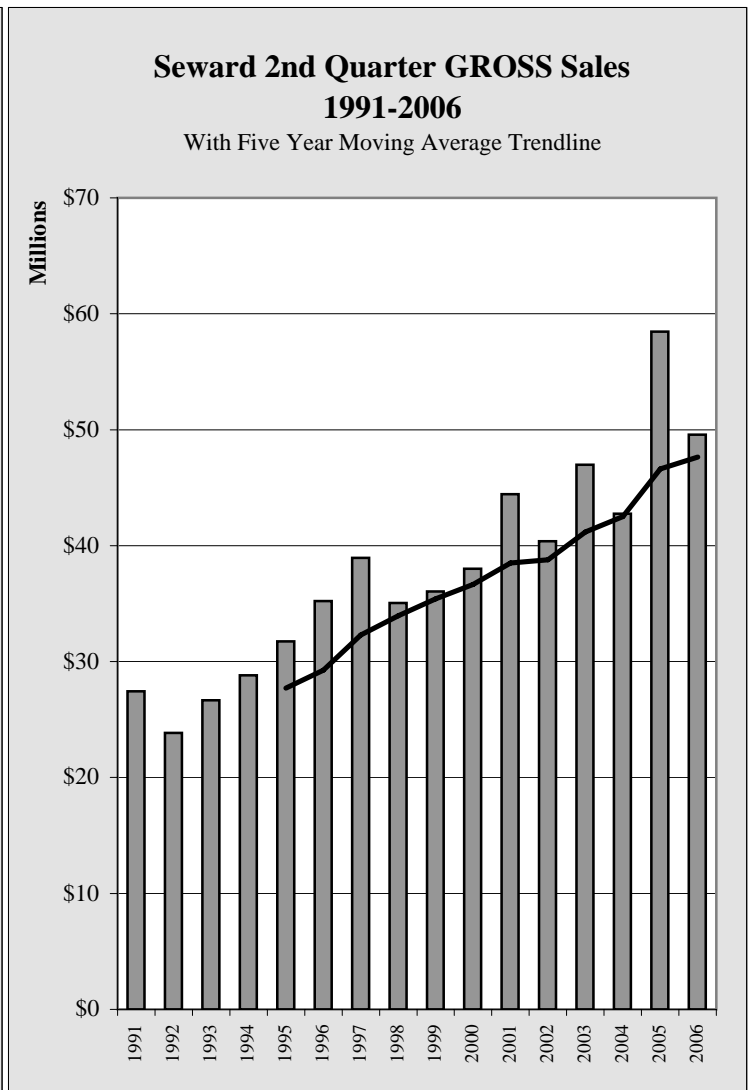

Chart 5.2

Seward Sales

Seward 2nd Quarter TAXABLE Sales by Industry - 2001-2006 - in \$							
	2001	2002	2003	2004	2005	2006	Annual Change
Ag, Forestry, Fish	69,770	57,747	70,505	77,870	87,792	65,204	-25.7%
Mining	0	0	1,754	0	0	96	NA
Construction	160,218	140,758	190,057	198,782	215,539	191,709	-11.1%
Manufacturing	312,269	299,221	157,138	162,634	135,184	178,635	32.1%
Trans, Comm, Pub Util	795,756	780,744	806,530	758,614	789,089	750,338	-4.9%
Wholesale	41,804	38,741	40,058	34,969	34,511	36,432	5.6%
Retail	10,866,501	11,179,774	11,465,828	11,956,679	13,617,744	14,202,308	4.3%
Finance, Ins, Real Estate	433,701	488,696	415,752	394,778	470,933	450,786	-4.3%
Services	8,873,245	9,190,793	8,924,459	9,407,577	10,016,817	10,485,986	4.7%
Government	0	0	0	0	0	0	NA
Total	21,553,264	22,176,474	22,072,081	22,991,903	25,367,609	26,361,494	3.9%
Annual Change		2.9%	-0.5%	4.2%	10.3%	3.9%	

Table 5.2

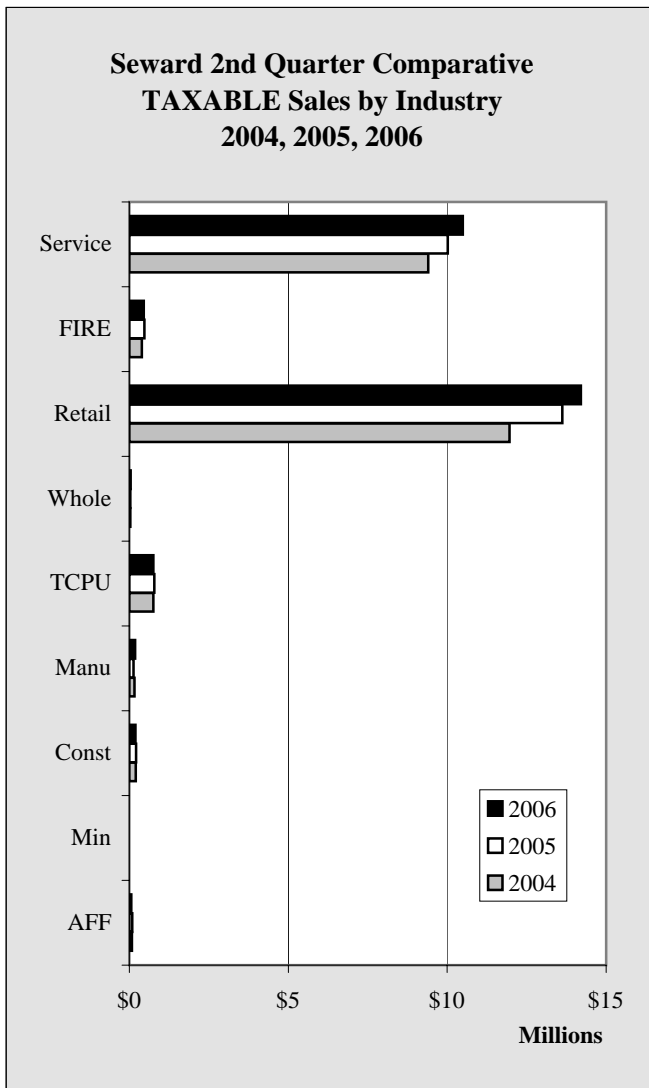

Chart 5.3

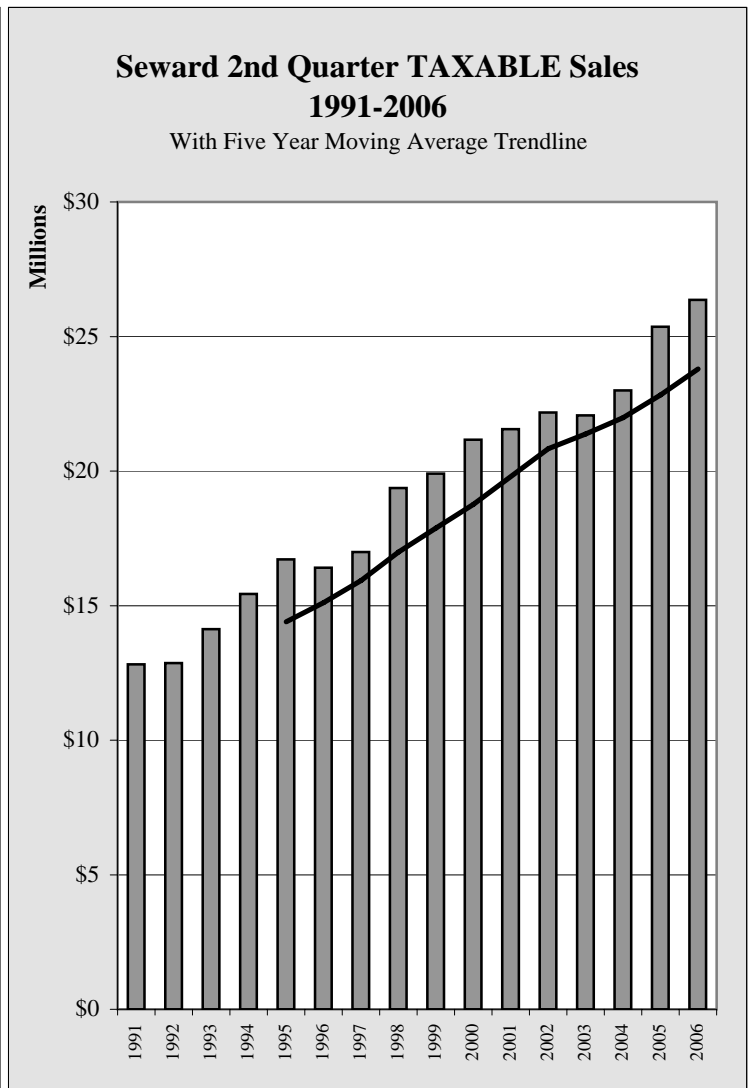

Chart 5.4

Seward Sales

Seward YTD 6/30 GROSS Sales by Industry - 2001-2006 - in \$							
	2001	2002	2003	2004	2005	2006	Annual Change
Ag, Forestry, Fish	198,348	174,118	216,267	325,576	318,941	482,944	51.4%
Mining	169,292	180,102	117,510	103,785	100,192	124	-99.9%
Construction	11,908,839	5,400,564	13,518,410	7,794,119	25,194,479	9,628,345	-61.8%
Manufacturing	6,012,064	5,235,668	5,253,891	2,814,701	3,213,655	2,628,822	-18.2%
Trans, Comm, Pub Util	5,846,878	5,658,092	5,398,582	5,825,755	6,041,655	5,706,890	-5.5%
Wholesale	1,032,783	1,058,790	1,067,835	1,454,888	1,623,636	1,464,704	-9.8%
Retail	22,110,814	23,242,276	22,775,722	26,568,352	28,776,002	31,684,537	10.1%
Finance, Ins, Real Estate	2,236,658	4,139,761	3,500,580	3,070,109	3,064,474	2,742,766	-10.5%
Services	15,467,874	18,250,018	16,070,540	15,967,276	16,603,070	16,886,828	1.7%
Government	0	0	0	0	0	0	NA
Total	64,983,550	63,339,389	67,919,337	63,924,561	84,936,104	71,225,960	-16.1%
Annual Change		-2.5%	7.2%	-5.9%	32.9%	-16.1%	

Table 5.3

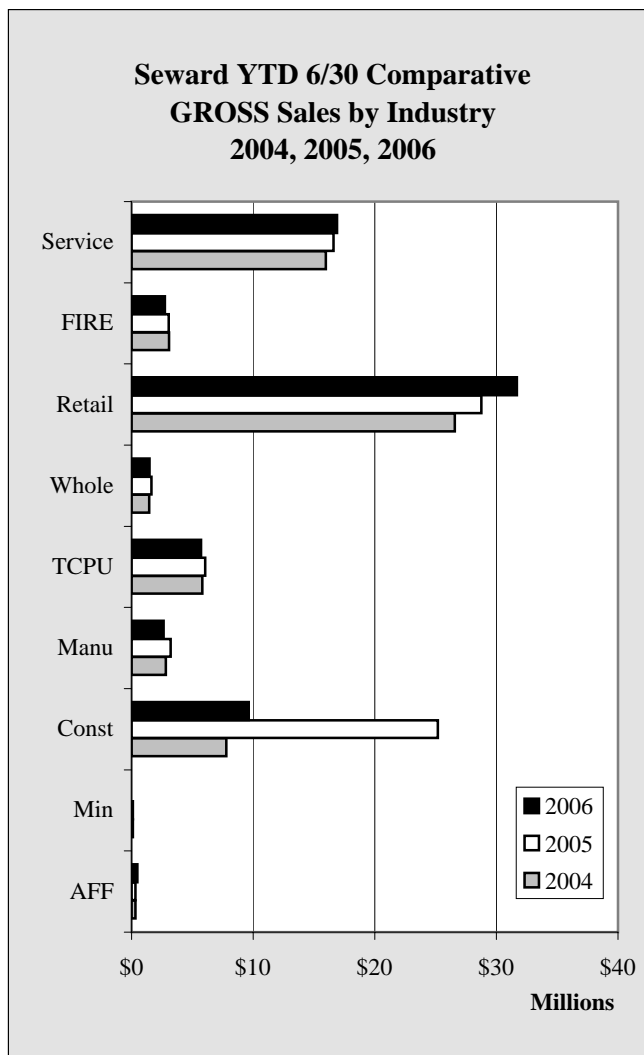

Chart 5.5

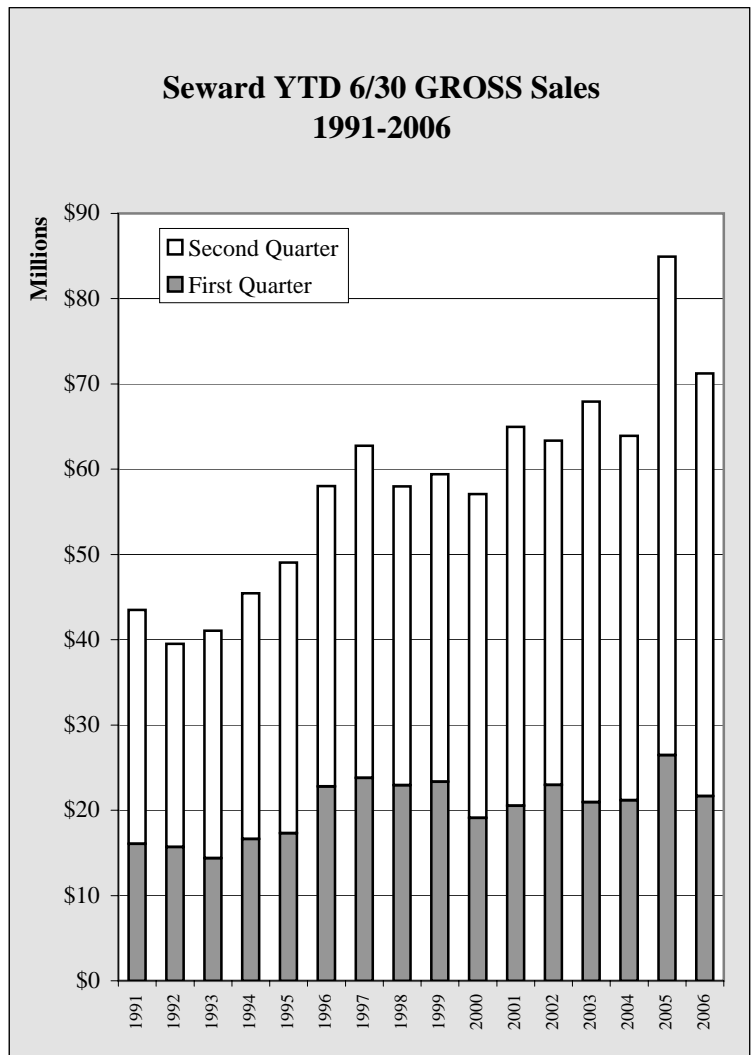

Chart 5.6

Seward Sales

Seward YTD 6/30 TAXABLE Sales by Industry - 2001-2006 - in \$							
	2001	2002	2003	2004	2005	2006	Annual Change
Ag, Forestry, Fish	73,760	64,476	82,178	89,793	96,281	76,869	-20.2%
Mining	0	0	1,754	0	0	124	NA
Construction	290,284	269,565	316,931	366,212	375,702	350,996	-6.6%
Manufacturing	437,079	415,022	301,991	294,260	222,362	271,874	22.3%
Trans, Comm, Pub Util	1,448,530	1,341,601	1,394,995	1,340,392	1,377,137	1,329,178	-3.5%
Wholesale	71,113	50,767	55,355	58,442	49,045	47,364	-3.4%
Retail	16,192,627	16,567,714	17,066,590	17,791,488	19,998,695	20,740,468	3.7%
Finance, Ins, Real Estate	797,533	843,326	745,821	690,476	755,872	758,429	0.3%
Services	11,315,831	11,675,047	11,390,970	11,855,604	12,583,500	12,948,156	2.9%
Government	0	0	0	0	0	0	NA
Total	30,626,757	31,227,518	31,356,585	32,486,667	35,458,594	36,523,458	3.0%
Annual Change		2.0%	0.4%	3.6%	9.1%	3.0%	

Table 5.4

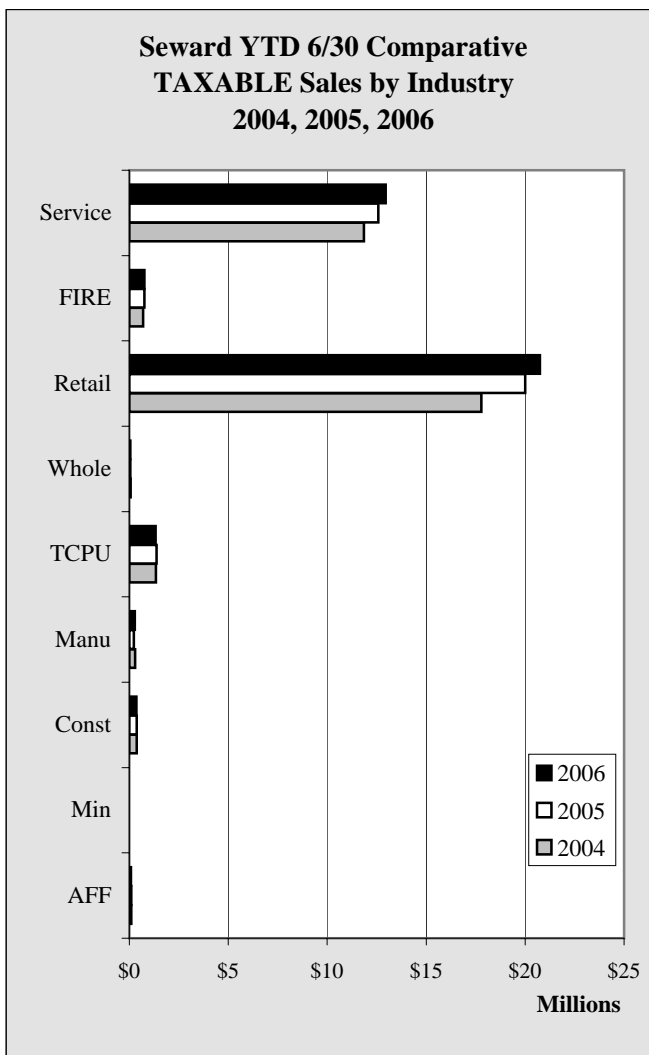

Chart 5.7

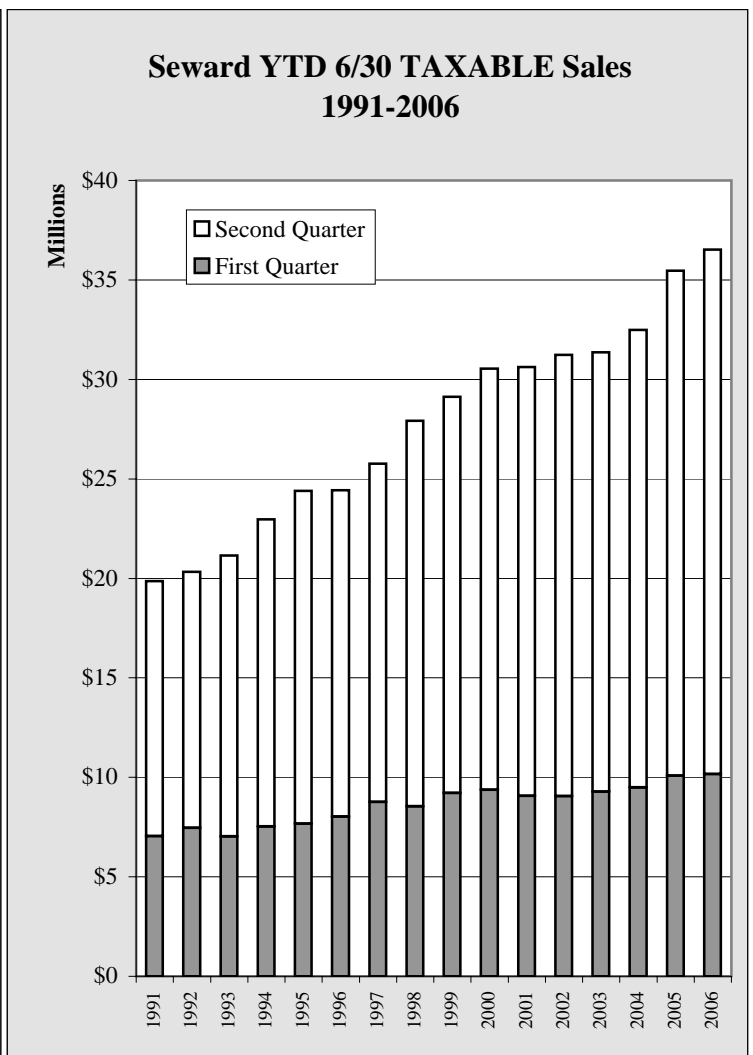

Chart 5.8

Seward Sales

Seward Annual GROSS Sales by Industry - 2000-2005 - in \$							
	2000	2001	2002	2003	2004	2005	Annual Change
Ag, Forestry, Fish	689,481	437,640	298,046	489,097	651,718	1,621,779	148.8%
Mining	405,115	330,859	377,441	189,755	228,403	227,768	-0.3%
Construction	16,255,816	21,082,426	11,078,244	28,881,212	31,492,128	40,895,792	29.9%
Manufacturing	9,541,307	12,023,577	11,540,635	10,446,881	7,214,583	8,277,985	14.7%
Trans, Comm, Pub Util	14,705,875	12,840,952	13,026,323	12,969,855	11,702,893	13,031,624	11.4%
Wholesale	2,339,175	2,231,731	2,208,659	2,600,579	3,953,585	4,929,868	24.7%
Retail	51,460,505	50,408,318	52,600,754	53,594,945	60,076,596	66,613,385	10.9%
Finance, Ins, Real Estate	8,394,110	6,333,381	7,601,886	7,557,129	7,207,271	7,762,127	7.7%
Services	38,360,895	42,671,669	43,637,638	40,232,483	43,669,518	45,919,985	5.2%
Government	0	0	0	0	0	0	NA
Total	142,152,279	148,360,553	142,369,626	156,961,936	166,196,695	189,280,313	13.9%
Annual Change		4.4%	-4.0%	10.2%	5.9%	13.9%	

Table 5.5

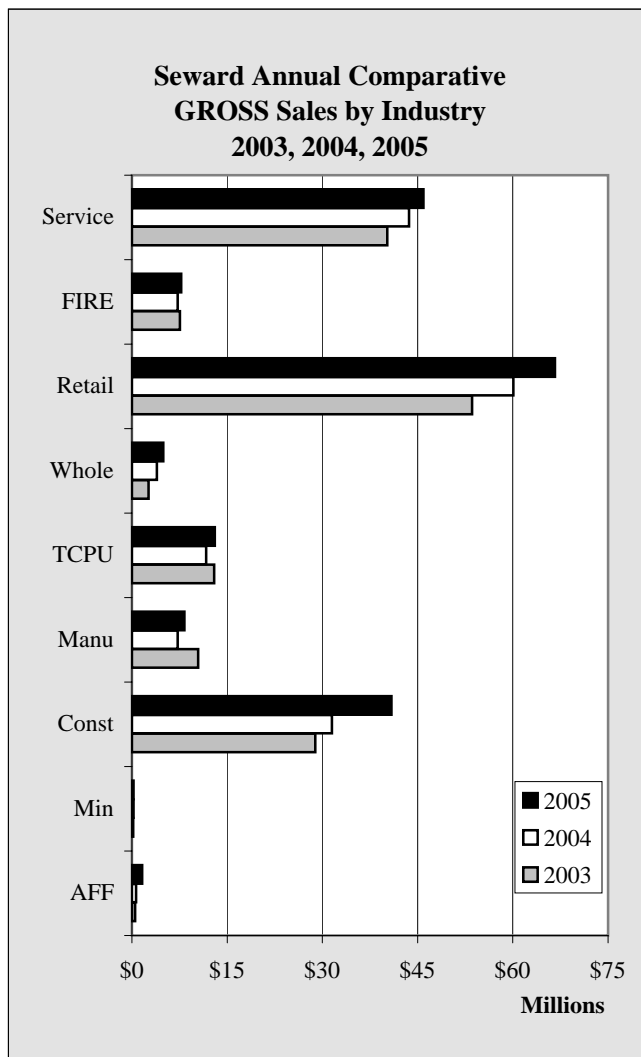

Chart 5.9

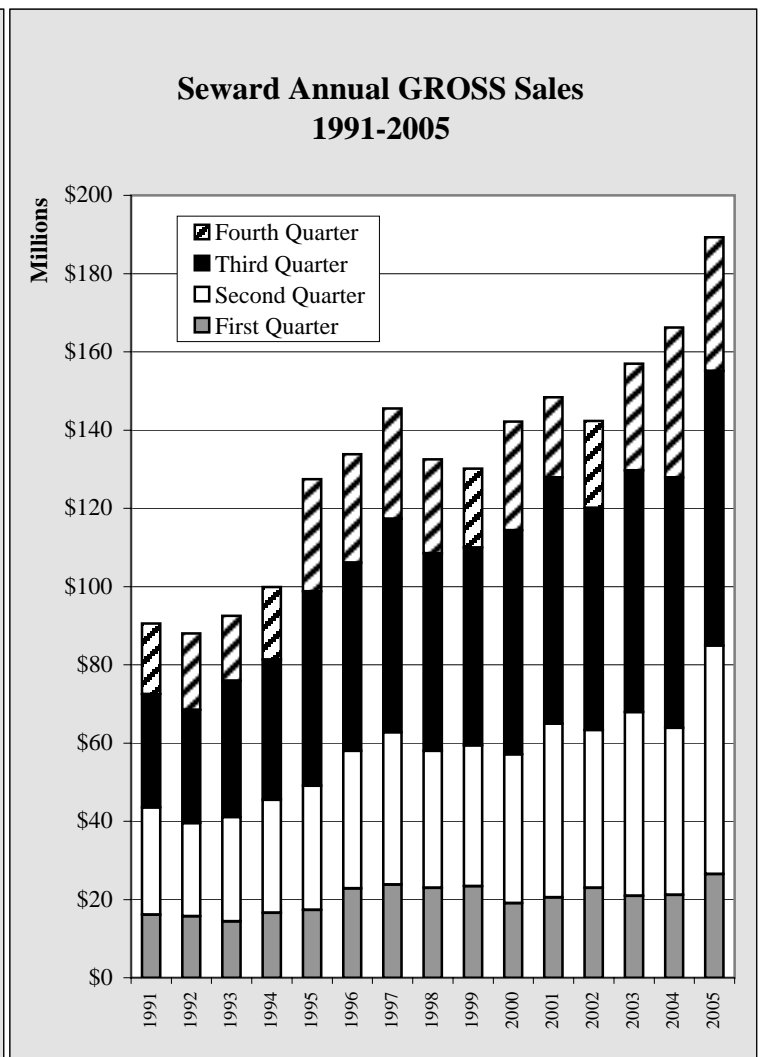

Chart 5.10

Seward Sales

Seward Annual TAXABLE Sales by Industry - 2000-2005 - in \$							
	2000	2001	2002	2003	2004	2005	Annual Change
Ag, Forestry, Fish	240,141	170,624	114,521	217,323	227,337	254,646	12.0%
Mining	500	0	0	3,455	0	0	NA
Construction	671,326	567,626	564,790	683,590	739,180	707,124	-4.3%
Manufacturing	639,366	962,382	988,659	629,648	605,028	497,210	-17.8%
Trans, Comm, Pub Util	3,991,338	2,936,725	2,916,215	2,921,669	2,853,456	3,109,097	9.0%
Wholesale	141,551	135,396	107,027	119,020	107,918	107,085	-0.8%
Retail	37,600,377	38,191,615	39,040,960	40,272,089	42,443,807	47,876,966	12.8%
Finance, Ins, Real Estate	1,583,364	1,665,703	1,781,096	1,593,083	1,583,071	1,761,644	11.3%
Services	29,115,463	29,595,520	30,077,454	29,908,856	31,387,164	33,689,987	7.3%
Government	0	0	0	0	0	0	NA
Total	73,983,426	74,225,591	75,590,722	76,348,733	79,946,961	88,003,759	10.1%
Annual Change		0.3%	1.8%	1.0%	4.7%	10.1%	

Table 5.6

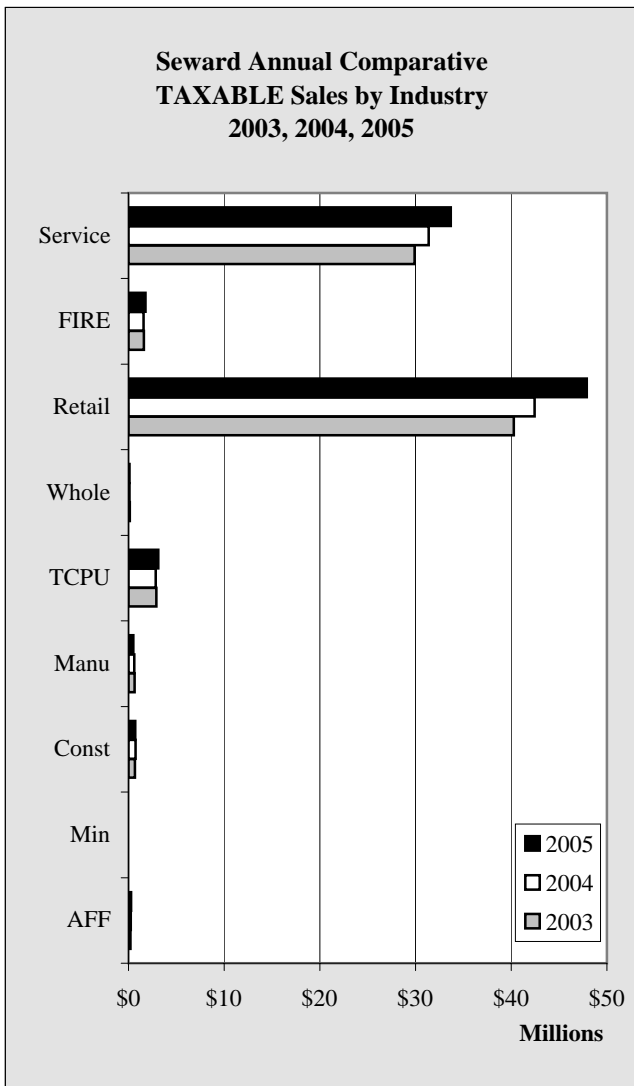

Chart 5.11

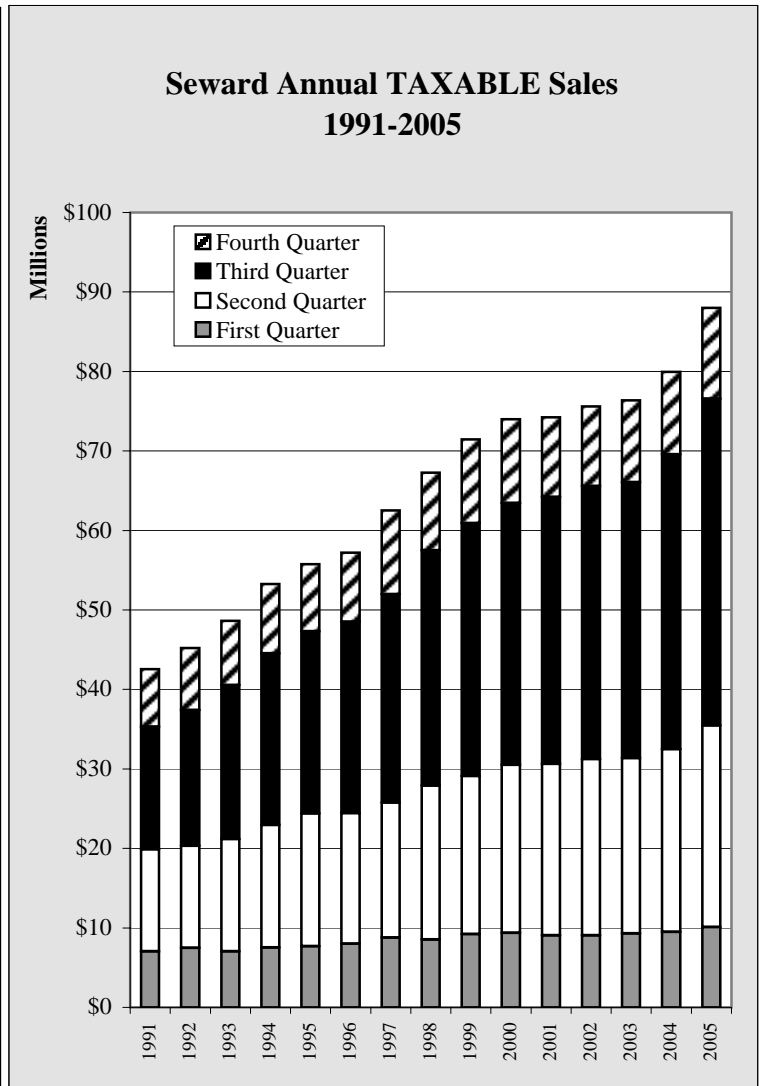

Chart 5.12

Seward Sales

Seward GROSS Sales by Industry by Quarter - 2003-2006 - in \$					
	1st Quarter	2nd Quarter	3rd Quarter	4th Quarter	Total
2003					
Ag, Forestry, Fish	35,450	180,817	233,386	39,444	489,097
Mining	67,921	49,589	49,094	23,151	189,755
Construction	3,401,454	10,116,956	9,666,381	5,696,421	28,881,212
Manufacturing	1,468,277	3,785,614	2,466,178	2,726,812	10,446,881
Trans, Comm, Pub Util	2,084,901	3,313,681	5,201,510	2,369,763	12,969,855
Wholesale	385,079	682,756	888,555	644,189	2,600,579
Retail	7,798,633	14,977,089	21,297,449	9,521,774	53,594,945
Finance, Ins, Real Estate	1,394,159	2,106,421	2,068,760	1,987,789	7,557,129
Services	4,299,310	11,771,230	19,836,872	4,325,071	40,232,483
Government	0	0	0	0	0
Total	20,935,184	46,984,153	61,708,185	27,334,414	156,961,936
2004					
Ag, Forestry, Fish	54,549	271,027	248,373	77,769	651,718
Mining	24,996	78,789	89,202	35,416	228,403
Construction	3,306,762	4,487,357	6,884,443	16,813,566	31,492,128
Manufacturing	892,586	1,922,115	3,515,011	884,871	7,214,583
Trans, Comm, Pub Util	2,592,442	3,233,313	3,570,845	2,306,293	11,702,893
Wholesale	544,648	910,240	1,199,749	1,298,948	3,953,585
Retail	8,625,281	17,943,071	24,148,081	9,360,163	60,076,596
Finance, Ins, Real Estate	1,407,043	1,663,066	2,516,118	1,621,044	7,207,271
Services	3,726,982	12,240,294	21,739,336	5,962,906	43,669,518
Government	0	0	0	0	0
Total	21,175,289	42,749,272	63,911,158	38,360,976	166,196,695
2005					
Ag, Forestry, Fish	30,789	288,152	1,058,218	244,620	1,621,779
Mining	32,647	67,545	127,576	0	227,768
Construction	8,114,715	17,079,764	7,563,667	8,137,646	40,895,792
Manufacturing	954,605	2,259,050	3,019,875	2,044,455	8,277,985
Trans, Comm, Pub Util	2,745,656	3,295,999	4,258,891	2,731,078	13,031,624
Wholesale	520,743	1,102,893	1,089,575	2,216,657	4,929,868
Retail	9,100,657	19,675,345	27,894,066	9,943,317	66,613,385
Finance, Ins, Real Estate	1,102,999	1,961,475	2,051,313	2,646,340	7,762,127
Services	3,866,022	12,737,048	23,089,634	6,227,281	45,919,985
Government	0	0	0	0	0
Total	26,468,833	58,467,271	70,152,815	34,191,394	189,280,313
2006					
				Year to Date	
Ag, Forestry, Fish	146,118	336,826			482,944
Mining	28	96			124
Construction	1,926,355	7,701,990			9,628,345
Manufacturing	662,842	1,965,980			2,628,822
Trans, Comm, Pub Util	2,139,209	3,567,681			5,706,890
Wholesale	429,862	1,034,842			1,464,704
Retail	10,754,666	20,929,871			31,684,537
Finance, Ins, Real Estate	1,654,779	1,087,987			2,742,766
Services	3,926,670	12,960,158			16,886,828
Government	0	0			0
Total	21,640,529	49,585,431			71,225,960

Table 5.7

Seward Sales

Seward TAXABLE Sales by Industry by Quarter - 2003-2006 - in \$					
	1st Quarter	2nd Quarter	3rd Quarter	4th Quarter	Total
2003					
Ag, Forestry, Fish	11,673	70,505	116,949	18,196	217,323
Mining	0	1,754	1,701	0	3,455
Construction	126,874	190,057	174,588	192,071	683,590
Manufacturing	144,853	157,138	183,847	143,810	629,648
Trans, Comm, Pub Util	588,465	806,530	941,349	585,325	2,921,669
Wholesale	15,297	40,058	49,420	14,245	119,020
Retail	5,600,762	11,465,828	16,898,663	6,306,836	40,272,089
Finance, Ins, Real Estate	330,069	415,752	530,822	316,440	1,593,083
Services	2,466,511	8,924,459	15,805,507	2,712,379	29,908,856
Government	0	0	0	0	0
Total	9,284,504	22,072,081	34,702,846	10,289,302	76,348,733
2004					
Ag, Forestry, Fish	11,923	77,870	129,744	7,800	227,337
Mining	0	0	0	0	0
Construction	167,430	198,782	187,781	185,187	739,180
Manufacturing	131,626	162,634	163,756	147,012	605,028
Trans, Comm, Pub Util	581,778	758,614	1,009,472	503,592	2,853,456
Wholesale	23,473	34,969	34,753	14,723	107,918
Retail	5,834,809	11,956,679	18,197,996	6,454,323	42,443,807
Finance, Ins, Real Estate	295,698	394,778	563,136	329,459	1,583,071
Services	2,448,027	9,407,577	16,787,230	2,744,330	31,387,164
Government	0	0	0	0	0
Total	9,494,764	22,991,903	37,073,868	10,386,426	79,946,961
2005					
Ag, Forestry, Fish	8,489	87,792	143,691	14,674	254,646
Mining	0	0	0	0	0
Construction	160,163	215,539	169,742	161,680	707,124
Manufacturing	87,178	135,184	142,892	131,956	497,210
Trans, Comm, Pub Util	588,048	789,089	995,735	736,225	3,109,097
Wholesale	14,534	34,511	43,463	14,577	107,085
Retail	6,380,951	13,617,744	20,810,966	7,067,305	47,876,966
Finance, Ins, Real Estate	284,939	470,933	630,457	375,315	1,761,644
Services	2,566,683	10,016,817	18,184,683	2,921,804	33,689,987
Government	0	0	0	0	0
Total	10,090,985	25,367,609	41,121,629	11,423,536	88,003,759
2006					
				Year to Date	
Ag, Forestry, Fish	11,665	65,204			76,869
Mining	28	96			124
Construction	159,287	191,709			350,996
Manufacturing	93,239	178,635			271,874
Trans, Comm, Pub Util	578,840	750,338			1,329,178
Wholesale	10,932	36,432			47,364
Retail	6,538,160	14,202,308			20,740,468
Finance, Ins, Real Estate	307,643	450,786			758,429
Services	2,462,170	10,485,986			12,948,156
Government	0	0			0
Total	10,161,964	26,361,494			36,523,458

Table 5.8

Seward Construction

Seward 2nd Quarter Permit VALUES by Type - 2001-2006 - in \$

	2001	2002	2003	2004	2005	2006	Annual Change
Residential - New	0	400,000	215,000	873,000	388,000	415,000	7.0%
Residential - Add/Alter	73,000	169,157	100,000	144,900	84,220	65,200	-22.6%
Commercial - New	155,000	3,294,730	3,313,000	5,000,000	271,320	800,000	194.9%
Commercial - Add/Alter	438,239	25,000	44,010	1,426,000	15,000	904,472	5929.8%
TOTAL	666,239	3,888,887	3,672,010	7,443,900	758,540	2,184,672	188.0%
Annual Change		483.7%	-5.6%	102.7%	-89.8%	188.0%	

Table 5.9

Seward 2nd Quarter Permit VALUES by Type - 1988-2006

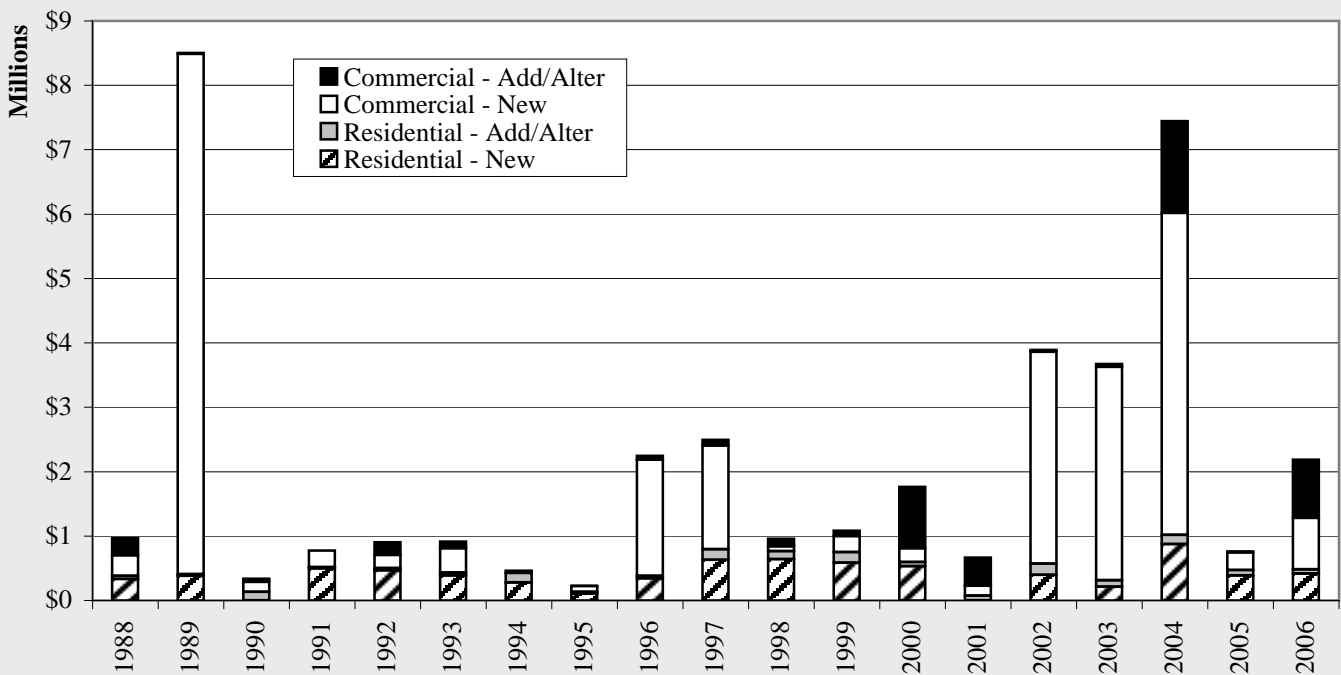

Chart 5.13

**Seward 2nd Quarter Permit VALUES
Percent by Type - 2006**

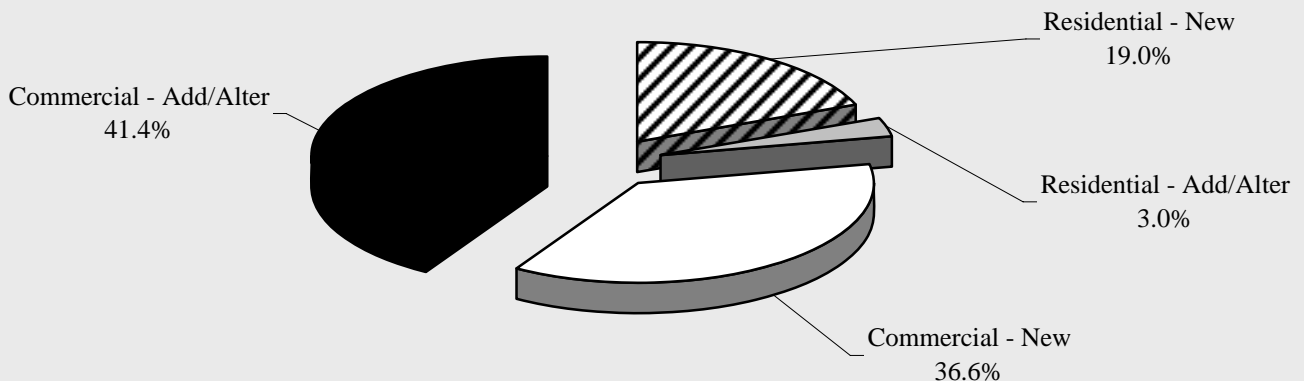

Chart 5.14

Seward Construction

Seward 2nd Quarter Permit VOLUME by Type - 2001-2006							
	2001	2002	2003	2004	2005	2006	Annual Change
Residential - New	0	1	2	4	3	3	0.0%
Residential - Add/Alter	3	15	3	7	9	7	-22.2%
Commercial - New	3	4	4	1	5	11	120.0%
Commercial - Add/Alter	8	9	4	9	2	2	0.0%
TOTAL	14	29	13	21	19	23	21.1%
Annual Change		107.1%	-55.2%	61.5%	-9.5%	21.1%	

Table 5.10

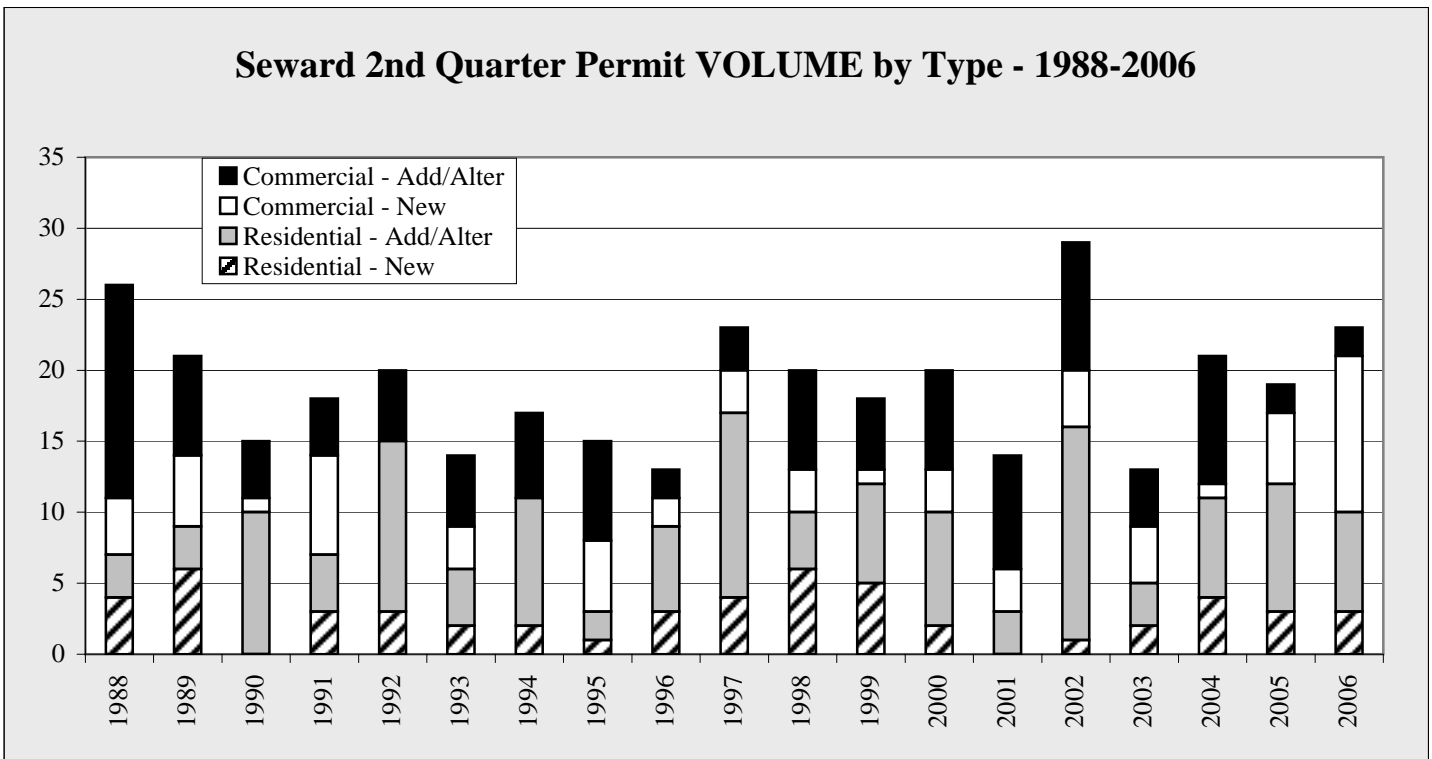

Chart 5.15

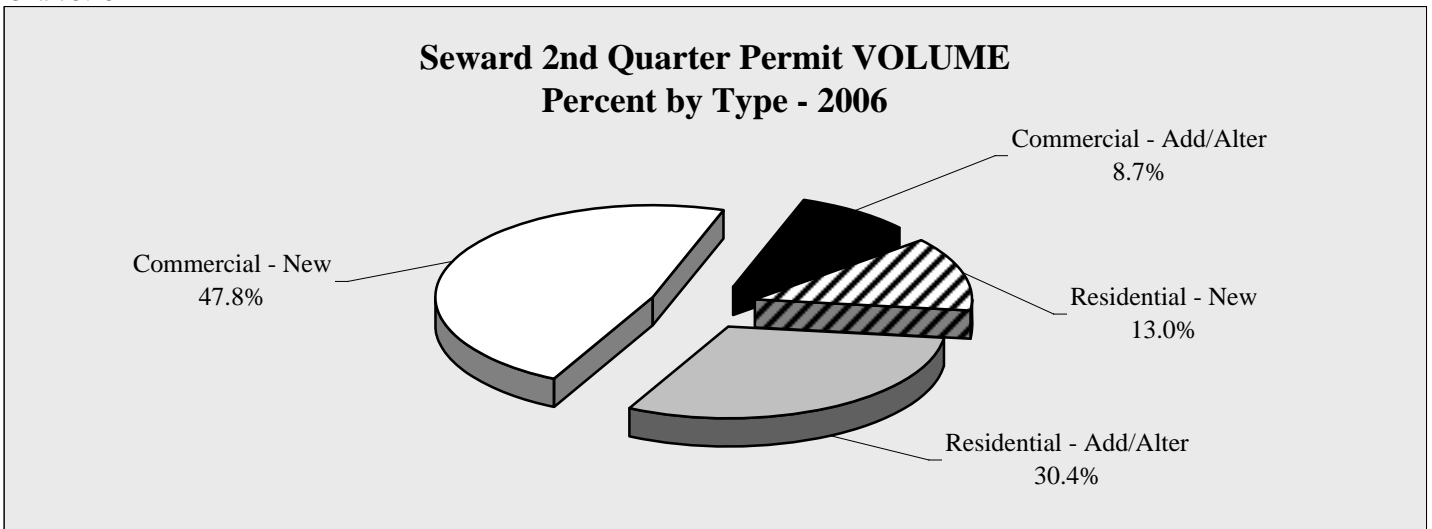

Chart 5.16

Seward Construction

Seward YTD 6/30 Permit VALUES by Type - 2001-2006 - in \$							
	2001	2002	2003	2004	2005	2006	Annual Change
Residential - New	0	520,000	333,000	873,000	1,311,000	415,000	-68.3%
Residential - Add/Alter	103,200	194,653	157,500	192,900	87,520	66,200	-24.4%
Commercial - New	155,000	3,294,730	3,385,000	12,500,000	277,320	800,000	188.5%
Commercial - Add/Alter	824,739	360,944	1,701,865	1,619,600	255,000	1,525,689	498.3%
TOTAL	1,082,939	4,370,327	5,577,365	15,185,500	1,930,840	2,806,889	45.4%
Annual Change		303.6%	27.6%	172.3%	-87.3%	45.4%	

Table 5.11

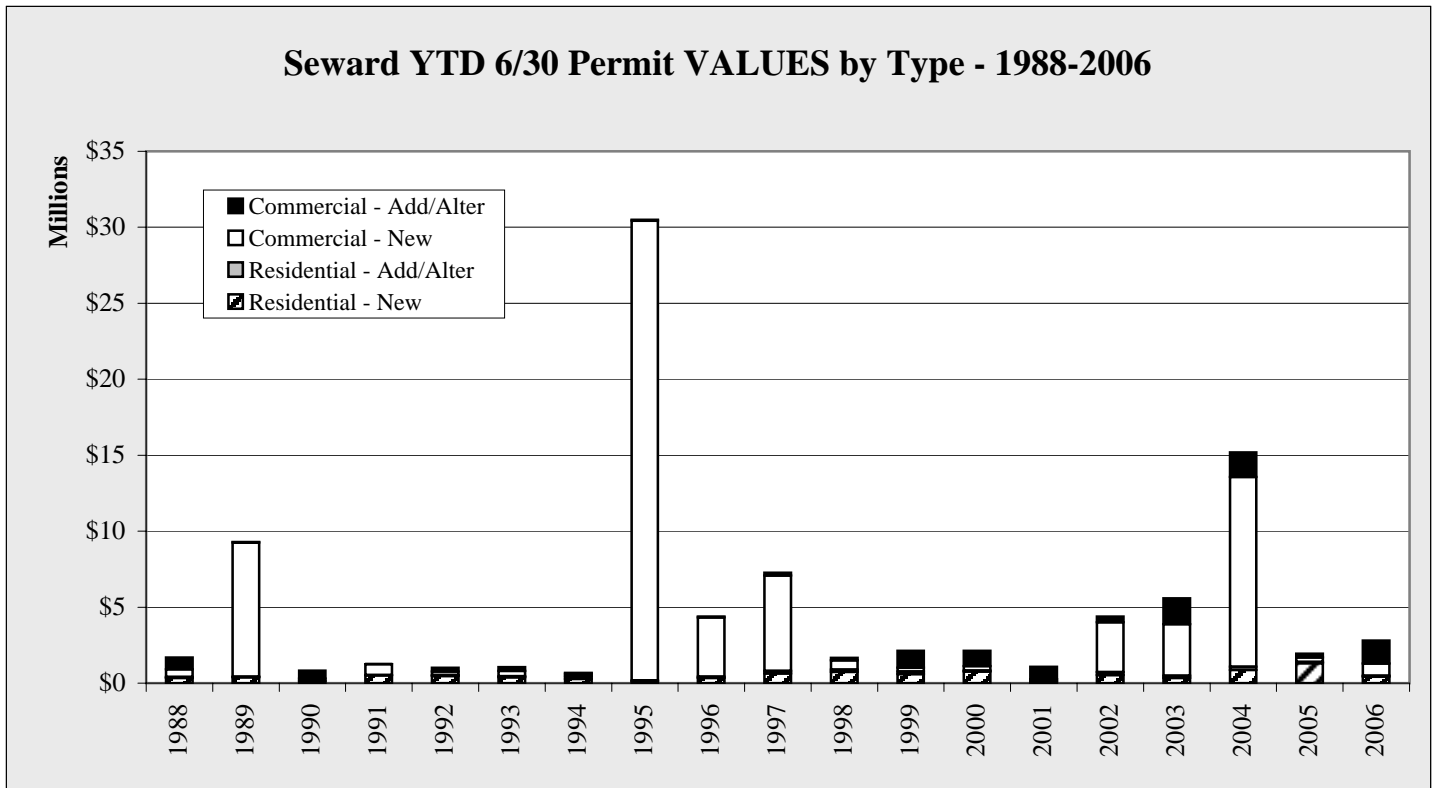

Chart 5.17

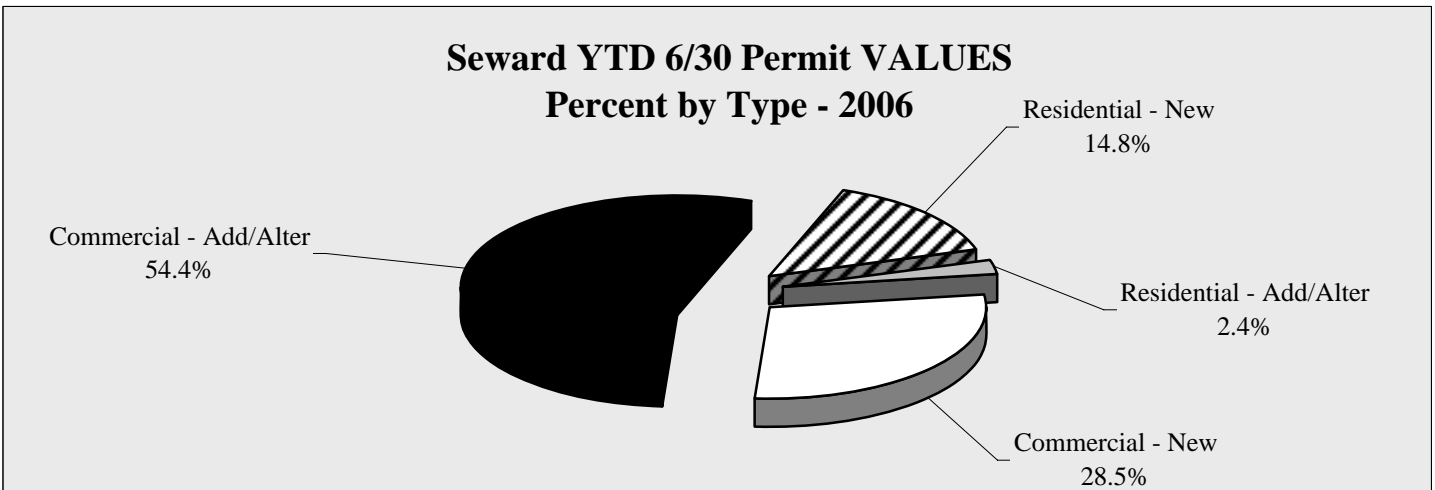

Chart 5.18

Seward Construction

Seward YTD 6/30 Permit VOLUME by Type - 2001-2006							
	2001	2002	2003	2004	2005	2006	Annual Change
Residential - New	0	2	3	4	7	3	-57.1%
Residential - Add/Alter	7	18	5	9	11	8	-27.3%
Commercial - New	3	4	5	2	7	11	57.1%
Commercial - Add/Alter	15	15	11	13	6	8	33.3%
TOTAL	25	39	24	28	31	30	-3.2%
Annual Change		56.0%	-38.5%	16.7%	10.7%	-3.2%	

Table 5.12

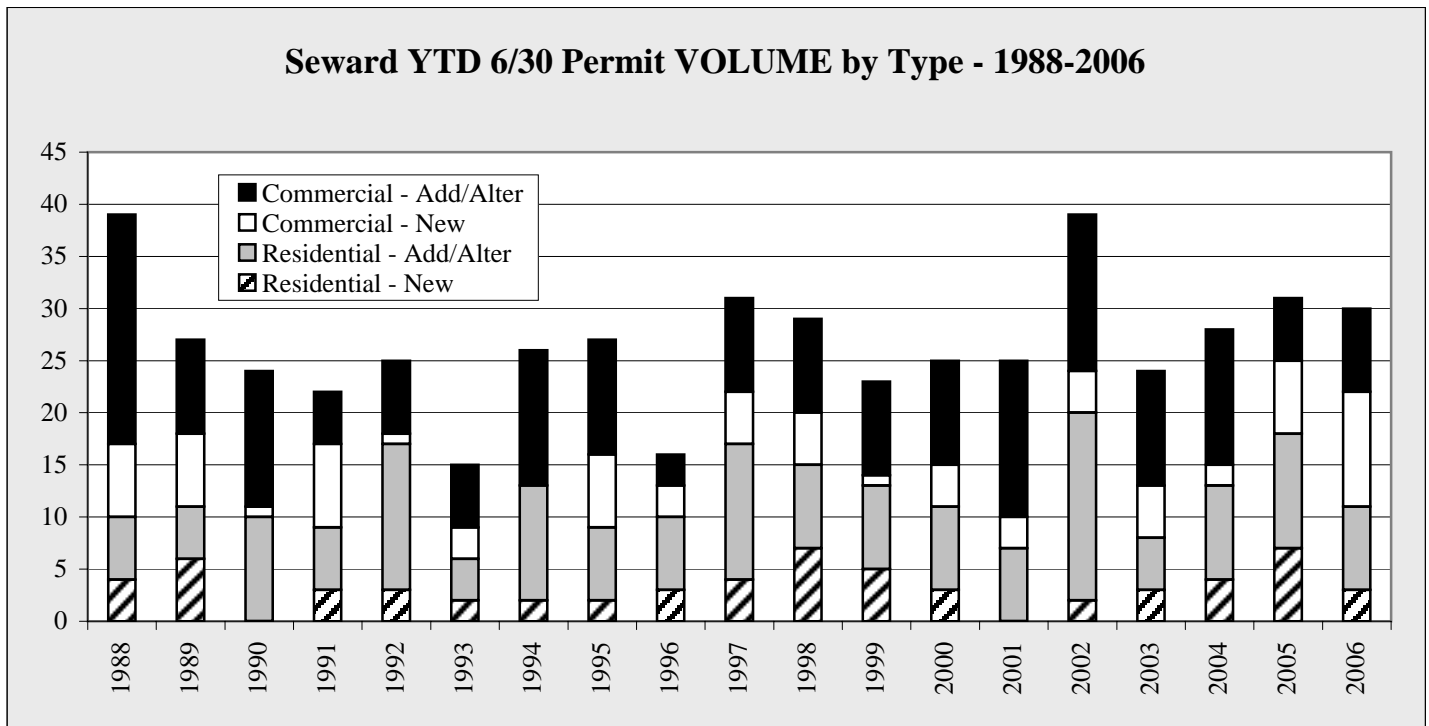

Chart 5.19

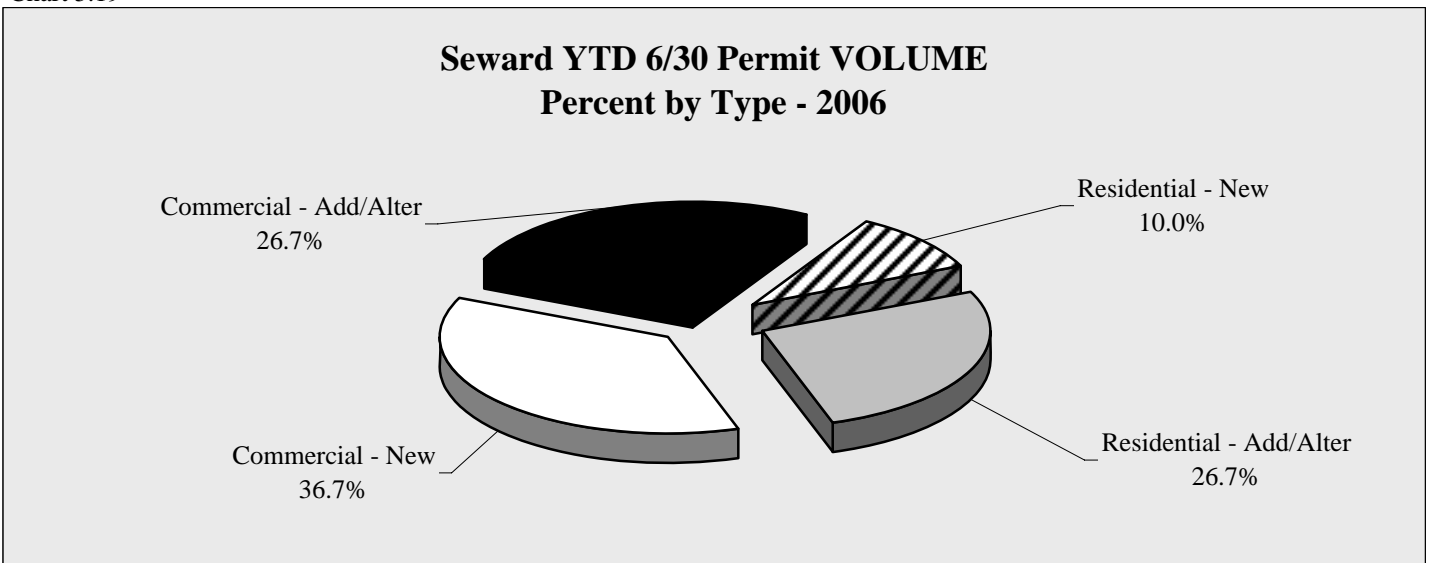

Chart 5.20

Seward Construction

Seward Annual Permit VALUES by Type by Quarter - 2000-2006 - in \$					
	1st Quarter	2nd Quarter	3rd Quarter	4th Quarter	Total
2000					
Residential - New	230,000	530,000	263,000	0	1,023,000
Residential - Add/Alter	0	67,600	39,000	339,400	446,000
Commercial - New	85,000	210,000	330,000	200,000	825,000
Commercial - Add/Alter	40,300	957,800	79,465	80,000	1,157,565
TOTAL	355,300	1,765,400	711,465	619,400	3,451,565
2001					
Residential - New	0	0	150,000	300,000	450,000
Residential - Add/Alter	30,200	73,000	136,014	105,000	344,214
Commercial - New	0	155,000	331,028	0	486,028
Commercial - Add/Alter	386,500	438,239	25,000	587,000	1,436,739
TOTAL	416,700	666,239	642,042	992,000	2,716,981
2002					
Residential - New	120,000	400,000	205,000	0	725,000
Residential - Add/Alter	25,496	169,157	27,555	19,800	242,008
Commercial - New	0	3,294,730	750,000	2,100,000	6,144,730
Commercial - Add/Alter	335,944	25,000	325,021	113,000	798,965
TOTAL	481,440	3,888,887	1,307,576	2,232,800	7,910,703
2003					
Residential - New	118,000	215,000	744,500	0	1,077,500
Residential - Add/Alter	57,500	100,000	87,000	50,000	294,500
Commercial - New	72,000	3,313,000	900,000	5,000	4,290,000
Commercial - Add/Alter	1,657,855	44,010	101,400	517,500	2,320,765
TOTAL	1,905,355	3,672,010	1,832,900	572,500	7,982,765
2004					
Residential - New	0	873,000	1,257,000	0	2,130,000
Residential - Add/Alter	48,000	144,900	299,500	8,000	500,400
Commercial - New	7,500,000	5,000,000	518,800	0	13,018,800
Commercial - Add/Alter	193,600	1,426,000	191,000	251,350	2,061,950
TOTAL	7,741,600	7,443,900	2,266,300	259,350	17,711,150
2005					
Residential - New	923,000	388,000	455,000	1,500	1,767,500
Residential - Add/Alter	3,300	84,220	6,761	40,457	134,738
Commercial - New	6,000	271,320	88,400	60,000	425,720
Commercial - Add/Alter	240,000	15,000	275,285	4,900	535,185
TOTAL	1,172,300	758,540	825,446	106,857	2,863,143
2006					
					Year to Date
Residential - New	0	415,000			415,000
Residential - Add/Alter	1,000	65,200			66,200
Commercial - New	0	800,000			800,000
Commercial - Add/Alter	621,217	904,472			1,525,689
TOTAL	622,217	2,184,672			2,806,889

Table 5.13

Seward Construction

Seward Annual Permit VOLUME by Type by Quarter - 2000-2006					
	1st Quarter	2nd Quarter	3rd Quarter	4th Quarter	Total
2000					
Residential - New	1	2	2	0	5
Residential - Add/Alter	0	8	7	4	19
Commercial - New	1	3	3	1	8
Commercial - Add/Alter	3	7	5	4	19
TOTAL	5	20	17	9	51
2001					
Residential - New	0	0	1	2	3
Residential Add/Alter	4	3	9	2	18
Commercial - New	0	3	3	0	6
Commercial - Add/Alter	7	8	1	5	21
TOTAL	11	14	14	9	48
2002					
Residential - New	1	1	2	0	4
Residential Add/Alter	3	15	3	4	25
Commercial - New	0	4	1	3	8
Commercial - Add/Alter	6	9	8	4	27
TOTAL	10	29	14	11	64
2003					
Residential - New	1	2	5	0	8
Residential Add/Alter	2	3	5	1	11
Commercial - New	1	4	1	1	7
Commercial - Add/Alter	7	4	4	9	24
TOTAL	11	13	15	11	50
2004					
Residential - New	0	4	8	0	12
Residential Add/Alter	2	7	5	1	15
Commercial - New	1	1	2	0	4
Commercial - Add/Alter	4	9	4	6	23
TOTAL	7	21	19	7	54
2005					
Residential - New	4	3	3	1	11
Residential Add/Alter	2	9	5	3	19
Commercial - New	2	5	2	1	10
Commercial - Add/Alter	4	2	6	2	14
TOTAL	12	19	16	7	54
2006					
				Year to Date	
Residential - New	0	3			3
Residential Add/Alter	1	7			8
Commercial - New	0	11			11
Commercial - Add/Alter	6	2			8
TOTAL	7	23			30

Table 5.14

Soldotna Sales

Soldotna 2nd Quarter GROSS Sales by Industry - 2001-2006 - in \$							
	2001	2002	2003	2004	2005	2006	Annual Change
Ag, Forestry, Fish	486,756	493,143	558,058	645,572	1,029,914	1,594,497	54.8%
Mining	77,886	106,949	122,012	154,892	185,929	19,715	-89.4%
Construction	4,464,446	4,927,290	3,954,148	5,879,390	5,043,482	10,941,136	116.9%
Manufacturing	1,611,027	1,727,614	2,288,148	1,132,457	1,382,354	1,404,091	1.6%
Trans, Comm, Pub Util	4,573,146	3,531,451	3,827,252	4,717,552	5,435,867	5,837,854	7.4%
Wholesale	6,981,240	7,353,520	9,554,591	8,967,548	3,051,398	3,105,439	1.8%
Retail	45,690,237	49,057,454	52,177,533	54,022,404	57,456,232	58,850,620	2.4%
Finance, Ins, Real Estate	2,223,114	2,994,570	2,559,936	2,957,541	3,066,766	3,491,418	13.8%
Services	8,929,421	9,562,822	10,177,886	10,824,252	11,003,326	12,375,121	12.5%
Government	5,238	7,859	8,680	8,521	8,502	13,251	55.9%
Total	75,042,511	79,762,672	85,228,244	89,310,129	87,663,770	97,633,142	11.4%
Annual Change		6.3%	6.9%	4.8%	-1.8%	11.4%	

Table 6.1

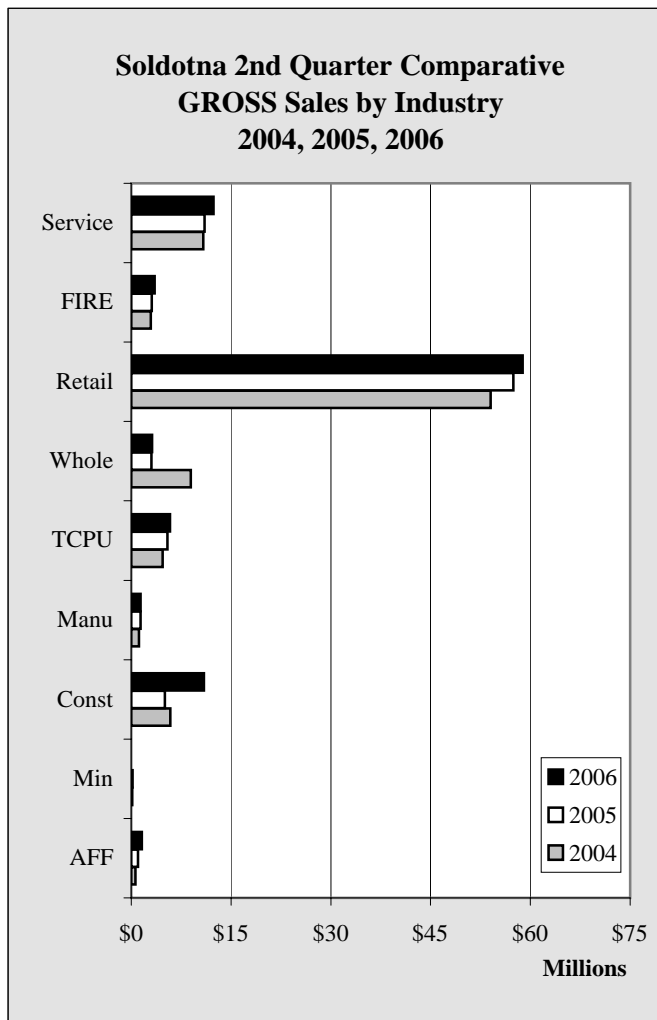

Chart 6.1

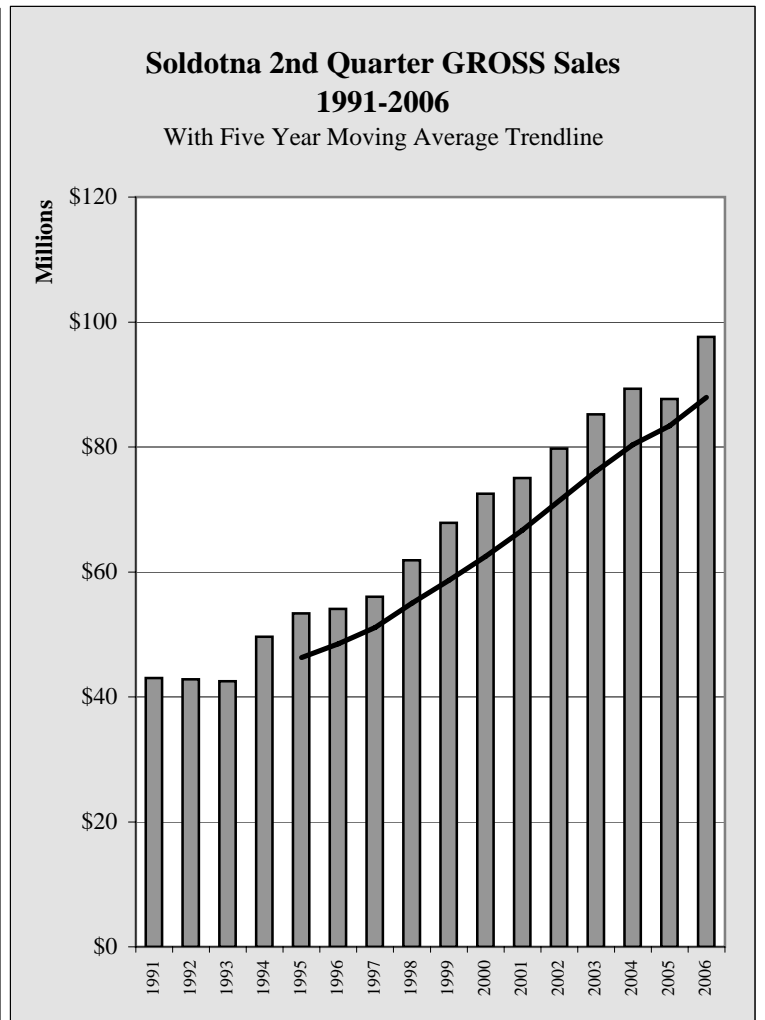

Chart 6.2

Soldotna Sales

Soldotna 2nd Quarter TAXABLE Sales by Industry - 2001-2006 - in \$							
	2001	2002	2003	2004	2005	2006	Annual Change
Ag, Forestry, Fish	314,053	286,565	297,426	270,912	265,254	313,460	18.2%
Mining	10,242	7,414	7,401	5,828	6,989	1,587	-77.3%
Construction	301,807	329,128	430,437	377,000	394,690	308,279	-21.9%
Manufacturing	465,257	429,327	436,364	375,725	408,360	385,863	-5.5%
Trans, Comm, Pub Util	2,584,818	2,619,156	2,964,183	2,986,649	3,247,424	3,284,609	1.1%
Wholesale	282,881	231,064	288,627	254,535	262,964	263,156	0.1%
Retail	33,538,956	33,719,840	36,964,223	38,706,949	41,791,331	44,029,453	5.4%
Finance, Ins, Real Estate	1,222,567	1,270,517	1,163,695	1,131,365	1,088,803	1,107,265	1.7%
Services	4,188,255	4,604,088	4,465,631	4,894,259	4,697,508	5,453,487	16.1%
Government	5,238	7,859	8,680	8,521	8,502	13,251	55.9%
Total	42,914,074	43,504,958	47,026,667	49,011,743	52,171,825	55,160,410	5.7%
Annual Change		1.4%	8.1%	4.2%	6.4%	5.7%	

Table 6.2

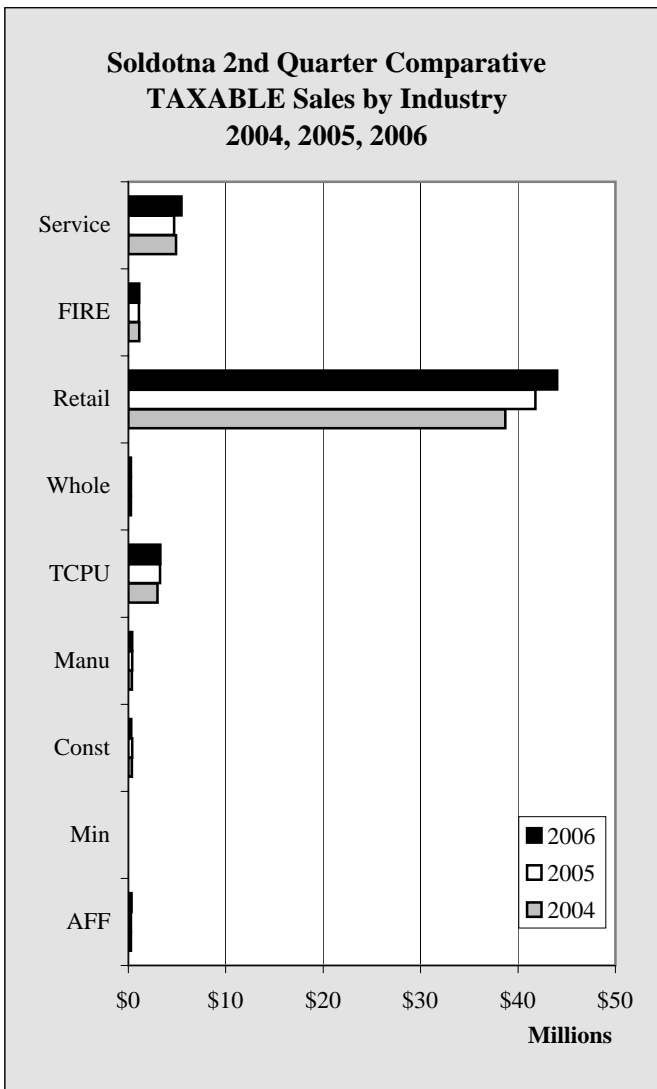

Chart 6.3

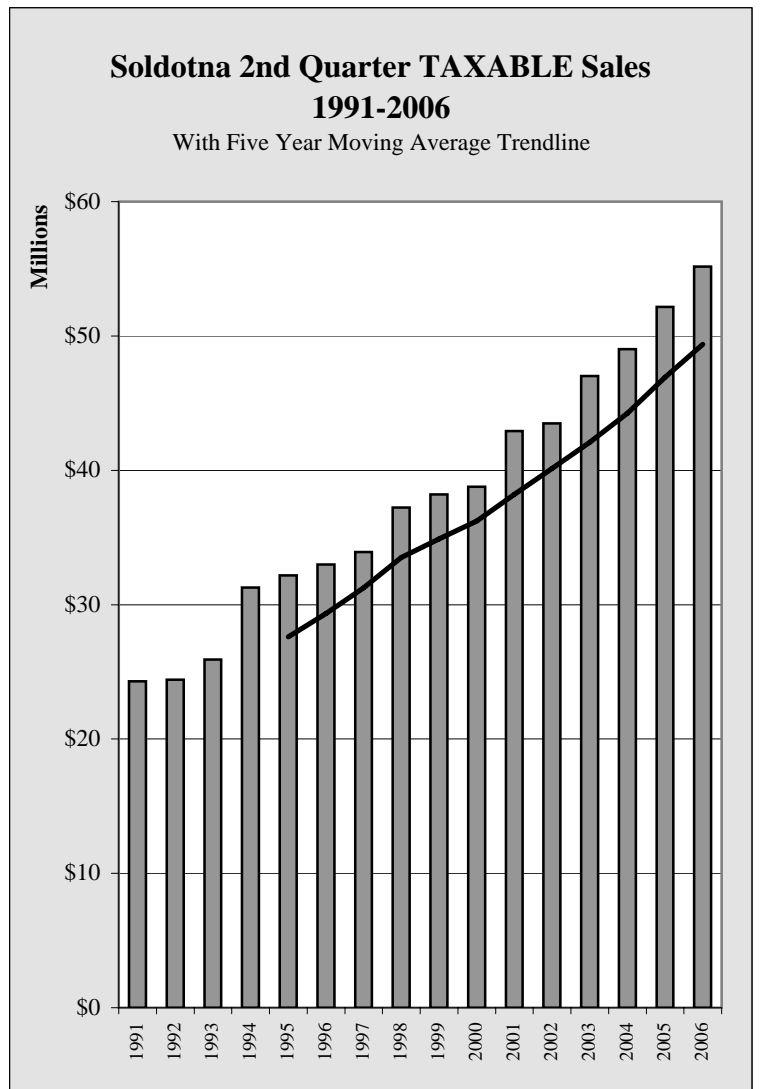

Chart 6.4

Soldotna Sales

Soldotna YTD 6/30 GROSS Sales by Industry - 2001-2006 - in \$							
	2001	2002	2003	2004	2005	2006	Annual Change
Ag, Forestry, Fish	701,976	724,497	845,479	1,202,557	1,608,367	2,425,775	50.8%
Mining	127,358	205,050	232,641	247,073	275,968	62,038	-77.5%
Construction	8,479,817	8,150,584	7,952,066	8,835,663	9,677,559	17,057,586	76.3%
Manufacturing	2,578,965	2,628,508	3,417,539	1,676,240	1,896,102	2,054,060	8.3%
Trans, Comm, Pub Util	9,337,601	7,217,176	8,038,579	9,516,022	10,833,849	12,020,901	11.0%
Wholesale	13,808,302	15,425,570	16,863,880	18,687,699	5,142,121	5,006,964	-2.6%
Retail	80,405,486	85,544,701	88,958,446	93,629,319	98,363,899	102,394,149	4.1%
Finance, Ins, Real Estate	4,389,995	5,257,521	5,028,022	5,991,032	5,868,065	6,323,141	7.8%
Services	16,003,543	16,926,256	18,128,574	19,438,767	19,963,083	22,726,086	13.8%
Government	11,745	14,559	20,999	15,425	10,399	24,499	135.6%
Total	135,844,788	142,094,422	149,486,225	159,239,797	153,639,412	170,095,199	10.7%
Annual Change		4.6%	5.2%	6.5%	-3.5%	10.7%	

Table 6.3

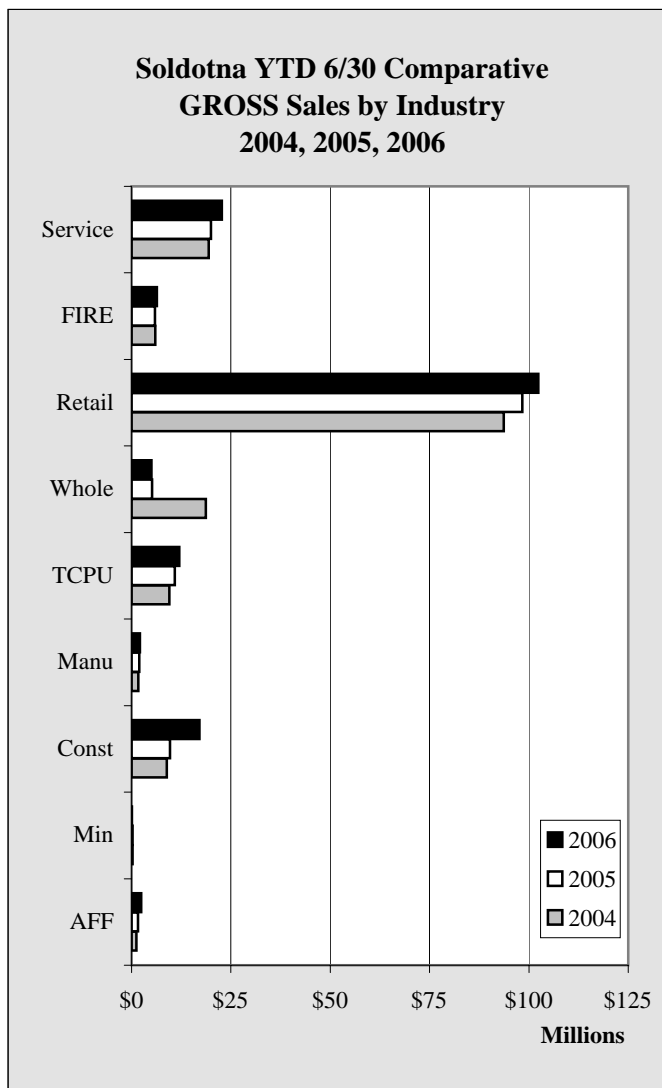

Chart 6.5

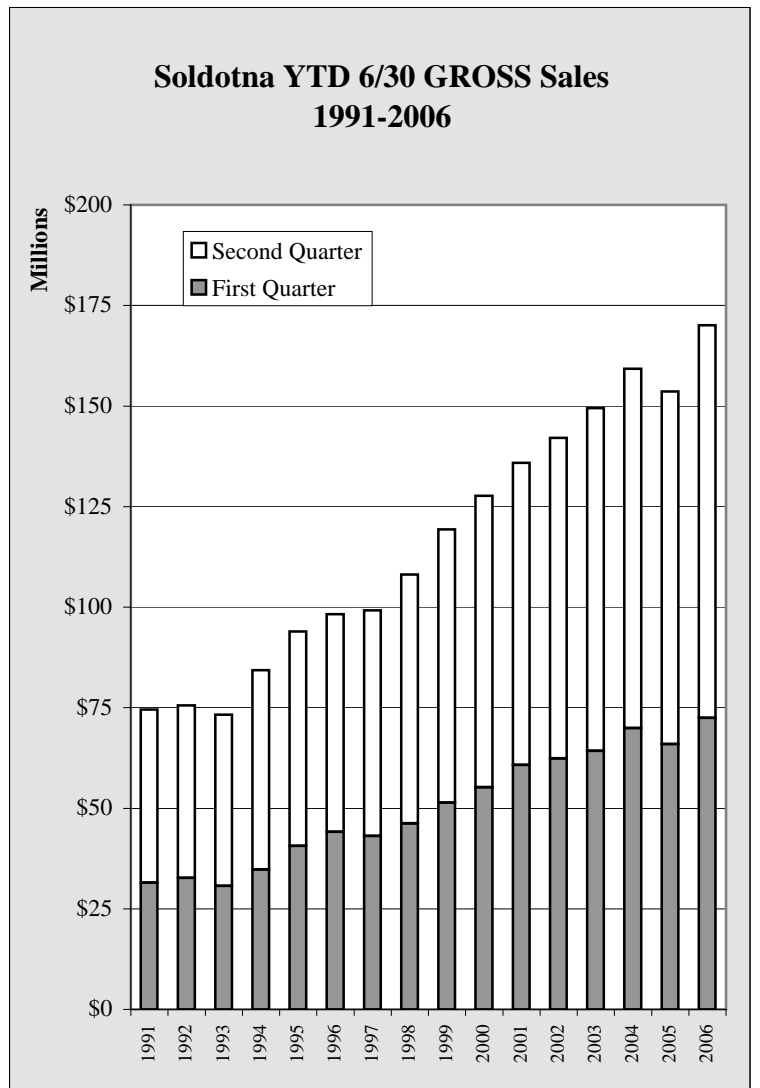

Chart 6.6

Soldotna Sales

Soldotna YTD 6/30 TAXABLE Sales by Industry - 2001-2006 - in \$							
	2001	2002	2003	2004	2005	2006	Annual Change
Ag, Forestry, Fish	497,909	471,817	465,019	490,143	445,949	530,593	19.0%
Mining	17,854	13,861	16,775	12,503	13,134	8,404	-36.0%
Construction	536,325	609,597	732,197	693,390	726,259	607,643	-16.3%
Manufacturing	665,223	610,813	656,069	573,566	598,134	587,859	-1.7%
Trans, Comm, Pub Util	5,169,011	5,371,429	6,183,218	6,326,361	6,551,033	7,076,825	8.0%
Wholesale	407,518	366,501	461,680	408,588	381,830	396,247	3.8%
Retail	58,569,101	59,290,366	62,726,809	67,246,576	71,872,187	76,530,334	6.5%
Finance, Ins, Real Estate	2,294,601	2,443,780	2,311,902	2,093,027	2,052,995	2,158,003	5.1%
Services	7,237,164	8,048,843	7,916,621	8,537,506	8,254,074	9,406,081	14.0%
Government	11,745	14,559	20,999	15,425	10,399	24,499	135.6%
Total	75,406,451	77,241,566	81,491,289	86,397,085	90,905,994	97,326,488	7.1%
Annual Change		2.4%	5.5%	6.0%	5.2%	7.1%	

Table 6.4

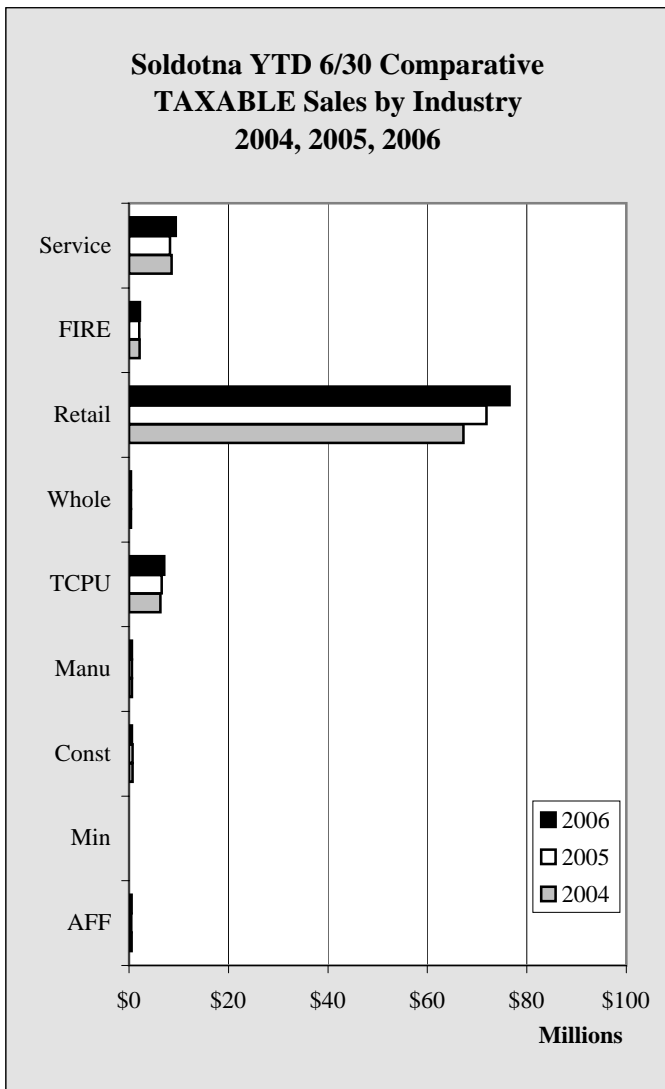

Chart 6.7

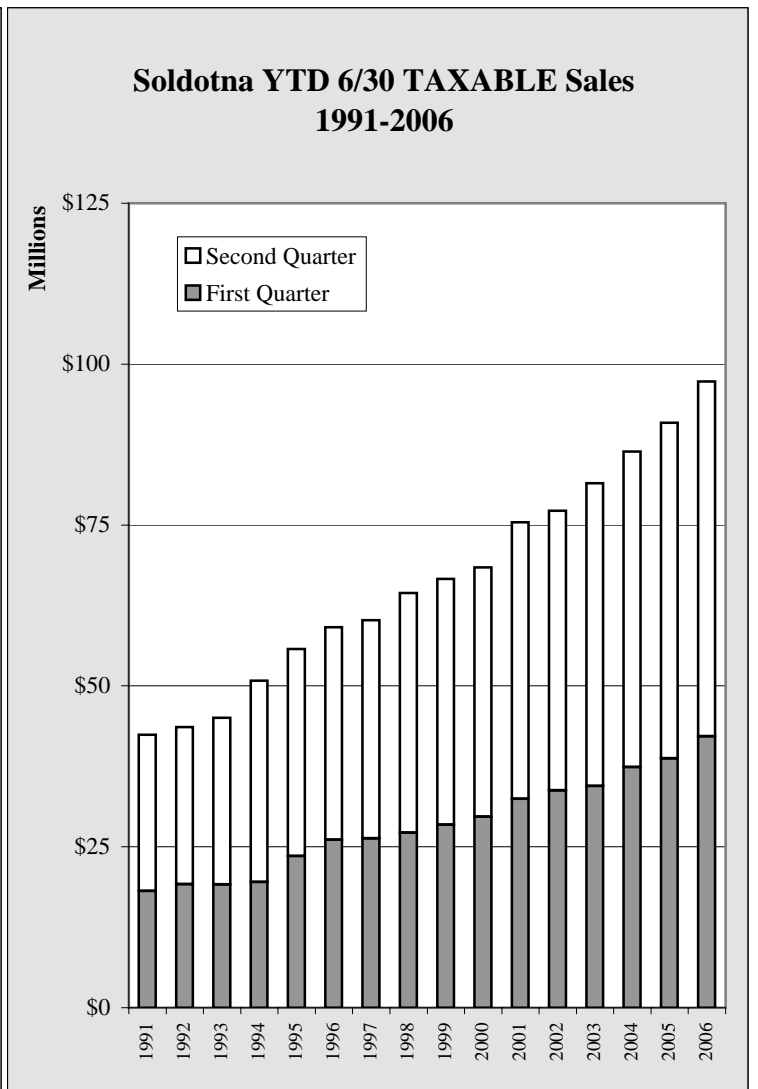

Chart 6.8

Soldotna Sales

Soldotna Annual GROSS Sales by Industry - 2000-2005 - in \$							
	2000	2001	2002	2003	2004	2005	Annual Change
Ag, Forestry, Fish	1,727,448	1,664,917	1,853,591	2,523,473	3,223,216	4,078,212	26.5%
Mining	305,525	305,091	410,684	450,504	548,472	546,212	-0.4%
Construction	20,761,485	19,395,458	22,453,598	20,811,207	27,763,211	50,436,198	81.7%
Manufacturing	5,446,988	5,938,040	6,301,658	7,729,281	4,338,040	5,183,896	19.5%
Trans, Comm, Pub Util	15,708,998	17,799,215	15,900,605	16,342,600	20,227,511	22,177,958	9.6%
Wholesale	32,610,279	31,467,653	40,201,769	34,368,869	28,770,110	15,411,727	-46.4%
Retail	170,201,586	187,606,859	191,924,777	204,697,590	217,639,600	225,491,805	3.6%
Finance, Ins, Real Estate	10,210,170	10,232,574	10,498,855	10,779,337	11,901,005	12,088,564	1.6%
Services	32,265,770	34,689,321	36,332,504	40,165,079	46,824,115	48,527,671	3.6%
Government	17,062	19,103	22,579	41,717	20,979	25,385	21.0%
Total	289,255,311	309,118,231	325,900,620	337,909,657	361,256,259	383,967,628	6.3%
Annual Change		6.9%	5.4%	3.7%	6.9%	6.3%	

Table 6.5

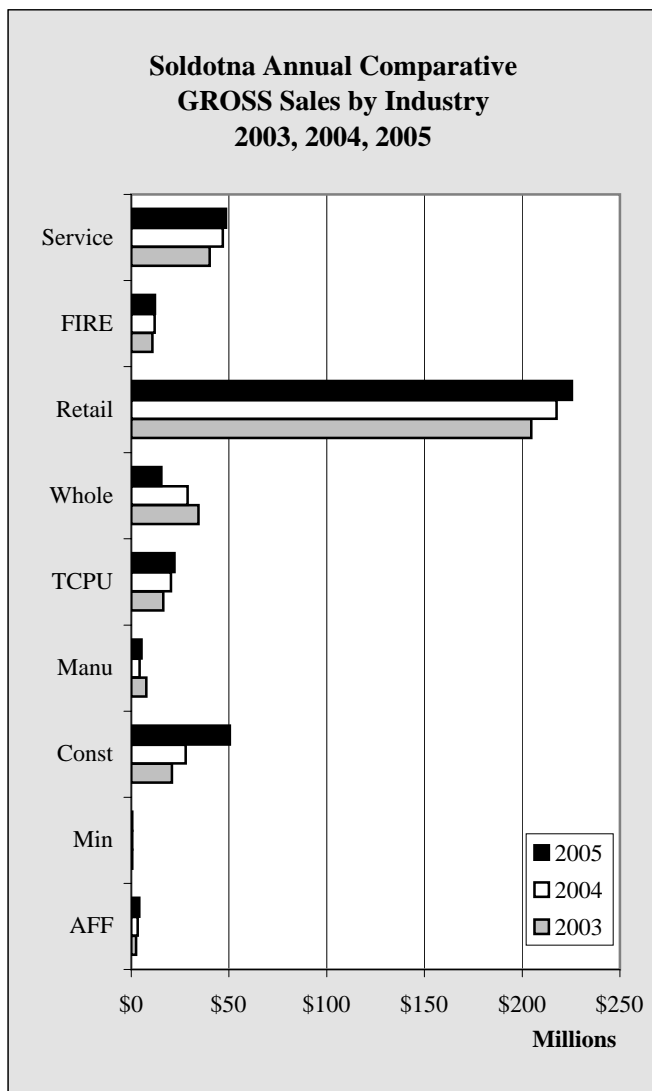

Chart 6.9

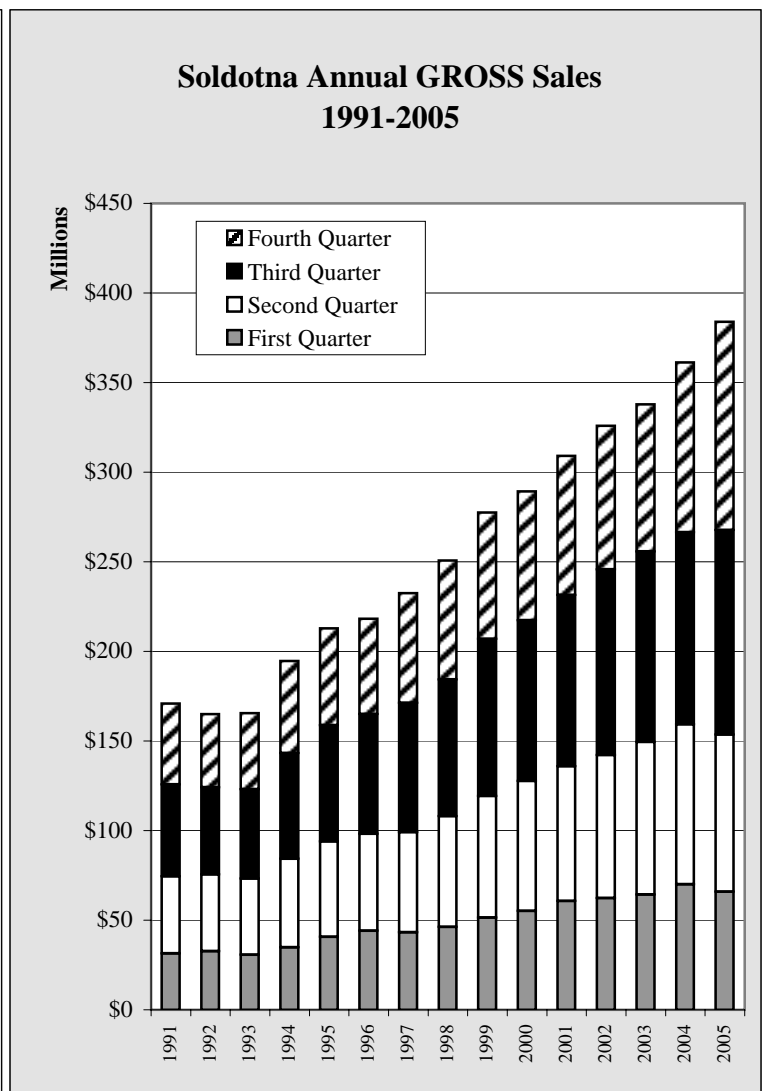

Chart 6.10

Soldotna Sales

Soldotna Annual TAXABLE Sales by Industry - 2000-2005 - in \$							
	2000	2001	2002	2003	2004	2005	Annual Change
Ag, Forestry, Fish	921,908	1,117,793	1,043,812	1,176,634	1,123,088	1,158,422	3.1%
Mining	11,333	35,080	33,278	33,067	20,326	26,132	28.6%
Construction	1,233,755	1,173,265	1,313,633	1,588,752	1,413,366	1,494,051	5.7%
Manufacturing	1,567,147	1,638,254	1,635,572	1,674,325	1,663,082	1,678,178	0.9%
Trans, Comm, Pub Util	10,311,502	10,527,433	11,178,060	12,295,182	12,426,832	13,226,664	6.4%
Wholesale	715,161	786,443	763,236	997,320	805,376	794,066	-1.4%
Retail	124,618,575	136,194,643	138,159,104	151,124,891	159,832,138	170,370,417	6.6%
Finance, Ins, Real Estate	4,545,775	5,207,613	5,302,811	4,480,551	4,387,368	4,299,626	-2.0%
Services	15,493,910	15,718,811	17,527,307	17,216,461	18,364,373	18,260,949	-0.6%
Government	17,062	19,103	22,579	41,717	20,979	25,385	21.0%
Total	159,436,128	172,418,438	176,979,392	190,628,900	200,056,928	211,333,890	5.6%
Annual Change		8.1%	2.6%	7.7%	4.9%	5.6%	

Table 6.6

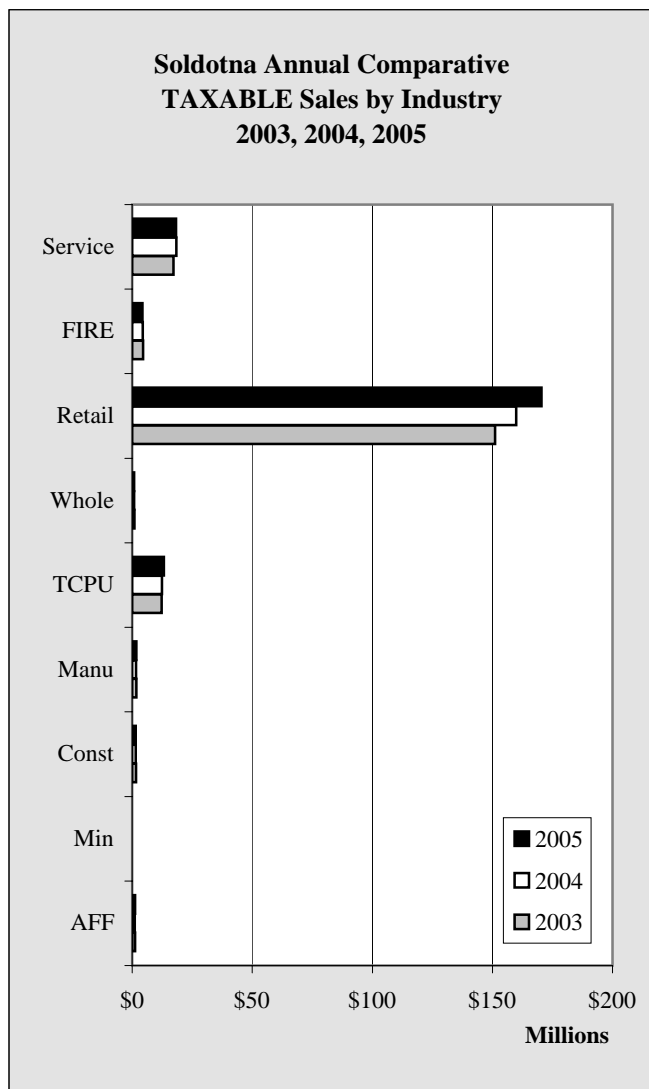

Chart 6.11

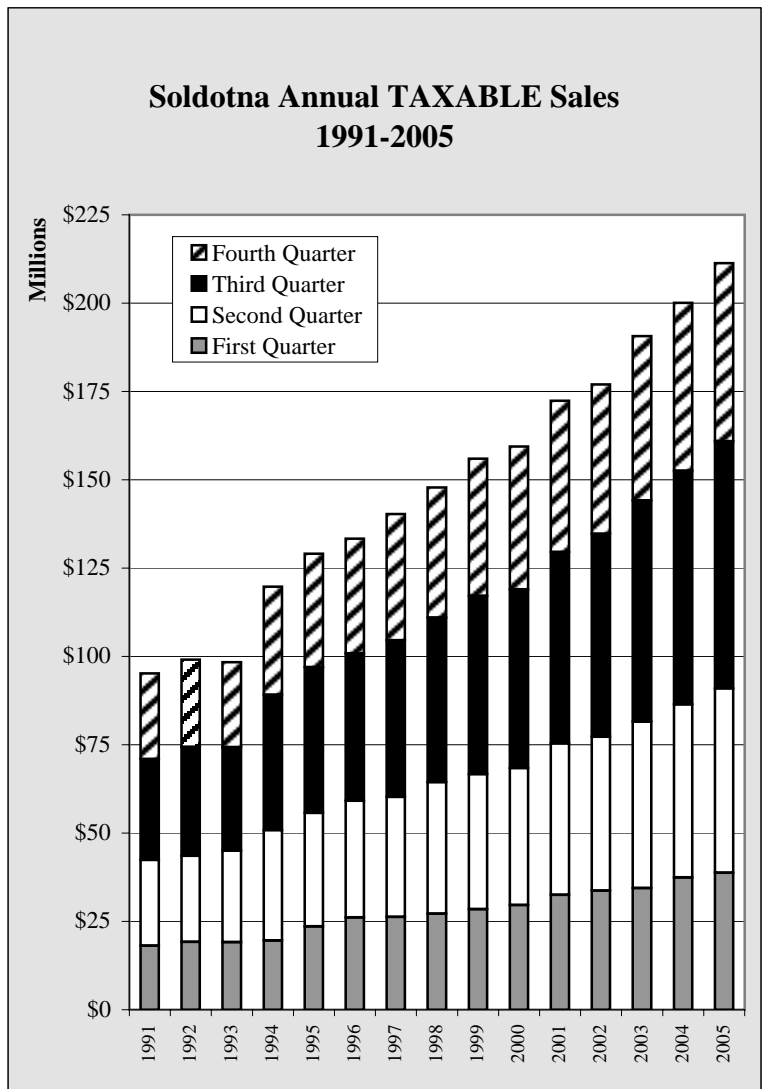

Chart 6.12

Soldotna Sales

Soldotna GROSS Sales by Industry by Quarter - 2003-2006 - in \$					
	1st Quarter	2nd Quarter	3rd Quarter	4th Quarter	Total
2003					
Ag, Forestry, Fish	287,421	558,058	920,446	757,548	2,523,473
Mining	110,629	122,012	99,139	118,724	450,504
Construction	3,997,918	3,954,148	6,733,409	6,125,732	20,811,207
Manufacturing	1,129,391	2,288,148	2,843,498	1,468,244	7,729,281
Trans, Comm, Pub Util	4,211,327	3,827,252	3,716,921	4,587,100	16,342,600
Wholesale	7,309,289	9,554,591	10,562,562	6,942,427	34,368,869
Retail	36,780,913	52,177,533	65,995,934	49,743,210	204,697,590
Finance, Ins, Real Estate	2,468,086	2,559,936	2,839,072	2,912,243	10,779,337
Services	7,950,688	10,177,886	12,545,141	9,491,364	40,165,079
Government	12,319	8,680	12,192	8,526	41,717
Total	64,257,981	85,228,244	106,268,314	82,155,118	337,909,657
2004					
Ag, Forestry, Fish	556,985	645,572	1,043,046	977,613	3,223,216
Mining	92,181	154,892	136,149	165,250	548,472
Construction	2,956,273	5,879,390	9,248,884	9,678,664	27,763,211
Manufacturing	543,783	1,132,457	1,857,842	803,958	4,338,040
Trans, Comm, Pub Util	4,798,470	4,717,552	5,692,042	5,019,447	20,227,511
Wholesale	9,720,151	8,967,548	3,326,912	6,755,499	28,770,110
Retail	39,606,915	54,022,404	70,285,913	53,724,368	217,639,600
Finance, Ins, Real Estate	3,033,491	2,957,541	2,839,045	3,070,928	11,901,005
Services	8,614,515	10,824,252	12,762,986	14,622,362	46,824,115
Government	6,904	8,521	2,880	2,674	20,979
Total	69,929,668	89,310,129	107,195,699	94,820,763	361,256,259
2005					
Ag, Forestry, Fish	578,453	1,029,914	1,238,556	1,231,289	4,078,212
Mining	90,039	185,929	229,355	40,889	546,212
Construction	4,634,077	5,043,482	9,807,694	30,950,945	50,436,198
Manufacturing	513,748	1,382,354	2,005,897	1,281,897	5,183,896
Trans, Comm, Pub Util	5,397,982	5,435,867	5,430,966	5,913,143	22,177,958
Wholesale	2,090,723	3,051,398	3,752,479	6,517,127	15,411,727
Retail	40,907,667	57,456,232	74,973,117	52,154,789	225,491,805
Finance, Ins, Real Estate	2,801,299	3,066,766	2,954,412	3,266,087	12,088,564
Services	8,959,757	11,003,326	13,576,633	14,987,955	48,527,671
Government	1,897	8,502	11,907	3,079	25,385
Total	65,975,642	87,663,770	113,981,016	116,347,200	383,967,628
2006					
					Year to Date
Ag, Forestry, Fish	831,278	1,594,497			2,425,775
Mining	42,323	19,715			62,038
Construction	6,116,450	10,941,136			17,057,586
Manufacturing	649,969	1,404,091			2,054,060
Trans, Comm, Pub Util	6,183,047	5,837,854			12,020,901
Wholesale	1,901,525	3,105,439			5,006,964
Retail	43,543,529	58,850,620			102,394,149
Finance, Ins, Real Estate	2,831,723	3,491,418			6,323,141
Services	10,350,965	12,375,121			22,726,086
Government	11,248	13,251			24,499
Total	72,462,057	97,633,142			170,095,199

Table 6.7

Soldotna Sales

Soldotna TAXABLE Sales by Industry by Quarter - 2003-2006 - in \$					
	1st Quarter	2nd Quarter	3rd Quarter	4th Quarter	Total
2003					
Ag, Forestry, Fish	167,593	297,426	457,868	253,747	1,176,634
Mining	9,374	7,401	7,885	8,407	33,067
Construction	301,760	430,437	464,677	391,878	1,588,752
Manufacturing	219,705	436,364	739,665	278,591	1,674,325
Trans, Comm, Pub Util	3,219,035	2,964,183	2,959,644	3,152,320	12,295,182
Wholesale	173,053	288,627	339,309	196,331	997,320
Retail	25,762,586	36,964,223	50,726,050	37,672,032	151,124,891
Finance, Ins, Real Estate	1,148,207	1,163,695	1,176,522	992,127	4,480,551
Services	3,450,990	4,465,631	5,695,459	3,604,381	17,216,461
Government	12,319	8,680	12,192	8,526	41,717
Total	34,464,622	47,026,667	62,579,271	46,558,340	190,628,900
2004					
Ag, Forestry, Fish	219,231	270,912	444,134	188,811	1,123,088
Mining	6,675	5,828	3,030	4,793	20,326
Construction	316,390	377,000	369,202	350,774	1,413,366
Manufacturing	197,841	375,725	804,097	285,419	1,663,082
Trans, Comm, Pub Util	3,339,712	2,986,649	2,949,371	3,151,100	12,426,832
Wholesale	154,053	254,535	263,334	133,454	805,376
Retail	28,539,627	38,706,949	53,991,818	38,593,744	159,832,138
Finance, Ins, Real Estate	961,662	1,131,365	1,279,711	1,014,630	4,387,368
Services	3,643,247	4,894,259	6,072,972	3,753,895	18,364,373
Government	6,904	8,521	2,880	2,674	20,979
Total	37,385,342	49,011,743	66,180,549	47,479,294	200,056,928
2005					
Ag, Forestry, Fish	180,695	265,254	486,680	225,793	1,158,422
Mining	6,145	6,989	6,831	6,167	26,132
Construction	331,569	394,690	417,349	350,443	1,494,051
Manufacturing	189,774	408,360	755,371	324,673	1,678,178
Trans, Comm, Pub Util	3,303,609	3,247,424	3,176,215	3,499,416	13,226,664
Wholesale	118,866	262,964	265,290	146,946	794,066
Retail	30,080,856	41,791,331	57,508,271	40,989,959	170,370,417
Finance, Ins, Real Estate	964,192	1,088,803	1,194,048	1,052,583	4,299,626
Services	3,556,566	4,697,508	6,177,521	3,829,354	18,260,949
Government	1,897	8,502	11,907	3,079	25,385
Total	38,734,169	52,171,825	69,999,483	50,428,413	211,333,890
2006					
					Year to Date
Ag, Forestry, Fish	217,133	313,460			530,593
Mining	6,817	1,587			8,404
Construction	299,364	308,279			607,643
Manufacturing	201,996	385,863			587,859
Trans, Comm, Pub Util	3,792,216	3,284,609			7,076,825
Wholesale	133,091	263,156			396,247
Retail	32,500,881	44,029,453			76,530,334
Finance, Ins, Real Estate	1,050,738	1,107,265			2,158,003
Services	3,952,594	5,453,487			9,406,081
Government	11,248	13,251			24,499
Total	42,166,078	55,160,410			97,326,488

Table 6.8

Soldotna Construction

Soldotna 2nd Quarter Permit VALUES by Type - 2001-2006 - in \$

	2001	2002	2003	2004	2005	2006	Annual Change
Residential - New	2,363,001	2,075,293	1,899,354	1,777,087	1,916,999	2,116,499	10.4%
Residential - Add/Alter	151,039	339,286	130,080	74,809	141,950	140,730	-0.9%
Commercial - New	0	2,601,575	2,116,490	1,366,297	4,099,828	4,965,648	21.1%
Commercial - Add/Alter	717,150	1,987,304	88,000	530,380	673,458	8,451	-98.7%
TOTAL	3,231,190	7,003,458	4,233,924	3,748,573	6,832,235	7,231,328	5.8%
Annual Change		116.7%	-39.5%	-11.5%	82.3%	5.8%	

Table 6.9

Soldotna 2nd Quarter Permit VALUES by Type - 1986-2006

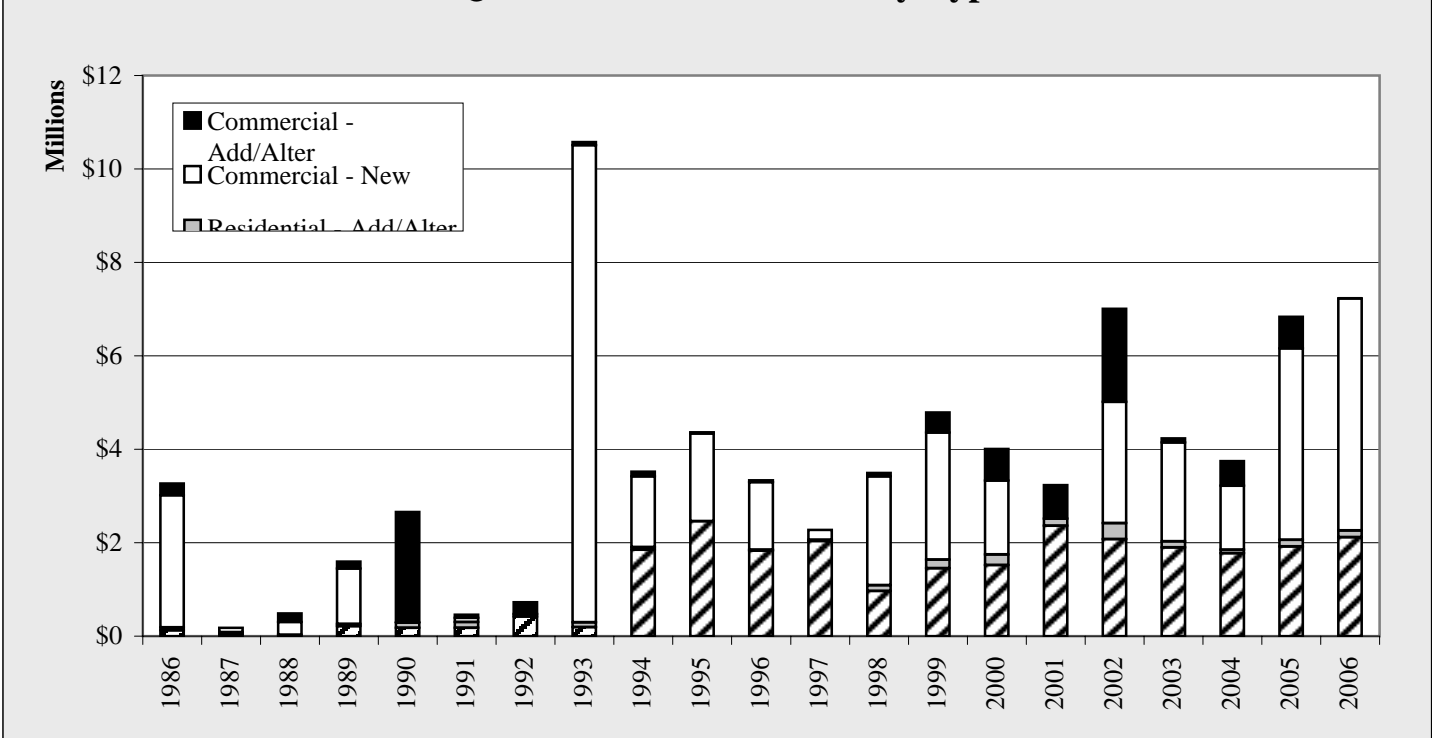

Chart 6.13

**Soldotna 2nd Quarter Permit VALUES
Percent by Type - 2006**

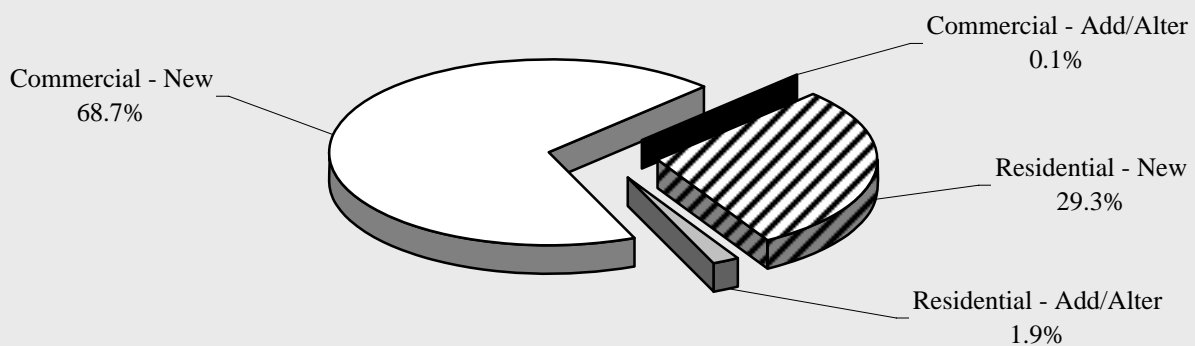

Chart 6.14

Soldotna Construction

Soldotna 2nd Quarter Permit VOLUME by Type - 2001-2006

	2001	2002	2003	2004	2005	2006	Annual Change
Residential - New	14	17	15	9	11	13	18.2%
Residential - Add/Alter	10	6	8	8	12	6	-50.0%
Commercial - New	0	9	6	3	9	5	-44.4%
Commercial - Add/Alter	13	19	7	6	8	1	-87.5%
TOTAL	37	51	36	26	40	25	-37.5%
Annual Change		37.8%	-29.4%	-27.8%	53.8%	-37.5%	

Table 6.10

Soldotna 2nd Quarter Permit VOLUME by Type - 1986-2006

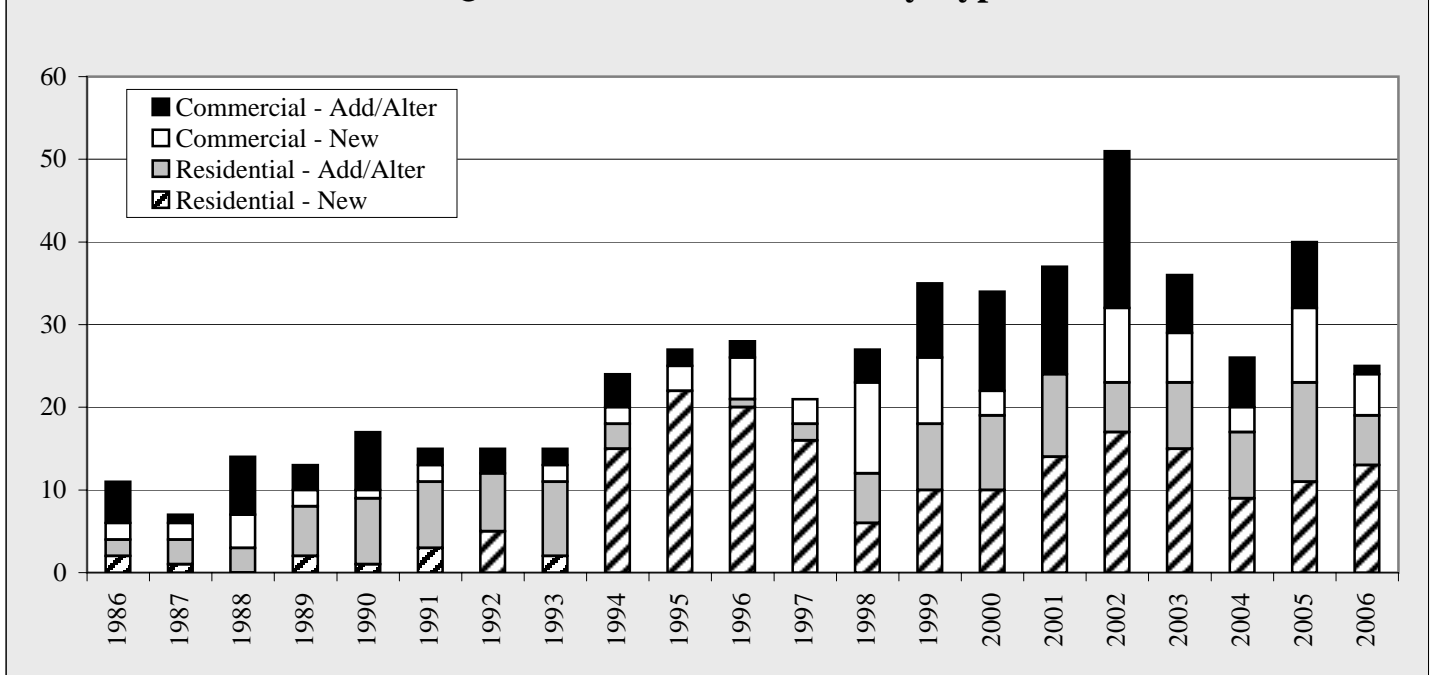

Chart 6.15

**Soldotna 2nd Quarter Permit VOLUME
Percent by Type - 2006**

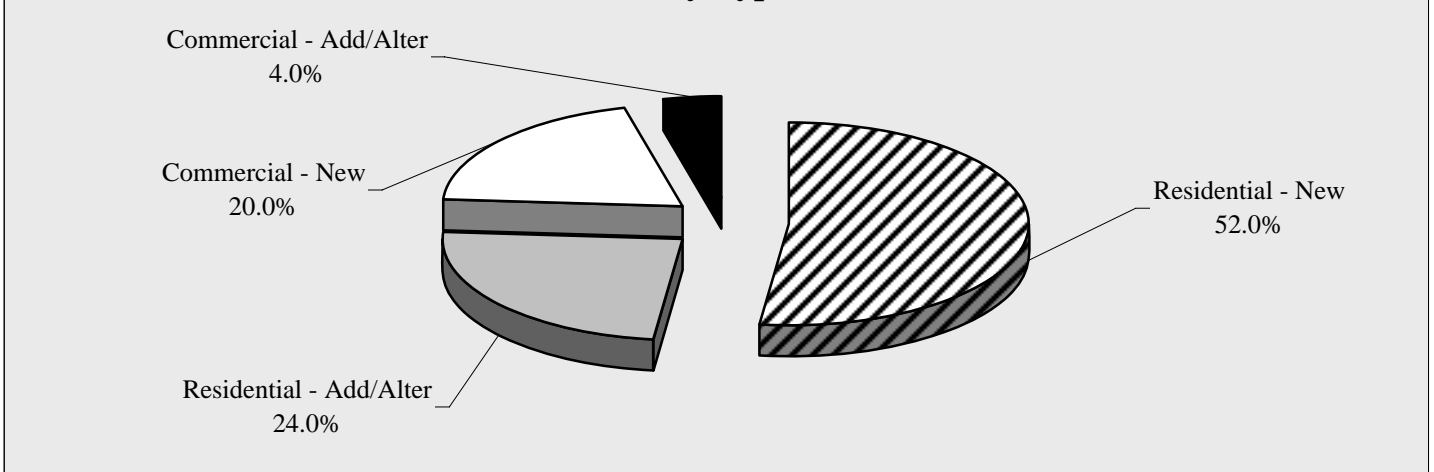

Chart 6.16

Soldotna Construction

Soldotna YTD 6/30 Permit VALUES by Type - 2001-2006 - in \$

	2001	2002	2003	2004	2005	2006	Annual Change
Residential - New	2,363,001	2,316,142	1,899,354	2,316,384	2,637,955	2,320,530	-12.0%
Residential - Add/Alter	256,199	426,221	187,907	74,809	403,580	150,730	-62.7%
Commercial - New	2,658,578	3,316,381	2,116,490	5,831,323	4,294,828	5,278,058	22.9%
Commercial - Add/Alter	1,004,630	2,150,304	457,191	590,380	917,427	1,598,451	74.2%
TOTAL	6,282,408	8,209,048	4,660,942	8,812,896	8,253,790	9,347,769	13.3%
Annual Change		30.7%	-43.2%	89.1%	-6.3%	13.3%	

Table 6.11

Soldotna YTD 6/30 Permit VALUES by Type - 1986-2006

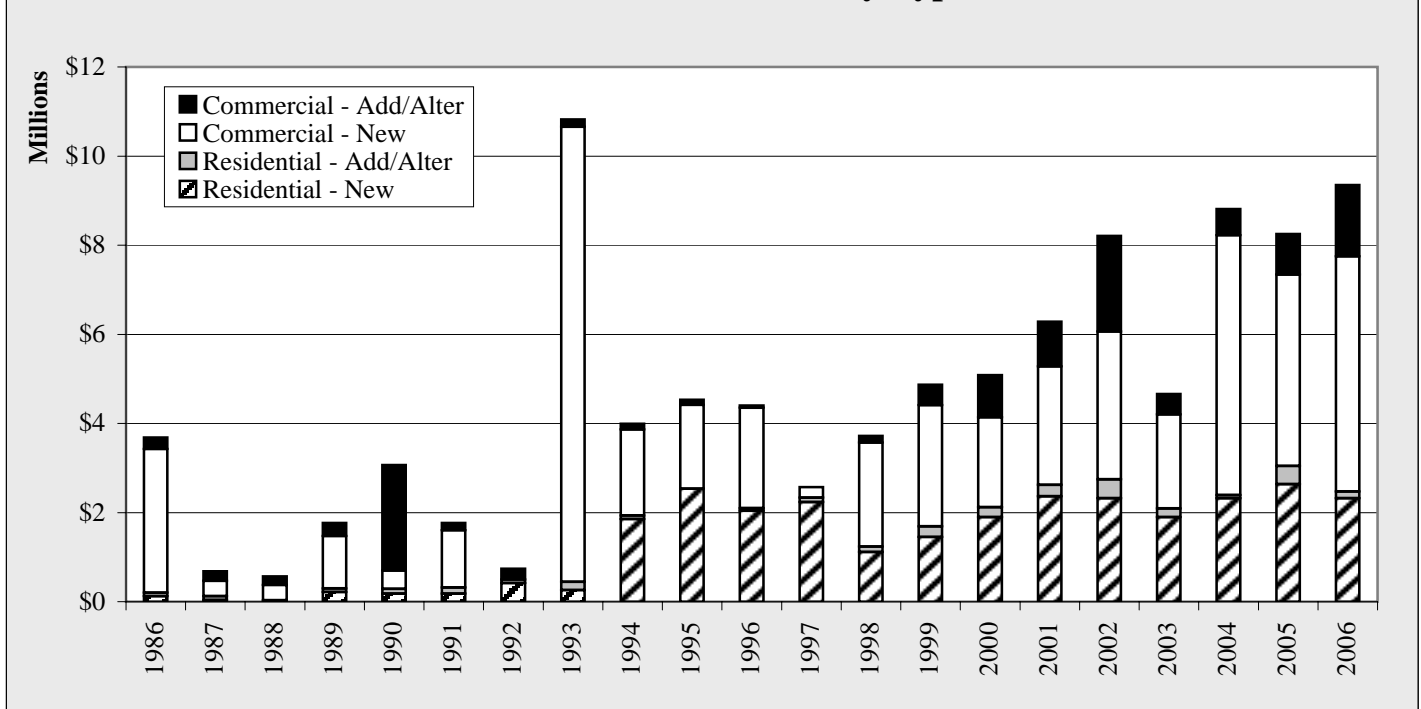

Chart 6.17

**Soldotna YTD 6/30 Permit VALUES
Percent by Type - 2006**

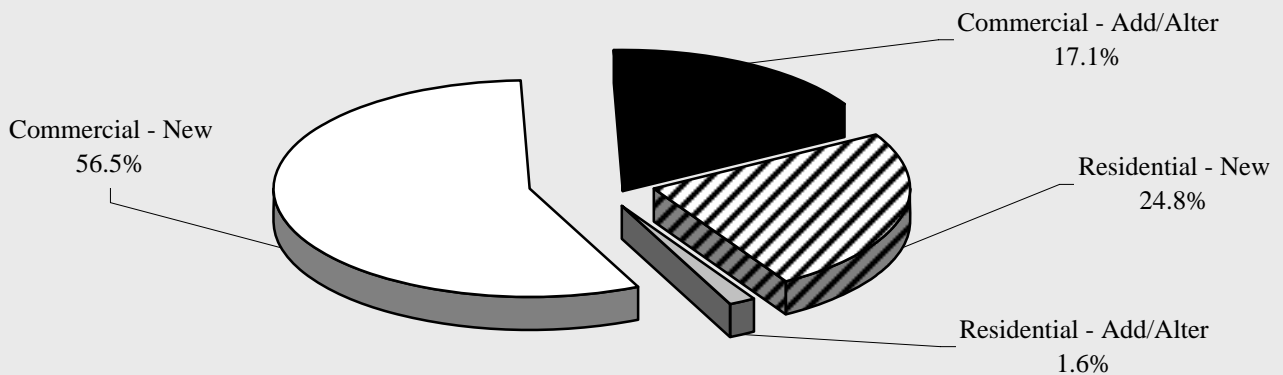

Chart 6.18

Soldotna Construction

Soldotna YTD 6/30 Permit VOLUME by Type - 2001-2006

	2001	2002	2003	2004	2005	2006	Annual Change
Residential - New	14	18	15	11	15	14	-6.7%
Residential - Add/Alter	13	8	11	8	15	7	-53.3%
Commercial - New	3	13	6	7	11	6	-45.5%
Commercial - Add/Alter	17	23	10	9	15	3	-80.0%
TOTAL	47	62	42	35	56	30	-46.4%
Annual Change		31.9%	-32.3%	-16.7%	60.0%	-46.4%	

Table 6.12

Soldotna YTD 6/30 Permit VOLUME by Type - 1986-2006

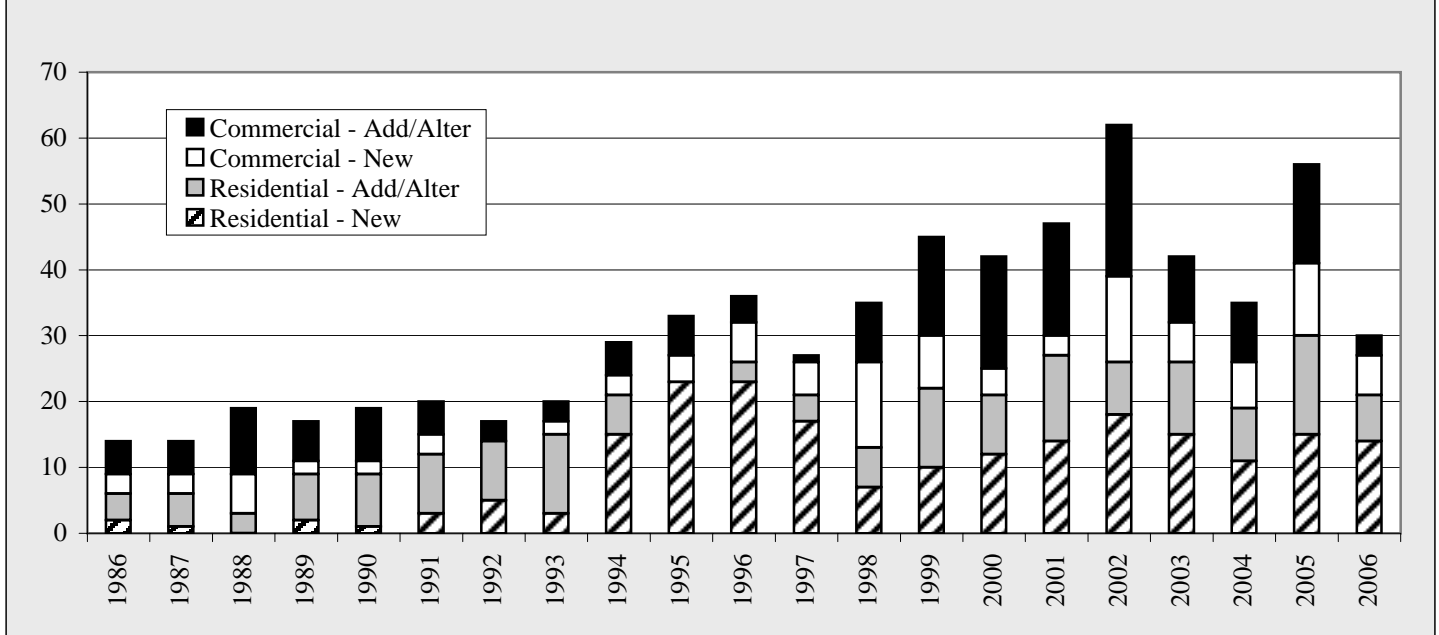

Chart 6.19

**Soldotna YTD 6/30 Permit VOLUME
Percent by Type - 2006**

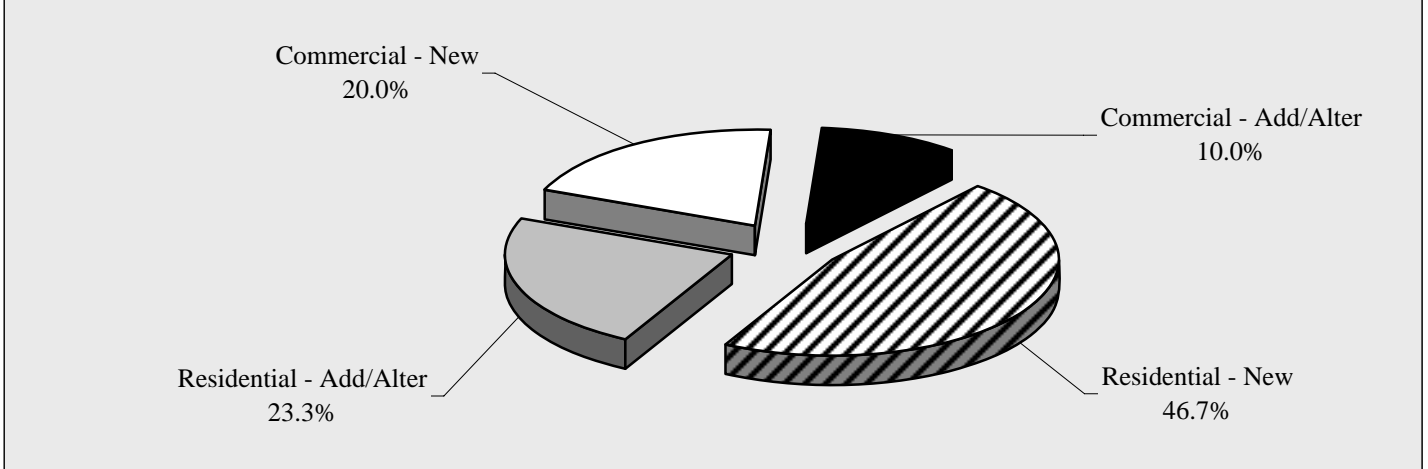

Chart 6.20

Soldotna Construction

Soldotna Annual Permit VALUES by Type by Quarter - 2000-2006 - in \$					
	1st Quarter	2nd Quarter	3rd Quarter	4th Quarter	Total
2000					
Residential - New	373,929	1,520,491	543,930	270,668	2,709,018
Residential - Add/Alter	0	224,674	101,065	39,500	365,239
Commercial - New	434,273	1,583,642	935,665	970,484	3,924,064
Commercial - Add/Alter	270,000	680,549	96,250	122,300	1,169,099
TOTAL	1,078,202	4,009,356	1,676,910	1,402,952	8,167,420
2001					
Residential - New	0	2,363,001	1,510,852	0	3,873,853
Residential - Add/Alter	105,160	151,039	50,148	51,148	357,495
Commercial - New	2,658,578	0	630,244	0	3,288,822
Commercial - Add/Alter	287,480	717,150	318,672	111,500	1,434,802
TOTAL	3,051,218	3,231,190	2,509,916	162,648	8,954,972
2002					
Residential - New	240,849	2,075,293	689,202	176,000	3,181,344
Residential - Add/Alter	86,935	339,286	317,466	11,500	755,187
Commercial - New	714,806	2,601,575	1,080,678	0	4,397,059
Commercial - Add/Alter	163,000	1,987,304	610,000	70,000	2,830,304
TOTAL	1,205,590	7,003,458	2,697,346	257,500	11,163,894
2003					
Residential - New	0	1,899,354	648,388	526,191	3,073,933
Residential - Add/Alter	57,827	130,080	70,722	5,000	263,629
Commercial - New	0	2,116,490	1,371,200	281,491	3,769,181
Commercial - Add/Alter	369,191	88,000	328,000	60,363	845,554
TOTAL	427,018	4,233,924	2,418,310	873,045	7,952,297
2004					
Residential - New	539,297	1,777,087	1,270,100	294,860	3,881,344
Residential - Add/Alter	0	74,809	145,721	57,454	277,984
Commercial - New	4,465,026	1,366,297	21,996,101	501,601	28,329,025
Commercial - Add/Alter	60,000	530,380	368,193	3,850,000	4,808,573
TOTAL	5,064,323	3,748,573	23,780,115	4,703,915	37,296,926
2005					
Residential - New	720,956	1,916,999	1,295,670	165,123	4,098,748
Residential - Add/Alter	261,630	141,950	88,410	2,000	493,990
Commercial - New	195,000	4,099,828	1,520,000	0	5,814,828
Commercial - Add/Alter	243,969	673,458	181,650	2,717	1,101,794
TOTAL	1,421,555	6,832,235	3,085,730	169,840	11,509,360
2006					
					Year to Date
Residential - New	204,031	2,116,499			2,320,530
Residential - Add/Alter	10,000	140,730			150,730
Commercial - New	312,410	4,965,648			5,278,058
Commercial - Add/Alter	1,590,000	8,451			1,598,451
TOTAL	2,116,441	7,231,328			9,347,769

Table 6.13

Soldotna Construction

Soldotna Annual Permit VOLUME by Type by Quarter - 2000-2006					
	1st Quarter	2nd Quarter	3rd Quarter	4th Quarter	Total
2000					
Residential - New	2	10	5	2	19
Residential - Add/Alter	0	9	7	3	19
Commercial - New	1	3	7	7	18
Commercial - Add/Alter	5	12	7	8	32
TOTAL	8	34	26	20	88
2001					
Residential - New	0	14	10	0	24
Residential Add/Alter	3	10	6	4	23
Commercial - New	3	0	7	0	10
Commercial - Add/Alter	4	13	12	7	36
TOTAL	10	37	35	11	93
2002					
Residential - New	1	17	5	1	24
Residential Add/Alter	2	6	10	2	20
Commercial - New	4	9	5	0	18
Commercial - Add/Alter	4	19	5	1	29
TOTAL	11	51	25	4	91
2003					
Residential - New	0	15	4	5	24
Residential Add/Alter	3	8	4	1	16
Commercial - New	0	6	8	2	16
Commercial - Add/Alter	3	7	3	5	18
TOTAL	6	36	19	13	74
2004					
Residential - New	2	9	7	1	19
Residential Add/Alter	0	8	6	3	17
Commercial - New	4	3	4	2	13
Commercial - Add/Alter	3	6	7	2	18
TOTAL	9	26	24	8	67
2005					
Residential - New	4	11	7	1	23
Residential Add/Alter	3	12	7	1	23
Commercial - New	2	9	2	0	13
Commercial - Add/Alter	7	8	4	3	22
TOTAL	16	40	20	5	81
2006					
	Year to Date				
Residential - New	1	13			14
Residential Add/Alter	1	6			7
Commercial - New	1	5			6
Commercial - Add/Alter	2	1			3
TOTAL	5	25			30

Table 6.14

Other KPB Sales

Other KPB 2nd Quarter GROSS Sales by Industry - 2001-2006 - in \$							
	2001	2002	2003	2004	2005	2006	Annual Change
Ag, Forest, Fish	1,133,165	1,142,492	2,042,231	1,256,193	1,540,365	1,634,372	6.1%
Mining	25,603,580	29,103,164	24,039,296	29,692,204	34,249,462	46,638,391	36.2%
Construction	26,755,464	30,739,954	35,928,211	22,794,483	29,497,240	27,296,506	-7.5%
Manufacturing	46,327,693	34,871,253	22,050,431	7,606,427	50,610,482	42,910,775	-15.2%
Trans, Comm, Public Utility	17,129,688	18,167,731	15,634,861	16,722,028	19,105,032	20,914,873	9.5%
Wholesale	25,989,525	28,469,316	29,652,374	28,462,396	18,499,445	21,784,527	17.8%
Retail	41,399,338	40,488,670	46,327,872	45,707,167	49,562,932	50,111,222	1.1%
Finance, Ins, Real Estate	4,648,250	3,742,527	4,594,592	3,981,211	5,128,597	4,657,067	-9.2%
Services	28,661,264	29,189,215	27,937,740	31,237,016	33,456,884	32,831,451	-1.9%
Government	0	0	0	0	0	0	NA
Total	217,647,967	215,914,322	208,207,608	187,459,125	241,650,439	248,779,184	3.0%
Annual Change		-0.8%	-3.6%	-10.0%	28.9%	3.0%	

Table 7.1

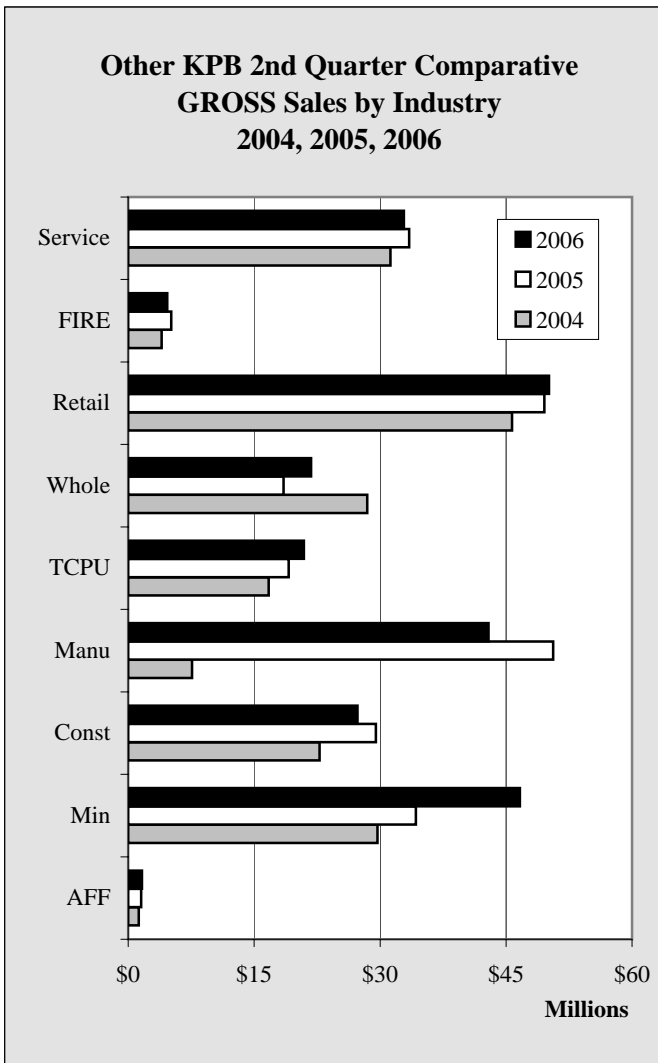

Chart 7.1

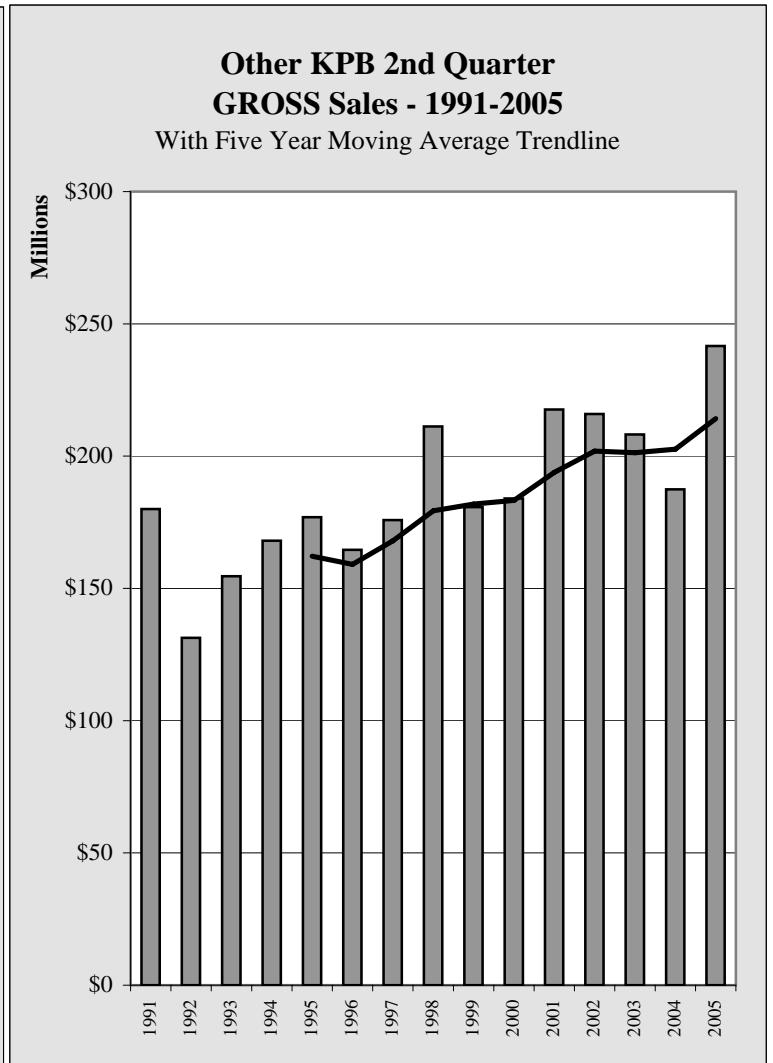

Chart 7.2

Other KPB Sales

Other KPB 2nd Quarter TAXABLE Sales by Industry - 2001-2006 - in \$							
	2001	2002	2003	2004	2005	2006	Annual Change
Ag, Forest, Fish	755,318	780,587	859,055	915,588	957,059	964,737	0.8%
Mining	1,265,086	1,417,403	1,114,615	1,018,997	976,689	1,098,900	12.5%
Construction	1,568,794	1,655,737	1,889,309	1,723,460	1,930,397	1,798,696	-6.8%
Manufacturing	892,944	881,441	792,161	785,263	935,107	755,707	-19.2%
Trans, Comm, Public Utility	9,844,493	11,314,077	9,184,673	8,908,793	11,375,972	12,586,688	10.6%
Wholesale	2,722,910	2,805,871	2,930,861	2,862,301	2,911,677	3,665,361	25.9%
Retail	24,014,664	23,268,264	25,347,109	24,642,219	25,443,978	26,488,460	4.1%
Finance, Ins, Real Estate	1,692,258	1,628,536	1,841,358	1,725,956	1,839,374	1,714,875	-6.8%
Services	15,114,615	13,763,563	14,342,153	15,806,419	16,962,727	16,823,709	-0.8%
Government	0	0	0	0	0	0	NA
Total	57,871,082	57,515,479	58,301,294	58,388,996	63,332,980	65,897,133	4.0%
Annual Change		-0.6%	1.4%	0.2%	8.5%	4.0%	

Table 7.2

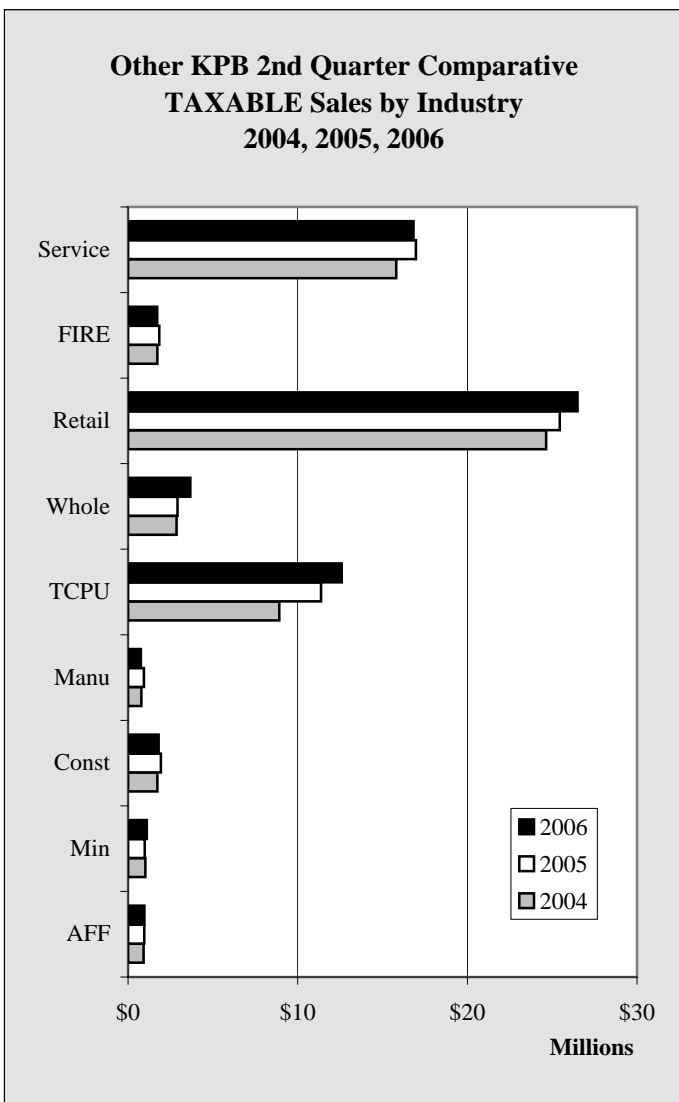

Chart 7.3

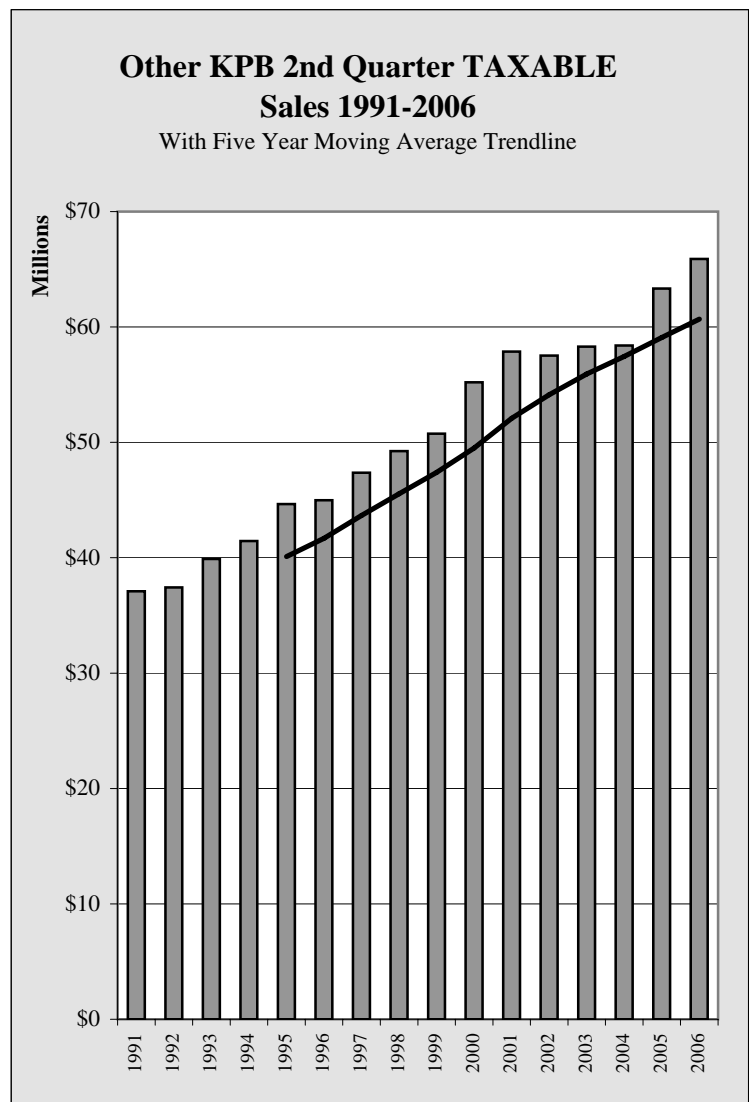

Chart 7.4

Other KPB Sales

Other KPB YTD 6/30 GROSS Sales by Industry - 2001-2006 - in \$							
	2001	2002	2003	2004	2005	2006	Annual Change
Ag, Forest, Fish	1,678,643	1,590,143	2,487,316	1,694,447	2,021,399	2,237,913	10.7%
Mining	52,852,431	61,402,416	42,178,318	67,364,432	71,714,764	89,872,586	25.3%
Construction	48,462,080	55,389,661	57,900,419	37,931,826	51,529,538	46,578,448	-9.6%
Manufacturing	87,384,091	49,825,823	53,712,724	29,549,699	80,689,022	59,326,199	-26.5%
Trans, Comm, Public Utility	33,850,617	36,588,703	30,232,931	31,681,467	38,010,479	42,301,805	11.3%
Wholesale	46,261,644	50,412,457	50,600,896	50,494,264	43,655,113	38,467,844	-11.9%
Retail	68,572,844	69,242,603	77,103,516	75,716,751	79,942,588	83,158,984	4.0%
Finance, Ins, Real Estate	7,916,561	6,963,861	7,448,189	7,755,380	8,393,380	8,943,776	6.6%
Services	41,219,266	43,936,788	40,912,579	44,435,010	48,725,689	48,073,940	-1.3%
Government	0	0	0	6,365	13,317	0	-100.0%
Total	388,198,177	375,352,455	362,576,888	346,629,641	424,695,289	418,961,495	-1.4%
Annual Change		-3.3%	-3.4%	-4.4%	22.5%	-1.4%	

Table 7.3

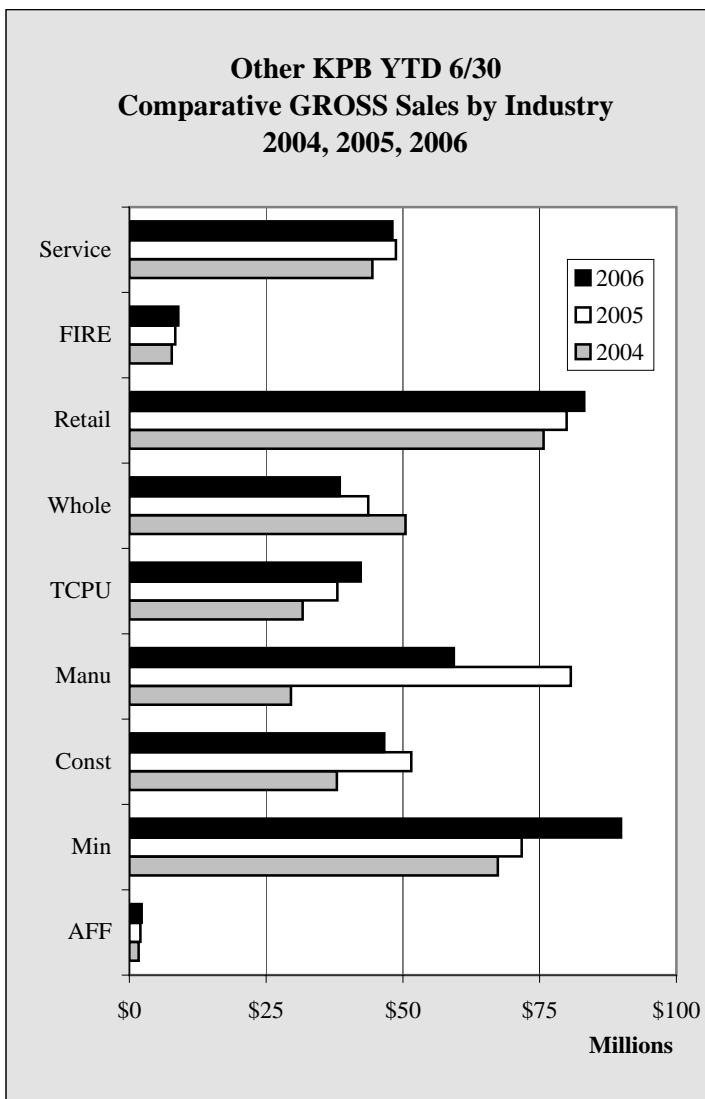

Chart 7.5

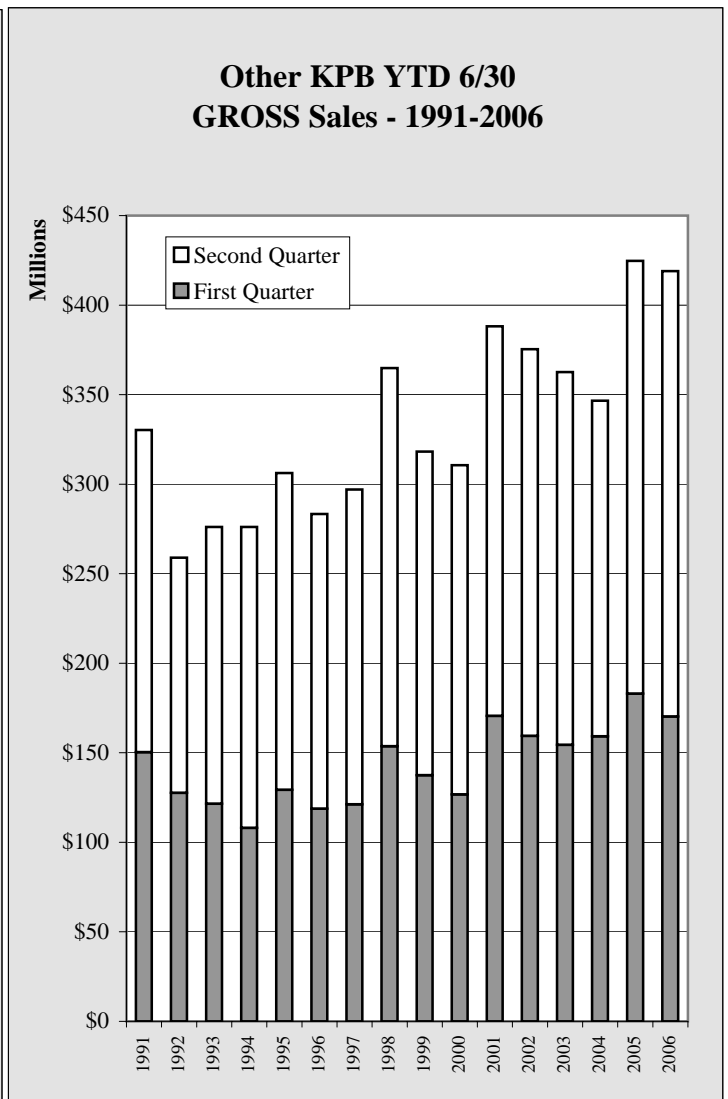

Chart 7.6

Other KPB Sales

Other KPB YTD 6/30 TAXABLE Sales by Industry - 2001-2006 - in \$							
	2001	2002	2003	2004	2005	2006	Annual Change
Ag, Forest, Fish	1,099,152	1,177,104	1,219,206	1,318,479	1,386,137	1,464,197	5.6%
Mining	2,424,873	2,841,477	2,304,740	1,996,163	1,988,156	2,058,936	3.6%
Construction	2,647,523	2,786,694	3,031,623	2,903,620	3,106,222	2,944,269	-5.2%
Manufacturing	1,301,057	1,278,092	1,147,304	1,153,164	1,343,557	1,091,749	-18.7%
Trans, Comm, Public Utility	20,282,481	23,454,900	19,101,385	19,167,428	23,742,031	26,915,977	13.4%
Wholesale	5,303,572	5,725,365	5,704,576	6,190,487	6,125,822	7,217,479	17.8%
Retail	39,284,302	39,578,919	41,485,432	40,706,070	41,351,165	44,388,491	7.3%
Finance, Ins, Real Estate	3,020,218	3,136,810	3,295,960	3,238,749	3,257,771	3,190,099	-2.1%
Services	20,563,163	19,397,102	19,397,941	20,786,833	22,154,607	22,513,076	1.6%
Government	0	0	0	6,300	13,317	0	NA
Total	95,926,341	99,376,463	96,688,167	97,467,293	104,468,785	111,784,273	7.0%
Annual Change		3.6%	-2.7%	0.8%	7.2%	7.0%	

Table 7.4

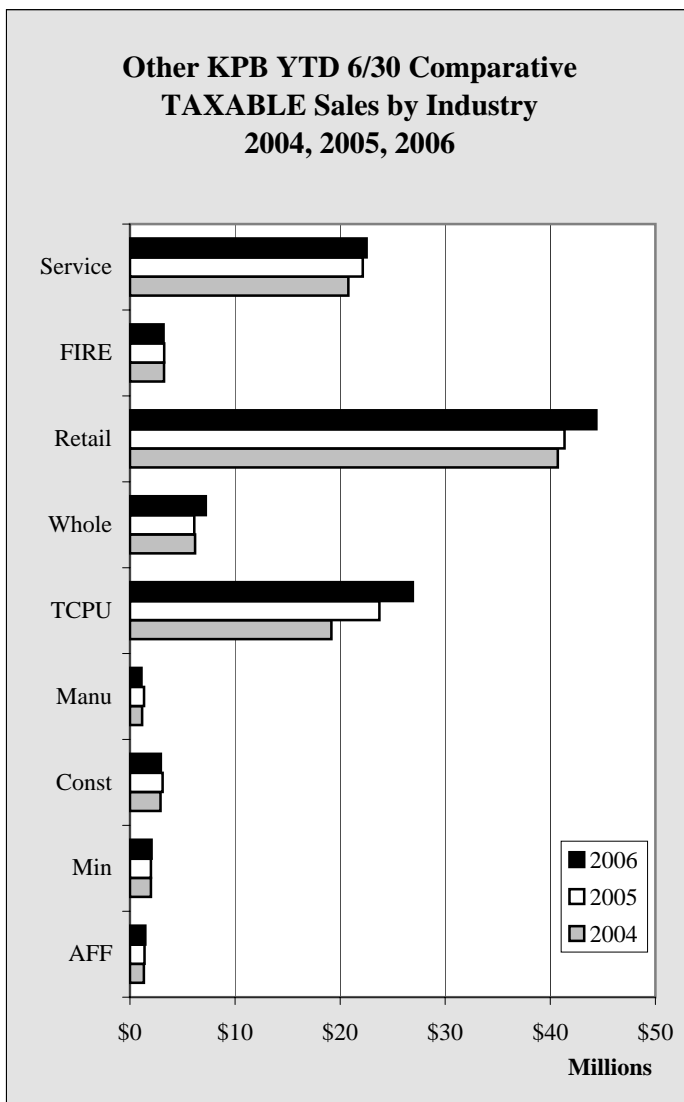

Chart 7.7

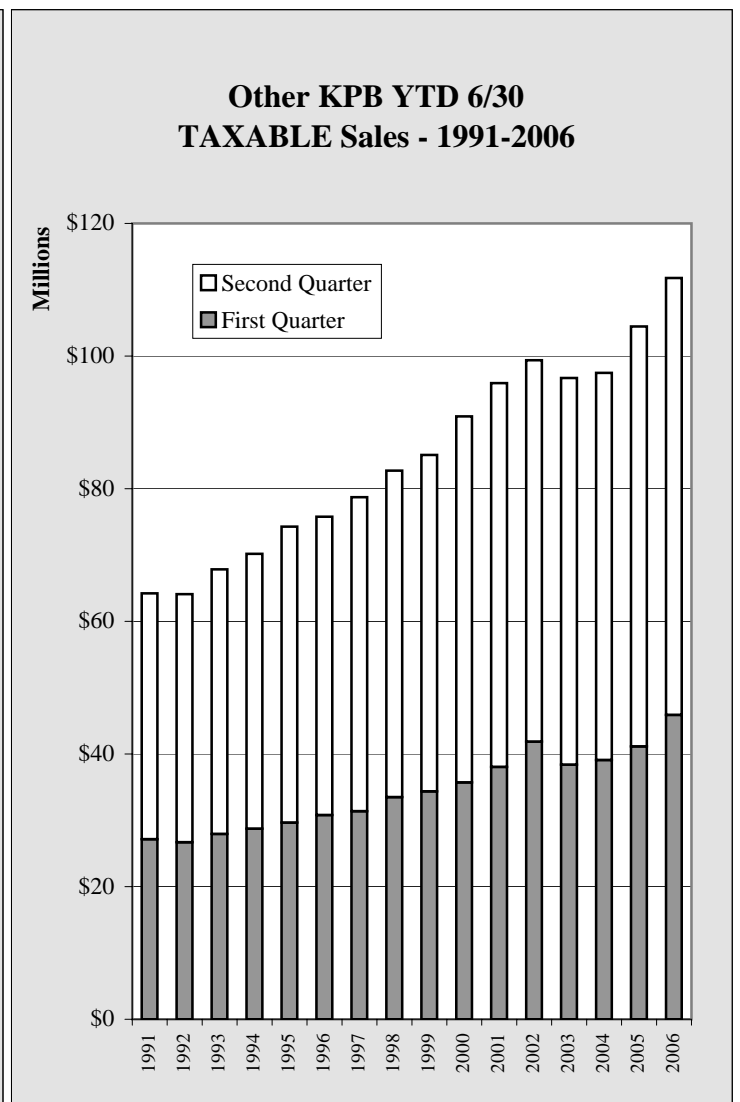

Chart 7.8

Other KPB Sales

Other KPB Annual GROSS Sales by Industry - 2000-2005 - in \$							
	2000	2001	2002	2003	2004	2005	Annual Change
Ag, Forest, Fish	2,875,629	3,242,403	4,090,590	4,814,409	5,857,634	6,886,103	17.6%
Mining	115,625,431	123,091,789	108,808,400	101,004,267	155,698,225	165,602,265	6.4%
Construction	88,853,048	136,499,774	131,271,956	133,817,324	130,423,015	134,499,339	3.1%
Manufacturing	85,638,574	250,593,511	164,080,370	159,471,272	143,967,105	199,927,987	38.9%
Trans, Comm, Public Utility	66,837,538	77,388,092	73,138,015	63,786,231	78,102,991	82,727,983	5.9%
Wholesale	101,310,365	104,710,505	108,334,825	115,986,698	282,122,850	290,451,055	3.0%
Retail	138,967,225	153,029,767	155,144,994	166,739,518	167,774,505	175,139,902	4.4%
Finance, Ins, Real Estate	13,106,195	15,680,221	14,490,692	16,516,352	19,497,141	21,125,960	8.4%
Services	95,090,680	100,412,737	103,289,678	99,635,983	115,306,004	120,025,587	4.1%
Government	0	0	0	0	13,732	13,422	NA
Total	708,304,685	964,648,799	862,649,520	861,772,054	1,098,763,202	1,196,399,603	8.9%
Annual Change		36.2%	-10.6%	-0.1%	27.5%	8.9%	

Table 7.5

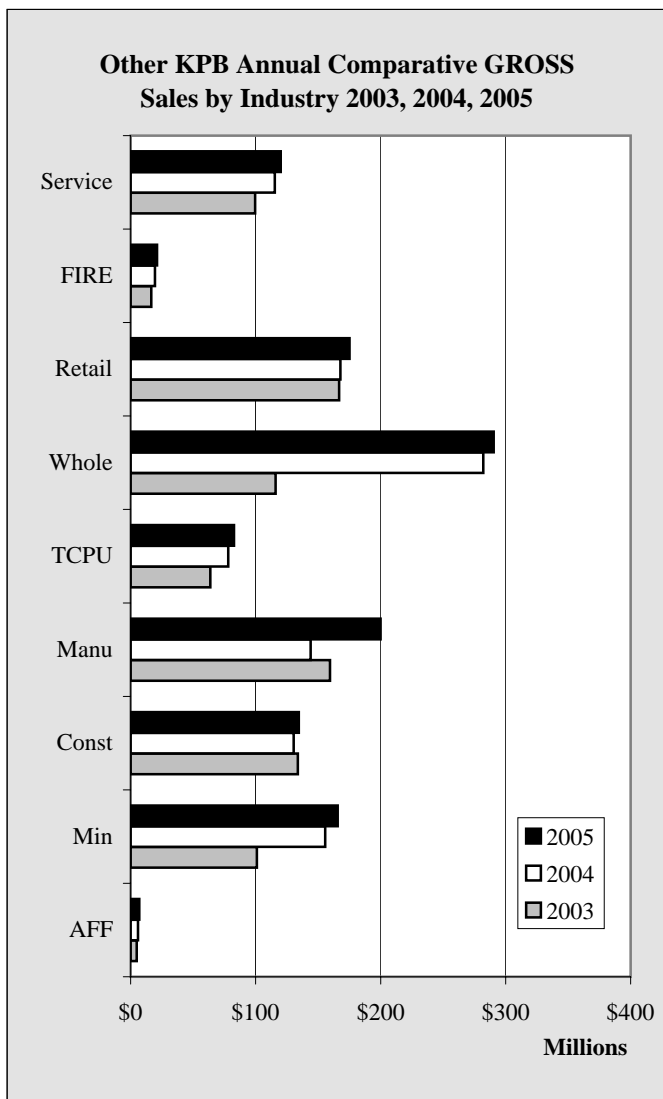

Chart 7.9

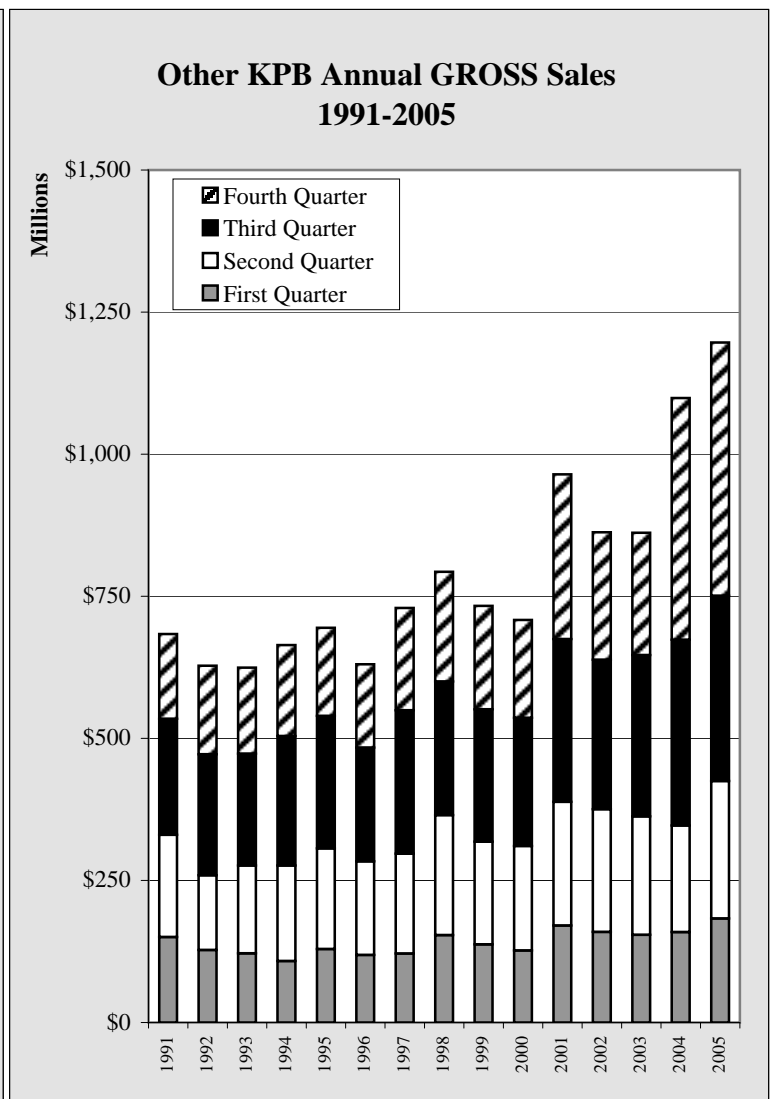

Chart 7.10

Other KPB Sales

Other KPB Annual TAXABLE Sales by Industry - 2000-2005 - in \$							
	2000	2001	2002	2003	2004	2005	Annual Change
Ag, Forest, Fish	1,945,844	2,016,782	2,152,460	2,281,300	2,540,907	2,751,728	8.3%
Mining	4,434,095	5,598,954	5,598,990	4,655,675	5,218,907	4,205,059	-19.4%
Construction	5,735,340	6,115,447	6,564,874	6,597,575	6,756,897	6,722,157	-0.5%
Manufacturing	3,084,591	3,041,030	2,948,674	2,626,320	2,872,294	3,098,966	7.9%
Trans, Comm, Public Utility	39,092,526	42,147,135	41,606,993	37,098,365	40,099,801	47,579,101	18.7%
Wholesale	11,100,421	11,675,046	11,654,301	12,058,985	12,951,451	13,367,532	3.2%
Retail	80,838,970	85,853,411	86,163,132	89,676,971	88,813,149	92,179,867	3.8%
Finance, Ins, Real Estate	5,678,461	6,363,047	6,513,758	7,046,790	6,797,500	7,258,902	6.8%
Services	47,432,032	48,734,123	47,513,154	47,663,284	52,444,327	55,703,462	6.2%
Government	0	0	0	0	13,667	13,422	NA
Total	199,342,280	211,544,975	210,716,336	209,705,265	218,508,900	232,880,196	6.6%
Annual Change		6.1%	-0.4%	-0.5%	4.2%	6.6%	

Table 7.6

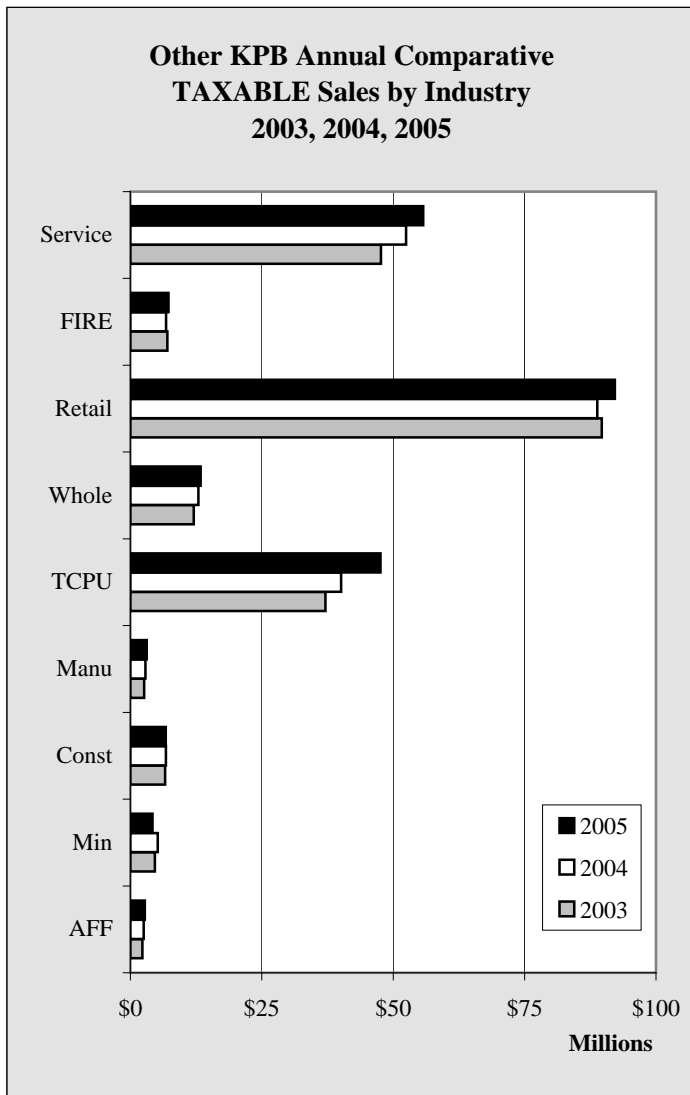

Chart 7.11

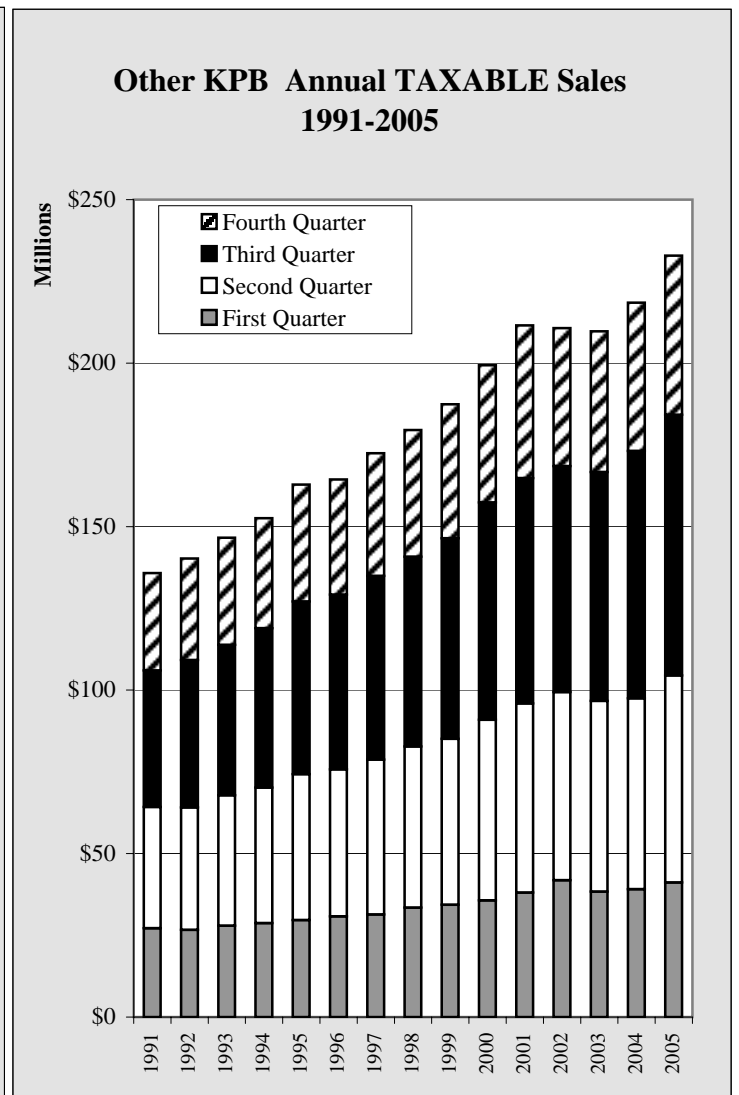

Chart 7.12

Other KPB Sales

Other KPB GROSS Sales by Industry by Quarter - 2003-2006 - in \$					
	1st Quarter	2nd Quarter	3rd Quarter	4th Quarter	Total
2003					
Ag, Forest, Fish	445,085	2,042,231	1,578,920	748,173	4,814,409
Mining	18,139,022	24,039,296	28,701,184	30,124,765	101,004,267
Construction	21,972,208	35,928,211	44,783,625	31,133,280	133,817,324
Manufacturing	31,662,293	22,050,431	53,343,537	52,415,011	159,471,272
Trans, Comm, Public Utility	14,598,070	15,634,861	18,568,068	14,985,232	63,786,231
Wholesale	20,948,522	29,652,374	37,077,443	28,308,359	115,986,698
Retail	30,775,644	46,327,872	52,439,119	37,196,883	166,739,518
Finance, Ins, Real Estate	2,853,597	4,594,592	5,140,046	3,928,117	16,516,352
Services	12,974,839	27,937,740	42,276,842	16,446,562	99,635,983
Government	0	0	0	0	0
Total	154,369,280	208,207,608	283,908,784	215,286,382	861,772,054
2004					
Ag, Forest, Fish	438,254	1,256,193	1,632,207	2,530,980	5,857,634
Mining	37,672,228	29,692,204	36,588,670	51,745,123	155,698,225
Construction	15,137,343	22,794,483	37,203,422	55,287,767	130,423,015
Manufacturing	21,943,272	7,606,427	87,311,541	27,105,865	143,967,105
Trans, Comm, Public Utility	14,959,439	16,722,028	20,217,590	26,203,934	78,102,991
Wholesale	22,031,868	28,462,396	36,327,578	195,301,008	282,122,850
Retail	30,009,584	45,707,167	54,330,388	37,727,366	167,774,505
Finance, Ins, Real Estate	3,774,169	3,981,211	4,894,601	6,847,160	19,497,141
Services	13,197,994	31,237,016	48,196,176	22,674,818	115,306,004
Government	6,365	0	6,304	1,063	13,732
Total	159,170,516	187,459,125	326,708,477	425,425,084	1,098,763,202
2005					
Ag, Forest, Fish	481,034	1,540,365	1,237,008	3,627,696	6,886,103
Mining	37,465,302	34,249,462	42,385,676	51,501,825	165,602,265
Construction	22,032,298	29,497,240	37,430,216	45,539,585	134,499,339
Manufacturing	30,078,540	50,610,482	86,445,717	32,793,248	199,927,987
Trans, Comm, Public Utility	18,905,447	19,105,032	22,745,986	21,971,518	82,727,983
Wholesale	25,155,668	18,499,445	23,074,120	223,721,822	290,451,055
Retail	30,379,656	49,562,932	55,583,775	39,613,539	175,139,902
Finance, Ins, Real Estate	3,264,783	5,128,597	6,431,945	6,300,635	21,125,960
Services	15,268,805	33,456,884	50,927,057	20,372,841	120,025,587
Government	13,317	0	0	105	13,422
Total	183,044,850	241,650,439	326,261,500	445,442,814	1,196,399,603
2006					
				Year to Date	
Ag, Forest, Fish	603,541	1,634,372			2,237,913
Mining	43,234,195	46,638,391			89,872,586
Construction	19,281,942	27,296,506			46,578,448
Manufacturing	16,415,424	42,910,775			59,326,199
Trans, Comm, Public Utility	21,386,932	20,914,873			42,301,805
Wholesale	16,683,317	21,784,527			38,467,844
Retail	33,047,762	50,111,222			83,158,984
Finance, Ins, Real Estate	4,286,709	4,657,067			8,943,776
Services	15,242,489	32,831,451			48,073,940
Government	0	0			0
Total	170,182,311	248,779,184			418,961,495

Table 7.7

Other KPB Sales

Other KPB TAXABLE Sales by Industry by Quarter - 2003-2006 - in \$					
	1st Quarter	2nd Quarter	3rd Quarter	4th Quarter	Total
2003					
Ag, Forest, Fish	360,151	859,055	635,120	426,974	2,281,300
Mining	1,190,125	1,114,615	1,252,874	1,098,061	4,655,675
Construction	1,142,314	1,889,309	2,022,587	1,543,365	6,597,575
Manufacturing	355,143	792,161	968,694	510,322	2,626,320
Trans, Comm, Public Utility	9,916,712	9,184,673	8,687,138	9,309,842	37,098,365
Wholesale	2,773,715	2,930,861	3,197,783	3,156,626	12,058,985
Retail	16,138,323	25,347,109	28,917,038	19,274,501	89,676,971
Finance, Ins, Real Estate	1,454,602	1,841,358	2,239,195	1,511,635	7,046,790
Services	5,055,788	14,342,153	22,055,123	6,210,220	47,663,284
Government	0	0	0	0	0
Total	38,386,873	58,301,294	69,975,552	43,041,546	209,705,265
2004					
Ag, Forest, Fish	402,891	915,588	748,068	474,360	2,540,907
Mining	977,166	1,018,997	1,829,645	1,393,099	5,218,907
Construction	1,180,160	1,723,460	2,105,131	1,748,146	6,756,897
Manufacturing	367,901	785,263	1,215,828	503,302	2,872,294
Trans, Comm, Public Utility	10,258,635	8,908,793	10,037,127	10,895,246	40,099,801
Wholesale	3,328,186	2,862,301	3,238,122	3,522,842	12,951,451
Retail	16,063,851	24,642,219	29,294,147	18,812,932	88,813,149
Finance, Ins, Real Estate	1,512,793	1,725,956	1,987,422	1,571,329	6,797,500
Services	4,980,414	15,806,419	25,173,854	6,483,640	52,444,327
Government	6,300	0	6,304	1,063	13,667
Total	39,078,297	58,388,996	75,635,648	45,405,959	218,508,900
2005					
Ag, Forest, Fish	429,078	957,059	857,567	508,024	2,751,728
Mining	1,011,467	976,689	1,026,180	1,190,723	4,205,059
Construction	1,175,825	1,930,397	2,027,235	1,588,700	6,722,157
Manufacturing	408,450	935,107	1,208,266	547,143	3,098,966
Trans, Comm, Public Utility	12,366,059	11,375,972	11,479,271	12,357,799	47,579,101
Wholesale	3,214,145	2,911,677	3,491,150	3,750,560	13,367,532
Retail	15,907,187	25,443,978	30,471,216	20,357,486	92,179,867
Finance, Ins, Real Estate	1,418,397	1,839,374	2,251,850	1,749,281	7,258,902
Services	5,191,880	16,962,727	26,878,892	6,669,963	55,703,462
Government	13,317	0	0	105	13,422
Total	41,135,805	63,332,980	79,691,627	48,719,784	232,880,196
2006					
				Year to Date	
Ag, Forest, Fish	499,460	964,737			1,464,197
Mining	960,036	1,098,900			2,058,936
Construction	1,145,573	1,798,696			2,944,269
Manufacturing	336,042	755,707			1,091,749
Trans, Comm, Public Utility	14,329,289	12,586,688			26,915,977
Wholesale	3,552,118	3,665,361			7,217,479
Retail	17,900,031	26,488,460			44,388,491
Finance, Ins, Real Estate	1,475,224	1,714,875			3,190,099
Services	5,689,367	16,823,709			22,513,076
Government	0	0			0
Total	45,887,140	65,897,133			111,784,273

Table 7.8

KPB Local Officials Directory

Officials of the various governing bodies within the Kenai Peninsula Borough are listed on the following pages.

The officials listed are those who held office at the time of printing of the report. Annual elections for public officials are held each October. For information regarding current public officials, check the appropriate website.

Kenai Peninsula Borough – <http://www.borough.kenai.ak.us/>

Kenai Peninsula Borough School District – <http://www.kpbsd.k12.ak.us/>

City of Homer – <http://www.ci.homer.ak.us/>

City of Kenai – <http://www.ci.kenai.ak.us/>

City of Seldovia – <http://www.xyz.net/~seldovia/>

City of Seward – <http://www.cityofseward.net/>

City of Soldotna – <http://www.ci.soldotna.ak.us/>

KPB Local Officials Directory

Kenai Peninsula Borough Mayors

Kenai Peninsula Borough

Mayor John J. Williams 144 North Binkley
Soldotna, AK 99669
907-262-4441

City of Homer

Mayor Jim Hornady 491 East Pioneer Ave.
Homer, AK 99603
907-235-8121

City of Kachemak

Mayor Philemon Morris PO Box 598
Homer, AK 99603
907-235-8897

City of Kenai

Mayor Pat Porter 210 Fidalgo Street, Suite 200
Kenai, AK 99611
907-283-7535

City of Seldovia

Mayor Dick Wyland Drawer B
Seldovia, AK 99663
907-234-7643

City of Seward

Mayor Vanta Shafer PO Box 167
Seward, AK 99664
907-224-4046

City of Soldotna

Mayor Dave Carey 177 North Birch
Soldotna, AK 99669
907-262-9107

Table 8.1

KPB Local Officials Directory

<i>Kenai Peninsula Borough Mayor & Assembly</i>				
144 N. Binkley Soldotna, Alaska 99669 Phone 907-714-2160 Assembly/Clerk Fax: 907-714-2388 Assembly e-mail: assemblyclerk@borough.kenai.ak.us				
<i>Office / District</i>	<i>Name / Address</i>	<i>Phone / Fax / E-Mail</i>	<i>Term Expires</i>	<i>Previously Elected</i>
Borough Mayor	John Williams 144 N. Binkley St. Soldotna, AK 99669	714-2150 W 283-4960 H 262-8616 F jwilliams@borough.kenai.ak.us	2008	2005
Assembly 1 Kalifornsky	Dan Chay 37306 Cetacea Lane Kenai, AK 99611	283-9227 H 283-7588 F chay@alaska.com	2006	2003
Assembly 2 Kenai	Margaret Gilman 216 Susieana Lane Kenai, AK 99611	283-0860 H mbgilman@gci.net	2008	2005
Assembly 3 Nikiski	Gary Superman P.O. Box 8425 Nikiski, AK 99635	776-8448 H 776-8098 F 252-5264 W gsuperman@gci.net	2007	2001, 2004
Assembly 4 Soldotna	Pete Sprague - Vice President 188 Farnsworth Blvd. Soldotna, AK 99669	262-4073 H 262-8615 F psprague@acsalaska.net	2007	1998, 2001, 2002, 2004
Assembly 5 - Sterling / Funny River	Grace Merkes P.O. Box 8 Sterling, AK 99672	262-9811 H merkes2@yahoo.com	2008	1991, 1992, 1993, 1996, 1999, 2002, 2005
Assembly 6 East Peninsula	Ron Long - President P.O. Box 2464 Seward, AK 99664	224-7068 H 224-5707 F rlms@ptialaska.net	2006	2000, 2003
Assembly 7 Central	Paul Fischer P.O. Box 889 Kasilof, AK 99610	262-9269 H 262-4902 F akjfischer@hotmail.com	2007	1998, 2001, 2002, 2004
Assembly 8 Homer	Deb Germano P.O. Box 1511 Homer, AK 99603	235-2538 H debgermano@acsalaska.net	2008	2005
Assembly 9 South Peninsula	Milli Martin P.O. Box 2652 Homer, AK 99603	235-6652 H 235-6652 F millimom@xyz.net	2006	2000, 2002, 2003
Borough Clerk	Sherry Biggs 144 N. Binkley St. Soldotna, AK 99669	714-2160 262-8615 Fax assemblyclerk@borough.kenai.ak.us		

Table 8.2

KPB Local Officials Directory

KENAI PENINSULA BOROUGH		
PLANNING COMMISSION MEMBERS		
2006		
Member	Contact Information	Term Expires
CHAIRMAN		
Philip Bryson P.O. Box 1041 Kenai, Alaska 99611-1041	283-4672 work 283-4428 home	Kenai City Term Expires July 31, 2007
VICE CHAIRMAN		
Tom Clark P.O. Box 962 Anchor Point, Alaska 99556-0962	235-2887 home	Anchor Point/Ninilchik Term Expires July 31, 2007
Bonnie Heimbuch 987 Keystone Drive Soldotna, Alaska 99669	262-6887 - home	Soldotna City Term Expires July 31, 2008
Dr. Rick Foster P.O. Box 3328 Homer, AK 99603-3328	235-9100 - home	Homer City Term Expires July 31, 2007
Mari Anne Gross 57485 Clover Avenue Homer, Alaska 99603	235-7330 - home	Southwest Borough Term Expires July 31, 2008
Lynn Hohl P.O. Box 333 Seward, Alaska 99664-0333	224-7300 - home	Seward City Term Expires July 31, 2008
William Hutchinson P.O. Box 2585 Soldotna, Alaska 99669-2585	262-5256 - home	Ridgeway Term Expires July 31, 2007
James Isham P.O. Box 51 Soldotna, Alaska 99669-0051	262-9200 - home	Sterling Term Expires July 31, 2009
Brent Johnson 20773 Porcupine Lane Clam Gulch, Alaska 99568-9713	262-4763 - home	Kasilof/Clam Gulch Term Expires July 31, 2009
Blair Martin P.O. Box 1776 Soldotna, Alaska 99669-1776	283-5227 - home	Kalifornsky Beach Term Expires July 31, 2009
Paulette Bokenko-Carluccio P.O. Box 116 Seldovia, Alaska 99663-0278	234-3722 - home	Seldovia City Term Expires July 31, 2009
Todd Petersen P.O. Box 651 Seward, Alaska 99664-0651	288-5050 - home 224-3350 - work 224-2388 - work fax	East Peninsula Term Expires July 31, 2007
Ray Tauriainen P.O. Box 8678 Nikiski, Alaska 99635-8678	776-8885 - home	Northwest Borough Term Expires July 31, 2008

Email address for the Planning Commission: planning@borough.kenai.ak.us

Fax Number for the Planning Commission: 907-262-8618

Table 8.3

KPB Local Officials Directory

Kenai Peninsula Borough School District			
148 North Binkley Street Soldotna, AK 99669 907-262-5846			
<u>Board of Education</u>			
Debra Mullins, President	53630 Redoubt Drive Kenai, AK 99611	907-776-6360	Term Expires 2008
Sammie Crawford, Vice President	36615 Chinulna Drive Kenai, AK 99611	904-283-9271	Term Expires 2007
Sandra Wassilie, Clerk	P.O. Box 1576 Seward, AK 99664	907-224-3950	Term Expires 2007
Bill Hatch	P.O. Box 2305 Kenai, AK 99611	907-283-5122	Term Expires 2006
Marty Anderson	P.O. Box 1388 Sterling, AK 99672	907-260-7500	Term Expires 2006
Nels Anderson, MD	303 Diane Lane Soldotna, AK 99669	907-262-3280	Term Expires 2008
Debbie Brown	P.O. Box 592 Kasilof, AK 99610	907-262-4551	Term Expires 2008
Elizabeth Downing	1247 Bay Avenue Homer, AK 99603	907-235-8555	Term Expires 2006
Sunni Hilts	P.O. Box 144 Seldovia, AK 99663	907-234-7692	Term Expires 2007
Student Representative Kelly King	Soldotna High School 425 W. Marydale Ave. Soldotna, AK 99669		Term Expires 9/2006

Table 8.4

<u>Administration</u>
Dr. Donna Peterson, Superintendent of Schools Sam Stewart, Assistant Superintendent Glen Szymoniak, Assistant Superintendent of Instruction Melody Douglas, Chief Financial Officer Tim Peterson, Director of Human Resources

Table 8.5

KPB Local Officials Directory

Kenai Peninsula Borough Department Directors

Switchboard	262-4441
Assessing	Shane Horan
Capital Projects	Rob Robson
Clerk	Sherry Biggs
Finance	Craig Chapman
Legal	Colette Thompson
Maintenance	Bill Kopecky
Resource Planning	Max Best
Road Maintenance	Gary Davis
Solid Waste	Bob Garlock

Table 8.6

Kenai Peninsula Borough Economic Development Agencies
Kenai Peninsula Economic Development District - EDD 14790 Kenai Spur Highway, Ste. 106A Kenai, AK 99611 907-283-3335
Kenai Peninsula Tourism Marketing Council 35477 Kenai Spur Highway, Ste 205 Soldotna, AK 99669 907-262-5229
Kenai Peninsula Resource Conservation and Development, Inc. Trading Bay Plaza, Suite 150 PO Box 800, Kenai, AK 99611 907-283-7493

Table 8.7