



KENAI PENINSULA BOROUGH
QUARTERLY REPORT
OF KEY ECONOMIC INDICATORS

For Fiscal Quarter Ending December 31, 2008
Published March, 2009

David R. Carey
Borough Mayor

Compiled and Produced By
Jeanne Camp, Economic Analyst
144 North Binkley Street
Soldotna, Alaska 99669
Phone – 907-714-2336

See this document on the web – <http://www.borough.kenai.ak.us>
Use the 'Economic Analysis' link, select 'Publications.'

Index

#	Page
Introduction	2
Executive Summary	4
Kenai Peninsula Borough	
Sales – KPB Finance Department	13
Construction – Cities of Homer, Kenai, Seldovia, Seward and Soldotna	29
Employment – State of Alaska Department of Labor & Workforce Development	38
Demographics – U.S. Census Bureau, AK Dept of Labor & Workforce Dev.	40
Homer	
Sales – KPB Finance Department	47
Construction – City of Homer	55
Kenai	
Sales – KPB Finance Department	61
Construction – City of Kenai	69
Seldovia	
Sales – KPB Finance Department	75
Construction – City of Seldovia	83
Seward	
Sales – KPB Finance Department	89
Construction – City of Seward	97
Soldotna	
Sales – KPB Finance Department	103
Construction – City of Soldotna	111
Other	
Sales – KPB Finance Department	117
Directory of Local Officials	125

Data Sources are listed in each subsection.

Introduction

Kenai Peninsula Borough (KPB) staff develops quarterly reports presenting regional economic data for use by businesses, agencies, and other entities to aid in planning and management decisions.

The publication is divided into eight sections: Kenai Peninsula Borough, Homer, Kenai, Seldovia, Seward, Soldotna, Other KPB and a Local Officials Directory.

To provide unity within the document, certain conventions are applied:

- In the real estate section, the following abbreviations apply:
 - RN - Residential New
 - RA - Residential Alteration/Addition
 - CN - Commercial New
 - CA - Commercial Alteration/Addition

Public projects are included in the commercial categories while permits issued for signs are not presented in this publication.

Due to concerns of releasing proprietary sales information, lines of business (LOB) have been grouped into categories. LOB category abbreviations, and LOB's included in each category are listed below.

PROD	Resource Production	Agriculture, Forestry, Fishing and Hunting Mining - (Includes oil and gas exploration, gravel) Timbering
MFG	Manufacturing	Manufacturing - (Includes oil and gas manufacturing, fish processing)
CONST	Construction	Construction
SALES	Sales	Restaurant, Bar Retail
PROP	Rentals	Rental Commercial Property Rental Residential Property Rental Personal Property Rental Non-residential Properties Trailer Court
TOUR	Tourism	Arts, Entertainment, Recreation Guiding Land Guiding Water Accommodation
SERV	Services	Administration, Support, Waste Management, Remediation Educational Services Finance and Insurance Information Other Services Remediation Services Cable Telecommunications
PROF	Professional	Health and Social Services Management of Companies, Enterprises Professional, Scientific, Technical
UTIL	Utilities	Utilities
TRAN	Transport/ Warehouse	Transportation and Warehousing – (Includes Pipelines)
WHSL	Wholesale	Wholesale
GOV	Public Administration	Public Administration - (Includes Native Organizations)

- Information sources for each section of the publication are listed in the index.
- General information applicable to all sections is provided in the KPB section.
- Percentages of parts may not total 100%, due to rounding.

Information presented assists in decision-making by providing economic and demographic information in graphic, table and text form. Data is used by local and state government officials; local, state and federal agencies; businesses within the KPB and elsewhere; and private citizens.

Data is received from various sources and is subject to change as updates, revisions and corrections are received. The KPB makes no claims to accuracy or completeness of information provided. Only summary information is published. For further detail, contact Jeanne Camp or Michelle Blackwell, Kenai Peninsula Borough, 907-714-2336, or the data source listed in the index.

Reports are available electronically at <http://www.borough.kenai.ak.us>. Select the Economic Development link in the left hand column, then Publications. Select the publication of interest.

Kenai Peninsula Borough staff appreciates contributions from the entities listed below, each of which provided data for this publication.

Alaska Department of Labor and Workforce Development (AK DOLWD)

City of Homer

City of Kenai

City of Seldovia

City of Seward

City of Soldotna

KPB Finance Department, Sales Tax Division

The writer wishes to thank those persons who gave of their time to review this document, finding errors and making suggestions that result in a more professional and accurate document. Those individuals include Jane Stein, former Soldotna City Council Member and Sylvia Vinson, KPB Planning Department staff.

Executive Summary

Briefly. Fourth quarter 2008 gross sales increased 10.4% when compared to fourth quarter 2007 while annual sales grew by 12.6%. Quarterly taxable sales gained 4.2% while the annual growth was 6.2%. This is remarkable growth in the face of the economic downturn across the country and around the globe. Total value of fourth quarter construction permits was 77.8% less than a year ago, but the 2007 fourth quarter value was 224.2% greater than the previous year. Fourth quarter 2008 activity was near the average level. Annual permit values were 28.9% above those of 2007, certainly influenced by permitting of both Lowe's and WalMart in Kenai. The quarterly volume of permits dropped from 56 to 41 but was well above the 33 issued during 2006. For the year, volume dropped 9.0% from 334 permits to 304. With regard to unemployment estimates, both the labor force and the number of employed workers was greater than one year ago, but the labor force had increased at a greater rate than employment, resulting in a higher unemployment rate. Unemployment detail is not an actual count, but rather an estimate based upon survey responses and calculations used in the standardized model.

Sales. Fourth quarter 2008 gross sales of \$998,115,145 gained 10.4% or \$94,237,365 over fourth quarter 2007 when the total reached \$903,877,780. Four of the five cities that impose a sales tax had increased gross sales when compared to one year earlier. The large Other KPB region, the area outside the cities, also had increased total gross sales. Annual sales followed the same pattern. Taxable sales continued to rise, reaching \$211,902,600, gaining \$8,614,311 over the 2007 fourth quarter total \$203,288,289. Each jurisdiction experienced increased taxable sales during both quarterly and annual permitting.

Construction. Construction permit values for fourth quarter 2008 were 77.8% less than during fourth quarter 2007. Total permitting value for the 2007 fourth quarter was \$22,494,245 versus \$4,986,021 for the fourth quarter of 2008. Volume of permits issued decreased from 56 during fourth quarter of 2007 to 41 permits issued during fourth quarter 2008, a 26.8% decline. For the year, total assessed value of permits gained 28.9% to \$92,362,635 although volume of permits issued dropped by 9.0% to 304.

Unemployment. Four sets of unemployment data are estimated each month based upon survey data which is entered into a federal standardized model. Comparing fourth quarter 2008 unemployment statistics with those of fourth quarter 2007 we find the following. The 2008 fourth quarter average monthly labor force gained 622 persons over fourth quarter 2007. Average monthly employment for the period was up by 233 jobs over the same period of 2007. Unemployment increased by 389 persons when compared to fourth quarter 2007. The corresponding quarterly average monthly unemployment rate increased to 9.1% from the 2007 fourth quarter average of 7.8%, a 1.3% increase.

Executive Summary

Musings. A recession is an extended decline in general business activity. The National Bureau of Economic Research defines a recession as three consecutive quarters of falling real gross domestic product. The U.S. 2nd quarter 2008 GDP rose 2.8% with strength in exports, personal consumption and government spending. Imports decreased. Third quarter marked the beginnings of stagnation and decline as the GDP dropped 0.5%. By the end of 4th quarter 2008, preliminary reports indicate the GDP decreased 6.2% with decreased exports, decreased imports and decreased personal consumption. Government spending continued to increase. The U.S. Bureau of Economic Affairs website <http://www.bea.gov/newsreleases/national/gdp/gdpnewsrelease.htm> lists periodic news releases regarding national economic statistics.

While the world adjusts to weakened economic activity – mortgage defaults, high unemployment, downsizing and layoffs, decreased market values, concerns of increased fuel costs and all the other factors of a recessionary period – effects in the KPB are less noticeable than in many areas of the country. Per the Alaska Department of Labor, Alaska's foreclosure rate is at a 15-year high but is lower than most of the nation. The foreclosure rate in the Kenai recording district, which includes Soldotna actually decreased from 2007 to 2008.

Although Agrium has ceased operations, a concern for many, employment across the KPB has increased. Data for 2008 indicating where the jobs have grown will not be available until late summer 2009. Yes, the unemployment rate has increased but that is due to a labor force that has grown faster than employment.

Taxable sales have continued to increase annually, a trend not broken since the KPB began preparing economic reports. Construction project values and volume have their normal ups and downs, but 2008 did not see a significant decrease in activity when compared to long term trends.

Indications are that local businesses may have delayed certain developmental projects but hope to reactivate plans as the economy completes its adjustment phase and talk of recession and depression fade.

The governor continues work to develop a 48" natural gas pipeline from the North Slope to the lower 48 states while Enstar studies a 24" line from northern Alaska to the Cook Inlet basin. A feasible Enstar project would have an industrial user in our region, and there has been some discussion regarding reopening the Agrium plant if additional natural gas supplies become available. The Pebble Mine is still under consideration as well. Any of these projects will strengthen our economy.

The economic situation has most noticeably affected the KPB tourism industry, resulting in fewer visitors and significant decreases in both gross and taxable sales for industry participants.

Executive Summary

SALES

Sales data presented in this publication is accurate as of March 3, 2009. Sales are categorized according to the NAICS LOB selected by each establishment as license applications were completed. See page 13 for the listing.

A change in sales reporting requirements became effective as of April 2004 that allows businesses with less than \$6,000 in annual taxable sales, and meeting other reporting requirements, to prepare a sales report on the fourth quarter reporting timeline, thereby reporting on an annual rather than a quarterly basis. This skews quarterly gross sales data as fewer sales are reported during first, second and third quarter, but increased sales are reported during fourth quarter when annual sales reports are due. Additional reporting requirements have also been implemented which require businesses to report nontaxable sales and to indicate which exemption allows the exclusions.

Quarterly Sales

KPB gross sales increased 10.4% to \$998,115,145 for the quarter, \$94,237,365 more than during fourth quarter 2007. Nine of twelve LOB's marked gains while three had decreasing sales. Taxable sales gained 4.2% to reach \$211,902,600, surpassing 2007 fourth quarter sales by \$8,614,311 as six of twelve LOB's experienced increased sales.

Gross by Line of Business. Nine LOB's increased quarterly sales as sale of manufactured goods rose 104.8%, increasing from \$18,827,857 during fourth quarter 2007 to \$38,554,005 during the same quarter 2008, although 2007 sales were unusually low. Utility sales gained 25.3% to reach \$40,448,331, well above 2007 fourth quarter total, \$32,282,685. Transportation & warehousing sales increased from \$42,583,073 to \$52,304,123, a 22.8% gain. Retail sales gained 15.0% as sales increased by \$24,844,381 to \$190,541,495 for the quarter. Sale of wholesale goods rose 10.5% to \$368,807,009 gaining \$34,974,594 over the 2007 total, \$333,832,415. With single-digit gains, service sales rose 8.1% to reach \$52,569,574 while resource production sales of \$99,005,432 were 6.5% greater than fourth quarter one year ago. Sale of professional services increased 5.1% to \$23,394,761 and sales by government agencies were 3.1% greater than one year ago with \$4,259,058 in sales.

Construction sales declined 3.6% to \$92,781,546 while sales involving property lost 4.2% to total \$25,201,147. Lastly, tourism saw a significant drop in sales, declining 49.2% to \$10,248,664, down \$9,910,462 from the 2007 fourth quarter total of \$20,159,126. (See page 15 for detail.)

Taxable by Line of Business. Six of twelve LOB's experienced increased sales when comparing fourth quarter 2007 with 2008 while KPB total taxable sales increased 4.2% to \$211,902,600 over 2007 quarterly sales, \$203,288,289.

Executive Summary

The largest percentage gain, 22.4%, occurred as utility sales totaled \$16,449,636. Resource production sales increased 19.8% to \$1,720,436. Taxable retail sales increased 13.7% to \$119,003,130. Sale of services followed with a 9.7% gain for a \$25,594,681 total. Sales in government grew by 2.5% to reach \$3,634,039 while transportation & warehousing sales increased 1.1% to total \$795,326.

Declining taxable sales occurred in the other six LOB's. Taxable sales involving property were down 0.4% to \$9,601,160 while sales of professional services decreased 0.6% to \$3,993,702. Construction sales of \$3,239,278 were 2.1% below those of one year ago while sale of wholesale goods was down 6.4% to \$19,181,999. Manufacturing sales dropped 18.4% to \$1,355,588. Finally, tourism businesses saw sales decrease by 56.8% to \$7,333,625, down from \$16,964,907 during fourth quarter 2007. (See page 16 for detail.)

Gross by Area. KPB gross sales increased 10.4% when comparing fourth quarter 2007 sales with those of fourth quarter 2008, with sales of \$998,115,145. Five of six jurisdictions imposing a sales tax saw increased sales. Kachemak City does not impose a sales tax so there is no record of sales in that city. The large Other KPB area had sales totaling \$582,408,021 for the quarter, a 14.4% gain. Seward followed closely with a 12.0% increase to quarterly sales of \$38,808,545. Homer sales grew by 8.7% to total \$88,035,825 while Kenai sales of \$169,795,535 were 6.8% greater than one year ago. Lastly, Soldotna sales of \$116,991,515 gained 0.1% over the 2007 fourth quarter total of \$116,869,811.

Seldovia quarterly sales dropped 38.1% to \$2,075,704. (See detail on page 17.)

Taxable by Area. Fourth quarter 2008 taxable sales rose 4.2% as all six jurisdictions experienced increased sales. Other KPB had the largest percentage gain, 9.2%, with sales of \$63,144,175. Kenai sales increased 3.3% to reach \$42,457,879, gaining \$1,347,518 over the fourth quarter 2007 total, \$41,110,361. Seward sales increased 3.1% to \$13,080,362 from \$12,683,490. Sales in Seldovia totaled \$857,233, gaining 3.0% over the 2007 fourth quarter total. Soldotna sales were 2.5% above 2007 with sales totaling \$59,587,854, gaining \$1,474,556 over 2007 sales of \$58,113,298. Lastly, Homer saw sales increasing 0.2% for a total of \$32,775,097, just \$63,000 over one year ago. (See detail on page 18.)

Annual Sales

KPB 2008 gross sales increased 12.6% to \$3,159,657,109 from the 2007 total of \$2,805,925,989, gaining \$353,731,120. This is the first time annual gross sales have exceeded the \$3 billion mark. Sales during 2006 reached \$2,701,313,985.

Taxable sales increased 6.2% from 2007 to 2008 with sales of \$1,026,854,330, the first annual total to pass the \$1 billion mark.

Executive Summary

Gross by Line of Business. Ten of twelve LOB's experienced increased sales when comparing 2008 to 2007 as total sales reached \$3,159,657,109, a 12.6% gain, \$353,731,120 over 2007 when sales reached \$2,805,925,989. Sales in manufacturing reached \$262,581,508, a 33.6% or \$66,065,370 increase. Transportation & warehousing sales totaled \$219,186,646, increasing 32.8% or \$54,116,143 over the \$165,070,503 in 2007 sales. Sale of wholesale goods gained \$95,519,385 to reach \$629,233,693, a 17.9% increase while retail sales had an \$115,635,158 gain to \$809,475,081, a 16.7% increase over 2007 sales.

With lesser percentage growth, service sales increased \$25,614,900, a 13.0% gain, to \$223,400,639 and utility sales had a 12.7% increase with sales totaling \$136,700,502, a \$15,380,652 gain over 2007. Resource production sales were up 10.9% to \$220,624,624, gaining \$21,771,667 in sales. Sale of professional services were up \$6,695,787 to \$75,773,077, a 9.7% increase. Sales by government agencies gained 5.8% to total \$17,314,932 while sales involving property increased 5.0%, or \$4,751,832 to \$99,601,202.

Construction sales decreased 0.3% for 2008 with sales of \$310,212,011, down \$865,112 from the 2007 total, \$311,077,123. Tourism sales of \$155,553,194 were 25.0% below 2007 sales of \$207,455,951. (See detail on page 19.)

Taxable by Line of Business. Taxable sales gained 6.2% during over those of 2007 as ten of twelve LOB's saw increasing sales. Total sales of \$1,026,854,330 were \$59,663,343 above 2007 when KPB sales totaled \$967,190,987. The 2008 annual total marked the first annual total over the \$1 billion mark.

Transportation & warehousing sales rose 25.5% or \$739,892 to \$3,644,236, the largest percentage increase. Retail sales of \$538,927,936 were 19.0% greater than 2007 when sales totaled \$452,696,833 while resource production sales gained 12.7% or \$754,406 to reach \$6,694,810. Service sales of \$106,613,261 were 10.8% above sales one year earlier when sales totaled \$96,224,461.

With single-digit gains, utility sales rose 6.6% to reach \$56,985,954 while sales involving property rose 6.3% to \$41,708,890. Taxable sales of wholesale goods grew by 5.0% to \$86,329,055. Construction sales and sale of professional services each gained 3.2% with \$12,610,340 and \$17,695,101, respectively. Government sales rose 3.1% to \$14,631,227.

With decreases, manufacturing sales dropped 15.3% to \$8,880,367 and tourism sales of \$132,133,153 were 26.8% less than during 2007. (Detail on page 20.)

Gross by Area. KPB gross sales increased in five of six jurisdictions as annual sales gained 12.6% from the 2007 level to the 2008 total when sales were \$3,159,657,109, up from \$2,805,925,989, the first year in which sales exceeded the \$3 billion mark. Kenai 2008 sales, \$607,676,556, were 16.7% greater as

Executive Summary

construction sales gained 62.3%. Sales outside the cities increased 14.1% to \$1,480,554,810, as service sales increased by 33.3%. Seward sales reached \$214,574,775, gaining 9.9% or \$19,326,521. Soldotna gained 8.4% and Homer sales were up 8.3% with sales of \$465,405,888 and \$382,914,299, respectively.

With declining sales, Seldovia sales decreased 10.2% to \$8,530,781, dropping by \$965,034. (See detail on page 22.)

Taxable by Area. Taxable sales increased in each jurisdiction when comparing 2008 with 2007 as annual sales increased 6.2% to \$1,026,854,330. The greatest percentage growth came in Seldovia, 15.9%, where sales reached \$5,004,876, gaining \$687,148 over the 2007 total, \$4,317,728. With 8.2% growth Other KPB sales gained \$23,304,639 to reach \$306,848,624. Soldotna 2008 sales of \$17,599,562 were 7.2% greater than 2007 when sales totaled \$243,495,221. With 5.3% growth, Kenai sales reached \$175,891,484, gaining \$8,814,106 over 2007 sales of \$167,077,378. Homer's total, \$173,010,794, was 3.9% above the 2007 total, gaining \$6,509,845. Lastly, Seward's annual sales were 2.7% above those of 2007. The 2008 total reached \$105,003,769, up \$2,748,043 over the 2007 total, \$102,255,726. (See detail on page 23.)

CONSTRUCTION ACTIVITY

Quarterly Permitting

Construction permit values in the borough declined 77.8% from fourth quarter 2007 to 2008. Quarterly values totaled \$4,986,021, dropping from \$22,494,245 of the fourth quarter 2007. This is the second lowest fourth quarter permit value since 2001. Volume of permits issued declined by 15 as 41 permits were issued in 2008 compared to 56 during 2007.

By Area, Value. Homer issued the highest total value of construction permits during fourth quarter 2008 with a total of \$2,884,000, up 77.8% from fourth quarter 2007. Kenai followed Homer in total value with \$1,465,875 in permits issued, gaining 233.4% over one year ago. Seward's total permit value dropped from \$18,139,500 to \$362,000, 98.0%, but during 2007 Seward permitted a long term care facility with an \$18,000,000 value. Soldotna values decreased to a total value of \$264,146 from \$2,292,045 a year ago, but during 2006 issued permits with a total value of \$632,882. (See detail on page 28.)

By Area, Volume. There were 41 construction permits issued across the KPB when comparing 2008 with 2007 fourth quarter, 15 fewer. Kenai issued 15, up from 14 permits a year ago. Seldovia was stable, issuing one permit each of the past two fourth quarters. Seward issued nine permits each of the past two fourth quarters. Homer activity decreased from 16 to 11 permits for the period while Soldotna activity dropped from 16 to five. (See detail on page 28.)

Executive Summary

By Type, Value. KPB fourth quarter 2008 total permit value of \$4,986,021 was 77.8% below 2007 as new residential construction projects totaled \$1,628,875, 74.6% higher than 2007 activity. Commercial alterations/additions added \$1,584,000, gaining 117.1%. New commercial projects added \$921,146 in assessed value and residential alteration/addition permitting had a total value of \$852,000 for the quarter. (See detail on page 29.)

By Type, Volume. Forty-one permits were issued during fourth quarter, down from 56 during fourth quarter 2007. New residential permitting increased from 7 to 10 while alteration/additions decreased from 26 to 14. Two fewer commercial alteration/additions permits were issued, 13, while four new commercial projects were approved, down from eight a year ago. (See detail on page 29.)

Annual Permitting

2008 construction permit values totaled \$92,362,635, a new record high as Kenai permitted construction of both Lowe's and WalMart facilities. Permitting activity during four of the past five years has resulted in values well above the norm. The 2007 total assessed permit value was \$71,656,850 while the 2006 total was \$80,230,660. Permits are required for projects within KPB cities but building permits are not required for areas within the KPB jurisdiction.

Issuance of 304 construction permits marked a decline from the 334 issued during 2007, the lowest volume since 2000 when 303 permits were issued. The 2005 record high volume was 338 permits.

By Area, Value. KPB's 2008 total permitted value reached \$92,362,635, gaining 28.9% over the 2007 total, \$71,656,850. Kenai, with a 2008 total permit value of \$46,486,375, accounted for 50.3% of KPB's annual total, gaining 107.5% over the city's 2007 total of \$22,398,000. Two new commercial projects were permitted, Lowe's and WalMart. Homer saw a 64.8% gain in total permit value to \$23,168,200 from \$14,056,202 during 2007 with strength in commercial permitting. Soldotna's total value, \$19,493,181, was 41.6% greater than a year earlier with strength in new commercial permitting. Seldovia's total grew from \$343,800 to \$382,500 for the year.

Seward's total, \$2,832,379 dropped 86.6% from the 2007 total when a large long-term-care facility was permitted. (See detail on page 30.)

By Area, Volume. As 304 building permits were issued, only Soldotna and Kenai increased activity. Soldotna permitting grew from 80 permits during 2007 to 91 during 2008. Kenai issued 114 permits, two greater than one year ago.

Seward permitting decreased from 37 to 30 during 2008 while Homer issued 62, 25 less than a year ago when 87 permits were issued. Lastly, Seldovia issued seven permits, down from 18 issued during 2007. (See detail on page 32.)

Executive Summary

By Type, Value. New commercial permitting provided 66.1% of 2008 annual permit value with \$61,078,166 of the \$92,362,635 KPB total. New commercial permitting was 79.9% greater than 2007 influenced by Lowe's and WalMart permits in Kenai. New residential projects added \$21,563,338, down 4.6% from \$22,612,367 during 2007. Commercial alteration/addition permitting added \$6,992,543, down 36.4% from 2007, while residential alteration/addition activity added \$2,728,588, down 33.6% from a year earlier. (See detail on page 31.)

By Type, Volume. Construction permit volume lost 9.0% during 2008, with decreased activity in three of four reporting categories. One hundred five permits were issued for residential alteration/addition projects, down from 119 one year ago. There were 93 new homes permitted within KPB cities, down from 110 during 2007. New commercial permitting dropped from 37 during 2007 to 27 during 2008. Commercial alteration/addition permitting increased from 68 to 79 for the year, a 16.2% increase over 2007. (See detail on page 31.)

UNEMPLOYMENT

Monthly unemployment data are received from the AK DOL&WD. Data are developed from a survey of residents across the region with survey results input into a nationwide model. The detail is not an actual count, but rather an estimate based upon survey responses and calculations used in the standardized model.

The October 2008 estimate of KPB's labor force was 25,626 persons, up by 656 persons from 24,970 during October 2007. The November total of 25,470 was up from 24,923 a year ago. KPB's December 2008 labor force estimate was 25,689 persons, up by 663 persons from 25,026 during December 2007. The annual monthly average labor force, 26,240, was 501 persons greater than the 2007 annual monthly average.

October 2008 saw 2,093 unemployed KPB residents, up by 416 over 1,677 one year ago. November unemployment increased to 2,297, gaining 368 over one year earlier when 1,929 persons were unemployed. The December 2008 count increased to 2,589, a gain of 383 over December 2008. The 2008 annual monthly average unemployment, 2,412, was 429 persons more than the 2008 annual monthly average when 1,982 persons were unemployed.

KPB's October 2008 unemployment rate of 8.2% was up from 6.7% during October 2007. The rate increased to 9.0% during November, greater than the November 2007 rate of 7.7%. Moving into December 2008 the rate was 10.1%, up from 8.8% a year earlier. The annual monthly average unemployment rate during 2008 was 9.5%, compared to a 7.8% annual monthly average for the same period of 2007.

Executive Summary

The October 2008 employment estimate, 23,533, was up from 23,293 during October 2007, a gain of 240 employed persons. November employment was up to 23,173 from 22,994 a year earlier, up by 179 persons. December employment was 23,100, up from 22,820 during 2007, increasing by 280. The annual monthly average employment increased by 259 workers from 23,757 during 2007 to 24,016 for the 2008 annual monthly average. (See detail on pages 36 and 37.)

POPULATION

Population estimates for 2007 show the KPB population at 52,386 persons, a 2.0% increase for the year. Since Census 2000, KPB's natural increase (births minus deaths) has resulted in a gain of 2,695 persons. Other changes are due to in or out migration.

CDP's and cities with the greatest estimated change from 2006 to 2007 include Kalifornsky, with a gain of 215 persons, Soldotna gaining 175 and Nikiski added 166. Kenai gained 107 individuals. Sterling and Seldovia gained 87 and 66, respectfully. Kasilof grew by 49 persons, Homer gained 48, and Diamond Ridge added 43 to their totals. Fritz Creek and Seward each added 34 persons while Ridgeway gained 26 and Bear Creek and Happy Valley each added 23. Funny River gained 18 persons, Anchor Point grew by 11, and Clam Gulch grew by 10 persons. Both Lowell Point and Kachemak City gained nine persons, while Fox River and Hope each added four. Cohoe added three persons while Nikolaevsk had zero change.

With decreasing population, Salamatof was down by 28 individuals while Tyonek had an 18 person decrease. The Nanwalek estimate was down by 11 while Crown Point saw a seven person drop. Ninilchik lost six persons while the Cooper Landing and Halibut Cove estimates were down by four. Beluga, Port Graham and Sunrise each saw a two person decrease. The number of persons living outside the cities and cdp's dropped from 164 to 124. Finally, Primrose and Moose Pass lost 1 and 3 residents, respectfully.

Since Census 2000, Homer has increased by 39.4% to 5,502 but that gain includes its 2002 annexation. Kachemak City increased by 8.4% to a total of 467 persons. Kenai gained 0.4% to 6,971 residents. Seldovia City decreased 0.7% to 284 and Seward lost 6.0%, to 2,661 persons. Soldotna's population increased 5.9% to 3,982. (See page 39 for detail.)

Just in, the 2008 preliminary population estimate for the KPB is 53,017. If confirmed, this would mark 1.2% annual increase and a 6.7% increase since Census 2000.

KPB Sales

KPB sales information includes detail from Homer, Kenai, Seldovia, Seward, Soldotna and "Other" - which indicates KPB regions outside boundaries of the five incorporated cities. It also includes Kachemak City, which does not impose a sales tax. The 3% KPB sales tax is included in the city rates listed below. The balance is imposed by each city. KPB sales tax assessments increased from 2% to 3%, effective January 1, 2008. Proceeds continue to be dedicated to the KPB school district. Sales are reported by Line of Business (LOB) based upon the LOB listed on the establishment's business license application.

Sales data presented is accurate as of March 3, 2009.

7.5%	7.0%	6.0%	5.0%	3.0%
Homer	Seward	Kenai	Seldovia	Other
Seldovia (April - September)		Soldotna	(October - March)	

Table 1.1

Gross and taxable sales data are received quarterly through Sales Tax Returns from KPB businesses. Exempt sales within the KPB jurisdiction include the following:

- Sales outside the borough;
- Sales to tax exempt organizations; and
- Sales for resale;
- Sales in excess of \$500.
- Sales to government agencies;

Due to concerns of releasing proprietary information, similar LOB's have been grouped into categories. LOB abbreviations and LOB's included in each category are listed below.

PROD	Resource Production	Agriculture, Forestry, Fishing and Hunting Mining - (Includes oil and gas exploration, gravel) Timbering
MFG	Manufacturing	Manufacturing - (Includes oil and gas manufacturing, fish processing)
CONST	Construction	Construction
SALES	Sales	Restaurant, Bar Retail
PROP	Rentals	Rental Commercial Property Rental Residential Property Rental Personal Property Rental Non-residential Properties Trailer Court
TOUR	Tourism	Arts, Entertainment, Recreation Guiding Land Guiding Water Accommodation
SERV	Services	Administration, Support, Waste Management, Remediation Educational Services Finance and Insurance Remediation Services Telecommunications Information Other Services Cable
PROF	Professional	Health and Social Services Management of Companies, Enterprises Professional, Scientific, Technical
UTIL	Utilities	Utilities
TRAN	Transport/ Warehouse	Transportation and Warehousing - (Includes pipelines)
WHSL	Wholesale	Wholesale
GOV	Public Administration	Public Administration - (Includes Native Organizations)

Table 1.2

KPB Sales

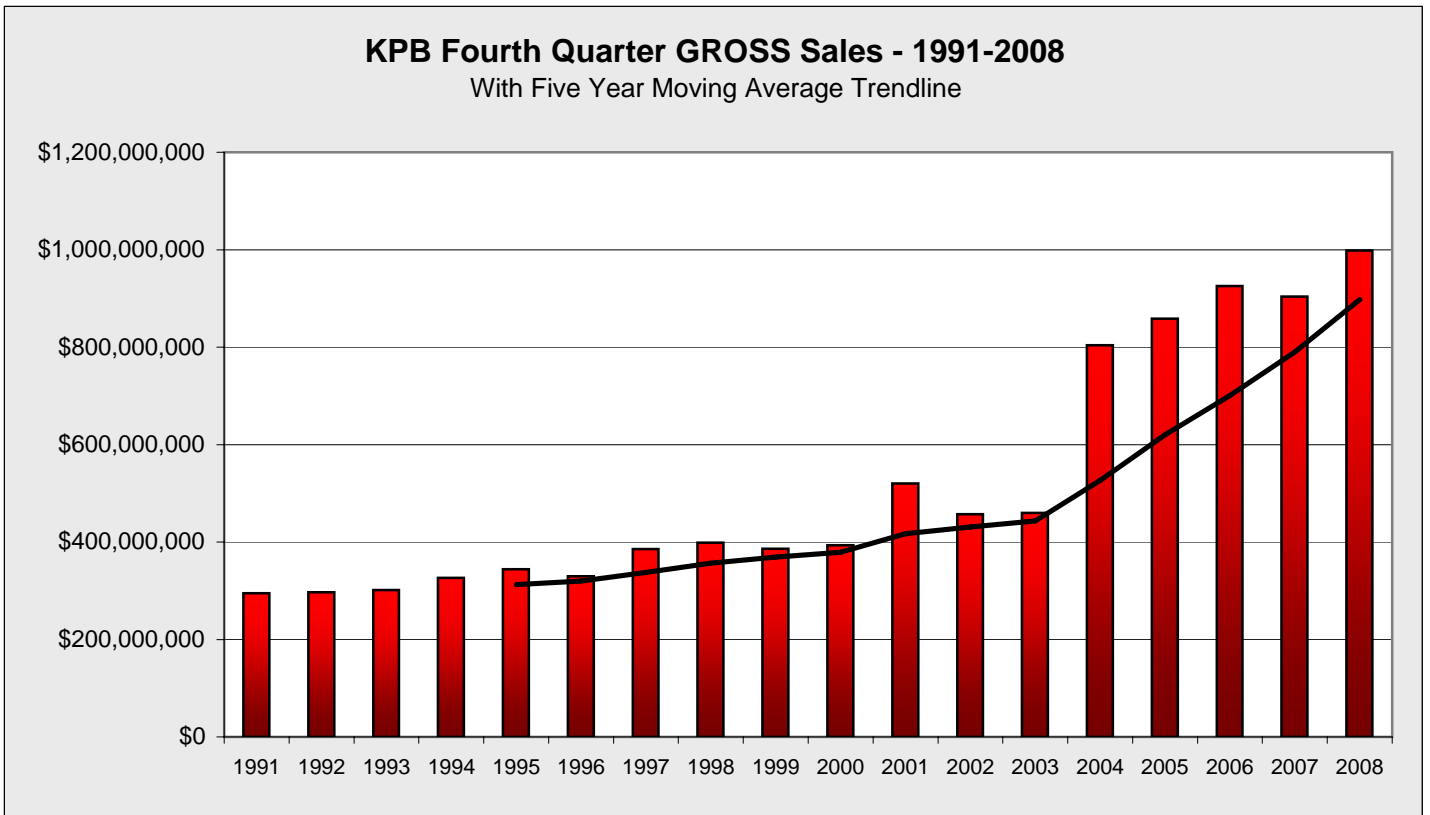

Chart 1.1

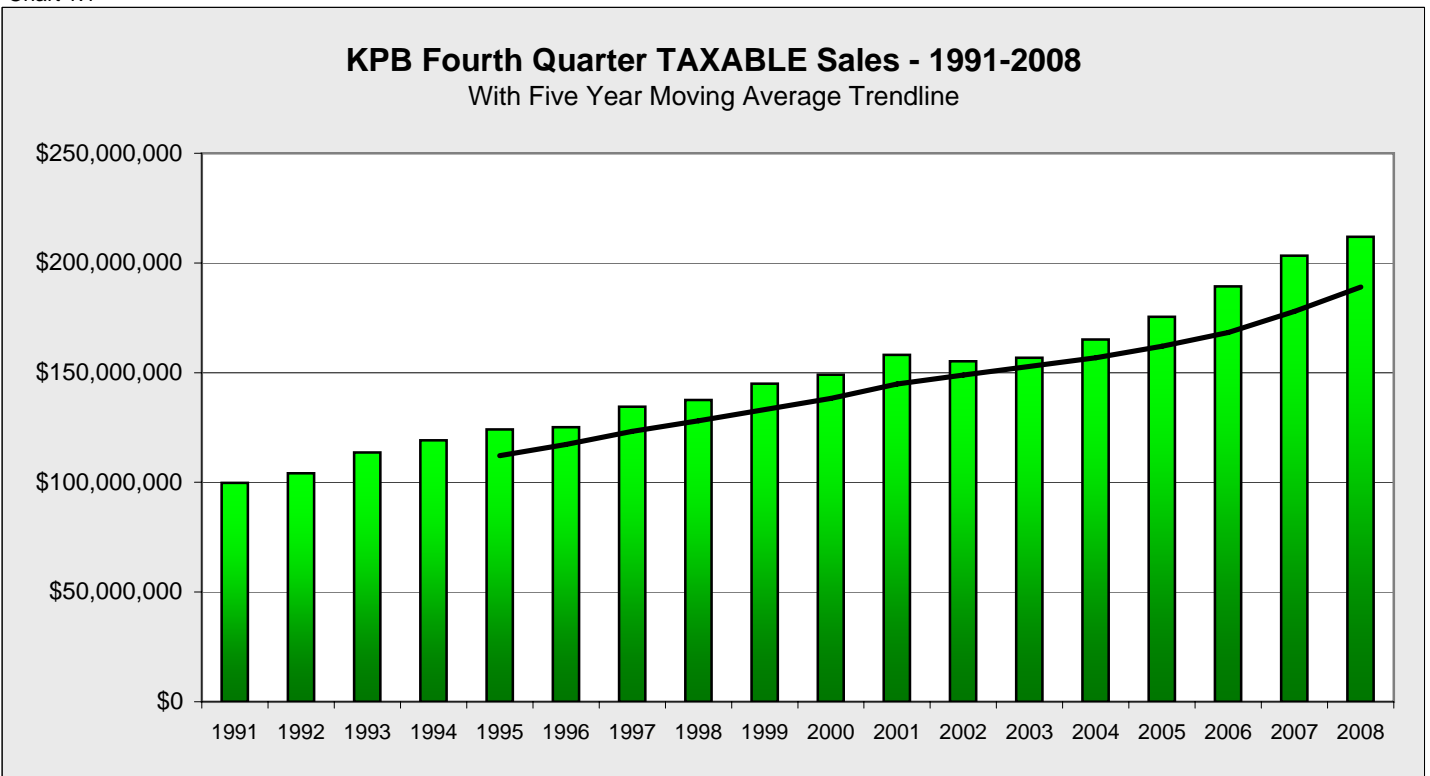

Chart 1.2

KPB Sales

KPB Fourth Quarter GROSS Sales by Line of Business - 2003-2008 - in \$*								
LOB	2003	2004*	2005	2006	2007	2008	Annual Percent Change	Annual Amount Change
PROD	56,778,211	146,775,360	119,998,520	71,810,856	92,929,082	99,005,432	6.5%	6,076,350
SALES	134,229,397	141,408,914	142,751,661	152,333,638	165,697,114	190,541,495	15.0%	24,844,381
CONST	61,903,096	96,265,046	111,275,678	176,274,367	96,225,562	92,781,546	-3.6%	-3,444,016
PROP	22,137,265	23,382,636	23,845,059	22,847,644	26,315,106	25,201,147	-4.2%	-1,113,959
TOUR	17,644,883	19,167,424	19,390,538	20,634,097	20,159,126	10,248,664	-49.2%	-9,910,462
SERV	27,082,514	42,126,508	36,535,164	41,378,709	48,640,981	52,569,574	8.1%	3,928,593
PROF	13,054,595	20,815,253	21,636,681	23,239,897	22,254,358	23,394,761	5.1%	1,140,403
UTIL	20,367,042	22,946,239	26,579,805	34,127,150	32,282,685	40,448,331	25.3%	8,165,646
MFG	34,657,808	33,957,639	42,253,513	34,932,465	18,827,857	38,554,005	104.8%	19,726,148
TRAN	6,836,938	11,938,812	38,142,024	38,080,953	42,583,073	52,304,123	22.8%	9,721,050
WHSL	61,130,736	240,819,994	271,937,317	305,799,784	333,832,415	368,807,009	10.5%	34,974,594
GOV	3,814,224	4,218,909	3,925,279	4,157,113	4,130,421	4,259,058	3.1%	128,637
TOTAL	459,636,709	803,822,734	858,271,239	925,616,673	903,877,780	998,115,145	10.4%	94,237,365
Annual Change		74.9%	6.8%	7.8%	-2.3%	10.4%		

Table 1.3

* - For complete Line of Business (LOB) listing, see page 13.

*Substantial change in total gross sales from 2003 to 2004 is due to changes in reporting requirements.

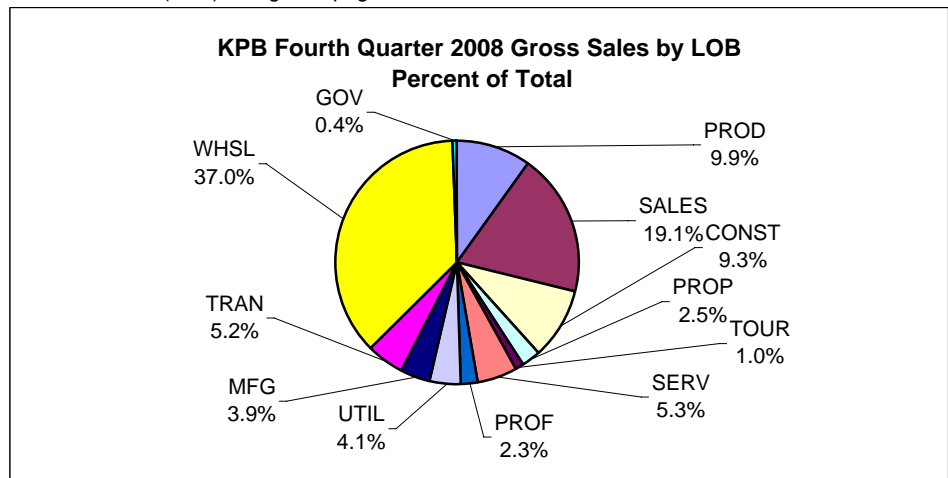

Chart 1.3

Fourth Quarter Gross Sales Five Year Change by LOB				
	2003	2008	Value Change	Percent Change
PROD	56,778,211	99,005,432	42,227,221	74.4%
SALES	134,229,397	190,541,495	56,312,098	42.0%
CONST	61,903,096	92,781,546	30,878,450	49.9%
PROP	22,137,265	25,201,147	3,063,882	13.8%
TOUR	17,644,883	10,248,664	-7,396,219	-41.9%
SERV	27,082,514	52,569,574	25,487,060	94.1%
PROF	13,054,595	23,394,761	10,340,166	79.2%
UTIL	20,367,042	40,448,331	20,081,289	98.6%
MFG	34,657,808	38,554,005	3,896,197	11.2%
TRAN	6,836,938	52,304,123	45,467,185	665.0%
WHSL	61,130,736	368,807,009	307,676,273	503.3%
GOV	3,814,224	4,259,058	444,834	11.7%
TOTAL	459,636,709	998,115,145	538,478,436	117.2%

Table 1.4

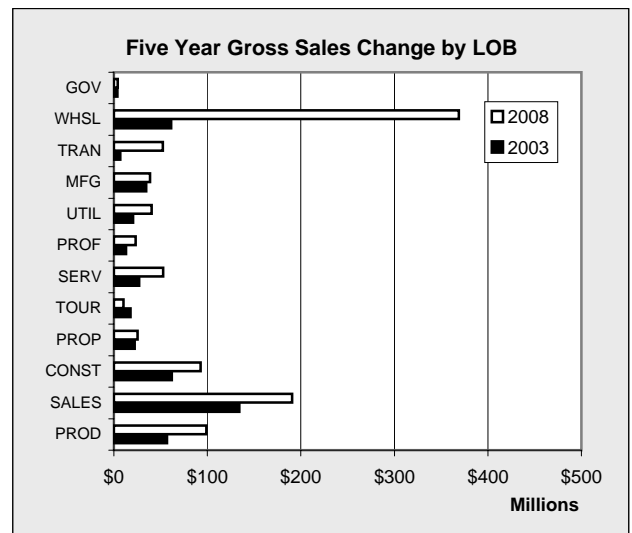

Chart 1.4

KPB Sales

KPB Fourth Quarter TAXABLE Sales by Line of Business - 2003-2008 - in \$*								
LOB	2003	2004	2005	2006	2007	2008	Annual Percent Change	Annual Amount Change
PROD	1,121,743	1,350,937	1,181,996	1,205,699	1,435,890	1,720,436	19.8%	284,546
SALES	84,982,383	85,173,371	89,534,735	96,341,660	104,653,750	119,003,130	13.7%	14,349,380
CONST	2,904,899	2,714,627	2,665,816	3,001,793	3,309,070	3,239,278	-2.1%	-69,792
PROP	7,177,013	7,500,586	7,734,743	8,425,132	9,643,164	9,601,160	-0.4%	-42,004
TOUR	15,894,417	16,092,698	16,660,633	17,527,783	16,964,907	7,333,625	-56.8%	-9,631,282
SERV	17,501,581	18,730,378	19,336,874	20,879,792	23,330,978	25,594,681	9.7%	2,263,703
PROF	3,149,568	3,301,441	3,364,027	3,604,243	4,018,419	3,993,702	-0.6%	-24,717
UTIL	9,122,766	9,802,497	11,116,084	14,111,763	13,438,479	16,449,636	22.4%	3,011,157
MFG	1,143,331	1,144,385	1,828,946	1,703,061	1,661,171	1,355,588	-18.4%	-305,583
TRAN	526,250	402,217	669,691	531,700	786,813	795,326	1.1%	8,513
WHSL	10,412,314	16,001,318	18,330,609	18,735,987	20,501,302	19,181,999	-6.4%	-1,319,303
GOV	2,803,462	2,879,524	3,094,913	3,290,902	3,544,346	3,634,039	2.5%	89,693
TOTAL	156,739,727	165,093,979	175,519,067	189,359,515	203,288,289	211,902,600	4.2%	8,614,311
Annual Change		5.3%	6.3%	7.9%	7.4%	4.2%		

Table 1.5

* - For complete Line of Business (LOB) listing, see page 13.

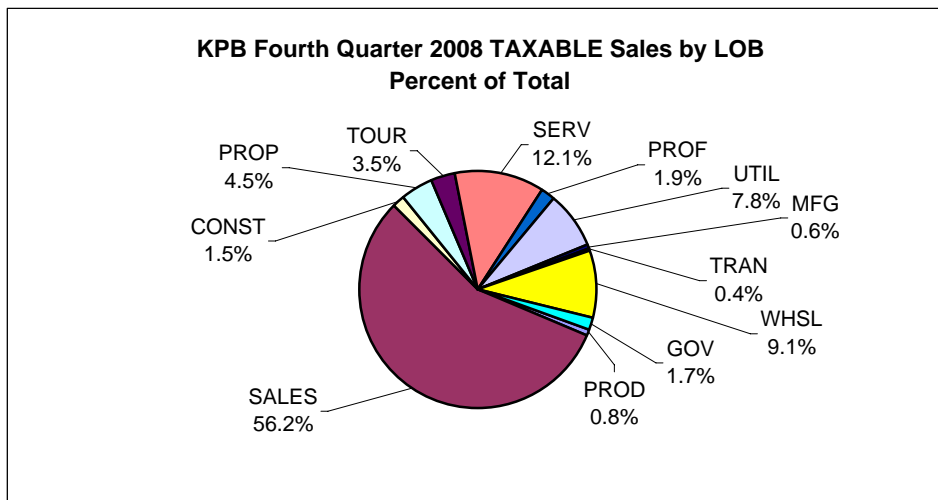

Chart 1.5

Fourth Quarter TAXABLE Sales Five Year Change by LOB				
	2003	2008	Value Change	Percent Change
PROD	1,121,743	1,720,436	598,693	53.4%
SALES	84,982,383	119,003,130	34,020,747	40.0%
CONST	2,904,899	3,239,278	334,379	11.5%
PROP	7,177,013	9,601,160	2,424,147	33.8%
TOUR	15,894,417	7,333,625	-8,560,792	-53.9%
SERV	17,501,581	25,594,681	8,093,100	46.2%
PROF	3,149,568	3,993,702	844,134	26.8%
UTIL	9,122,766	16,449,636	7,326,870	80.3%
MFG	1,143,331	1,355,588	212,257	18.6%
TRAN	526,250	795,326	269,076	51.1%
WHSL	10,412,314	19,181,999	8,769,685	84.2%
GOV	2,803,462	3,634,039	830,577	29.6%
TOTAL	156,739,727	211,902,600	55,162,873	35.2%

Table 1.6

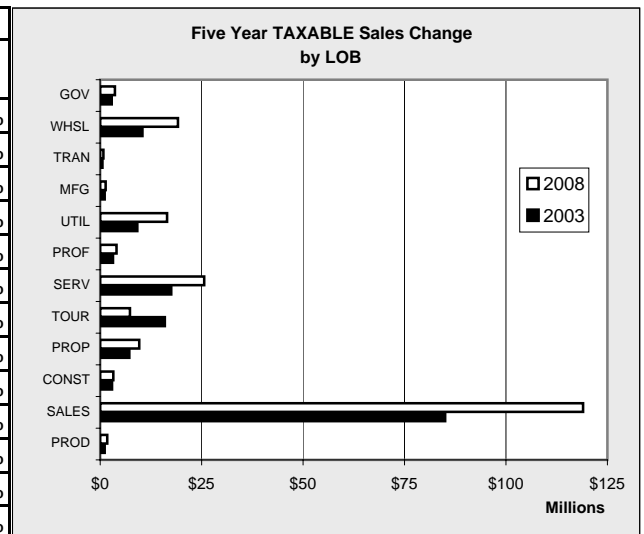

Chart 1.6

KPB Sales

KPB Fourth Quarter GROSS Sales by Area - 2003-2008 - in \$								
	2003	2004*	2005	2006	2007	2008	Annual Percent Change	Annual Amount Change
Homer	60,330,717	72,604,415	70,510,047	92,293,557	81,009,539	88,035,825	8.7%	7,026,286
Kenai	72,488,393	167,961,695	175,254,701	162,841,748	158,922,503	169,795,535	6.8%	10,873,032
Seldovia	1,949,309	3,144,047	1,213,675	1,347,204	3,351,734	2,075,704	-38.1%	-1,276,030
Seward	27,334,414	38,362,822	34,213,681	49,970,454	34,648,367	38,808,545	12.0%	4,160,178
Soldotna	82,155,118	94,822,445	128,504,871	140,217,422	116,869,811	116,991,515	0.1%	121,704
Other	215,378,758	426,927,310	448,574,264	478,946,289	509,075,826	582,408,021	14.4%	73,332,195
Total	459,636,709	803,822,734	858,271,239	925,616,674	903,877,780	998,115,145	10.4%	94,237,365
Annual Change		74.9%	6.8%	7.8%	-2.3%	10.4%		

Table 1.7 *Substantial change in total gross sales from 2003 to 2004 is due to changes in reporting requirements.

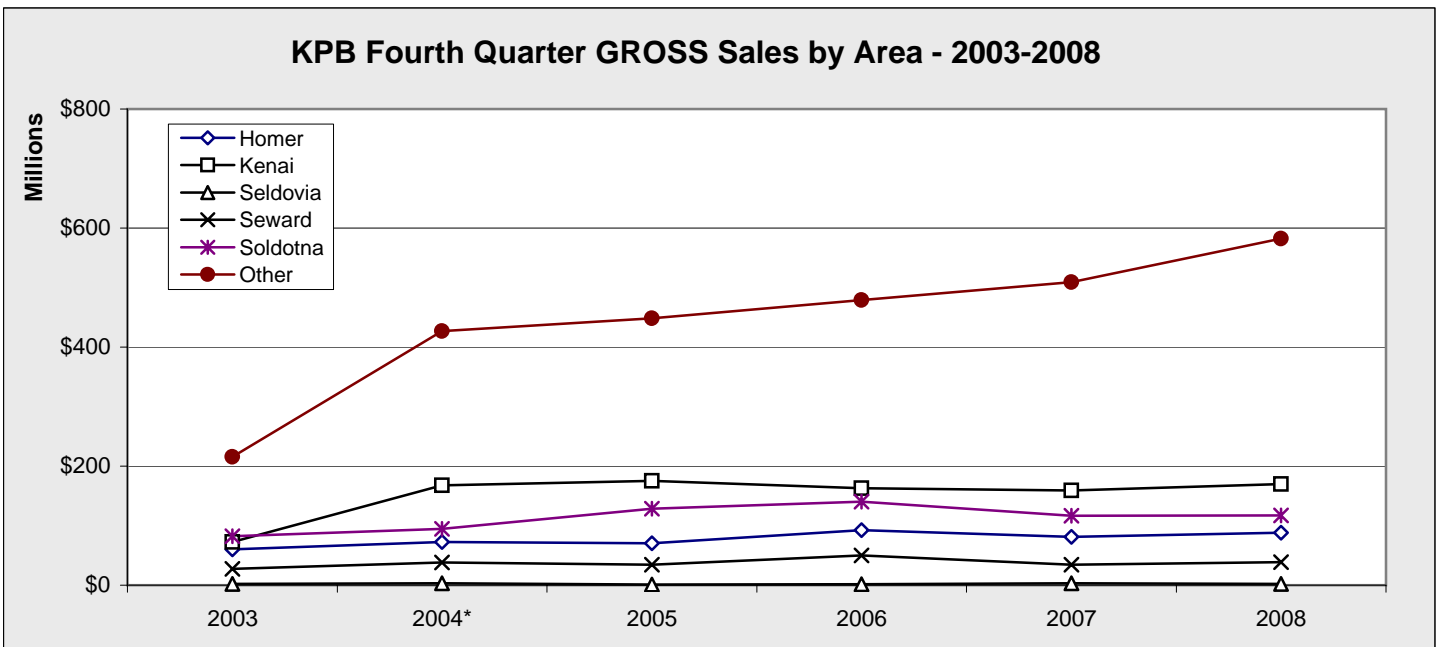

Chart 1.7

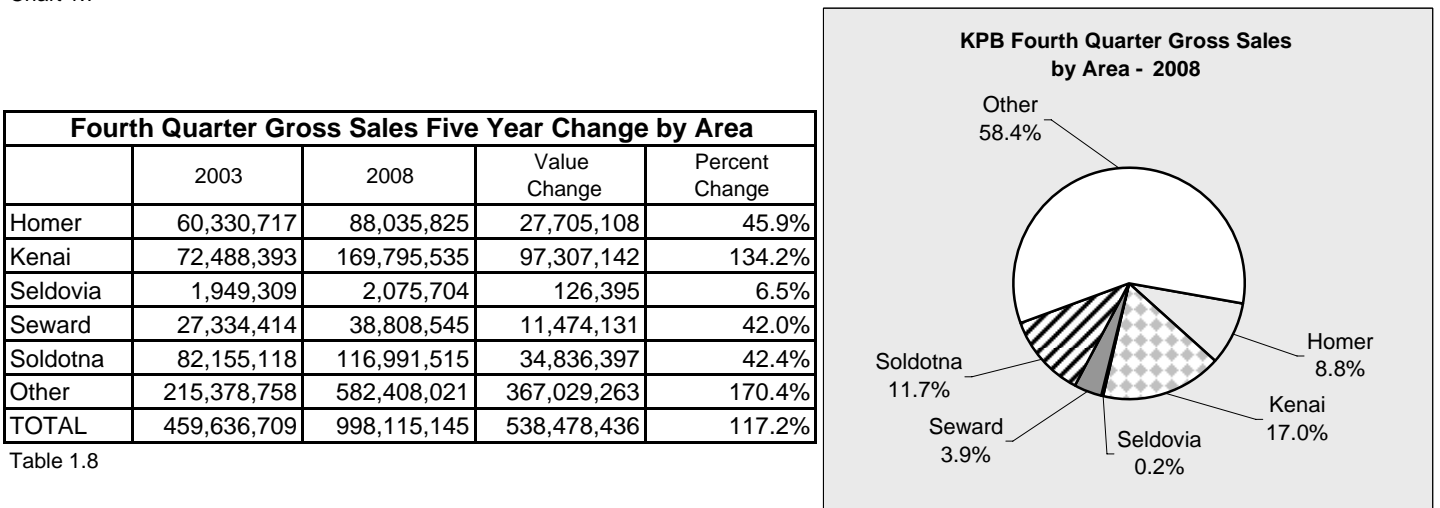

Chart 1.8

KPB Sales

KPB Fourth Quarter TAXABLE Sales by Area - 2003-2008 - in \$								
	2003	2004	2005	2006	2007	2008	Annual Percent Change	Annual Amount Change
Homer	27,107,360	27,499,532	28,577,237	30,462,985	32,712,097	32,775,097	0.2%	63,000
Kenai	29,068,027	33,531,865	35,712,018	37,936,787	41,110,361	42,457,879	3.3%	1,347,518
Seldovia	674,689	697,859	660,146	711,822	832,215	857,233	3.0%	25,018
Seward	10,289,302	10,388,272	11,401,775	11,884,880	12,683,490	13,080,362	3.1%	396,872
Soldotna	46,558,340	47,480,976	50,395,386	54,431,570	58,113,298	59,587,854	2.5%	1,474,556
Other	43,042,009	45,495,475	48,772,505	53,931,471	57,836,828	63,144,175	9.2%	5,307,347
Total	156,739,727	165,093,979	175,519,067	189,359,515	203,288,289	211,902,600	4.2%	8,614,311
Annual Change		5.3%	6.3%	7.9%	7.4%	4.2%		

Table 1.9

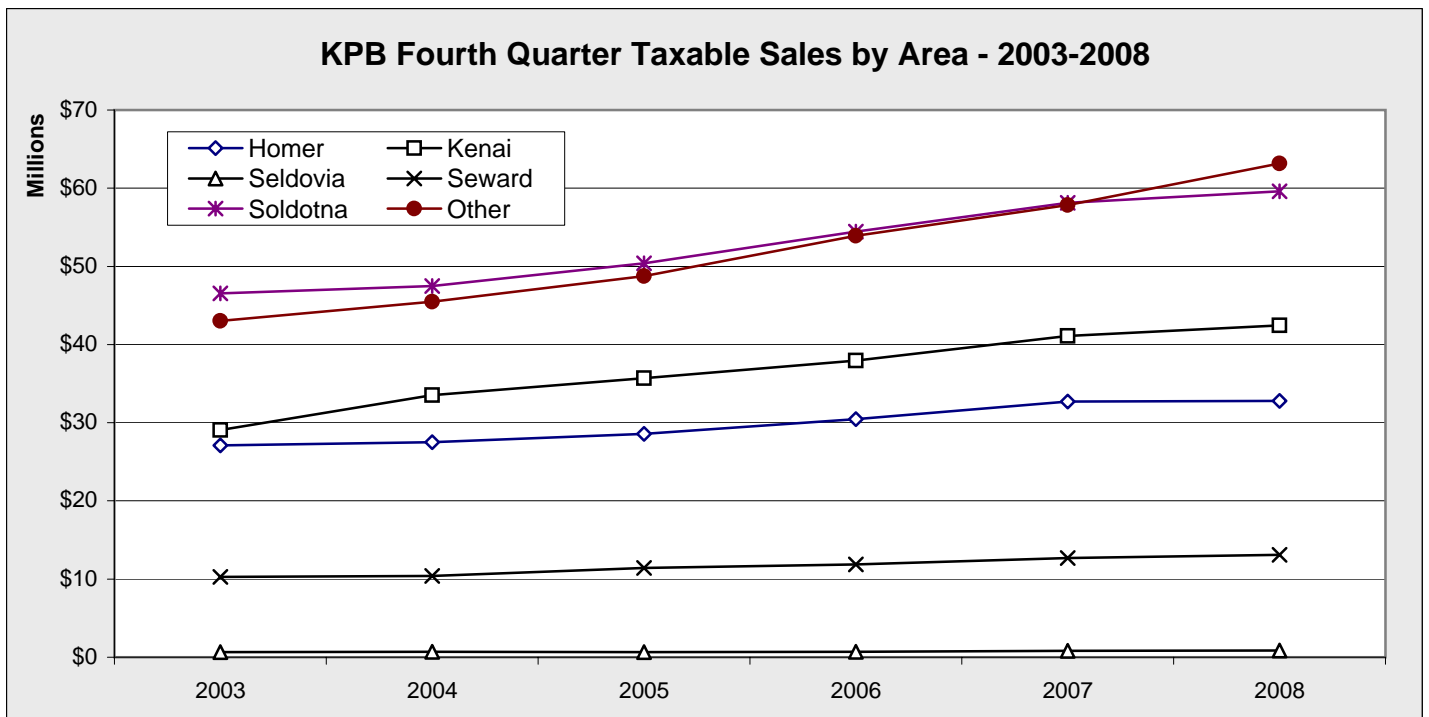

Chart 1.9

Fourth Quarter Taxable Sales Five Year Change by Area				
	2003	2008	Value Change	Percent Change
Homer	27,107,360	32,775,097	5,667,737	20.9%
Kenai	29,068,027	42,457,879	13,389,852	46.1%
Seldovia	674,689	857,233	182,544	27.1%
Seward	10,289,302	13,080,362	2,791,060	27.1%
Soldotna	46,558,340	59,587,854	13,029,514	28.0%
Other	43,042,009	63,144,175	20,102,166	46.7%
TOTAL	156,739,727	211,902,600	55,162,873	35.2%

Table 1.10

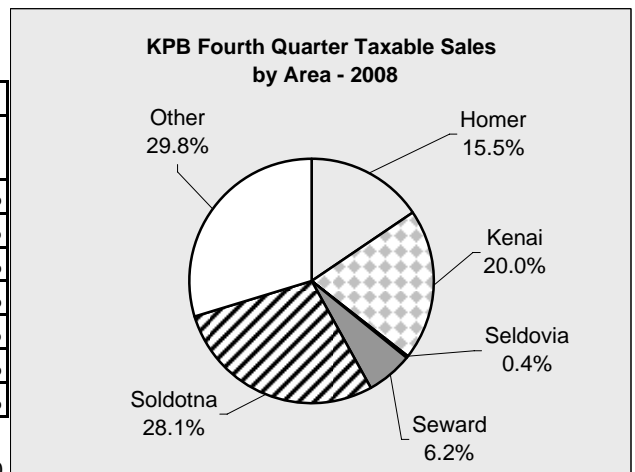

Chart 1.10

KPB Sales

KPB Annual GROSS Sales by Line of Business - 2003-2008 - in \$								
LOB	2003	2004	2005	2006	2007	2008	Annual Percent Change	Annual Amount Change
PROD	180,080,705	248,471,550	233,126,367	219,043,152	198,852,957	220,624,624	10.9%	21,771,667
SALES	613,498,417	594,768,014	619,847,086	656,477,507	693,839,923	809,475,081	16.7%	115,635,158
CONST	244,103,614	224,936,947	291,866,412	365,247,770	311,077,123	310,212,011	-0.3%	-865,112
PROP	79,494,242	80,829,427	83,245,670	88,788,876	94,849,370	99,601,202	5.0%	4,751,832
TOUR	160,905,161	179,320,386	189,073,158	203,203,773	207,455,951	155,553,194	-25.0%	-51,902,757
SERV	117,769,942	139,674,429	141,771,433	160,342,954	197,785,739	223,400,639	13.0%	25,614,900
PROF	53,795,685	59,110,980	59,456,967	67,089,875	69,077,290	75,773,077	9.7%	6,695,787
UTIL	79,515,989	87,509,276	103,471,296	120,040,958	121,319,850	136,700,502	12.7%	15,380,652
MFG	141,819,051	180,746,841	249,940,567	178,665,554	196,516,138	262,581,508	33.6%	66,065,370
TRAN	31,037,275	65,728,684	116,543,212	126,841,197	165,070,503	219,186,646	32.8%	54,116,143
WHSL	205,736,129	460,463,293	468,209,106	499,886,669	533,714,308	629,233,693	17.9%	95,519,385
GOV	13,606,580	14,545,420	15,214,964	15,685,700	16,366,837	17,314,932	5.8%	948,095
TOTAL	1,921,362,790	2,336,105,247	2,571,766,238	2,701,313,985	2,805,925,989	3,159,657,109	12.6%	353,731,120
Annual Change		21.6%	10.1%	5.0%	3.9%	12.6%		

Table 1.11

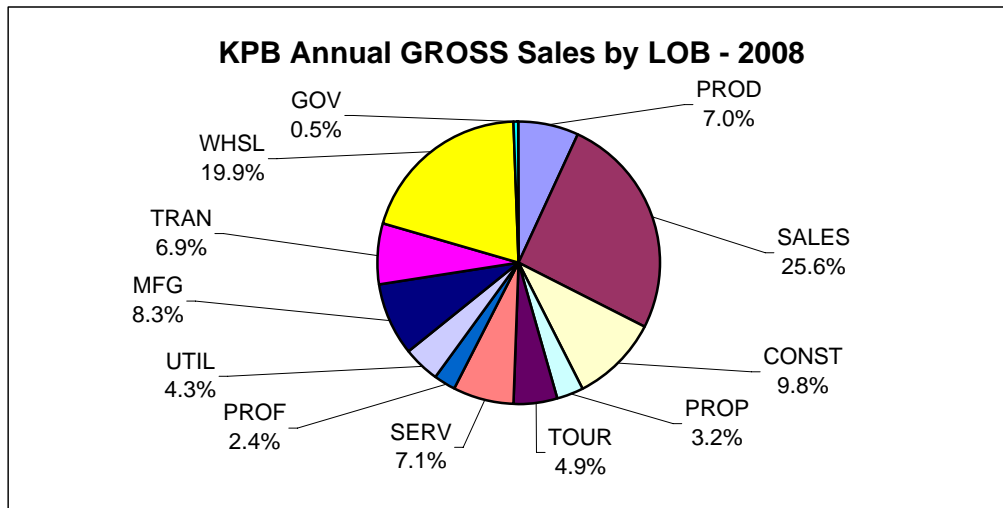

Chart 1.11

Annual GROSS Sales Five Year Change by LOB				
LOB	2003	2008	Value Change	Percent Change
PROD	180,080,705	220,624,624	40,543,919	22.5%
SALES	613,498,417	809,475,081	195,976,664	31.9%
CONST	244,103,614	310,212,011	66,108,397	27.1%
PROP	79,494,242	99,601,202	20,106,960	25.3%
TOUR	160,905,161	155,553,194	-5,351,967	-3.3%
SERV	117,769,942	223,400,639	105,630,697	89.7%
PROF	53,795,685	75,773,077	21,977,392	40.9%
UTIL	79,515,989	136,700,502	57,184,513	71.9%
MFG	141,819,051	262,581,508	120,762,457	85.2%
TRAN	31,037,275	219,186,646	188,149,371	606.2%
WHSL	205,736,129	629,233,693	423,497,564	205.8%
GOV	13,606,580	17,314,932	3,708,352	27.3%
TOTAL	1,921,362,790	3,159,657,109	1,238,294,319	64.4%

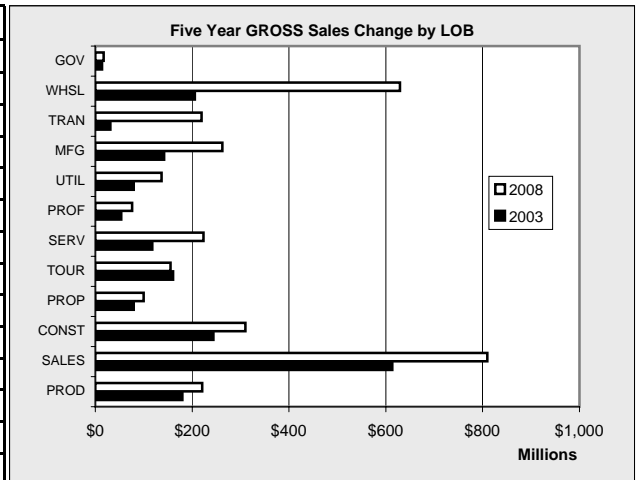

Table 1.12

Chart 1.12

KPB Sales

KPB Annual TAXABLE Sales by Line of Business - 2003-2008 - in \$

LOB	2003	2004	2005	2006	2007	2008	Annual Percent Change	Annual Amount Change
PROD	5,629,469	5,949,765	5,114,386	5,223,139	5,940,404	6,694,810	12.7%	754,406
SALES	363,365,826	370,936,218	390,887,293	417,851,705	452,696,833	538,927,936	19.0%	86,231,103
CONST	11,780,819	11,224,031	10,622,521	11,243,612	12,216,828	12,610,340	3.2%	393,512
PROP	31,745,396	32,273,771	32,691,193	34,622,371	39,227,330	41,708,890	6.3%	2,481,560
TOUR	134,633,782	145,285,573	153,201,396	163,802,197	180,512,107	132,133,153	-26.8%	-48,378,954
SERV	74,042,540	77,018,437	79,650,900	85,436,424	96,224,461	106,613,261	10.8%	10,388,800
PROF	14,210,619	14,693,620	14,917,338	16,151,644	17,153,213	17,695,101	3.2%	541,888
UTIL	35,022,919	36,146,549	41,032,308	48,825,218	53,435,892	56,985,954	6.6%	3,550,062
MFG	7,142,669	7,514,683	8,668,508	9,646,793	10,486,664	8,880,367	-15.3%	-1,606,297
TRAN	3,561,329	1,992,266	2,470,463	2,811,766	2,904,344	3,644,236	25.5%	739,892
WHSL	40,289,023	66,025,347	73,132,431	78,893,228	82,198,097	86,329,055	5.0%	4,130,958
GOV	11,696,775	12,288,242	13,034,058	13,433,539	14,194,814	14,631,227	3.1%	436,413
TOTAL	733,121,166	781,348,502	825,422,795	887,941,636	967,190,987	1,026,854,330	6.2%	59,663,343
Annual Change		6.6%	5.6%	7.6%	8.9%	6.2%		

Table 1.13

KPB Annual TAXABLE Sales by LOB - 2008

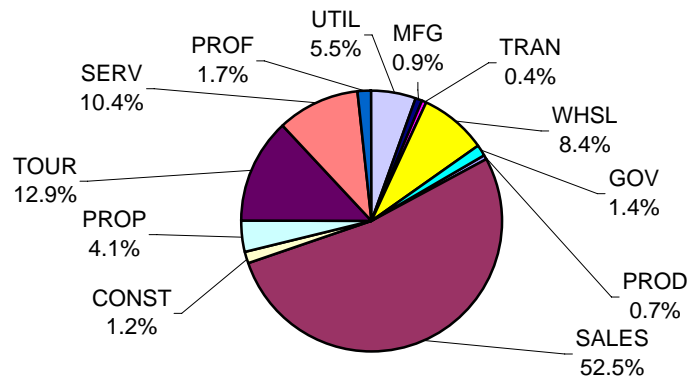

Chart 1.13

Annual TAXABLE Sales Five Year Change by LOB

	2003	2008	Value Change	Percent Change
PROD	5,629,469	6,694,810	1,065,341	18.9%
SALES	363,365,826	538,927,936	175,562,110	48.3%
CONST	11,780,819	12,610,340	829,521	7.0%
PROP	31,745,396	41,708,890	9,963,494	31.4%
TOUR	134,633,782	132,133,153	-2,500,629	-1.9%
SERV	74,042,540	106,613,261	32,570,721	44.0%
PROF	14,210,619	17,695,101	3,484,482	24.5%
UTIL	35,022,919	56,985,954	21,963,035	62.7%
MFG	7,142,669	8,880,367	1,737,698	24.3%
TRAN	3,561,329	3,644,236	82,907	2.3%
WHSL	40,289,023	86,329,055	46,040,032	114.3%
GOV	11,696,775	14,631,227	2,934,452	25.1%
TOTAL	733,121,166	1,026,854,330	293,733,164	40.1%

Table 1.14

Five Year TAXABLE Sales Change by LOB

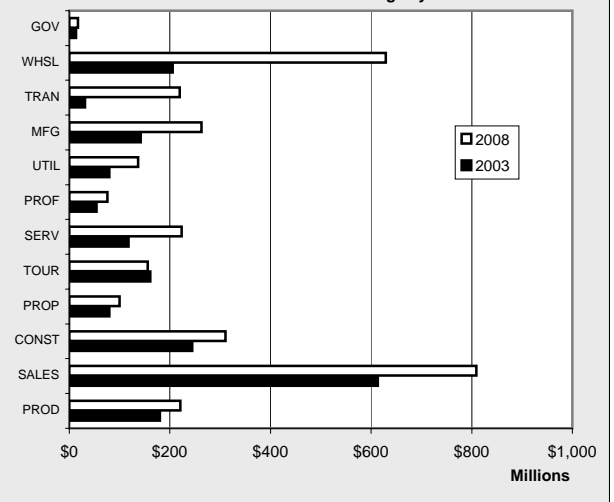

Chart 1.14

KPB Sales

KPB Annual NON-TAXABLE Sales by Line of Business - 2003-2008 - in \$								
LOB	2003	2004	2005	2006	2007	2008	Annual Percent Change	Annual Amount Change
PROD	174,451,236	242,521,785	228,011,981	213,820,013	192,912,553	213,929,814	10.9%	-20,907,460
SALES	250,132,591	223,831,796	228,959,793	238,625,802	241,143,090	270,547,145	12.2%	2,517,288
CONST	232,322,795	213,712,916	281,243,891	354,004,158	298,860,295	297,601,671	-0.4%	-55,143,863
PROP	47,748,846	48,555,656	50,554,477	54,166,505	55,622,040	57,892,312	4.1%	1,455,535
TOUR	26,271,379	34,034,813	35,871,762	39,401,576	26,943,844	23,420,041	-13.1%	-12,457,732
SERV	43,727,402	62,655,992	62,120,533	74,906,530	101,561,278	116,787,378	15.0%	26,654,748
PROF	39,585,066	44,417,360	44,539,629	50,938,231	51,924,077	58,077,976	11.9%	985,846
UTIL	44,493,070	51,362,727	62,438,988	71,215,740	67,883,958	79,714,548	17.4%	-3,331,782
MFG	134,676,382	173,232,158	241,272,059	169,018,761	186,029,474	253,701,141	36.4%	17,010,713
TRAN	27,475,946	63,736,418	114,072,749	124,029,431	162,166,159	215,542,410	32.9%	38,136,728
WHSL	165,447,106	394,437,946	395,076,675	420,993,441	451,516,211	542,904,638	20.2%	30,522,770
GOV	1,909,805	2,257,178	2,180,906	2,252,161	2,172,023	2,683,705	23.6%	-80,138
TOTAL	1,188,241,624	1,554,756,745	1,746,343,443	1,813,372,349	1,838,735,002	2,132,802,779	16.0%	25,362,653
Annual Change		30.8%	12.3%	3.8%	1.4%	16.0%		

Table 1.15

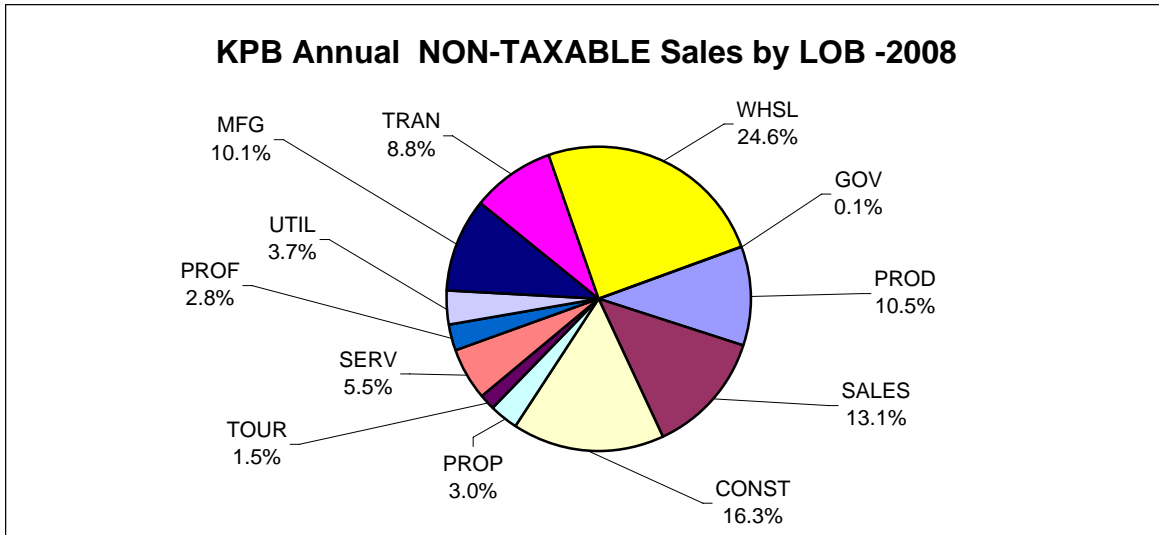

Chart 1.15

Annual NON-TAXABLE Sales Five Year Change by LOB				
	2003	2008	Value Change	Percent Change
PROD	174,451,236	192,912,553	18,461,317	10.6%
SALES	250,132,591	241,143,090	-8,989,501	-3.6%
CONST	232,322,795	298,860,295	66,537,500	28.6%
PROP	47,748,846	55,622,040	7,873,194	16.5%
TOUR	26,271,379	26,943,844	672,465	2.6%
SERV	43,727,402	101,561,278	57,833,876	132.3%
PROF	39,585,066	51,924,077	12,339,011	31.2%
UTIL	44,493,070	67,883,958	23,390,888	52.6%
MFG	134,676,382	186,029,474	51,353,092	38.1%
TRAN	27,475,946	162,166,159	134,690,213	490.2%
WHSL	165,447,106	451,516,211	286,069,105	172.9%
GOV	1,909,805	2,172,023	262,218	13.7%
TOTAL	1,188,241,624	1,838,735,002	650,493,378	54.7%

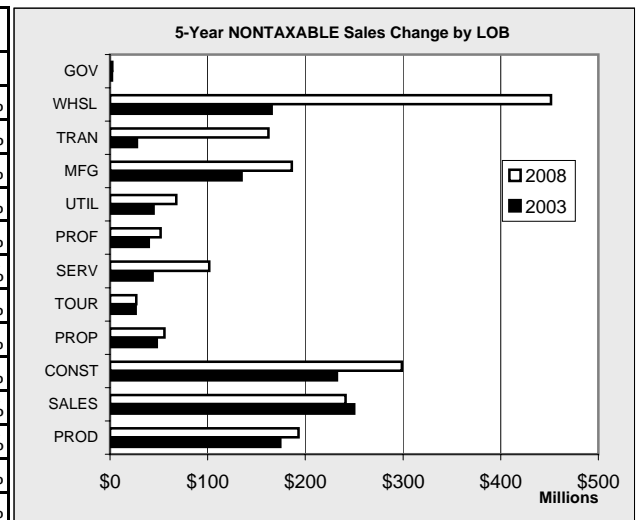

Table 1.16

Chart 1.16

KPB Sales

KPB Annual GROSS Sales by Area - 2003-2008 - in \$

	2003	2004	2005	2006	2007	2008	Annual Percent Change	Annual Amount Change
Homer	274,073,782	290,423,752	309,268,753	356,227,707	353,452,150	382,914,299	8.3%	29,462,149
Kenai	282,882,495	407,272,175	465,779,952	456,932,044	520,557,074	607,676,556	16.7%	87,119,482
Seldovia	7,259,554	8,329,831	6,871,279	7,564,723	9,495,815	8,530,781	-10.2%	-965,034
Seward	156,961,936	166,016,942	189,104,993	198,357,254	195,248,254	214,574,775	9.9%	19,326,521
Soldotna	337,906,000	361,258,879	396,033,463	432,855,181	429,295,387	465,405,888	8.4%	36,110,501
Other	862,279,023	1,102,803,668	1,204,707,798	1,249,377,076	1,297,877,309	1,480,554,810	14.1%	182,677,501
Total	1,921,362,790	2,336,105,247	2,571,766,238	2,701,313,985	2,805,925,989	3,159,657,109	12.6%	353,731,120
Annual Change		21.6%	10.1%	5.0%	3.9%	12.6%		

Table 1.17

KPB Annual Gross Sales by Area - 2003-2008

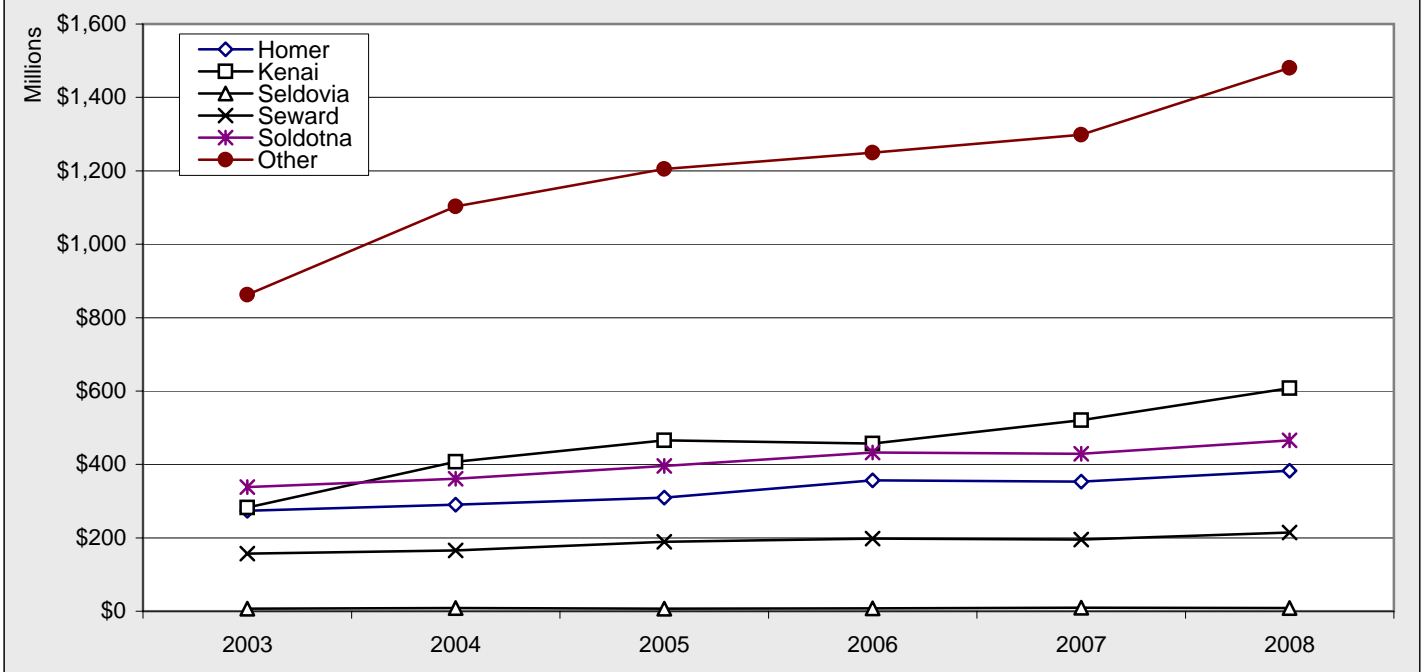

Chart 1.17

Annual Gross Sales Five Year Change by Area

	2003	2008	Value Change	Percent Change
Homer	274,073,782	382,914,299	108,840,517	39.7%
Kenai	282,882,495	607,676,556	324,794,061	114.8%
Seldovia	7,259,554	8,530,781	1,271,227	17.5%
Seward	156,961,936	214,574,775	57,612,839	36.7%
Soldotna	337,906,000	465,405,888	127,499,888	37.7%
Other	862,279,023	1,480,554,810	618,275,787	71.7%
TOTAL	1,921,362,790	3,159,657,109	1,238,294,319	64.4%

Table 1.18

KPB Annual Gross Sales by Area - 2008

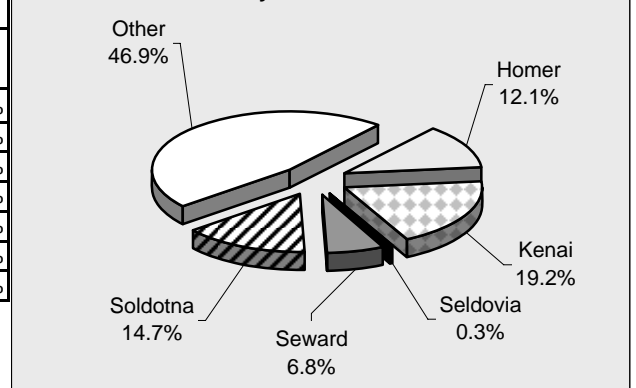

Chart 1.18

KPB Sales

KPB Annual TAXABLE Sales by Area - 2003-2008 - in \$								
	2003	2004	2005	2006	2007	2008	Annual Percent Change	Annual Amount Change
Homer	131,729,196	139,975,581	144,757,649	153,385,392	166,500,949	173,010,794	3.9%	6,509,845
Kenai	121,314,795	139,373,862	145,536,054	156,640,595	167,077,378	175,891,484	5.3%	8,814,106
Seldovia	3,376,944	3,386,312	3,380,980	3,671,079	4,317,728	5,004,876	15.9%	687,148
Seward	76,348,733	79,767,208	87,749,003	91,089,954	102,255,726	105,003,769	2.7%	2,748,043
Soldotna	190,627,772	200,059,548	211,210,444	227,545,027	243,495,221	261,094,783	7.2%	17,599,562
Other	209,723,726	218,785,991	232,788,665	255,609,589	283,543,985	306,848,624	8.2%	23,304,639
Total	733,121,166	781,348,502	825,422,795	887,941,636	967,190,987	1,026,854,330	6.2%	59,663,343
Annual Change		6.6%	5.6%	7.6%	8.9%	6.2%		

Table 1.19

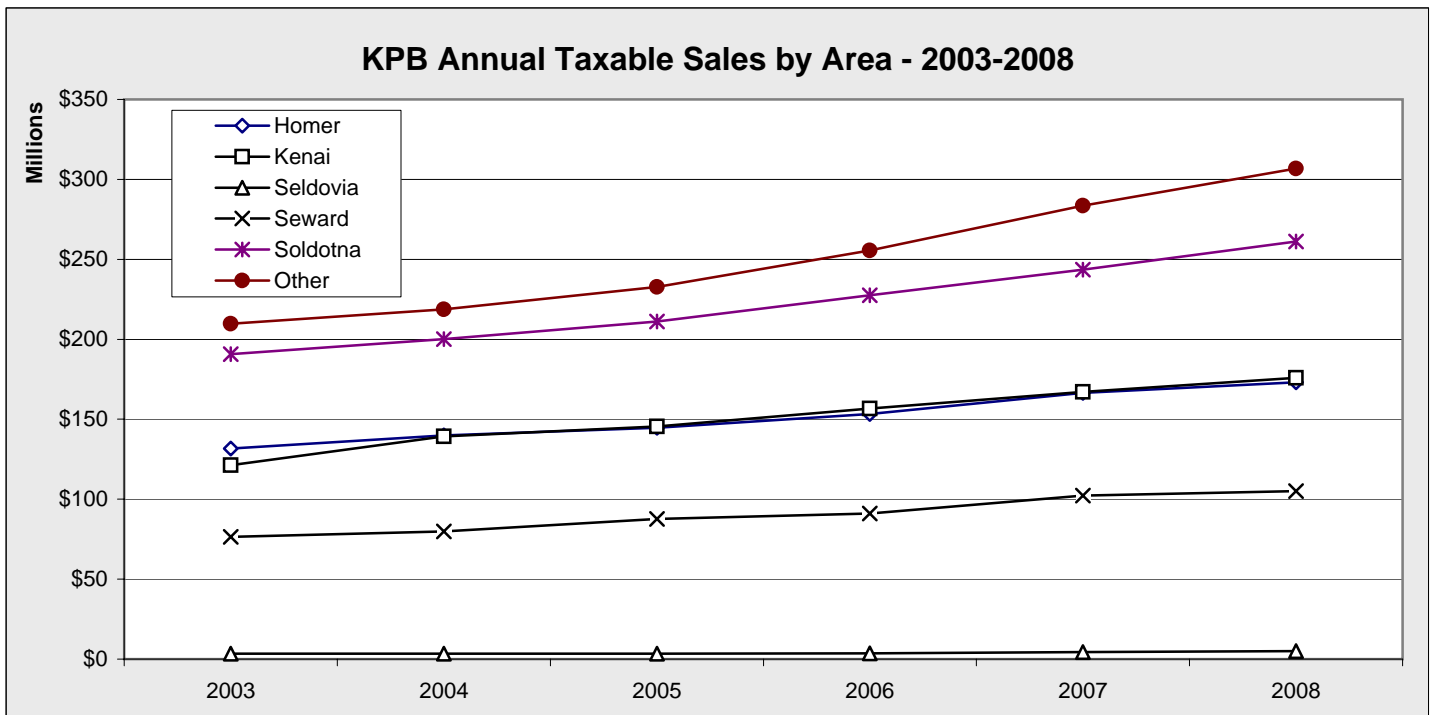

Chart 1.19

Annual Taxable Sales Five Year Change by Area				
	2003	2008	Value Change	Percent Change
Homer	131,729,196	173,010,794	41,281,598	31.3%
Kenai	121,314,795	175,891,484	54,576,689	45.0%
Seldovia	3,376,944	5,004,876	1,627,932	48.2%
Seward	76,348,733	105,003,769	28,655,036	37.5%
Soldotna	190,627,772	261,094,783	70,467,011	37.0%
Other	209,723,726	306,848,624	97,124,898	46.3%
TOTAL	733,121,166	1,026,854,330	293,733,164	40.1%

Table 1.20

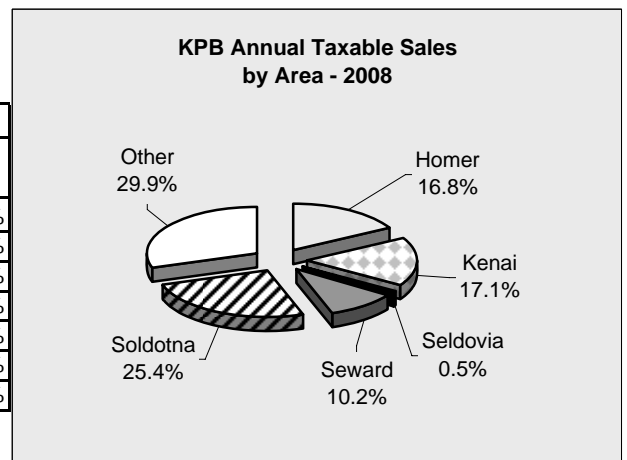

Chart 1.20

KPB Sales

KPB Annual NON-TAXABLE Sales by Area - 2003-2008 - in \$

	2003	2004	2005	2006	2007	2008	Annual Percent Change	Annual Amount Change
Homer	142,344,586	150,448,171	164,511,104	202,842,315	186,951,201	209,903,505	12.3%	22,952,304
Kenai	161,567,700	267,898,313	320,243,898	300,291,449	353,479,696	431,785,072	22.2%	78,305,376
Seldovia	3,882,610	4,943,519	3,490,299	3,893,644	5,178,087	3,525,905	-31.9%	-1,652,182
Seward	80,613,203	86,249,734	101,355,990	107,267,300	92,992,528	109,571,006	17.8%	16,578,478
Soldotna	147,278,228	161,199,331	184,823,019	205,310,154	185,800,166	204,311,105	10.0%	18,510,939
Other	652,555,297	884,017,677	971,919,133	993,767,487	1,014,333,324	1,173,706,186	15.7%	159,372,862
Total	1,188,241,624	1,554,756,745	1,746,343,443	1,813,372,349	1,838,735,002	2,132,802,779	16.0%	294,067,777
Annual Change		30.8%	12.3%	3.8%	1.4%	16.0%		

Table 1.21

KPB Annual Non-Taxable Sales by Area - 2003-2008

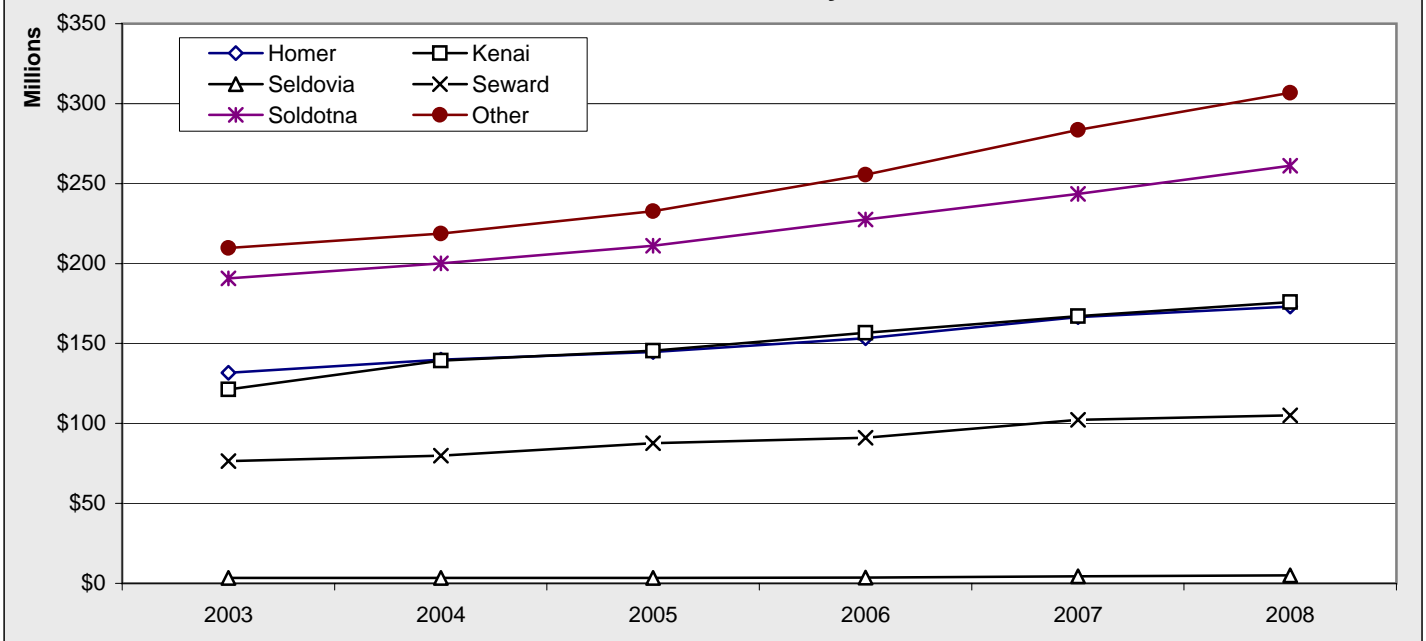

Chart 1.21

Non-Taxable Sales Five Year Change by Area

	2003	2008	Value Change	Percent Change
Homer	142,344,586	209,903,505	67,558,919	47.5%
Kenai	161,567,700	431,785,072	270,217,372	167.2%
Seldovia	3,882,610	3,525,905	-356,705	-9.2%
Seward	80,613,203	109,571,006	28,957,803	35.9%
Soldotna	147,278,228	204,311,105	57,032,877	38.7%
Other	652,555,297	1,173,706,186	521,150,889	79.9%
TOTAL	1,188,241,624	2,132,802,779	944,561,155	79.5%

Table 1.22

KPB Annual Non-Taxable Sales by Area - 2008

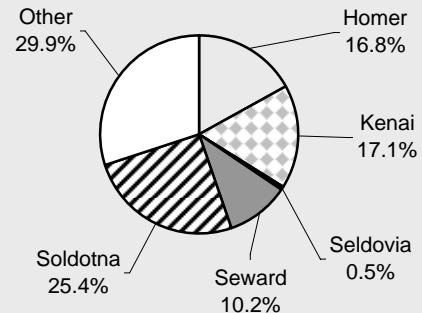

Chart 1.22

KPB Sales

KPB Annual GROSS Sales by LOB by Quarter - 2008 - in \$					
LOB	1st Quarter	2nd Quarter	3rd Quarter	4th Quarter	Total
PROD	28,399,783	41,226,009	51,993,400	99,005,432	220,624,624
SALES	147,230,051	209,904,567	261,798,968	190,541,495	809,475,081
CONST	46,451,878	66,812,991	104,165,596	92,781,546	310,212,011
PROP	19,005,545	25,231,660	30,162,850	25,201,147	99,601,202
TOUR	8,149,740	47,175,954	89,978,836	10,248,664	155,553,194
SERV	43,518,244	62,153,219	65,159,602	52,569,574	223,400,639
PROF	15,036,479	18,233,426	19,108,411	23,394,761	75,773,077
UTIL	35,696,808	29,774,744	30,780,619	40,448,331	136,700,502
MFG	38,544,973	80,895,890	104,586,640	38,554,005	262,581,508
TRAN	40,015,969	57,776,253	69,090,301	52,304,123	219,186,646
WHSL	64,212,311	91,634,047	104,580,326	368,807,009	629,233,693
GOV	3,421,715	3,943,328	5,690,831	4,259,058	17,314,932
TOTAL	489,683,496	734,762,088	937,096,380	998,115,145	3,159,657,109

Table 1.23

KPB Annual GROSS Sales by Area by Quarter - 2008 - in \$					
	1st Quarter	2nd Quarter	3rd Quarter	4th Quarter	Total
Homer	65,708,118	103,215,060	125,955,296	88,035,825	382,914,299
Kenai	108,812,075	146,580,463	182,488,483	169,795,535	607,676,556
Seldovia	1,516,251	2,591,665	2,347,161	2,075,704	8,530,781
Seward	26,506,069	59,814,396	89,445,765	38,808,545	214,574,775
Soldotna	89,538,030	112,456,040	146,420,303	116,991,515	465,405,888
Other	197,602,952	310,104,465	390,439,372	582,408,021	1,480,554,810
Total	489,683,495	734,762,089	937,096,380	998,115,145	3,159,657,109

Table 1.24

KPB Annual TAXABLE Sales by LOB by Quarter - 2008 - in \$					
LOB	1st Quarter	2nd Quarter	3rd Quarter	4th Quarter	Total
PROD	1,008,753	2,216,863	1,748,758	1,720,436	6,694,810
SALES	95,601,390	138,921,134	185,402,282	119,003,130	538,927,936
CONST	2,374,653	3,082,212	3,914,197	3,239,278	12,610,340
PROP	7,918,408	10,883,931	13,305,391	9,601,160	41,708,890
TOUR	6,889,798	40,898,248	77,011,482	7,333,625	132,133,153
SERV	22,343,938	27,505,793	31,168,849	25,594,681	106,613,261
PROF	4,269,130	4,744,076	4,688,193	3,993,702	17,695,101
UTIL	16,634,798	12,793,542	11,107,978	16,449,636	56,985,954
MFG	961,058	2,352,036	4,211,685	1,355,588	8,880,367
TRAN	562,731	1,008,526	1,277,653	795,326	3,644,236
WHSL	17,059,910	23,271,188	26,815,958	19,181,999	86,329,055
GOV	2,732,211	3,458,001	4,806,976	3,634,039	14,631,227
TOTAL	178,356,778	271,135,550	365,459,402	211,902,600	1,026,854,330

Table 1.25

KPB Annual TAXABLE Sales by Area by Quarter - 2008 - in \$					
	1st Quarter	2nd Quarter	3rd Quarter	4th Quarter	Total
Homer	29,022,917	48,871,596	62,341,184	32,775,097	173,010,794
Kenai	36,199,394	44,860,208	52,374,003	42,457,879	175,891,484
Seldovia	850,232	1,663,391	1,634,020	857,233	5,004,876
Seward	11,339,653	30,194,399	50,389,355	13,080,362	105,003,769
Soldotna	47,660,551	63,179,312	90,667,066	59,587,854	261,094,783
Other	53,284,030	82,366,645	108,053,774	63,144,175	306,848,624
Total	178,356,777	271,135,551	365,459,402	211,902,600	1,026,854,330

Table 1.26

KPB Sales

KPB Annual GROSS Sales by LOB by Quarter - 2007 - in \$					
LOB	1st Quarter	2nd Quarter	3rd Quarter	4th Quarter	Total
PROD	24,974,260	37,089,155	43,860,460	92,929,082	198,852,957
SALES	127,448,205	181,702,272	218,992,332	165,697,114	693,839,923
CONST	47,528,741	71,115,474	96,207,346	96,225,562	311,077,123
PROP	17,951,988	23,009,451	27,572,825	26,315,106	94,849,370
TOUR	18,936,404	59,439,612	108,920,809	20,159,126	207,455,951
SERV	37,198,517	53,832,707	58,113,534	48,640,981	197,785,739
PROF	14,926,273	15,388,743	16,507,916	22,254,358	69,077,290
UTIL	37,984,202	30,112,352	20,940,611	32,282,685	121,319,850
MFG	45,887,281	46,774,719	85,026,281	18,827,857	196,516,138
TRAN	36,805,498	34,761,160	50,920,772	42,583,073	165,070,503
WHSL	48,617,298	67,298,261	83,966,334	333,832,415	533,714,308
GOV	3,228,263	3,968,840	5,039,313	4,130,421	16,366,837
TOTAL	461,486,930	624,492,746	816,068,533	903,877,780	2,805,925,989

Table 1.27

KPB Annual GROSS Sales by Area by Quarter - 2007 - in \$					
	1st Quarter	2nd Quarter	3rd Quarter	4th Quarter	Total
Homer	61,424,512	97,290,718	113,727,381	81,009,539	353,452,150
Kenai	96,678,365	111,960,372	152,995,834	158,922,503	520,557,074
Seldovia	1,462,524	2,550,793	2,130,764	3,351,734	9,495,815
Seward	25,608,135	56,608,855	78,382,897	34,648,367	195,248,254
Soldotna	79,259,451	102,966,180	130,199,945	116,869,811	429,295,387
Other	197,053,944	253,115,826	338,631,713	509,075,826	1,297,877,309
Total	461,486,931	624,492,744	816,068,534	903,877,780	2,805,925,989

Table 1.28

KPB Annual TAXABLE Sales by LOB by Quarter - 2007 - in \$					
LOB	1st Quarter	2nd Quarter	3rd Quarter	4th Quarter	Total
PROD	894,819	2,039,567	1,570,128	1,435,890	5,940,404
SALES	80,780,970	117,658,028	149,604,085	104,653,750	452,696,833
CONST	2,174,970	3,034,410	3,698,378	3,309,070	12,216,828
PROP	7,356,863	9,952,399	12,274,904	9,643,164	39,227,330
TOUR	16,073,170	53,007,670	94,466,360	16,964,907	180,512,107
SERV	19,244,573	25,559,364	28,089,546	23,330,978	96,224,461
PROF	4,134,921	4,611,238	4,388,635	4,018,419	17,153,213
UTIL	17,578,615	11,944,498	10,474,300	13,438,479	53,435,892
MFG	1,233,175	2,817,887	4,774,431	1,661,171	10,486,664
TRAN	425,345	791,238	900,948	786,813	2,904,344
WHSL	16,366,742	21,240,013	24,090,040	20,501,302	82,198,097
GOV	2,855,994	3,446,756	4,347,718	3,544,346	14,194,814
TOTAL	169,120,157	256,103,068	338,679,473	203,288,289	967,190,987

Table 1.29

KPB Annual TAXABLE Sales by Area by Quarter - 2007 - in \$					
	1st Quarter	2nd Quarter	3rd Quarter	4th Quarter	Total
Homer	27,254,559	47,168,234	59,366,059	32,712,097	166,500,949
Kenai	34,313,793	43,096,842	48,556,382	41,110,361	167,077,378
Seldovia	755,801	1,220,836	1,508,876	832,215	4,317,728
Seward	10,869,898	30,040,462	48,661,876	12,683,490	102,255,726
Soldotna	45,881,620	59,407,136	80,093,167	58,113,298	243,495,221
Other	50,044,487	75,169,557	100,493,113	57,836,828	283,543,985
Total	169,120,158	256,103,067	338,679,473	203,288,289	967,190,987

Table 1.30

KPB Sales

KPB Annual GROSS Sales by LOB by Quarter - 2006 - in \$					
LOB	1st Quarter	2nd Quarter	3rd Quarter	4th Quarter	Total
PROD	41,274,840	43,839,219	62,118,237	71,810,856	219,043,152
SALES	119,035,596	178,965,036	206,143,237	152,333,638	656,477,507
CONST	31,974,205	59,781,577	97,217,621	176,274,367	365,247,770
PROP	17,365,603	22,740,383	25,835,246	22,847,644	88,788,876
TOUR	17,398,131	58,865,867	106,305,678	20,634,097	203,203,773
SERV	32,231,969	42,838,322	43,893,954	41,378,709	160,342,954
PROF	14,136,142	14,165,049	15,548,787	23,239,897	67,089,875
UTIL	32,447,128	26,961,172	26,505,508	34,127,150	120,040,958
MFG	20,273,690	55,022,566	68,436,833	34,932,465	178,665,554
TRAN	10,675,096	37,237,524	40,847,624	38,080,953	126,841,197
WHSL	47,733,746	68,421,938	77,931,201	305,799,784	499,886,669
GOV	3,126,281	3,670,790	4,731,516	4,157,113	15,685,700
TOTAL	387,672,427	612,509,443	775,515,442	925,616,673	2,701,313,985

Table 1.31

KPB Annual GROSS Sales by Area by Quarter - 2006 - in \$					
	1st Quarter	2nd Quarter	3rd Quarter	4th Quarter	Total
Homer	56,156,763	89,314,280	118,463,107	92,293,557	356,227,707
Kenai	63,273,640	109,278,718	121,537,938	162,841,748	456,932,044
Seldovia	1,517,120	2,170,811	2,529,588	1,347,204	7,564,723
Seward	21,701,206	51,092,715	75,592,879	49,970,454	198,357,254
Soldotna	72,457,151	99,012,814	121,167,794	140,217,422	432,855,181
Other	172,566,546	261,640,105	336,224,136	478,946,289	1,249,377,076
Total	387,672,426	612,509,443	775,515,442	925,616,674	2,701,313,985

Table 1.32

KPB Annual TAXABLE Sales by LOB by Quarter - 2006 - in \$					
LOB	1st Quarter	2nd Quarter	3rd Quarter	4th Quarter	Total
PROD	865,170	1,823,191	1,329,079	1,205,699	5,223,139
SALES	74,586,992	109,433,886	137,489,167	96,341,660	417,851,705
CONST	1,990,771	2,944,819	3,306,229	3,001,793	11,243,612
PROP	6,936,051	8,531,207	10,729,981	8,425,132	34,622,371
TOUR	15,899,091	48,415,782	81,959,541	17,527,783	163,802,197
SERV	18,046,491	22,111,917	24,398,224	20,879,792	85,436,424
PROF	4,046,431	4,536,924	3,964,046	3,604,243	16,151,644
UTIL	14,962,505	10,663,883	9,087,067	14,111,763	48,825,218
MFG	1,272,729	2,446,548	4,224,455	1,703,061	9,646,793
TRAN	478,235	889,688	912,143	531,700	2,811,766
WHSL	15,226,750	20,819,810	24,110,681	18,735,987	78,893,228
GOV	2,683,072	3,244,865	4,214,700	3,290,902	13,433,539
TOTAL	156,994,288	235,862,520	305,725,313	189,359,515	887,941,636

Table 1.33

KPB Annual TAXABLE Sales by Area by Quarter - 2006 - in \$					
	1st Quarter	2nd Quarter	3rd Quarter	4th Quarter	Total
Homer	25,717,626	43,368,152	53,836,629	30,462,985	153,385,392
Kenai	32,390,215	41,096,929	45,216,664	37,936,787	156,640,595
Seldovia	636,694	974,499	1,348,064	711,822	3,671,079
Seward	10,170,662	26,596,215	42,438,197	11,884,880	91,089,954
Soldotna	42,117,565	55,438,172	75,557,720	54,431,570	227,545,027
Other	45,961,527	68,388,554	87,328,037	53,931,471	255,609,589
Total	156,994,289	235,862,521	305,725,311	189,359,515	887,941,636

Table 1.34

KPB Sales

KPB Annual GROSS Sales by LOB by Quarter - 2005 - in \$					
LOB	1st Quarter	2nd Quarter	3rd Quarter	4th Quarter	Total
PROD	38,011,490	33,642,771	41,473,586	119,998,520	233,126,367
SALES	113,648,812	168,091,583	195,355,030	142,751,661	619,847,086
CONST	38,483,190	66,443,812	75,663,732	111,275,678	291,866,412
PROP	15,005,828	20,731,568	23,663,215	23,845,059	83,245,670
TOUR	16,292,977	54,963,368	98,426,275	19,390,538	189,073,158
SERV	28,623,999	37,026,822	39,585,448	36,535,164	141,771,433
PROF	12,543,218	11,903,224	13,373,844	21,636,681	59,456,967
UTIL	27,279,722	23,278,511	26,333,258	26,579,805	103,471,296
MFG	33,061,008	58,551,604	116,074,442	42,253,513	249,940,567
TRAN	24,457,384	36,061,931	17,881,873	38,142,024	116,543,212
WHSL	55,790,599	65,621,437	74,859,753	271,937,317	468,209,106
GOV	2,999,901	3,414,800	4,874,984	3,925,279	15,214,964
TOTAL	406,198,128	579,731,431	727,565,440	858,271,239	2,571,766,238

Table 1.35

KPB Annual GROSS Sales by Area by Quarter - 2005 - in \$					
	1st Quarter	2nd Quarter	3rd Quarter	4th Quarter	Total
Homer	51,885,093	85,895,824	100,977,789	70,510,047	309,268,753
Kenai	75,641,521	102,543,222	112,340,508	175,254,701	465,779,952
Seldovia	1,261,735	2,120,534	2,275,335	1,213,675	6,871,279
Seward	26,472,186	58,409,308	70,009,818	34,213,681	189,104,993
Soldotna	65,958,153	87,630,570	113,939,869	128,504,871	396,033,463
Other	184,979,440	243,131,973	328,022,121	448,574,264	1,204,707,798
Total	406,198,128	579,731,431	727,565,440	858,271,239	2,571,766,238

Table 1.36

KPB Annual TAXABLE Sales by LOB by Quarter - 2005 - in \$					
LOB	1st Quarter	2nd Quarter	3rd Quarter	4th Quarter	Total
PROD	954,695	1,790,259	1,187,436	1,181,996	5,114,386
SALES	69,744,866	103,212,569	128,395,123	89,534,735	390,887,293
CONST	1,947,107	2,908,756	3,100,842	2,665,816	10,622,521
PROP	6,658,361	8,187,746	10,110,343	7,734,743	32,691,193
TOUR	14,848,579	45,271,944	76,420,240	16,660,633	153,201,396
SERV	17,079,882	20,854,296	22,379,848	19,336,874	79,650,900
PROF	3,802,783	3,953,049	3,797,479	3,364,027	14,917,338
UTIL	12,169,072	9,357,261	8,389,891	11,116,084	41,032,308
MFG	816,272	2,035,398	3,987,892	1,828,946	8,668,508
TRAN	386,935	645,635	768,202	669,691	2,470,463
WHSL	13,543,440	19,096,007	22,162,375	18,330,609	73,132,431
GOV	2,575,030	3,081,459	4,282,656	3,094,913	13,034,058
TOTAL	144,527,022	220,394,379	284,982,327	175,519,067	825,422,795

Table 1.37

KPB Annual TAXABLE Sales by Area by Quarter - 2005 - in \$					
	1st Quarter	2nd Quarter	3rd Quarter	4th Quarter	Total
Homer	24,336,691	41,201,861	50,641,860	28,577,237	144,757,649
Kenai	29,608,133	37,518,001	42,697,902	35,712,018	145,536,054
Seldovia	573,017	932,141	1,215,676	660,146	3,380,980
Seward	10,094,338	25,309,646	40,943,244	11,401,775	87,749,003
Soldotna	38,716,680	52,146,002	69,952,376	50,395,386	211,210,444
Other	41,198,163	63,286,728	79,531,269	48,772,505	232,788,665
Total	144,527,022	220,394,379	284,982,327	175,519,067	825,422,795

Table 1.38

KPB Construction Permits

Construction Permitting

Construction permits are not required within the KPB except within the incorporated cities of Homer, Kenai, Seldovia, Seward and Soldotna; therefore, reported data does not include all KPB construction activity. It does, however, provide city trends. Permit categories include Residential New (RN), Residential Alteration/Addition (RA), Commercial New (CN) and Commercial Alteration/Addition (CA). Individual cities may have other categories, but in an effort to provide category consistency, city categories have been combined into one of the four. Homer, Kenai, Seldovia and Soldotna permit activity has been recorded since 1986 but Seward did not require building permits until 1988.

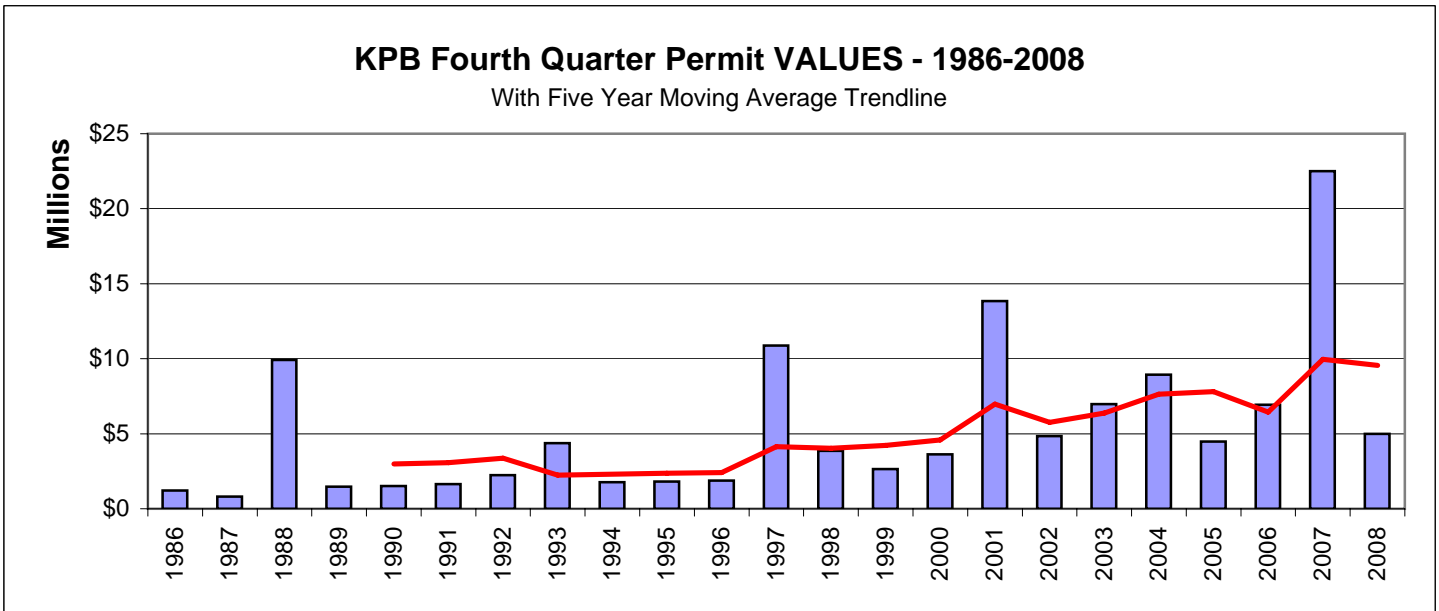

Chart 1.23

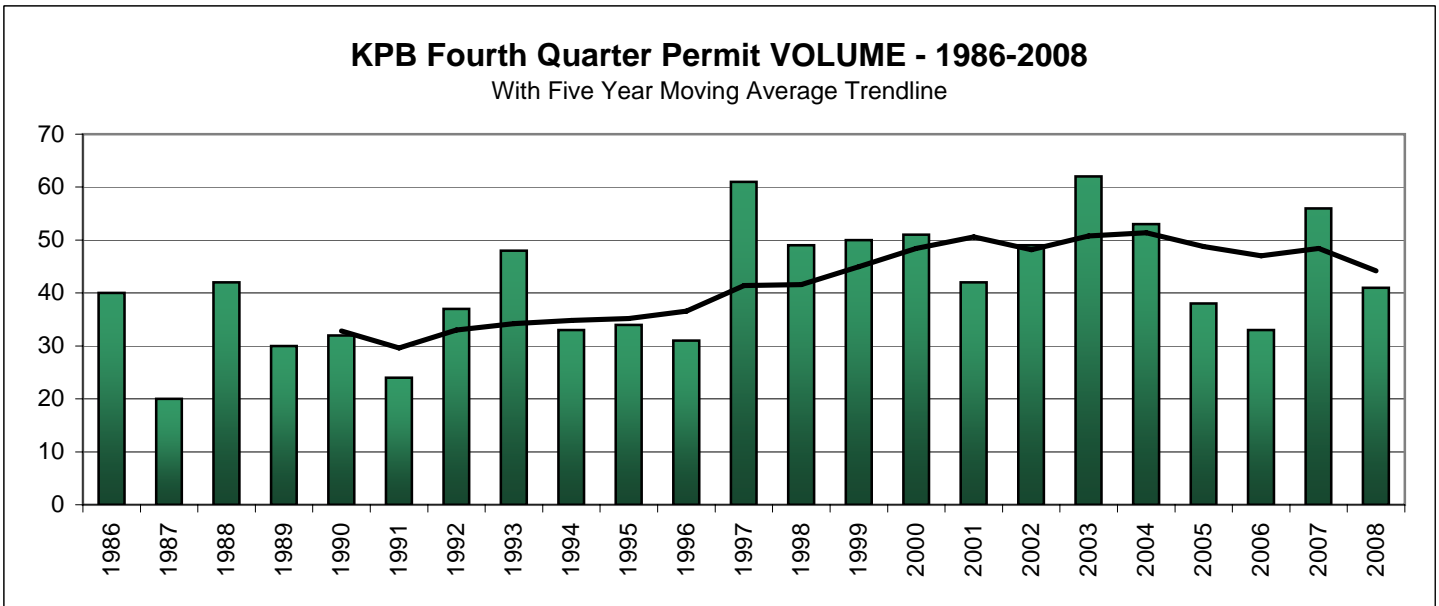

Chart 1.24

KPB Construction Permits

KPB Fourth Quarter Permit VALUES by Area - 2003-2008 - in \$							
	2003	2004	2005	2006	2007	2008	Annual Change
Homer	3,042,900	3,391,000	2,977,000	2,555,000	1,622,000	2,884,000	77.8%
Kenai	2,455,500	585,400	1,220,000	1,787,900	439,700	1,465,875	233.4%
Seldovia	36,500	0	500	18,000	1,000	10,000	900.0%
Seward	572,500	259,350	106,857	1,944,300	18,139,500	362,000	-98.0%
Soldotna	873,045	4,703,915	169,840	632,882	2,292,045	264,146	-88.5%
Total	6,980,445	8,939,665	4,474,197	6,938,082	22,494,245	4,986,021	-77.8%
Annual Change		28.1%	-50.0%	55.1%	224.2%	-77.8%	

Table 1.39

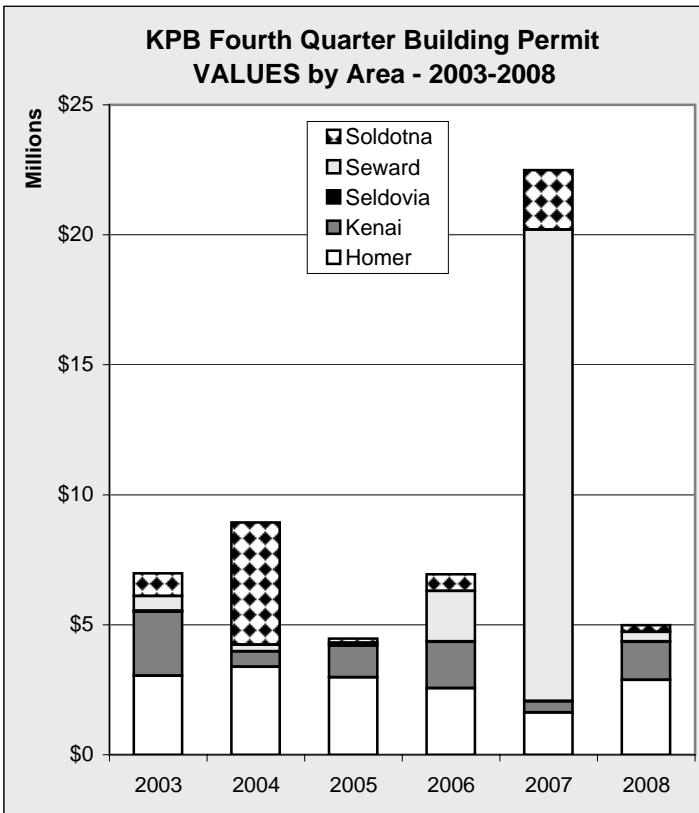

Chart 1.25

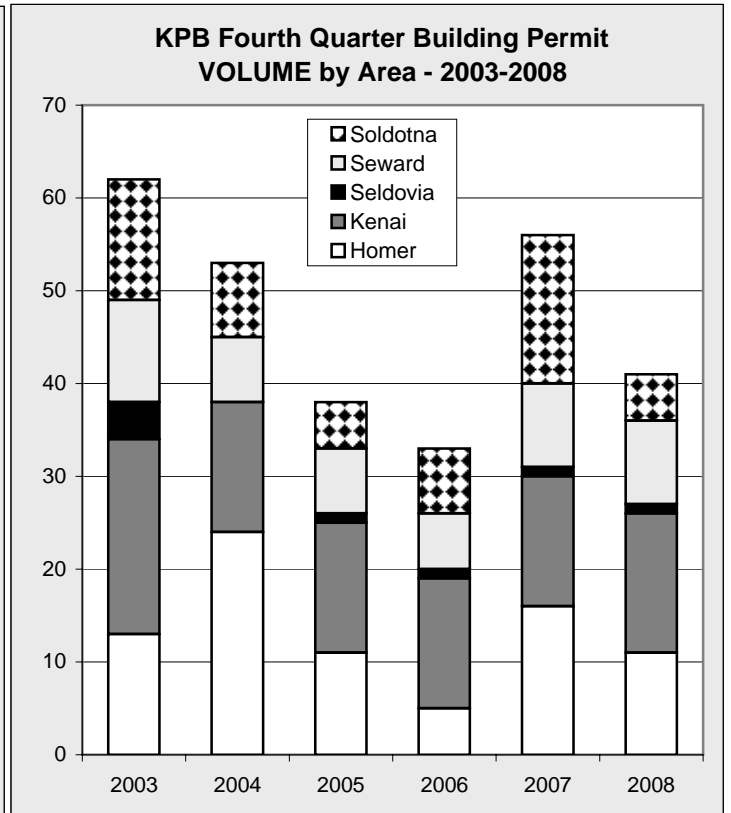

Chart 1.26

KPB Fourth Quarter Permit VOLUME by Area - 2003-2008							
	2003	2004	2005	2006	2007	2008	Annual Change
Homer	13	24	11	5	16	11	-31.3%
Kenai	21	14	14	14	14	15	7.1%
Seldovia	4	0	1	1	1	1	0.0%
Seward	11	7	7	6	9	9	0.0%
Soldotna	13	8	5	7	16	5	-68.8%
Total	62	53	38	33	56	41	-26.8%
Annual Change		-14.5%	-28.3%	-13.2%	69.7%	-26.8%	

Table 1.40

KPB Construction Permits

KPB Fourth Quarter Permit VALUES by Type - 2003-2008 - in \$							
	2003	2004	2005	2006	2007	2008	Annual Change
Residential New	2,554,091	1,153,860	2,007,623	2,056,833	933,000	1,628,875	74.6%
Residential Alter/Add	291,000	529,454	200,957	307,359	876,365	852,000	-2.8%
Commercial New	2,146,991	3,061,601	2,163,000	4,271,300	19,955,112	921,146	-95.4%
Commercial Alter/Add	1,988,363	4,194,750	102,617	302,590	729,768	1,584,000	117.1%
Total	6,980,445	8,939,665	4,474,197	6,938,082	22,494,245	4,986,021	-77.8%
Annual Change		28.1%	-50.0%	55.1%	224.2%	-77.8%	

Table 1.41

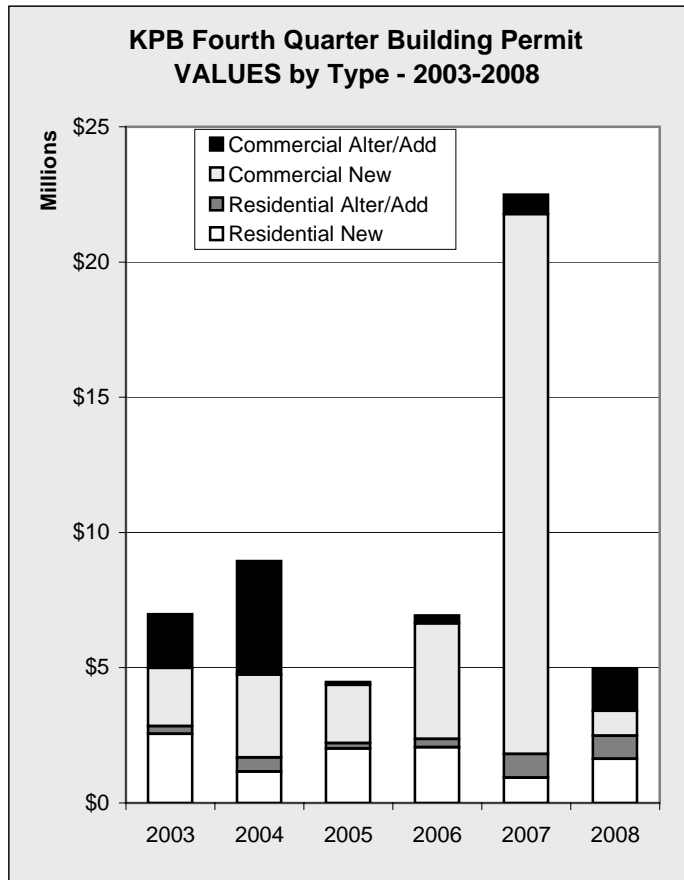

Chart 1.27

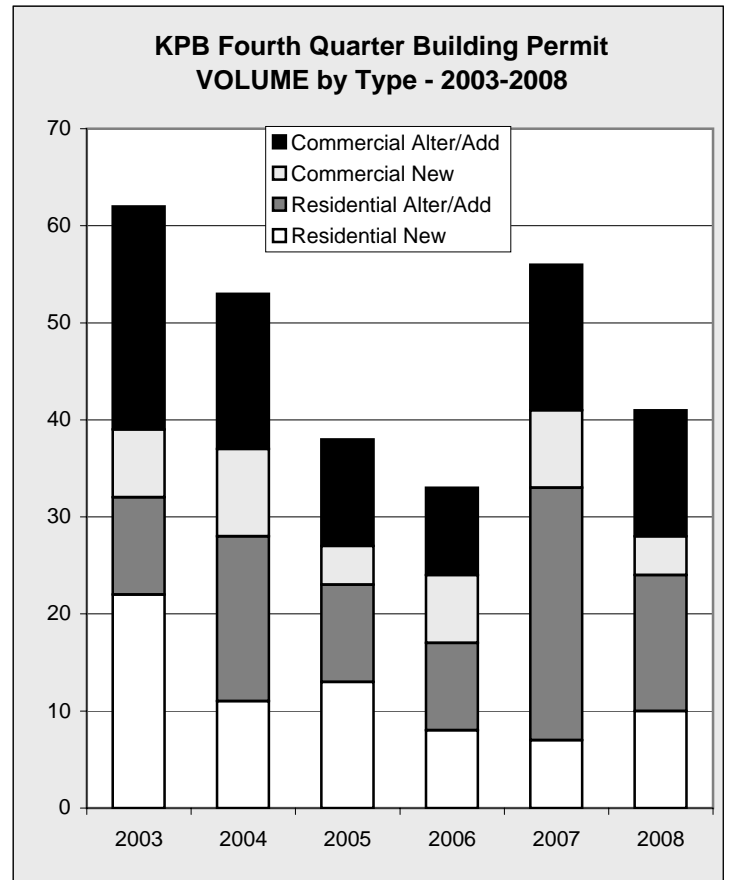

Chart 1.28

KPB Fourth Quarter Permit VOLUME by Type - 2003-2008							
	2003	2004	2005	2006	2007	2008	Annual Change
Residential New	22	11	13	8	7	10	42.9%
Residential Alter/Add	10	17	10	9	26	14	-46.2%
Commercial New	7	9	4	7	8	4	-50.0%
Commercial Alter/Add	23	16	11	9	15	13	-13.3%
Total	62	53	38	33	56	41	-26.8%
Annual Change		-14.5%	-28.3%	-13.2%	69.7%	-26.8%	

Table 1.42

KPB Construction Permits

KPB Annual Permit VALUES by Area - 2003 - 2008 - in \$							
	2003	2004	2005	2006	2007	2008	Annual Change
Homer	15,326,815	24,070,631	21,611,400	20,287,857	14,056,202	23,168,200	64.8%
Kenai	10,441,800	4,786,550	8,237,900	11,076,154	22,398,000	46,486,375	107.5%
Seldovia	1,902,500	176,200	512,000	135,000	343,800	382,500	11.3%
Seward	7,982,765	17,711,150	2,863,143	25,537,249	21,095,925	2,832,379	-86.6%
Soldotna	7,952,297	37,296,926	11,509,360	23,194,400	13,762,923	19,493,181	41.6%
Total	43,606,177	84,041,457	44,733,803	80,230,660	71,656,850	92,362,635	28.9%
Annual Change		92.7%	-46.8%	79.4%	-10.7%	28.9%	

Table 1.43

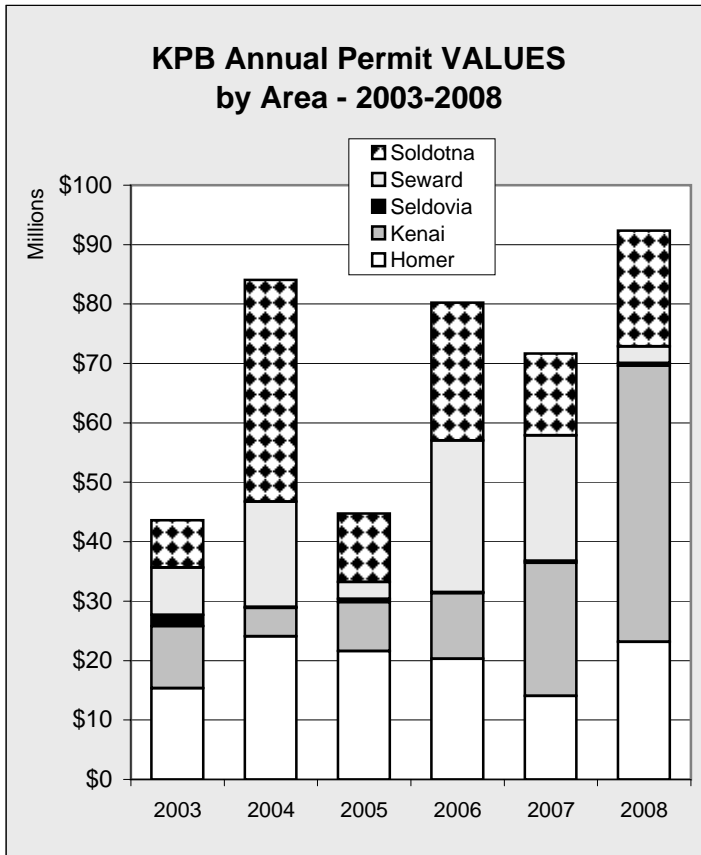

Chart 1.29

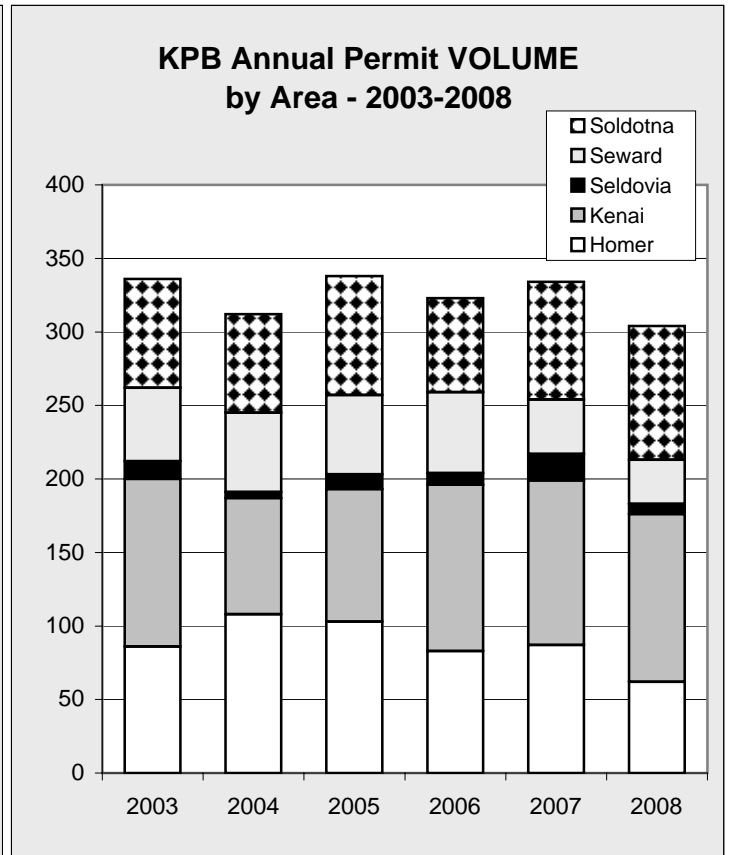

Chart 1.30

KPB Annual Permit VOLUME by Area - 2003 - 2008							
	2003	2004	2005	2006	2007	2008	Annual Change
Homer	86	108	103	83	87	62	-28.7%
Kenai	114	79	90	113	112	114	1.8%
Seldovia	12	4	10	8	18	7	-61.1%
Seward	50	54	54	55	37	30	-18.9%
Soldotna	74	67	81	64	80	91	13.8%
Total	336	312	338	323	334	304	-9.0%
Annual Change		-7.1%	8.3%	-4.4%	3.4%	-9.0%	

Table 1.44

KPB Construction Permits

KPB Annual Permit VALUES by Type - 2003-2008 - in \$							
	2003	2004	2005	2006	2007	2008	Annual Change
Residential New	15,729,888	15,935,344	17,749,648	26,277,740	22,612,367	21,563,338	-4.6%
Residential Alter/Add	2,280,779	2,880,284	2,235,128	2,070,180	4,106,440	2,728,588	-33.6%
Commercial New	15,820,201	56,079,343	19,217,548	44,002,152	33,951,168	61,078,166	79.9%
Commercial Alter/Add	9,775,309	9,146,486	5,531,479	7,880,588	10,986,875	6,992,543	-36.4%
Total	43,606,177	84,041,457	44,733,803	80,230,660	71,656,850	92,362,635	28.9%
Annual Change		92.7%	-46.8%	79.4%	-10.7%	28.9%	

Table 1.45

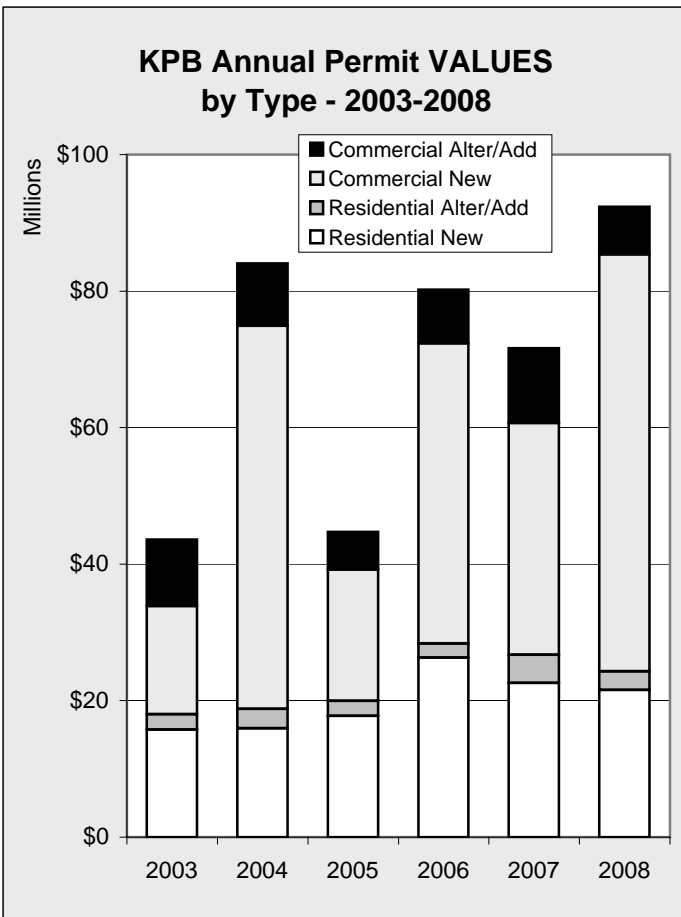

Chart 1.31

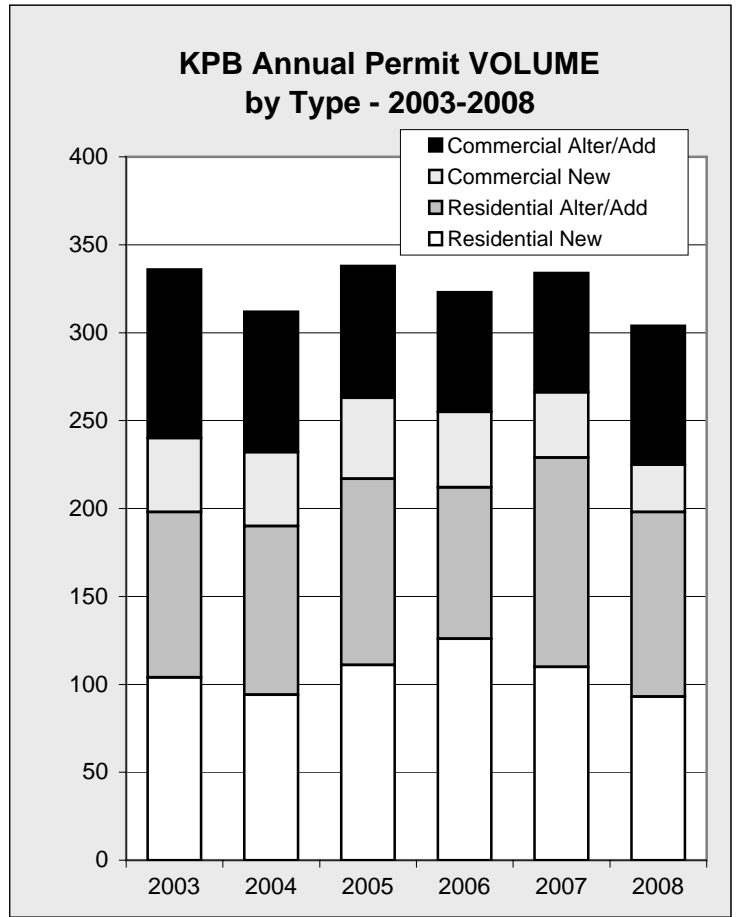

Chart 1.32

KPB Annual Permit VOLUME by Type - 2003-2008							
	2003	2004	2005	2006	2007	2008	Annual Change
Residential New	104	94	111	126	110	93	-15.5%
Residential Alter/Add	94	96	106	86	119	105	-11.8%
Commercial New	42	42	46	43	37	27	-27.0%
Commercial Alter/Add	96	80	75	68	68	79	16.2%
Total	336	312	338	323	334	304	-9.0%
Annual Change		-7.1%	8.3%	-4.4%	3.4%	-9.0%	

Table 1.46

KPB Construction Permits

KPB Annual Permit VALUE by AREA by Quarter - 2003-2008 - in \$					
	1st Quarter	2nd Quarter	3rd Quarter	4th Quarter	TOTAL
2003					
Homer	1,334,340	7,929,500	3,020,075	3,042,900	15,326,815
Kenai	1,557,600	2,728,350	3,700,350	2,455,500	10,441,800
Seldovia	31,000	0	1,835,000	36,500	1,902,500
Seward	1,905,355	3,672,010	1,832,900	572,500	7,982,765
Soldotna	427,018	4,233,924	2,418,310	873,045	7,952,297
TOTAL	5,255,313	18,563,784	12,806,635	6,980,445	43,606,177
2004					
Homer	3,714,020	7,433,711	9,531,900	3,391,000	24,070,631
Kenai	312,000	1,897,400	1,991,750	585,400	4,786,550
Seldovia	20,000	156,200	0	0	176,200
Seward	7,741,600	7,443,900	2,266,300	259,350	17,711,150
Soldotna	5,064,323	3,748,573	23,780,115	4,703,915	37,296,926
TOTAL	16,851,943	20,679,784	37,570,065	8,939,665	84,041,457
2005					
Homer	3,105,900	11,246,000	4,282,500	2,977,000	21,611,400
Kenai	425,500	2,557,300	4,035,100	1,220,000	8,237,900
Seldovia	15,000	466,000	30,500	500	512,000
Seward	1,172,300	758,540	825,446	106,857	2,863,143
Soldotna	1,421,555	6,832,235	3,085,730	169,840	11,509,360
TOTAL	6,140,255	21,860,075	12,259,276	4,474,197	44,733,803
2006					
Homer	3,271,000	7,467,100	6,994,757	2,555,000	20,287,857
Kenai	763,500	4,157,100	4,367,654	1,787,900	11,076,154
Seldovia	30,000	87,000	0	18,000	135,000
Seward	622,217	2,184,672	20,786,060	1,944,300	25,537,249
Soldotna	2,116,441	7,231,328	13,213,749	632,882	23,194,400
TOTAL	6,803,158	21,127,200	45,362,220	6,938,082	80,230,660
2007					
Homer	55,001	7,292,001	5,087,200	1,622,000	14,056,202
Kenai	769,500	6,168,100	15,020,700	439,700	22,398,000
Seldovia	15,000	267,000	60,800	1,000	343,800
Seward	803,238	1,888,287	264,900	18,139,500	21,095,925
Soldotna	827,771	7,877,205	2,765,902	2,292,045	13,762,923
TOTAL	2,470,510	23,492,593	23,199,502	22,494,245	71,656,850
2008					
Homer	1,223,000	16,651,000	2,410,200	2,884,000	23,168,200
Kenai	1,063,300	18,980,900	24,976,300	1,465,875	46,486,375
Seldovia	12,000	7,500	353,000	10,000	382,500
Seward	409,415	1,844,464	216,500	362,000	2,832,379
Soldotna	2,306,253	5,212,121	11,710,661	264,146	19,493,181
TOTAL	5,013,968	42,695,985	39,666,661	4,986,021	92,362,635

Table 1.47

KPB Construction Permits

KPB Annual Permit VALUE by TYPE by Quarter - 2003-2008 - in \$					
	1st Quarter	2nd Quarter	3rd Quarter	4th Quarter	TOTAL
2003					
Residential New	1,097,800	7,868,834	4,209,163	2,554,091	15,729,888
Residential Alter/Add	393,867	984,340	611,572	291,000	2,280,779
Commercial New	72,000	8,965,210	4,636,000	2,146,991	15,820,201
Commercial Alter/Add	3,691,646	745,400	3,349,900	1,988,363	9,775,309
TOTAL	5,255,313	18,563,784	12,806,635	6,980,445	43,606,177
2004					
Residential New	3,456,797	6,374,487	4,950,200	1,153,860	15,935,344
Residential Alter/Add	261,520	483,839	1,605,471	529,454	2,880,284
Commercial New	12,880,026	11,147,815	28,989,901	3,061,601	56,079,343
Commercial Alter/Add	253,600	2,673,643	2,024,493	4,194,750	9,146,486
TOTAL	16,851,943	20,679,784	37,570,065	8,939,665	84,041,457
2005					
Residential New	3,338,356	7,560,499	4,843,170	2,007,623	17,749,648
Residential Alter/Add	415,930	812,470	805,771	200,957	2,235,128
Commercial New	309,000	11,897,148	4,848,400	2,163,000	19,217,548
Commercial Alter/Add	2,076,969	1,589,958	1,761,935	102,617	5,531,479
TOTAL	6,140,255	21,860,075	12,259,276	4,474,197	44,733,803
2006					
Residential New	2,257,031	10,219,599	11,744,277	2,056,833	26,277,740
Residential Alter/Add	45,000	830,630	887,191	307,359	2,070,180
Commercial New	938,410	8,135,648	30,656,794	4,271,300	44,002,152
Commercial Alter/Add	3,562,717	1,941,323	2,073,958	302,590	7,880,588
TOTAL	6,803,158	21,127,200	45,362,220	6,938,082	80,230,660
2007					
Residential New	1,117,722	15,032,392	5,529,253	933,000	22,612,367
Residential Alter/Add	308,549	1,456,488	1,465,038	876,365	4,106,440
Commercial New	208,513	4,437,143	9,350,400	19,955,112	33,951,168
Commercial Alter/Add	835,726	2,566,570	6,854,811	729,768	10,986,875
TOTAL	2,470,510	23,492,593	23,199,502	22,494,245	71,656,850
2008					
Residential New	1,642,277	13,893,346	4,398,840	1,628,875	21,563,338
Residential Alter/Add	204,711	777,639	894,238	852,000	2,728,588
Commercial New	1,464,737	25,579,000	33,113,283	921,146	61,078,166
Commercial Alter/Add	1,702,243	2,446,000	1,260,300	1,584,000	6,992,543
TOTAL	5,013,968	42,695,985	39,666,661	4,986,021	92,362,635

Table 1.48

KPB Construction Permits

KPB Annual Permit VOLUME by AREA by Quarter - 2003-2008					
	1st Quarter	2nd Quarter	3rd Quarter	4th Quarter	TOTAL
2003					
Homer	18	34	21	13	86
Kenai	8	40	45	21	114
Seldovia	3	0	5	4	12
Seward	11	13	15	11	50
Soldotna	6	36	19	13	74
TOTAL	46	123	105	62	336
2004					
Homer	16	26	42	24	108
Kenai	4	30	31	14	79
Seldovia	1	3	0	0	4
Seward	7	21	19	7	54
Soldotna	9	26	24	8	67
TOTAL	37	106	116	53	312
2005					
Homer	18	47	27	11	103
Kenai	10	33	33	14	90
Seldovia	1	6	2	1	10
Seward	12	19	16	7	54
Soldotna	16	40	20	5	81
TOTAL	57	145	98	38	338
2006					
Homer	14	39	25	5	83
Kenai	14	42	43	14	113
Seldovia	1	6	0	1	8
Seward	7	23	19	6	55
Soldotna	5	25	27	7	64
TOTAL	41	135	114	33	323
2007					
Homer	3	40	28	16	87
Kenai	11	43	44	14	112
Seldovia	1	9	7	1	18
Seward	7	11	10	9	37
Soldotna	9	33	22	16	80
TOTAL	31	136	111	56	334
2008					
Homer	7	31	13	11	62
Kenai	12	45	42	15	114
Seldovia	1	2	3	1	7
Seward	5	12	4	9	30
Soldotna	21	37	28	5	91
TOTAL	46	127	90	41	304

Table 1.49

KPB Construction Permits

KPB Annual Permit VOLUME by TYPE by Quarter - 2003-2008					
	1st Quarter	2nd Quarter	3rd Quarter	4th Quarter	TOTAL
2003					
Residential New	7	47	28	22	104
Residential Alter/Add	17	33	34	10	94
Commercial New	1	17	17	7	42
Commercial Alter/Add	21	26	26	23	96
TOTAL	46	123	105	62	336
2004					
Residential New	17	34	32	11	94
Residential Alter/Add	5	30	44	17	96
Commercial New	7	11	15	9	42
Commercial Alter/Add	8	31	25	16	80
TOTAL	37	106	116	53	312
2005					
Residential New	18	49	31	13	111
Residential Alter/Add	14	46	36	10	106
Commercial New	6	27	9	4	46
Commercial Alter/Add	19	23	22	11	75
TOTAL	57	145	98	38	338
2006					
Residential New	13	57	48	8	126
Residential Alter/Add	5	40	32	9	86
Commercial New	5	22	9	7	43
Commercial Alter/Add	18	16	25	9	68
TOTAL	41	135	114	33	323
2007					
Residential New	8	59	36	7	110
Residential Alter/Add	8	34	51	26	119
Commercial New	2	17	10	8	37
Commercial Alter/Add	13	26	14	15	68
TOTAL	31	136	111	56	334
2008					
Residential New	8	56	19	10	93
Residential Alter/Add	10	37	44	14	105
Commercial New	5	8	10	4	27
Commercial Alter/Add	23	26	17	13	79
TOTAL	46	127	90	41	304

Table 1.50

KPB Unemployment Statistics

Unemployment data are developed through a survey by Alaska Department of Labor and Workforce Development (AK DOLWD) which are entered into a standardized model used throughout the United States. Calculations are presented for four categories of worker. The estimated total labor force include all residents willing and able to work, whether or not they are employed. Employment estimates include all persons who are gainfully employed by establishments that meet requirements for reporting of wages. Unemployment is calculated by subtracting the number of gainfully employed persons from the estimated total labor force. Lastly, the unemployment rate is calculated by dividing the number of unemployed persons by the estimated total labor force.

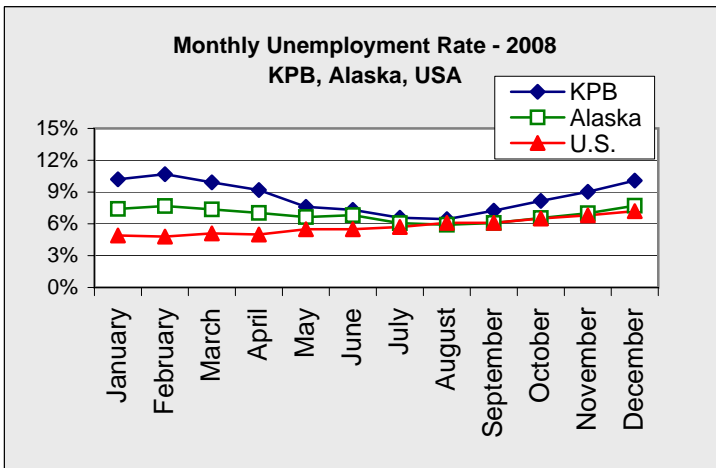

The chart to the left identifies the relationship between unemployment rates of the U.S., Alaska, and the KP. Typically, the annual high unemployment rate is reached during first quarter. Also, generally, the U.S. rate is the lowest, followed by Alaska, with the KP having the highest rate in this survey driven data set.

Chart 1.33

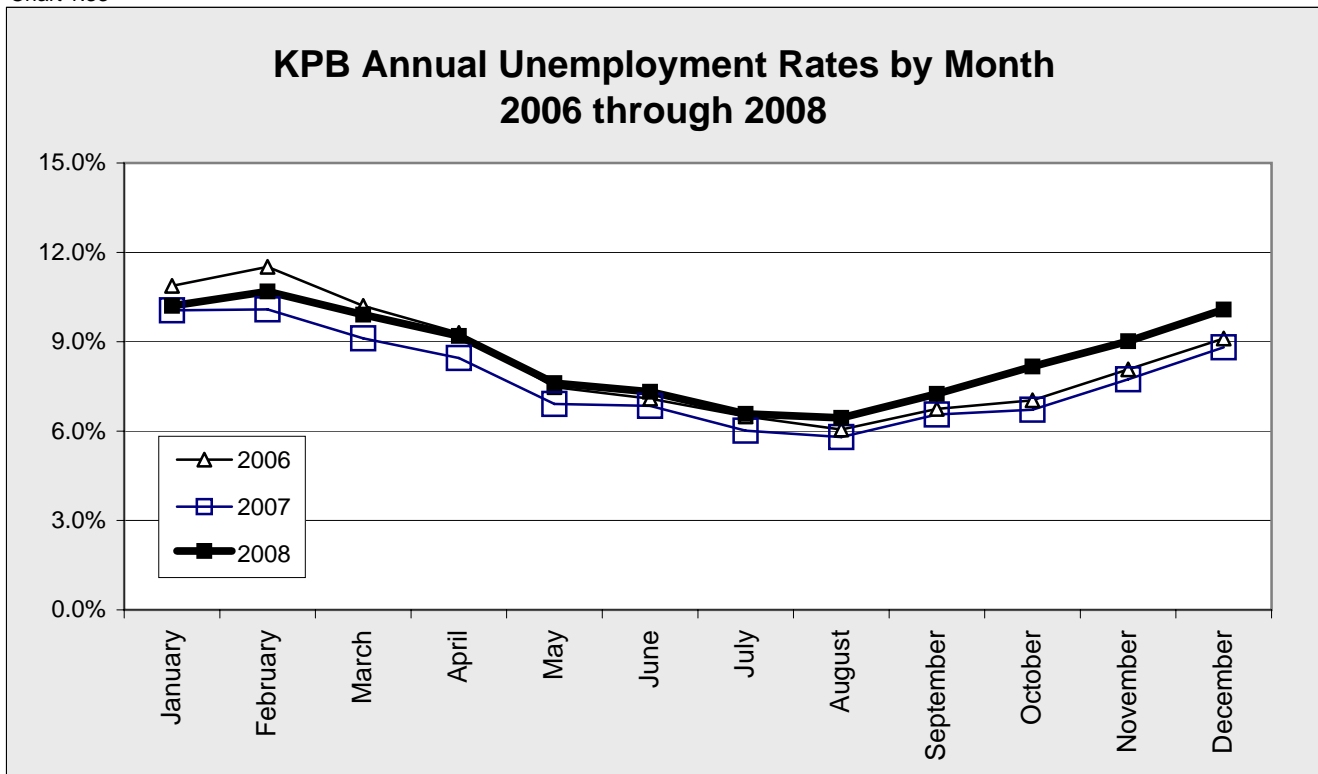

Chart 1.34

KPB Unemployment Statistics

KPB Labor Force by Month - 2000-2008													
	Jan	Feb	Mar	Apr	May	Jun	Jul	Aug	Sep	Oct	Nov	Dec	Avg
2000	23,011	23,329	23,290	23,365	24,542	26,598	26,448	26,243	25,160	24,101	24,071	24,174	24,528
2001	23,056	23,003	23,055	23,139	24,195	26,114	26,836	25,619	24,496	23,717	23,656	23,801	24,224
2002	23,659	23,374	23,569	24,173	24,925	25,919	26,796	26,125	24,942	24,317	24,294	24,409	24,709
2003	24,298	24,108	24,243	24,379	25,394	26,781	27,170	26,352	24,571	24,028	23,988	23,875	24,932
2004	23,874	24,000	24,130	24,130	25,302	27,119	27,599	26,342	24,958	24,334	24,116	23,981	24,990
2005	23,977	23,941	24,094	24,081	25,254	26,855	27,547	26,324	24,873	24,309	23,952	23,897	24,925
2006	24,261	24,422	24,254	24,457	25,770	27,205	27,625	27,383	25,518	24,741	24,605	24,773	25,418
2007	24,572	24,659	24,675	24,672	25,907	27,657	28,169	27,646	25,996	24,970	24,923	25,026	25,739
2008	24,640	24,888	25,357	25,374	26,786	28,189	28,344	28,080	26,441	25,626	25,470	25,689	26,240

Table 1.51

KPB Unemployment by Month - 2000-2008													
	Jan	Feb	Mar	Apr	May	Jun	Jul	Aug	Sep	Oct	Nov	Dec	Avg
2000	2,530	2,575	2,445	2,138	1,943	1,843	1,546	1,556	1,496	1,671	1,871	2,019	1,969
2001	2,327	2,379	2,276	2,045	1,767	1,813	1,543	1,560	1,560	1,754	1,965	2,181	1,931
2002	2,503	2,518	2,542	2,335	2,117	2,207	1,981	2,007	2,092	2,247	2,466	2,690	2,309
2003	2,935	3,048	2,795	2,564	2,345	2,542	2,169	2,122	2,126	2,301	2,508	2,636	2,508
2004	2,956	2,969	2,897	2,508	2,272	2,419	2,033	1,956	1,971	2,129	2,309	2,429	2,404
2005	2,625	2,774	2,493	2,231	1,942	2,015	1,773	1,737	1,809	1,921	2,092	2,249	2,138
2006	2,638	2,812	2,475	2,273	1,926	1,929	1,794	1,658	1,721	1,740	1,986	2,256	2,101
2007	2,470	2,487	2,249	2,085	1,791	1,894	1,694	1,603	1,704	1,677	1,929	2,206	1,982
2008	2,514	2,660	2,513	2,333	2,038	2,063	1,865	1,810	1,917	2,093	2,297	2,589	2,412

Table 1.52

KPB Unemployment Rate by Month - 2000-2008													
	Jan	Feb	Mar	Apr	May	Jun	Jul	Aug	Sep	Oct	Nov	Dec	Avg
2000	11.0%	11.0%	10.5%	9.2%	7.9%	6.9%	5.8%	5.9%	5.9%	6.9%	7.8%	8.4%	8.1%
2001	10.1%	10.3%	9.9%	8.8%	7.3%	6.9%	5.7%	6.1%	6.4%	7.4%	8.3%	9.2%	8.0%
2002	10.6%	10.8%	10.8%	9.7%	8.5%	8.5%	7.4%	7.7%	8.4%	9.2%	10.2%	11.0%	9.4%
2003	12.1%	12.6%	11.5%	10.5%	9.2%	9.5%	8.0%	8.1%	8.7%	9.6%	10.5%	11.0%	10.1%
2004	12.4%	12.4%	12.0%	10.4%	9.0%	8.9%	7.4%	7.4%	7.9%	8.7%	9.6%	10.1%	9.7%
2005	10.9%	11.6%	10.3%	9.3%	7.7%	7.5%	6.4%	6.6%	7.3%	7.9%	8.7%	9.4%	8.6%
2006	10.9%	11.5%	10.2%	9.3%	7.5%	7.1%	6.5%	6.1%	6.7%	7.0%	8.1%	9.1%	8.3%
2007	10.1%	10.1%	9.1%	8.5%	6.9%	6.8%	6.0%	5.8%	6.6%	6.7%	7.7%	8.8%	7.8%
2008	10.2%	10.7%	9.9%	9.2%	7.6%	7.3%	6.6%	6.4%	7.3%	8.2%	9.0%	10.1%	9.5%

Table 1.53

KPB Employment Rate by Month - 2000-2008													
	Jan	Feb	Mar	Apr	May	Jun	Jul	Aug	Sep	Oct	Nov	Dec	Avg
2000	20,481	20,754	20,845	21,227	22,599	24,755	24,902	24,687	23,664	22,430	22,200	22,155	22,558
2001	20,729	20,624	20,779	21,094	22,428	24,301	25,293	24,059	22,936	21,963	21,691	21,620	22,293
2002	21,156	20,856	21,027	21,838	22,808	23,712	24,815	24,118	22,850	22,070	21,828	21,719	22,400
2003	21,363	21,060	21,448	21,815	23,049	24,239	25,001	24,230	22,445	21,727	21,480	21,239	22,425
2004	20,918	21,031	21,233	21,622	23,030	24,700	25,566	24,386	22,987	22,205	21,807	21,552	22,586
2005	21,352	21,167	21,601	21,850	23,312	24,840	25,774	24,587	23,064	22,388	21,860	21,648	22,787
2006	21,623	21,610	21,779	22,184	23,844	25,276	25,831	25,725	23,797	23,001	22,619	22,517	23,317
2007	22,102	22,172	22,426	22,587	24,116	25,763	26,475	26,043	24,292	23,293	22,994	22,820	23,757
2008	22,126	22,228	22,844	23,041	24,748	26,126	26,479	26,270	24,524	23,533	23,173	23,100	24,016

Table 1.54

KPB Demographics

Census 2000

KPB population counts are conducted by the United States Census Bureau every ten years. Check out their website (<http://www.census.gov/>), which has two excellent data options - QuickFacts and AmericanFactFinder.

Census data is collected for two general types of area: incorporated cities and Census Designated Places (CDP). KPB incorporated cities include Homer, Kachemak City, Kenai, Seldovia, Seward and Soldotna. A CDP is delineated by geographic features such as rivers, roads, or ridges. Defining characteristics include:

- * A sense of community;
- * A population of 25 or more; and
- * It must have been recognized as possibly fitting the criteria four years prior to the census, as planning began.

The Census Bureau considers an incorporated city with a population greater than 2,500 to be urban, of which there are four in the KPB: Homer, Kenai, Seward and Soldotna. Kenai is ranked as the 6th largest city in Alaska, Homer ranks 14th, and Soldotna is the 15th largest as of Census 2000 .

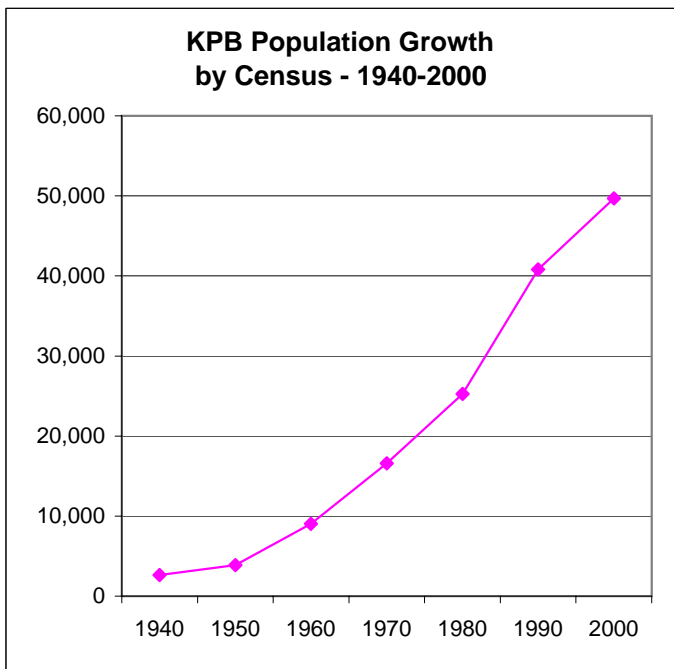

Chart 1.35

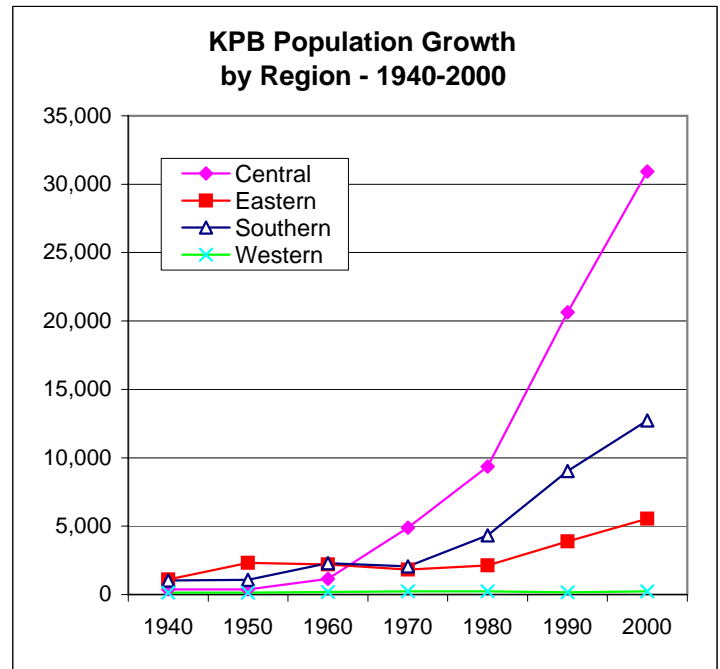

Chart 1.36

Population Estimates

The AK DOLWD prepares annual population estimates for Alaska. Estimates include Armed Forces members serving in Alaska but exclude seasonal populations. Primary indicators for population change include Alaska Permanent Fund Dividend applications, vital statistics, and survey information. Although estimates are identified for July 1, data represents annual average resident population rather than a specific date.

These revised, current estimates are consistent with U.S. Census Bureau statewide total population estimates and supersede all previously published estimates.

<http://almis.labor.state.ak.us/?PAGEID=67&SUBID=171>

KPB Demographics

KPB CDP's - Census 2000, Population Estimates - 2001- 2007 (Revised-5/6/08)									
KPB Community	2000 Census	June 1 Estimate (Subject to Annual Revision)							Annual Change
		2001	2002	2003	2004	2005	2006	2007	
Anchor Point	1,845	1,809	1,780	1,809	1,829	1,753	1,803	1,814	0.6%
Bear Creek	1,748	1,836	1,833	1,829	1,904	1,898	1,922	1,945	1.2%
Beluga	32	24	25	27	26	21	21	19	-9.5%
Clam Gulch	173	168	173	176	163	171	165	175	6.1%
Cohoe	1,168	1,175	1,211	1,208	1,321	1,282	1,260	1,263	0.2%
Cooper Landing	369	389	370	351	345	343	357	353	-1.1%
Crown Point	75	89	88	82	90	82	81	74	-8.6%
Diamond Ridge*	1,802	1,835	412	314	769	743	690	733	6.2%
Fox River	616	594	576	582	613	627	639	643	0.6%
Fritz Creek	1,603	1,663	1,733	1,742	1,731	1,761	1,723	1,757	2.0%
Funny River	636	624	687	707	736	746	729	747	2.5%
Halibut Cove	35	29	28	27	26	23	24	20	-16.7%
Happy Valley	489	505	521	505	528	483	472	495	4.9%
Homer*	3,946	4,070	5,535	5,877	5,350	5,394	5,454	5,502	0.9%
Hope	137	145	152	161	165	141	143	147	2.8%
Kachemak	431	426	433	478	470	460	458	467	2.0%
Kalifornsky	5,846	6,017	6,159	6,248	6,638	6,825	6,914	7,129	3.1%
Kasilof	471	452	501	559	473	509	547	596	9.0%
Kenai	6,942	6,889	7,076	7,129	6,839	6,768	6,864	6,971	1.6%
Lowell Point	92	96	108	89	76	96	76	85	11.8%
Miller Landing*	74	70	Annexed into Homer						
Moose Pass	206	206	217	219	220	217	204	201	-1.5%
Nanwalek	177	184	219	214	204	219	228	217	-4.8%
Nikiski	4,327	4,363	4,362	4,351	4,289	4,190	4,179	4,345	4.0%
Nikolaevsk	345	345	334	315	309	305	297	297	0.0%
Ninilchik	772	760	762	774	786	786	784	778	-0.8%
Port Graham	171	178	174	165	153	128	136	134	-1.5%
Primrose	93	99	92	87	91	84	79	78	-1.3%
Ridgeway	1,932	1,962	1,968	2,020	2,058	2,060	1,961	1,987	1.3%
Salamatof	954	912	915	923	920	911	906	878	-3.1%
Seldovia**	430	435	449	430	423	390	379	445	17.4%
Seldovia City**	286	287	288	279	264	240	220	284	29.1%
Seldovia Village**	144	148	161	151	159	150	159	161	1.3%
Seward	2,830	2,759	2,755	2,744	2,542	2,595	2,627	2,661	1.3%
Soldotna	3,759	3,793	3,851	4,001	3,776	3,794	3,807	3,982	4.6%
Sterling	4,705	4,756	4,780	4,878	4,919	4,980	5,036	5,123	1.7%
Sunrise	18	16	14	15	19	24	22	20	-9.1%
Tyonek	193	161	181	192	185	199	199	181	-9.0%
Kenai/Cook Inlet remainder area		229	187	195	189	168	153	118	-22.9%
Seward census sub area		23	13	23	18	15	11	6	-45.5%
Remainder of KPB Borough	249								
	49,691	50,086	50,674	51,446	51,193	51,191	51,350	52,407	2.1%

Table 1.55

* - Homer annexation included all of Miller Landing CDP and part of Diamond Ridge CDP. Annexation was effective April 1, 2002.

** - Seldovia City plus Seldovia Village is not equal to the Seldovia CDP.

Note - All Estimates since 2000 have been revised by the State of Alaska Department of Labor and Workforce Development.

Source - <http://www.labor.state.ak.us/research/pop/estimates/04t4-3.xls>

KPB Demographics

KPB Census by City/CDP - 1940-2000									
KPB Community	Region	1940	1950	1960	1970	1980	1990	2000	
Anchor Point	S	20	65	171	102	226	866	1,845	
Bear Creek	E	0	0	0	0	0	580	1,748	
Beluga	W	New CDP - Census 2000							32
Clam Gulch	C	0	0	0	47	50	79	173	
Cohoe	C	0	0	122	0	0	508	1,168	
Cooper Landing	E	0	60	88	31	116	243	369	
Crown Point	E	0	0	0	0	0	62	75	
Diamond Ridge	S	New CDP - Census 2000							1,802
Fox River	S	0	0	0	0	0	382	616	
Fritz Creek	S	0	0	0	27	302	1,426	1,603	
Funny River	C	New CDP - Census 2000							636
Halibut Cove	S	0	0	25	44	47	78	35	
Happy Valley	S	0	0	0	0	0	309	489	
Homer	S	325	307	1,247	1,083	2,209	3,660	3,946	
Hope	E	71	63	44	51	103	161	137	
Jakalof Bay	S	New CDP - 1980, Deleted - Census 2000					36	28	Deleted
Kachemak	S	0	0	0	76	403	365	431	
Kalifornsky	C	0	0	0	0	92	285	5,846	
Kasilof	C	62	62	89	71	201	383	471	
Kenai	C	303	321	778	3,533	4,324	6,327	6,942	
Lowell Point	E	New CDP - Census 2000							92
Miller Landing	S	New CDP - Census 2000							74
Moose Pass	E	84	70	136	53	76	81	206	
Nanwalek	S	48	75	78	58	124	158	177	
Nikiski	C		0	0	0	1,109	2,743	4,327	
Nikolaevsk	S	0	0	0	0	0	371	345	
Ninilchik	S	132	97	169	134	341	456	772	
Port Graham	S	93	92	139	107	161	166	171	
Primrose	E	0	0	0	0	0	63	93	
Ridgeway	C	0	0	0	0	0	2,018	1,932	
Salamatof	C	0	0	0	0	334	999	954	
Seldovia City	S	410	437	460	437	479	316	286	
Seward	E	949	2,114	1,891	1,587	1,843	2,699	2,830	
Soldotna	C	0	0	32	1,202	2,320	3,482	3,759	
Sterling	C	0	0	115	30	919	3,802	4,705	
Sunrise	C	New CDP - Census 2000							18
Tyonek	W	136	132	187	232	239	154	193	
Remainder of census area	E		946	3,282	7,681	16,116	7,409	249	
Kenai Peninsula Borough		2,633	4,831	9,053	16,586	25,282	40,802	49,691	

Table 1.56

KPB Demographics

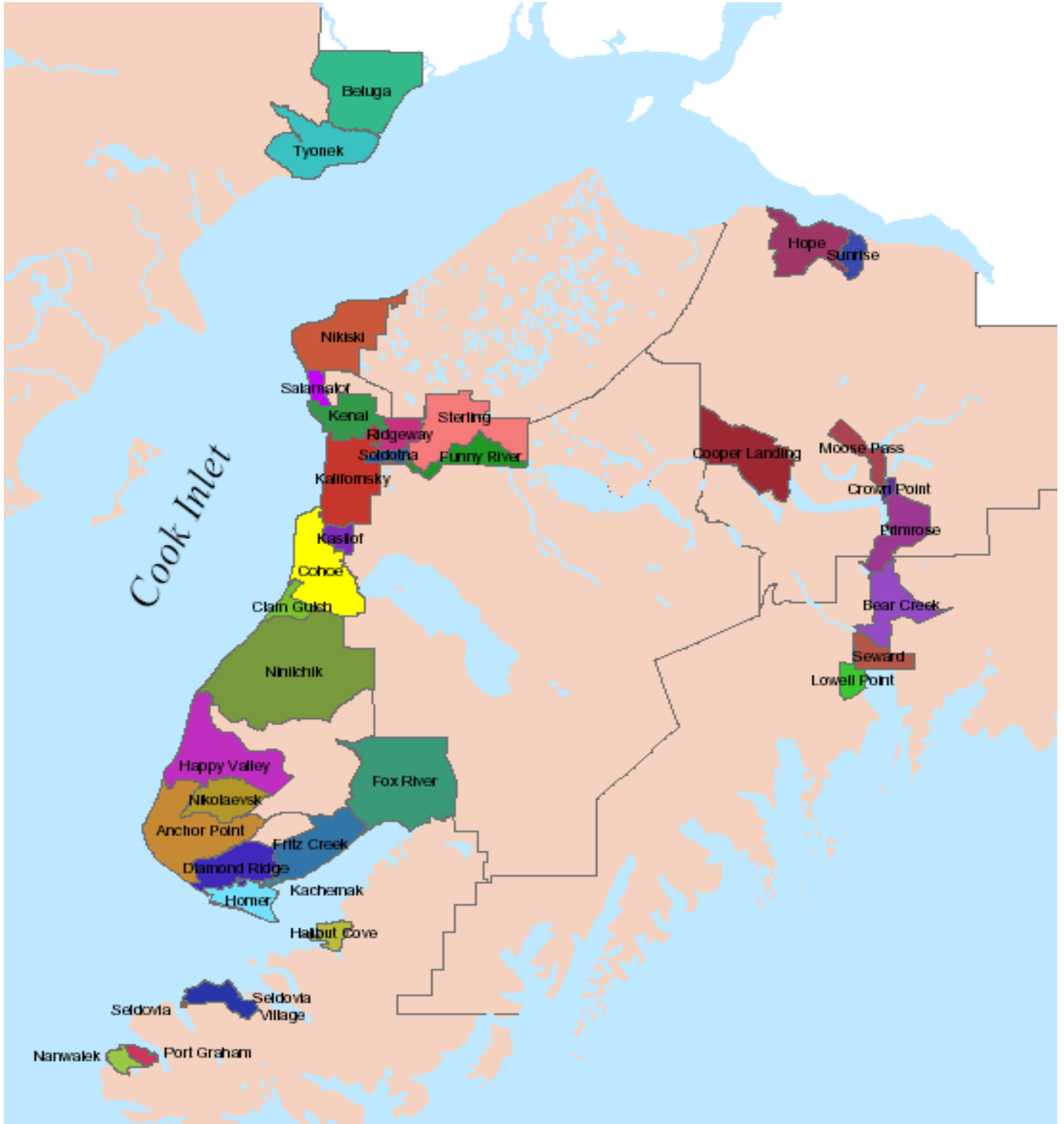

KENAI PENINSULA BOROUGH CENSUS DESIGNATED PLACES

Chart 1.37

KPB Demographics

KPB Population by Age Group - 1990 v 2000 v 2007

	1990	2000	2007	Percent Change-2000, 2007	Percent of Total 2007 Population
Total Population	40,802	49,691	52,370	5.4%	100.00%
Under 5 years	3,862	3,288	3,356	2.1%	6.3%
5 to 9 years	4,059	4,024	3,604	-10.4%	7.7%
10 to 14 years	3,516	4,698	3,873	-17.6%	9.0%
15 to 19 years	2,970	4,140	4,297	3.8%	7.9%
20 to 24 years	2,081	2,132	2,985	40.0%	4.1%
25 to 34 years	7,348	5,648	5,443	-3.6%	10.8%
35 to 44 years	8,234	9,074	6,906	-23.9%	17.3%
45 to 54 years	4,205	8,739	9,802	12.2%	16.7%
55 to 59 years	1,376	2,632	4,117	56.4%	5.0%
60 to 64 years	1,164	1,667	2,959	77.5%	3.2%
65 to 74 years	1,489	2,361	3,154	33.6%	4.5%
75 to 84 years	419	1,077	1,421	31.9%	2.1%
85 years and over	79	211	453	114.7%	0.4%

Table 1.57

KPB's median age increased from 31.1 years during 1990 to 36.3 as of Census 2000. Alaska's median age was 32.4 years while the U.S. was 35.3 years, per Census 2000.

The KPB 2007 median age is estimated at 39.1 years, down from the 2006 estimate of 39.7 years.

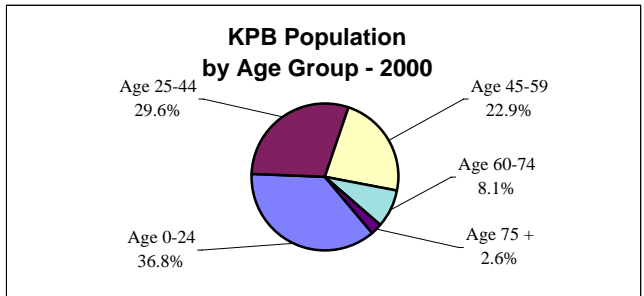

Chart 1.38

KPB Population by Age Group - 1990, 2000, 2007

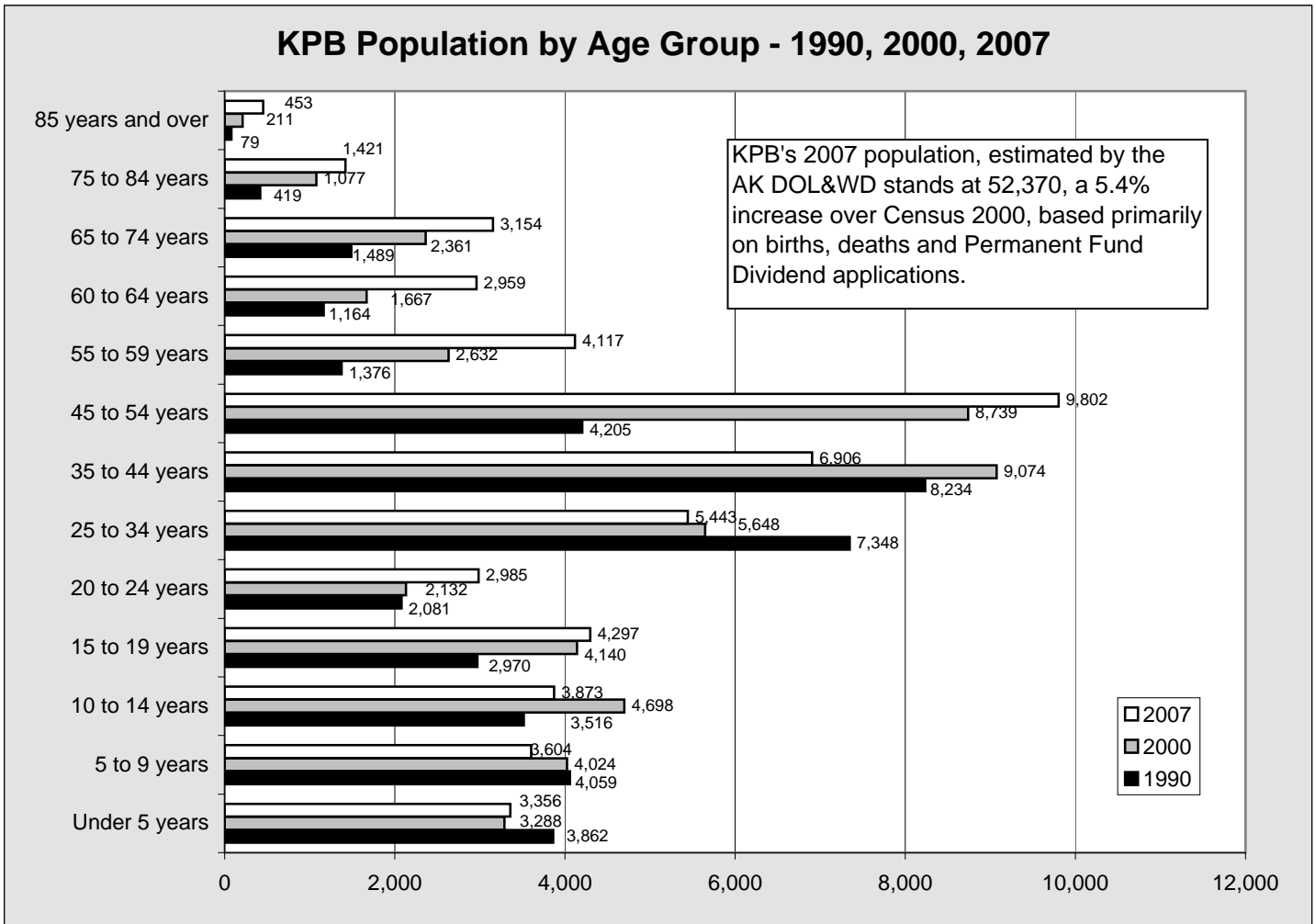

Chart 1.39

KPB Demographics

Percentage Change of Population By Age Cohort - 2000-2007						
Age	Kenai Peninsula Borough	Municipality of Anchorage	Fairbanks Northstar Borough	Juneau Borough	Matanuska-Susitna Borough	State of Alaska
0-4	2.1%	14.2%	20.8%	-0.4%	51.2%	13.2%
5-9	-10.4%	0.7%	5.9%	-16.2%	20.8%	-0.9%
10-14	-17.6%	1.1%	-5.8%	-15.1%	12.6%	-5.0%
15-19	3.8%	13.8%	5.0%	1.4%	31.1%	11.9%
20-24	40.0%	17.2%	-1.1%	5.4%	73.3%	15.9%
25-29	-4.0%	-0.3%	-1.6%	-13.0%	45.6%	-0.4%
30-34	-3.3%	-2.1%	10.1%	-20.7%	29.0%	-2.3%
35-39	-22.7%	-12.3%	-7.0%	-22.0%	7.4%	-14.5%
40-44	-24.9%	-11.8%	-6.8%	-18.2%	-1.6%	-13.4%
45-49	-6.7%	5.0%	5.7%	-9.8%	25.3%	3.1%
50-54	37.5%	25.8%	30.1%	15.0%	73.2%	28.3%
55-59	56.4%	52.1%	69.2%	64.8%	90.5%	54.9%
60-64	77.5%	68.9%	81.2%	64.8%	92.3%	66.6%
65-69	45.8%	38.3%	44.5%	55.0%	60.0%	40.6%
70-74	18.4%	16.7%	19.9%	11.1%	34.0%	16.7%
75-79	17.4%	21.9%	24.9%	5.7%	54.4%	21.0%
80-84	63.3%	51.3%	34.4%	8.1%	92.4%	47.2%
85-90	129.8%	72.0%	64.2%	63.5%	104.3%	65.5%
90+	90.0%	86.0%	105.7%	75.9%	145.8%	87.0%
Overall Change	5.4%	9.0%	9.8%	-1.3%	35.0%	8.0%
Median Age in Years						
2000	36.3	32.4	29.5	35.3	34.1	32.4
2007	39.1	33.1	31.3	38.1	34.4	32.6

Table 1.58

Note that from 2000 to 2007, three of the five boroughs illustrated experienced a population decrease in the 10-14 year age group, while five of five areas experienced population decline in the 35-44 year age group.

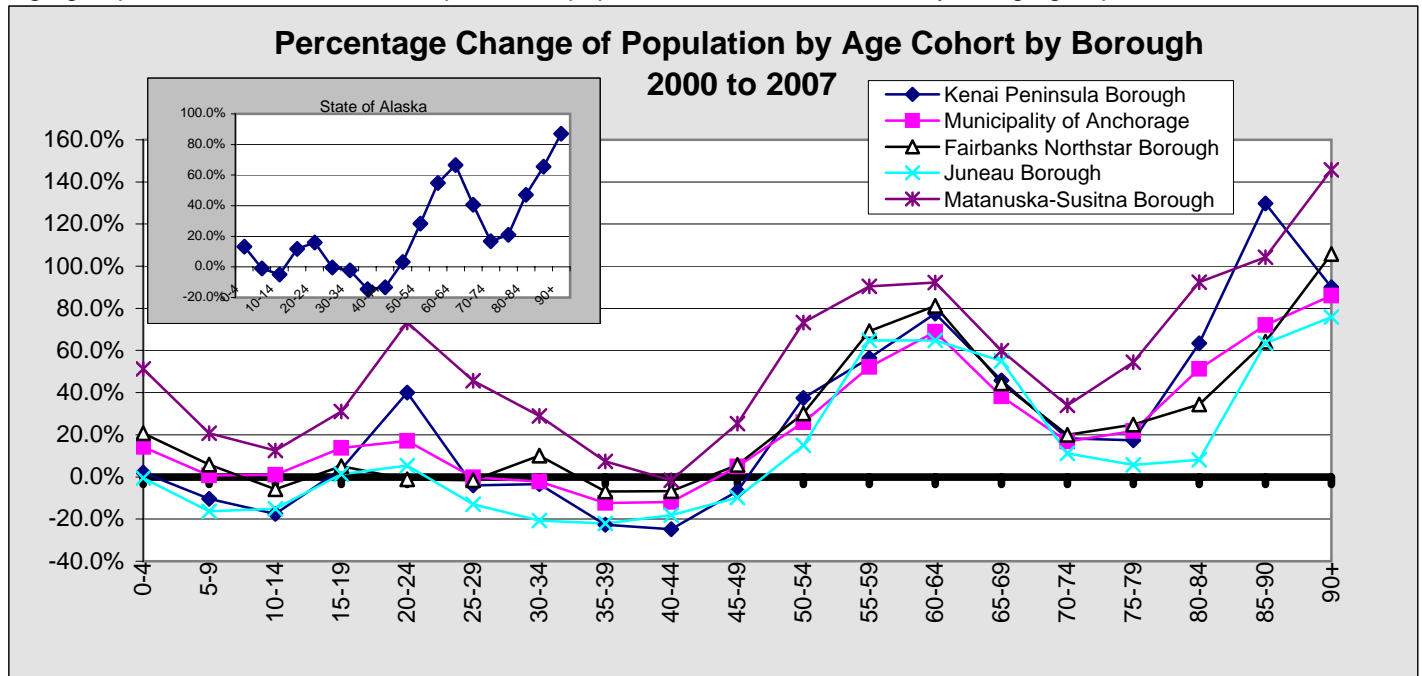

Chart 1.40

Note that Alaska follows the same aging trend. See inset.

KPB Demographics

KPB Select Detail - 1990 v 2000									
Population (2008 estimate - 52,836)					Housing				
	1990	2000	Percent Change	Percent of Total		1990	2000	Percent Change	Percent of Total
Total Population	40,802	49,691	21.8%	100.0%	Total Households	14,250	18,438	29.4%	100.0%
Male	21,606	25,853	19.7%	52.0%	Family Households	10,216	12,716	24.5%	69.0%
Female	19,196	23,838	24.2%	48.0%	With Children Under 18		7,003	NA	38.0%
Under 5 years	3,795	3,288	-13.4%	6.6%	Married Couple Family	8,456	10,218	20.8%	55.4%
5 to 9 years	4,104	4,024	-1.9%	8.1%	With Own Children Under 18		5,133	NA	27.8%
10 to 14 years	3,505	4,698	34.0%	9.5%	Female Householder, no husband present		1,654	NA	9.0%
15 to 19 years	2,939	4,140	40.9%	8.3%	With Own Children Under 18		1,276	NA	6.9%
20 to 24 years	2,086	2,132	2.2%	4.3%	Average Household Size	2.79	2.62	-6.1%	0.0%
25 to 34 years	7,281	5,648	-22.4%	11.4%	Average Family Size		3.15	NA	0.0%
35 to 44 years	8,229	9,074	10.3%	18.3%	Total Housing Units	19,364	24,871	NA	100.0%
45 to 54 years	4,280	8,739	104.2%	17.6%	Occupied Housing Units	14,250	18,438	29.4%	74.1%
55 to 59 years	1,387	2,632	89.8%	5.3%	Vacant Housing Units	5,114	6,433	25.8%	25.9%
60 to 64 years	1,181	1,667	41.2%	3.4%	Seasonal, Recreational, Occasional Use	2,819	4,560	61.8%	18.3%
65 to 74 years	1,503	2,361	57.1%	4.8%	Owner Vacancy Rate	4.1%	2.9%	NA	NA
75 to 84 years	431	1,077	149.9%	2.2%	Rental Vacancy Rate	13.9%	14.4%	NA	NA
85 years and over	81	211	160.5%	0.4%	Owner Occupied Units	9,677	13,585	40.4%	54.6%
Median Age	31.1	36.3	16.7%	NA	Renter Occupied Units	4,573	4,853	6.1%	19.5%
18 Years and Over	13,396	34,832	160.0%	70.1%	Marital Status (over 15)		37,696	NA	100.0%
Male		18,239	NA	NA	Never married		8,829	NA	23.4%
Female		16,593	NA	NA	Married except separated		22,022	NA	58.4%
65 Years and Over	2,015	3,649	81.1%	7.3%	Separated		698	NA	1.9%
Male		1,765	NA	NA	Widowed		1,330	NA	3.5%
Female		1,884	NA	NA	Divorced		4,817	NA	12.8%
Place of Birth					Disabled, Noninstitutionalized				
U.S. Native	39,726	48,335	21.7%	97.3%	Population 5 to 20		13,244	NA	100.0%
Born in Alaska		17,440	NA	35.1%	With a Disability		842	NA	6.4%
Born in other state		30,444	NA	61.3%	Population 21 to 64		28,547	NA	100.0%
Foreign Born	1,076	1,356	26.0%	2.7%	With a Disability		4,843	NA	17.0%
Naturalized Citizen		872	NA	1.8%	Percent Employed		45.4%	NA	45.4%
Not a Citizen		484	NA	1.0%	Without a Disability		23,704	NA	83.0%
Veteran Status					Income in 1999 - Families				
Civilian veterans	5,335	5,941	11.4%	17.1%	Total		12,736		
Educational Attainment					Less than \$10,000	604	602	-0.3%	4.7%
Population 25 years and over				31,388	\$10,000 - \$14,999	548	512	-6.6%	4.0%
Less than 9th grade	934	985	5.5%	3.1%	\$15,000 - \$24,999	1,177	1,248	6.0%	9.8%
9th-12th, no diploma	2,185	2,620	19.9%	8.3%	\$25,000 - \$34,999	1,151	1,396	21.3%	11.0%
High School Diploma	8,560	9,990	16.7%	31.8%	\$35,000 - \$49,999	1,895	1,970	4.0%	15.5%
College, no degree	6,581	9,492	44.2%	30.2%	\$50,000 - \$74,999	2,688	3,148	17.1%	24.7%
Associate Degree	1,789	1,939	8.4%	6.2%	\$75,000 - \$99,999	1,361	1,855	36.3%	14.6%
Bachelor's Degree	3,165	4,254	34.4%	13.6%	\$100,000 - \$149,999	687	1,561	127.2%	12.3%
Graduate, Profess Degr	1,209	2,108	74.4%	6.7%	\$150,000 - \$199,999	279	245	-12.2%	1.9%
Percent HS Grad	87.2%	88.5%	1.5%	NA	\$200,000 or more	NA	199	NA	1.6%
Percent Bachelor's +	17.9%	20.3%	13.4%	NA	Median Income - \$	48,339	54,106	11.9%	NA

Table 1.59

Homer Sales

Homer Fourth Quarter GROSS Sales by Line of Business - 2003-2008 - in \$								
LOB	2003	2004	2005	2006	2007	2008	Annual Percent Change	Annual Amount Change
PROD	235,429	280,153	83,567	75,751	1,448,808	36,904	-97.5%	-1,411,904
SALES	19,819,833	20,347,366	20,719,702	22,753,138	24,953,954	25,920,586	3.9%	966,632
CONST	9,227,618	12,970,385	8,816,526	21,522,671	9,705,513	14,257,323	46.9%	4,551,810
PROP	3,120,675	3,904,069	3,409,384	3,697,020	4,116,943	4,148,184	0.8%	31,241
TOUR	3,594,094	3,705,924	3,558,403	3,772,142	3,814,877	2,179,161	-42.9%	-1,635,716
SERV	5,367,328	5,942,282	6,579,703	7,907,367	8,338,897	8,740,419	4.8%	401,522
PROF	3,049,844	3,712,248	3,082,232	2,936,323	2,817,452	2,808,013	-0.3%	-9,439
UTIL	6,699,963	8,065,919	8,833,640	12,043,125	11,159,304	14,245,759	27.7%	3,086,455
MANU	1,016,444	836,300	1,433,039	1,562,600	1,800,499	1,379,129	-23.4%	-421,370
TRAN	640,338	1,328,055	810,724	1,351,554	3,134,699	4,578,878	46.1%	1,444,179
WHLS	6,813,824	10,762,068	12,405,881	13,849,599	8,832,776	8,927,346	1.1%	94,570
GOV	745,327	749,646	777,246	822,267	885,817	814,123	-8.1%	-71,694
TOTAL	60,330,717	72,604,415	70,510,047	92,293,557	81,009,539	88,035,825	8.7%	7,026,286

Table 2.1

For complete listing of Lines of Business, see page 13

Homer Fourth Quarter GROSS Sales History	
2003	60,330,717
2004	72,604,415
2005	70,510,047
2006	92,293,557
2007	81,009,539
2008	88,035,825

Table 2.2

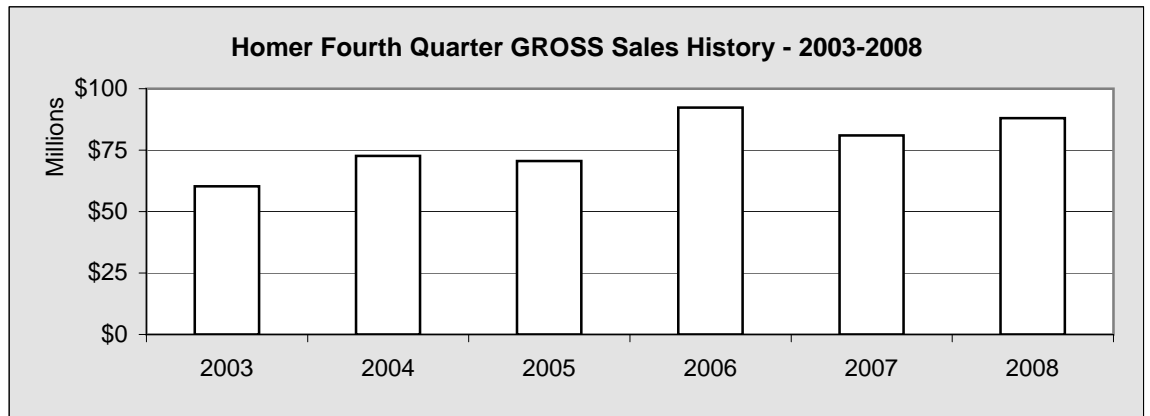

Chart 2.1

Homer Five Year Change Fourth Quarter GROSS Sales		
LOB	2003	2008
PROD	235,429	36,904
SALES	19,819,833	25,920,586
CONST	9,227,618	14,257,323
PROP	3,120,675	4,148,184
TOUR	3,594,094	2,179,161
SERV	5,367,328	8,740,419
PROF	3,049,844	2,808,013
UTIL	6,699,963	14,245,759
MANU	1,016,444	1,379,129
TRAN	640,338	4,578,878
WHLS	6,813,824	8,927,346
GOV	745,327	814,123
TOTAL	60,330,717	88,035,825

Table 2.3

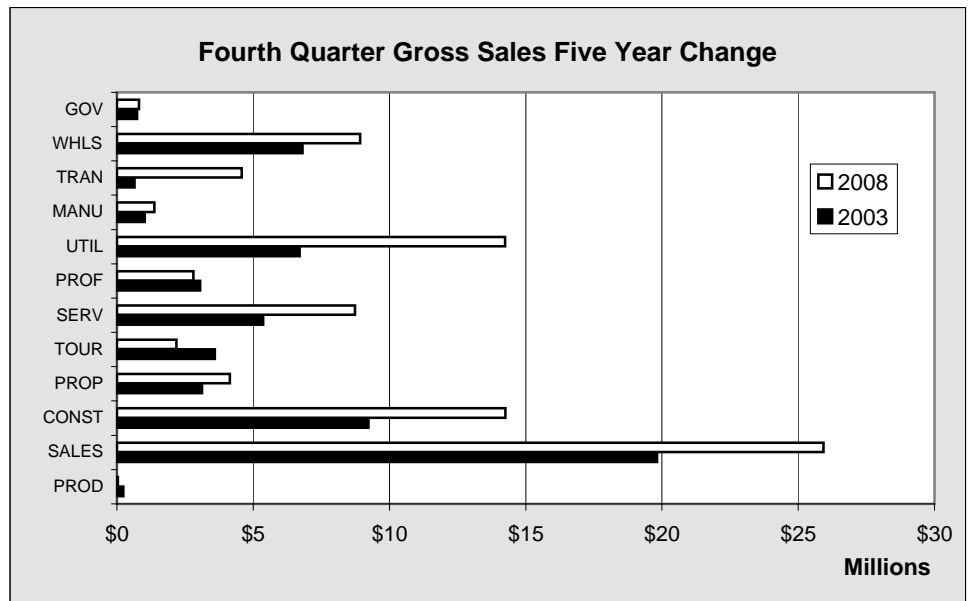

Chart 2.2

Homer Sales

Homer Fourth Quarter TAXABLE Sales by Line of Business - 2003-2008 - in \$								
LOB	2003	2004	2005	2006	2007	2008	Annual Percent Change	Annual Amount Change
PROD	8,985	20,600	19,566	16,055	24,210	13,400	-44.7%	-10,810
SALES	14,127,874	14,069,911	14,338,902	15,492,322	16,616,199	18,348,833	10.4%	1,732,634
CONST	271,756	244,390	238,800	272,837	312,248	443,960	42.2%	131,712
PROP	1,329,590	1,364,652	1,329,254	1,406,808	1,706,142	1,654,756	-3.0%	-51,386
TOUR	3,019,230	3,004,697	3,159,018	3,306,785	3,248,346	1,435,980	-55.8%	-1,812,366
SERV	3,255,412	3,209,992	3,300,058	3,430,859	3,880,458	3,746,847	-3.4%	-133,611
PROF	559,760	599,207	609,715	677,709	711,541	677,246	-4.8%	-34,295
UTIL	869,889	921,683	996,311	1,243,247	1,089,670	1,379,062	26.6%	289,392
MANU	233,264	223,860	221,214	217,112	288,490	286,643	-0.6%	-1,847
TRAN	154,784	144,626	122,238	136,176	148,073	126,107	-14.8%	-21,966
WHLS	2,531,489	2,946,268	3,464,915	3,440,808	3,800,903	3,848,140	1.2%	47,237
GOV	745,327	749,646	777,246	822,267	885,817	814,123	-8.1%	-71,694
TOTAL	27,107,360	27,499,532	28,577,237	30,462,985	32,712,097	32,775,097	0.2%	63,000

Table 2.4 For complete listing of Lines of Business, see page 13

Fourth Quarter TAXABLE Sales History	
2003	27,107,360
2004	27,499,532
2005	28,577,237
2006	30,462,985
2007	32,712,097
2008	32,775,097

Table 2.5

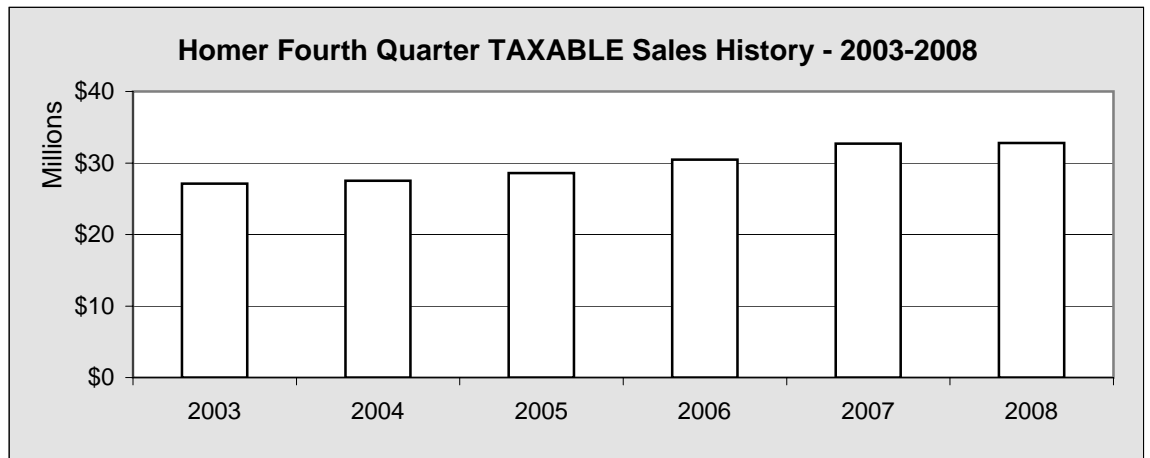
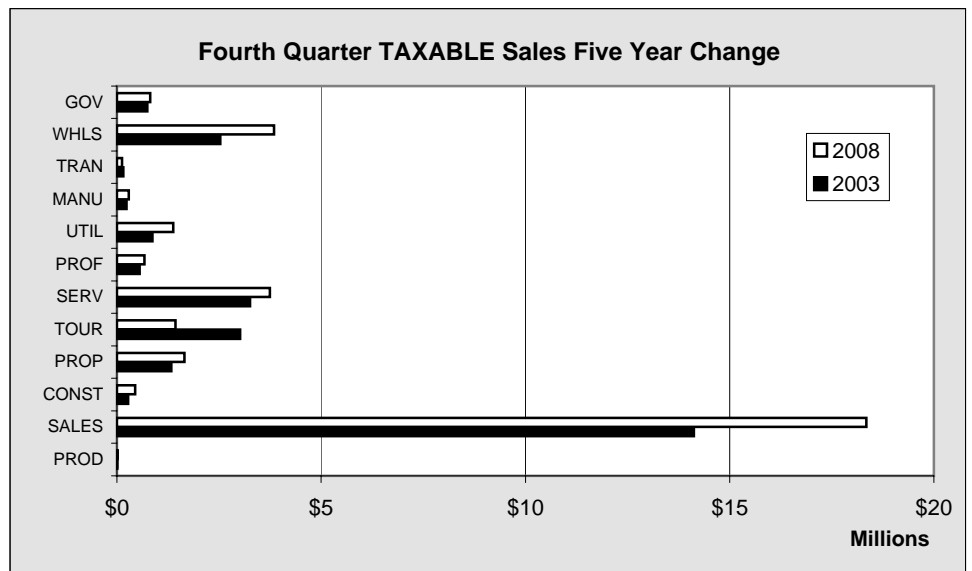

Chart 2.3

Five Year Change Fourth Quarter TAXABLE Sales		
LOB	2003	2008
PROD	8,985	13,400
SALES	14,127,874	18,348,833
CONST	271,756	443,960
PROP	1,329,590	1,654,756
TOUR	3,019,230	1,435,980
SERV	3,255,412	3,746,847
PROF	559,760	677,246
UTIL	869,889	1,379,062
MANU	233,264	286,643
TRAN	154,784	126,107
WHLS	2,531,489	3,848,140
GOV	745,327	814,123
TOTAL	27,107,360	32,775,097

Table 2.6

Chart 2.4



Homer Sales

Homer Annual GROSS Sales by Line of Business - 2003-2008 - in \$

LOB	2003	2004	2005	2006	2007	2008	Annual Percent Change	Annual Amount Change
PROD	591,515	578,112	401,509	369,100	2,365,868	179,854	-92.4%	-2,186,014
SALES	86,594,152	92,094,391	95,289,498	100,483,770	105,875,605	120,051,673	13.4%	14,176,068
CONST	41,476,625	32,025,640	37,661,154	56,046,199	42,882,913	39,327,058	-8.3%	-3,555,855
PROP	12,052,352	13,854,382	13,270,084	14,176,548	16,845,079	18,414,506	9.3%	1,569,427
TOUR	30,616,944	34,850,502	36,775,040	39,661,724	39,520,368	28,543,766	-27.8%	-10,976,602
SERV	25,280,522	27,233,603	29,901,849	35,427,278	41,862,709	43,756,755	4.5%	1,894,046
PROF	10,502,846	10,856,028	9,166,842	8,946,338	10,191,987	9,097,321	-10.7%	-1,094,666
UTIL	27,145,942	31,642,148	34,464,246	43,313,320	35,617,604	45,870,728	28.8%	10,253,124
MANU	5,613,784	5,420,061	5,923,968	6,236,271	7,469,355	7,088,639	-5.1%	-380,716
TRAN	4,104,423	5,200,713	4,445,884	5,653,305	8,718,520	19,402,676	122.5%	10,684,156
WHLS	26,430,585	32,846,550	38,020,032	41,916,295	37,993,258	46,931,310	23.5%	8,938,052
GOV	3,664,092	3,821,622	3,948,647	3,997,559	4,108,884	4,250,013	3.4%	141,129
TOTAL	274,073,782	290,423,752	309,268,753	356,227,707	353,452,150	382,914,299	8.3%	29,462,149

Table 2.7

For complete listing of Lines of Business, see page 13

Annual GROSS Sales History	
2003	274,073,782
2004	290,423,752
2005	309,268,753
2006	356,227,707
2007	353,452,150
2008	382,914,299

Table 2.8

Chart 2.5

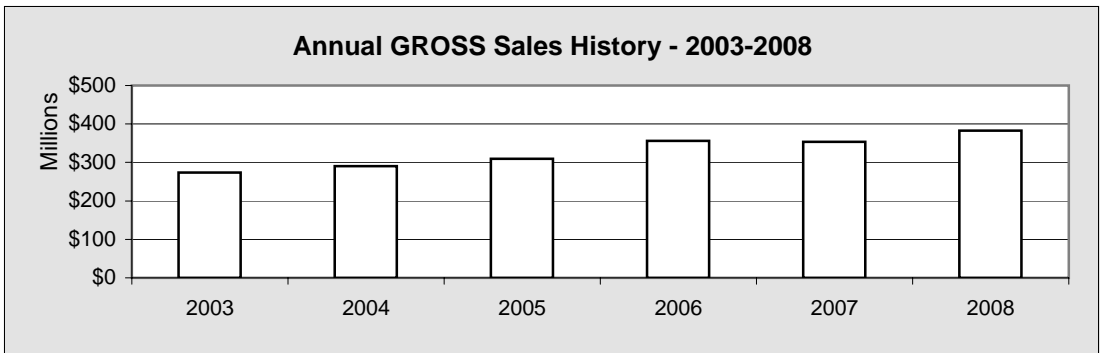

Five Year Change Annual GROSS Sales		
LOB	2003	2008
PROD	591,515	179,854
SALES	86,594,152	120,051,673
CONST	41,476,625	39,327,058
PROP	12,052,352	18,414,506
TOUR	30,616,944	28,543,766
SERV	25,280,522	43,756,755
PROF	10,502,846	9,097,321
UTIL	27,145,942	45,870,728
MANU	5,613,784	7,088,639
TRAN	4,104,423	19,402,676
WHLS	26,430,585	46,931,310
GOV	3,664,092	4,250,013
TOTAL	274,073,782	382,914,299

Table 2.9

Chart 2.6

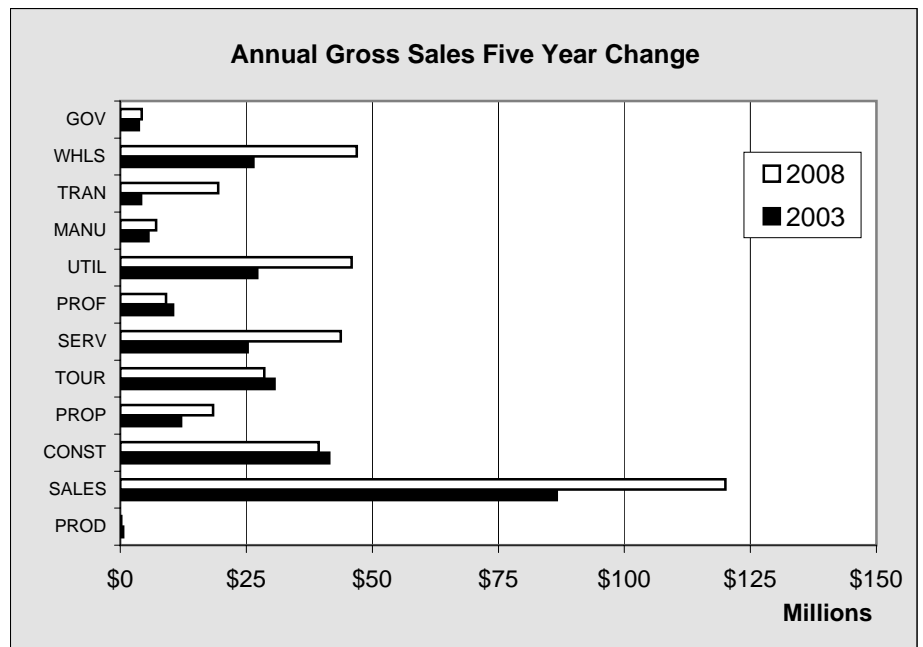

Homer Sales

Homer Annual TAXABLE Sales by Line of Business - 2003-2008 - in \$								
LOB	2003	2004	2005	2006	2007	2008	Annual Percent Change	Annual Amount Change
PROD	81,146	98,715	114,749	118,806	131,974	111,890	-15.2%	-20,084
SALES	61,814,637	64,566,619	65,900,008	70,072,643	75,219,488	88,639,102	17.8%	13,419,614
CONST	1,195,200	1,047,393	1,001,934	1,005,362	1,135,005	1,501,889	32.3%	366,884
PROP	5,690,743	6,300,936	6,001,107	6,274,656	7,437,109	7,987,267	7.4%	550,158
TOUR	25,461,636	28,294,331	29,762,284	31,954,906	33,470,820	23,196,100	-30.7%	-10,274,720
SERV	14,037,667	14,612,060	14,560,746	15,112,276	18,205,719	18,898,404	3.8%	692,685
PROF	2,504,002	2,533,505	2,621,600	2,831,562	3,004,851	2,886,153	-4.0%	-118,698
UTIL	3,561,037	3,464,301	3,855,271	4,456,860	4,496,375	4,886,007	8.7%	389,632
MANU	1,276,489	1,267,771	1,121,485	1,149,768	1,567,291	1,581,031	0.9%	13,740
TRAN	1,101,874	717,019	679,313	735,429	624,681	704,654	12.8%	79,973
WHLS	11,340,673	13,251,309	15,190,505	15,733,320	17,128,509	18,385,963	7.3%	1,257,454
GOV	3,664,092	3,821,622	3,948,647	3,939,804	4,079,127	4,232,334	3.8%	153,207
TOTAL	131,729,196	139,975,581	144,757,649	153,385,392	166,500,949	173,010,794	3.9%	6,509,845

Table 2.10

For complete listing of Lines of Business, see page 13

Annual TAXABLE Sales History	
2003	131,729,196
2004	139,975,581
2005	144,757,649
2006	153,385,392
2007	166,500,949
2008	173,010,794

Table 2.11

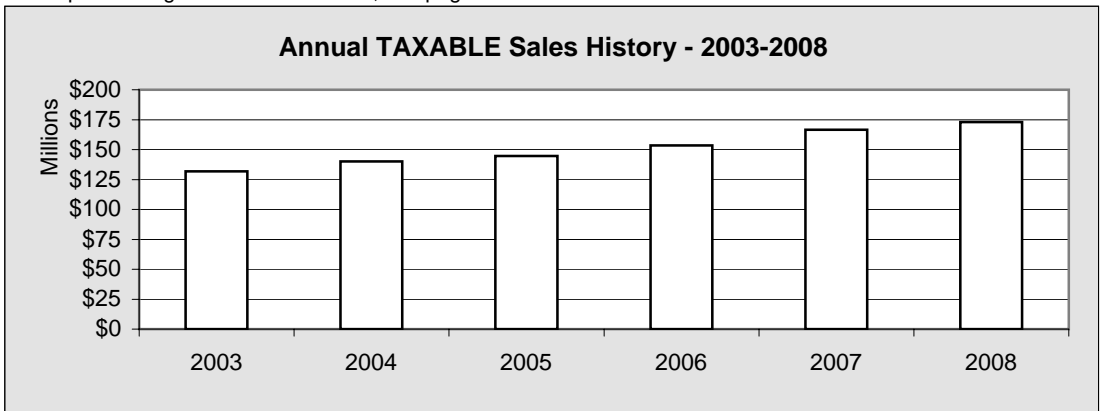
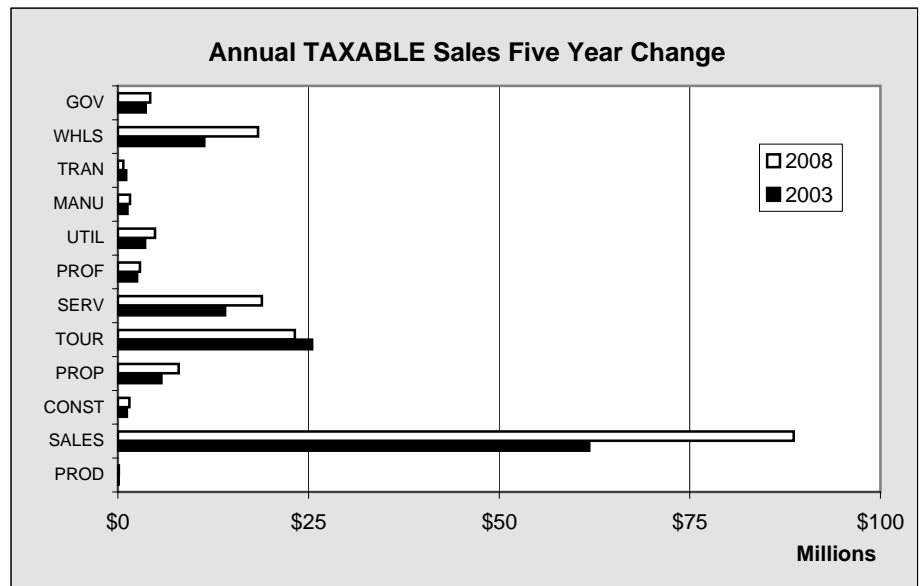

Chart 2.7

Five Year Change Annual TAXABLE Sales		
LOB	2003	2008
PROD	81,146	111,890
SALES	61,814,637	88,639,102
CONST	1,195,200	1,501,889
PROP	5,690,743	7,987,267
TOUR	25,461,636	23,196,100
SERV	14,037,667	18,898,404
PROF	2,504,002	2,886,153
UTIL	3,561,037	4,886,007
MANU	1,276,489	1,581,031
TRAN	1,101,874	704,654
WHLS	11,340,673	18,385,963
GOV	3,664,092	4,232,334
TOTAL	131,729,196	173,010,794

Table 2.12

Chart 2.8



Homer Sales

Homer GROSS Sales by Line of Business by Quarter - 2008 - in \$					
LOB	1st Quarter	2nd Quarter	3rd Quarter	4th Quarter	Total
Resource Production	12,439	75,172	55,339	36,904	179,854
Sales	20,905,563	33,745,784	39,479,740	25,920,586	120,051,673
Construction	6,558,907	8,124,580	10,386,248	14,257,323	39,327,058
Property	3,668,644	4,747,221	5,850,457	4,148,184	18,414,506
Tourism	1,846,023	8,901,554	15,617,028	2,179,161	28,543,766
Services	6,943,172	14,755,603	13,317,561	8,740,419	43,756,755
Professional	1,849,454	2,131,699	2,308,155	2,808,013	9,097,321
Utility	10,452,195	9,615,450	11,557,324	14,245,759	45,870,728
Manufacturing	1,373,626	2,202,875	2,133,009	1,379,129	7,088,639
Transportation & Warehousing	2,821,905	4,876,818	7,125,075	4,578,878	19,402,676
Wholesale	8,629,201	13,001,357	16,373,406	8,927,346	46,931,310
Government	646,989	1,036,947	1,751,954	814,123	4,250,013
TOTAL	65,708,118	103,215,060	125,955,296	88,035,825	382,914,299

Table 2.13

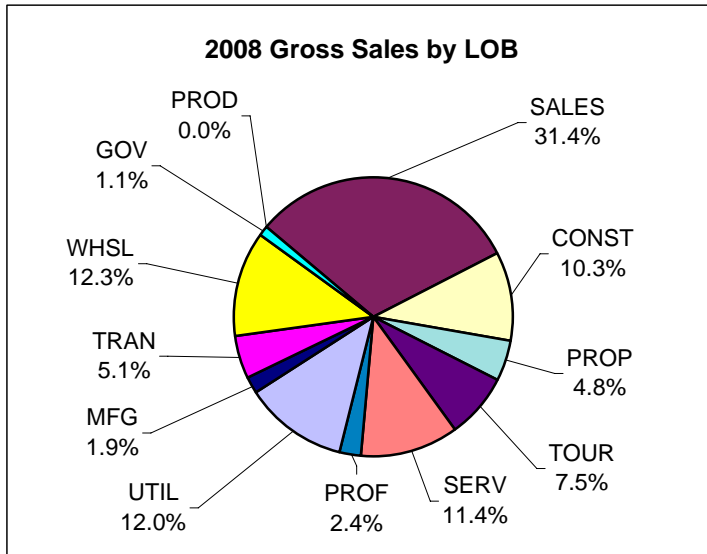

Chart 2.9

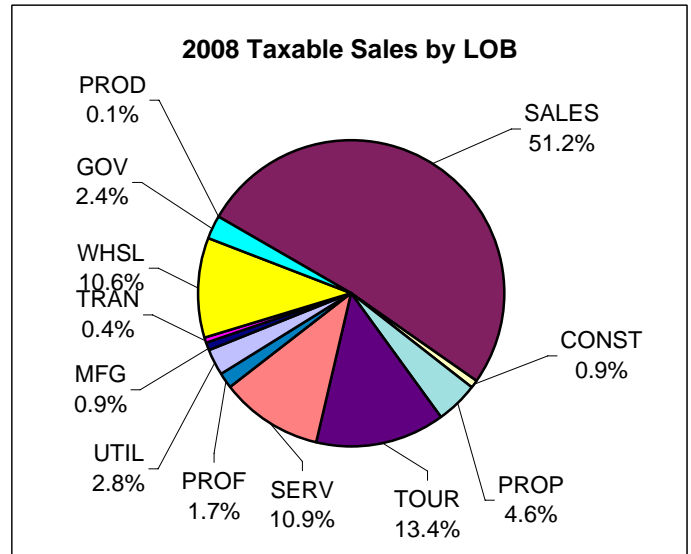

Chart 2.10

Homer TAXABLE Sales by Line of Business by Quarter - 2008 - in \$					
LOB	1st Quarter	2nd Quarter	3rd Quarter	4th Quarter	Total
Resource Production	3,279	59,337	35,874	13,400	111,890
Sales	15,823,665	25,188,641	29,277,963	18,348,833	88,639,102
Construction	285,389	358,110	414,430	443,960	1,501,889
Property	1,347,588	2,193,127	2,791,796	1,654,756	7,987,267
Tourism	1,541,340	7,183,236	13,035,544	1,435,980	23,196,100
Services	3,776,234	5,259,295	6,116,028	3,746,847	18,898,404
Professional	726,408	763,674	718,825	677,246	2,886,153
Utility	1,266,531	1,147,715	1,092,699	1,379,062	4,886,007
Manufacturing	221,432	480,290	592,666	286,643	1,581,031
Transportation & Warehousing	122,382	199,534	256,631	126,107	704,654
Wholesale	3,261,680	5,001,690	6,274,453	3,848,140	18,385,963
Government	646,989	1,036,947	1,734,275	814,123	4,232,334
TOTAL	29,022,917	48,871,596	62,341,184	32,775,097	173,010,794

Table 2.14

Homer Sales

Homer GROSS Sales by Line of Business by Quarter - 2007 - in \$					
LOB	1st Quarter	2nd Quarter	3rd Quarter	4th Quarter	Total
Resource Production	36,802	103,362	776,896	1,448,808	2,365,868
Sales	17,449,718	29,434,729	34,037,204	24,953,954	105,875,605
Construction	6,818,503	10,216,524	16,142,373	9,705,513	42,882,913
Property	2,881,498	4,421,535	5,425,103	4,116,943	16,845,079
Tourism	3,680,509	12,253,266	19,771,716	3,814,877	39,520,368
Services	6,758,058	13,105,824	13,659,930	8,338,897	41,862,709
Professional	2,560,602	2,399,254	2,414,679	2,817,452	10,191,987
Utility	11,496,157	11,107,659	1,854,484	11,159,304	35,617,604
Manufacturing	1,263,209	2,065,820	2,339,827	1,800,499	7,469,355
Transportation & Warehousing	649,338	1,096,320	3,838,163	3,134,699	8,718,520
Wholesale	7,218,174	10,095,243	11,847,065	8,832,776	37,993,258
Government	611,944	991,182	1,619,941	885,817	4,108,884
TOTAL	61,424,512	97,290,718	113,727,381	81,009,539	353,452,150

Table 2.15

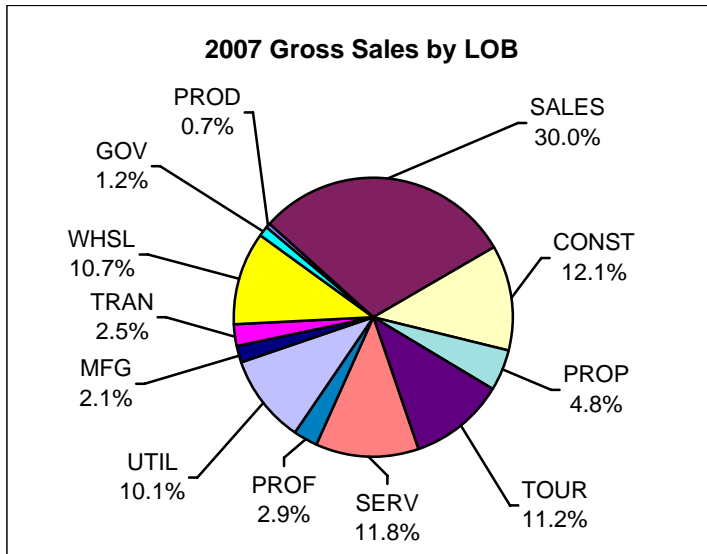

Chart 2.11

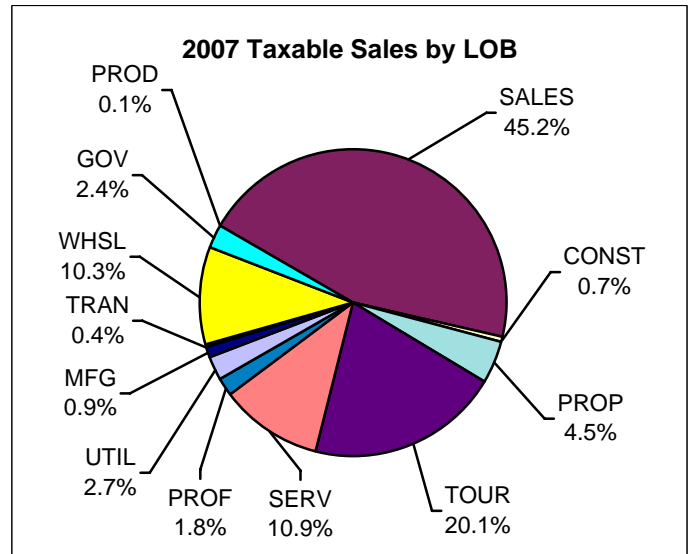

Chart 2.12

Homer TAXABLE Sales by Line of Business by Quarter - 2007 - in \$					
LOB	1st Quarter	2nd Quarter	3rd Quarter	4th Quarter	Total
Resource Production	4,257	53,232	50,275	24,210	131,974
Sales	13,136,717	21,438,770	24,027,802	16,616,199	75,219,488
Construction	187,017	275,777	359,963	312,248	1,135,005
Property	1,168,537	1,823,258	2,739,172	1,706,142	7,437,109
Tourism	3,310,379	10,296,241	16,615,854	3,248,346	33,470,820
Services	3,223,344	5,160,491	5,941,426	3,880,458	18,205,719
Professional	718,854	841,092	733,364	711,541	3,004,851
Utility	1,352,338	1,029,995	1,024,372	1,089,670	4,496,375
Manufacturing	199,579	486,717	592,505	288,490	1,567,291
Transportation & Warehousing	107,100	175,667	193,841	148,073	624,681
Wholesale	3,234,493	4,595,812	5,497,301	3,800,903	17,128,509
Government	611,944	991,182	1,590,184	885,817	4,079,127
TOTAL	27,254,559	47,168,234	59,366,059	32,712,097	166,500,949

Table 2.16

Homer Sales

Homer GROSS Sales by Line of Business by Quarter - 2006 - in \$					
LOB	1st Quarter	2nd Quarter	3rd Quarter	4th Quarter	Total
Resource Production	31,679	124,270	137,400	75,751	369,100
Sales	17,557,481	28,040,235	32,132,916	22,753,138	100,483,770
Construction	4,461,809	7,237,619	22,824,100	21,522,671	56,046,199
Property	2,578,348	3,470,648	4,430,532	3,697,020	14,176,548
Tourism	3,648,044	12,389,123	19,852,415	3,772,142	39,661,724
Services	6,625,256	11,644,771	9,249,884	7,907,367	35,427,278
Professional	1,791,923	2,207,945	2,010,147	2,936,323	8,946,338
Utility	10,418,274	10,115,928	10,735,993	12,043,125	43,313,320
Manufacturing	1,041,511	1,826,125	1,806,035	1,562,600	6,236,271
Transportation & Warehousing	703,817	1,052,012	2,545,922	1,351,554	5,653,305
Wholesale	6,685,091	10,183,413	11,198,192	13,849,599	41,916,295
Government	613,530	1,022,191	1,539,571	822,267	3,997,559
TOTAL	56,156,763	89,314,280	118,463,107	92,293,557	356,227,707

Table 2.17

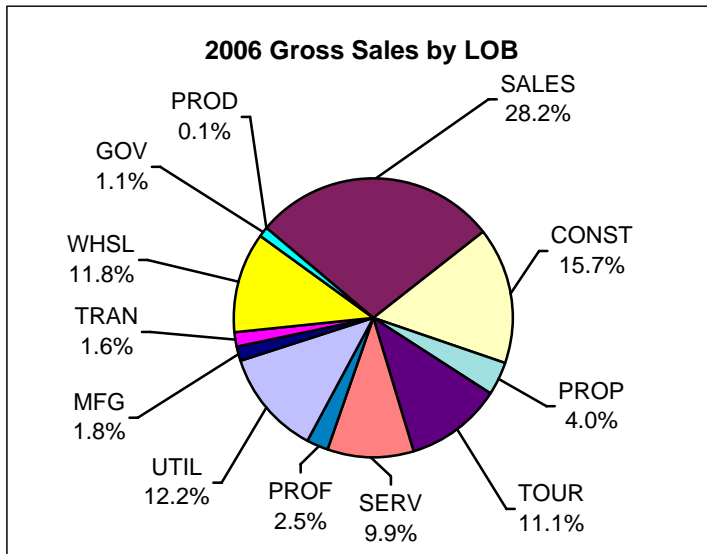

Chart 2.13

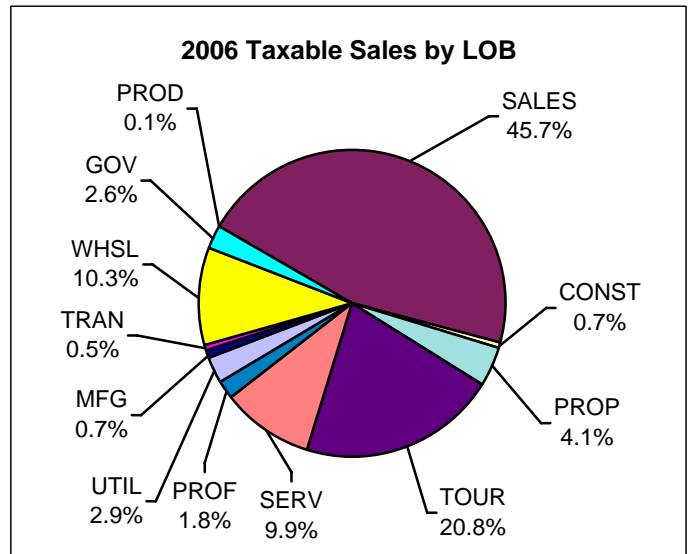

Chart 2.14

Homer TAXABLE Sales by Line of Business by Quarter - 2006 - in \$					
LOB	1st Quarter	2nd Quarter	3rd Quarter	4th Quarter	Total
Resource Production	1,835	56,701	44,215	16,055	118,806
Sales	12,435,797	19,916,203	22,228,321	15,492,322	70,072,643
Construction	183,645	251,319	297,561	272,837	1,005,362
Property	1,139,517	1,549,941	2,178,390	1,406,808	6,274,656
Tourism	3,284,468	9,769,324	15,594,329	3,306,785	31,954,906
Services	3,068,824	4,146,056	4,466,537	3,430,859	15,112,276
Professional	654,433	800,041	699,379	677,709	2,831,562
Utility	1,279,979	1,006,828	926,806	1,243,247	4,456,860
Manufacturing	163,090	345,514	424,052	217,112	1,149,768
Transportation & Warehousing	137,598	227,184	234,471	136,176	735,429
Wholesale	2,754,910	4,302,775	5,234,827	3,440,808	15,733,320
Government	613,530	996,266	1,507,741	822,267	3,939,804
TOTAL	25,717,626	43,368,152	53,836,629	30,462,985	153,385,392

Table 2.18

Homer Sales

Homer Annual Gross Sales by Quarter - in \$						
	1st Quarter	2nd Quarter	3rd Quarter	4th Quarter	Total	Annual Change
1995	32,193,561	48,092,891	66,559,556	50,757,887	197,603,895	
1996	40,009,169	53,691,216	60,425,514	45,000,789	199,126,688	0.8%
1997	39,502,354	55,496,297	62,490,851	45,710,368	203,199,870	2.0%
1998	41,054,484	53,702,365	70,886,151	46,799,617	212,442,617	4.5%
1999	39,553,648	53,874,362	66,354,543	44,068,392	203,850,945	-4.0%
2000	38,455,167	59,287,582	70,009,668	48,229,307	215,981,724	6.0%
2001	40,844,978	56,857,475	77,453,956	54,547,098	229,703,507	6.4%
2002*	44,269,653	68,675,179	89,708,860	60,586,992	263,240,684	14.6%
2003	51,228,276	75,287,944	87,226,845	60,330,717	274,073,782	4.1%
2004	48,145,060	75,761,464	93,912,813	72,604,415	290,423,752	6.0%
2005	51,885,093	85,895,824	100,977,789	70,510,047	309,268,753	6.5%
2006	56,156,763	89,314,280	118,463,107	92,293,557	356,227,707	15.2%
2007	61,424,512	97,290,718	113,727,381	81,009,539	353,452,150	-0.8%
2008	65,708,118	103,215,060	125,955,296	88,035,825	382,914,299	8.3%
Change	7.0%	6.1%	10.8%	8.7%	8.3%	

Table 2.19

Homer Annual Taxable Sales by Quarter - in \$						
	1st Quarter	2nd Quarter	3rd Quarter	4th Quarter	Total	Annual Change
1995	14,797,530	24,901,076	30,398,162	18,098,624	88,195,392	
1996	15,811,688	25,240,189	30,539,871	18,331,480	89,923,228	2.0%
1997	16,213,730	25,960,313	31,654,939	19,496,943	93,325,925	3.8%
1998	16,418,580	26,366,097	32,103,748	19,552,917	94,441,342	1.2%
1999	16,638,467	26,939,183	34,246,601	20,325,107	98,149,358	3.9%
2000	17,327,860	28,797,872	35,677,211	21,387,173	103,190,116	5.1%
2001	17,765,204	30,191,477	37,574,702	21,780,156	107,311,539	4.0%
2002*	18,699,958	34,270,923	43,258,197	25,063,470	121,292,548	13.0%
2003	22,456,282	37,038,468	45,127,086	27,107,360	131,729,196	8.6%
2004	23,828,394	39,657,774	48,989,881	27,499,532	139,975,581	6.3%
2005	24,336,691	41,201,861	50,641,860	28,577,237	144,757,649	3.4%
2006	25,717,626	43,368,152	53,836,629	30,462,985	153,385,392	6.0%
2007	27,254,559	47,168,234	59,366,059	32,712,097	166,500,949	8.6%
2008	29,022,917	48,871,596	62,341,184	32,775,097	173,010,794	3.9%
Change	6.5%	3.6%	5.0%	0.2%	3.9%	

Table 2.20

Homer Annual Non-Taxable Sales by Quarter - in \$						
	1st Quarter	2nd Quarter	3rd Quarter	4th Quarter	Total	Annual Change
1995	17,396,031	23,191,815	36,161,394	32,659,263	109,408,503	
1996	24,197,481	28,451,027	29,885,643	26,669,309	109,203,460	-0.2%
1997	23,288,624	29,535,984	30,835,912	26,213,425	109,873,945	0.6%
1998	24,635,904	27,336,268	38,782,403	27,246,700	118,001,275	7.4%
1999	22,915,181	26,935,179	32,107,942	23,743,285	105,701,587	-10.4%
2000	21,127,307	30,489,710	34,332,457	26,842,134	112,791,608	6.7%
2001	23,079,774	26,665,998	39,879,254	32,766,942	122,391,968	8.5%
2002*	25,569,695	34,404,256	46,450,663	35,523,522	141,948,136	16.0%
2003	28,771,994	38,249,476	42,099,759	33,223,357	142,344,586	0.3%
2004	24,316,666	36,103,690	44,922,932	45,104,883	150,448,171	5.7%
2005	27,548,402	44,693,963	50,335,929	41,932,810	164,511,104	9.3%
2006	30,439,137	45,946,128	64,626,478	61,830,572	202,842,315	23.3%
2007	34,169,953	50,122,484	54,361,322	48,297,442	186,951,201	-7.8%
2008	36,685,201	54,343,464	63,614,112	55,260,728	209,903,505	12.3%
Change	7.4%	8.4%	17.0%	14.4%	12.3%	

Table 2.21 * - Effective April 1, 2002, Homer annexed an area that increased it's area by 28%.

Homer Construction Permits

Homer 4th Quarter Permit VALUES by Type - 2002-2008 - in

	2002	2003	2004	2005	2006	2007	2008	Annual Change
Residential New	560,200	1,222,900	377,000	895,000	550,000	845,000	890,000	5.3%
Residential Alter/Add	104,320	50,000	437,000	80,000	5,000	476,000	610,000	28.2%
Commercial New	78,000	1,600,000	2,560,000	1,975,000	2,000,000	301,000	560,000	86.0%
Commercial Alter/Add	72,000	170,000	17,000	27,000	0	0	824,000	0.0%
Total	814,520	3,042,900	3,391,000	2,977,000	2,555,000	1,622,000	2,884,000	77.8%
Annual Change		273.6%	11.4%	-12.2%	-14.2%	-36.5%	77.8%	

Table 2.22

Homer 4th Quarter Permit VALUES by Type - 1986-2008

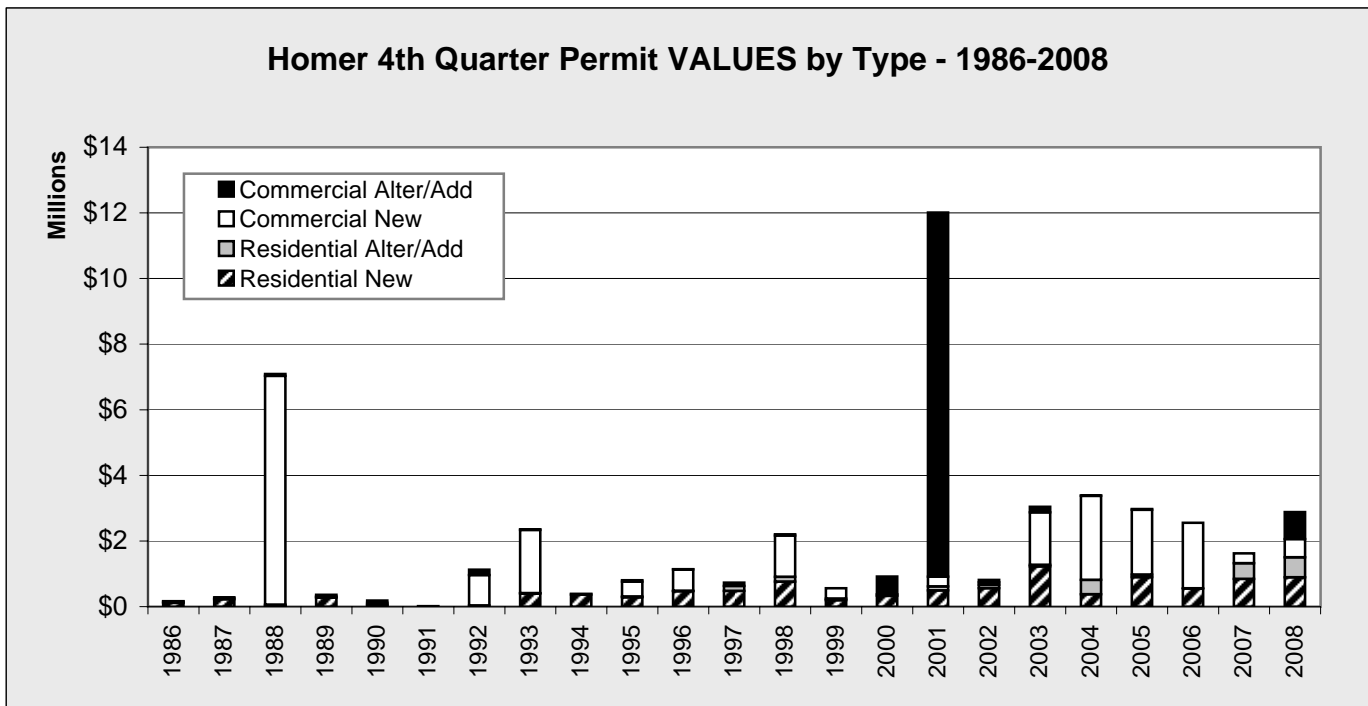

Chart 2.15

**Homer 4th Quarter Permit VALUES
Percent by Type - 2008**

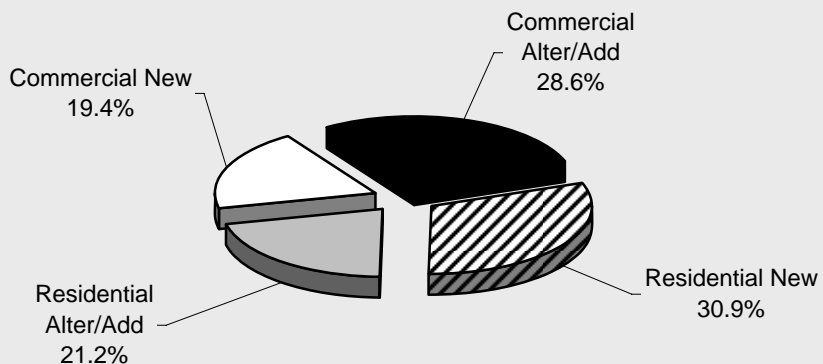

Chart 2.16

Homer Construction Permits

Homer 4th Quarter Permit VOLUME by Type - 2002-2008

	2002	2003	2004	2005	2006	2007	2008	Annual Change
Residential New	5	9	6	6	2	5	5	0.0%
Residential Alter/Add	6	2	9	2	1	8	4	-50.0%
Commercial New	1	1	7	2	2	3	1	-66.7%
Commercial Alter/Add	1	1	2	1	0	0	1	NA
Total	13	13	24	11	5	16	11	-31.3%
Annual Change		0.0%	84.6%	-54.2%	-54.5%	220.0%	-31.3%	

Table 2.23

Homer 4th Quarter Permit VOLUME by Type - 1986-2008

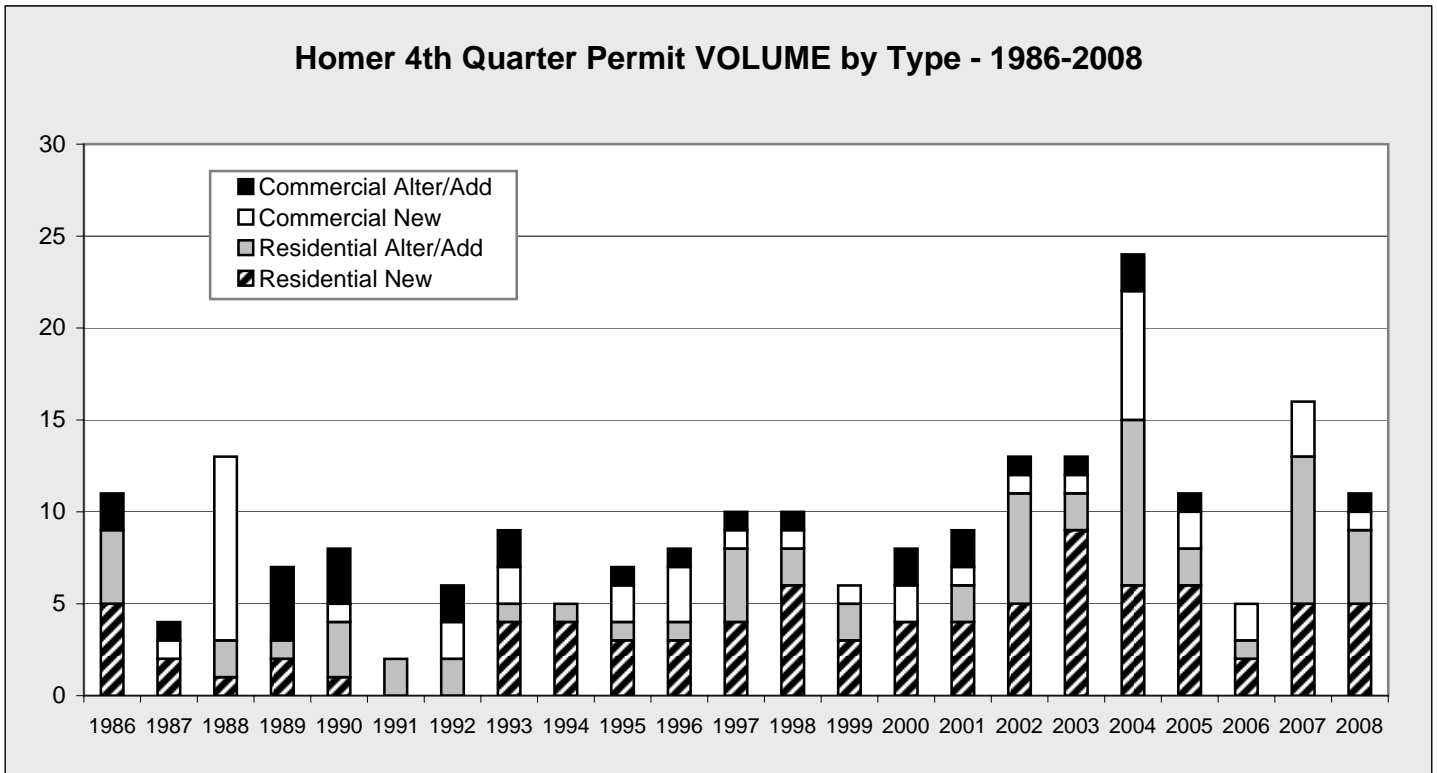

Chart 2.17

Homer 4th Quarter Permit VOLUME Percent by Type - 2008

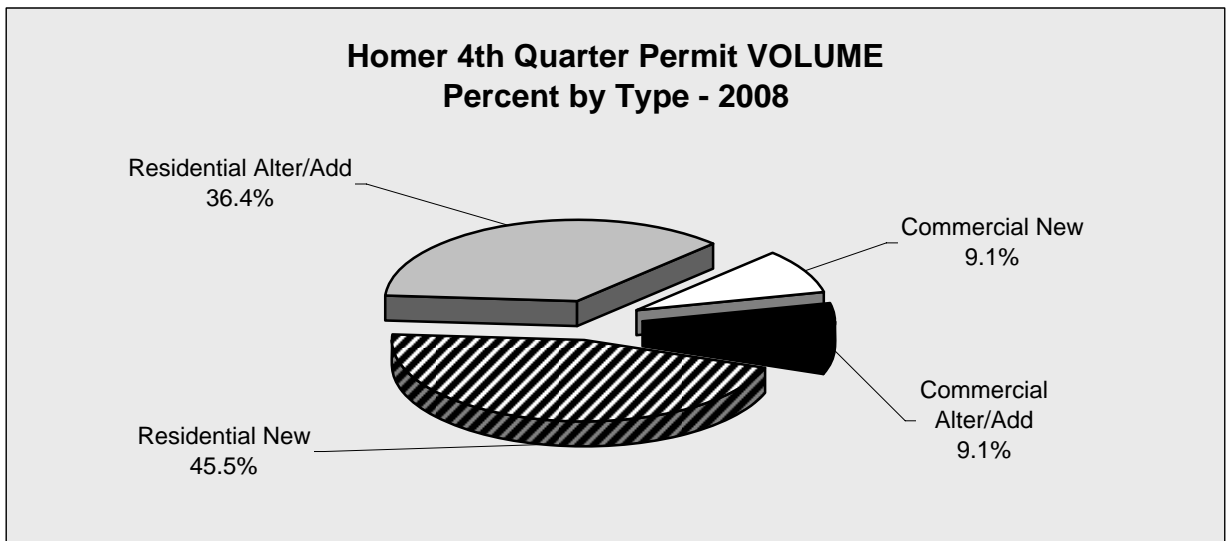

Chart 2.18

Homer Construction Permits

Homer Annual Permit VALUES by Type - 2002-2008 - in \$								
	2002	2003	2004	2005	2006	2007	2008	Annual Change
Residential New	4,226,720	8,120,455	6,695,500	7,209,900	10,055,800	7,650,100	10,126,200	32.4%
Residential Alter/Add	536,620	806,600	1,695,550	906,500	541,057	1,632,500	994,000	-39.1%
Commercial New	4,990,740	5,764,520	14,400,518	11,796,000	8,071,000	4,707,601	10,560,000	124.3%
Commercial Alter/Add	294,699	635,240	1,279,063	1,699,000	1,620,000	66,001	1,488,000	2154.5%
Total	10,048,779	15,326,815	24,070,631	21,611,400	20,287,857	14,056,202	23,168,200	64.8%
Annual Change		52.5%	57.0%	-10.2%	-6.1%	-30.7%	64.8%	

Table 2.24

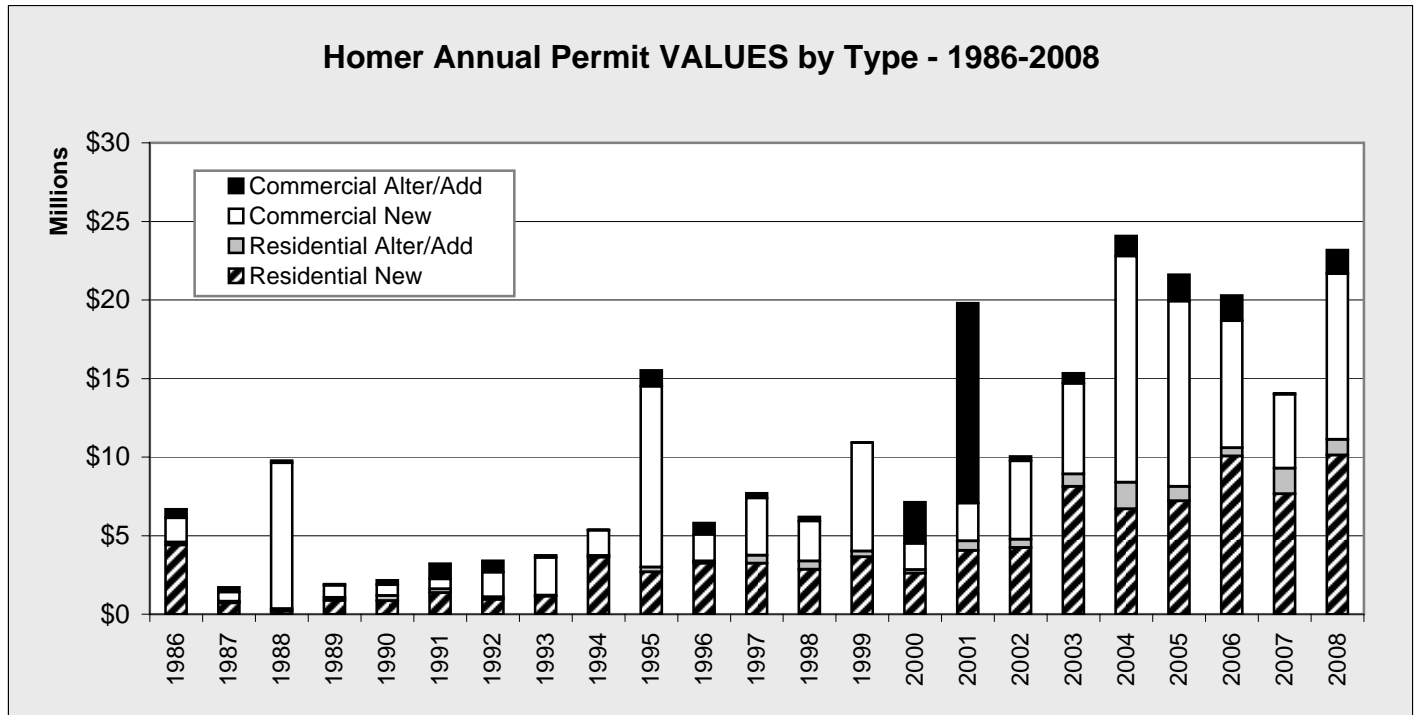

Chart 2.19

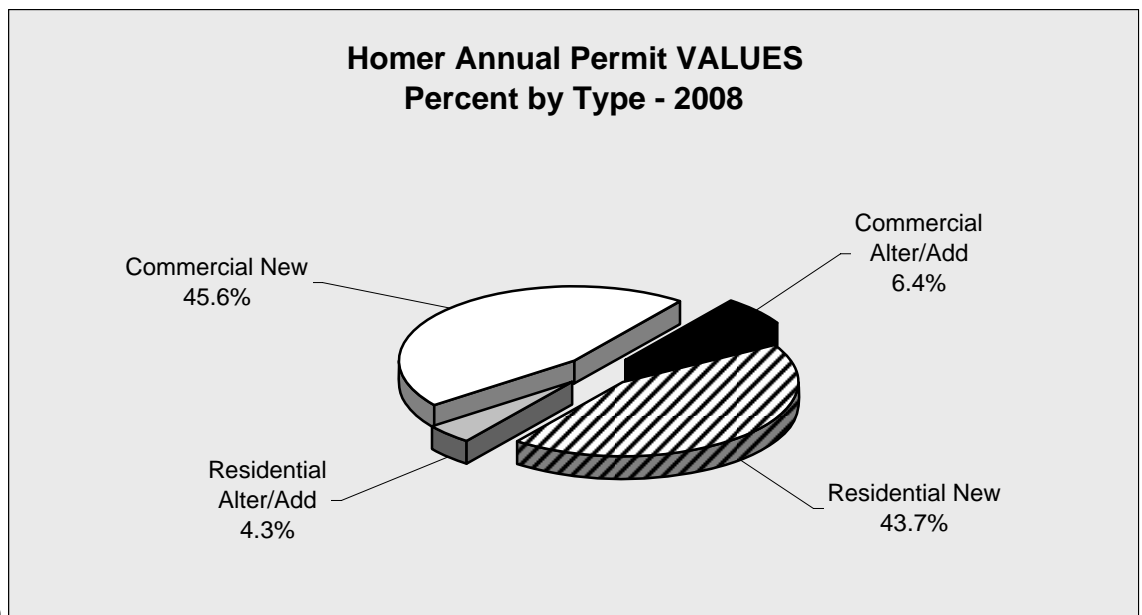

Chart 2.20

Homer Construction Permits

Homer Annual Permit VOLUME by Type - 2002-2008								
	2002	2003	2004	2005	2006	2007	2008	Annual Change
Residential New	32	47	41	51	49	41	38	-7.3%
Residential Alter/Add	20	19	37	25	16	28	18	-35.7%
Commercial New	8	11	22	18	14	16	3	-81.3%
Commercial Alter/Add	7	9	8	9	4	2	3	50.0%
Total	67	86	108	103	83	87	62	-28.7%
Annual Change		28.4%	25.6%	-4.6%	-19.4%	4.8%	-28.7%	

Table 2.25

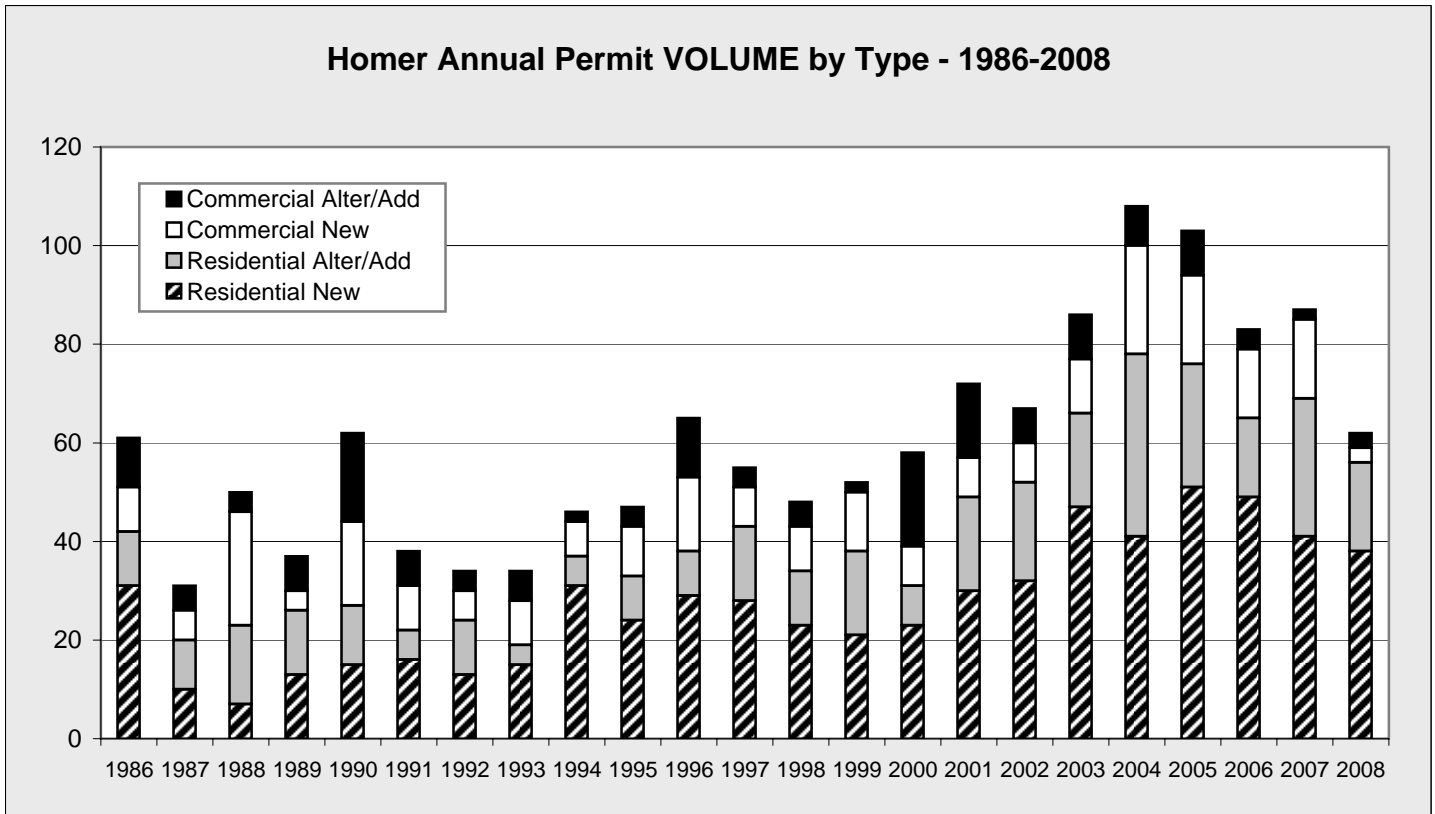

Chart 2.21

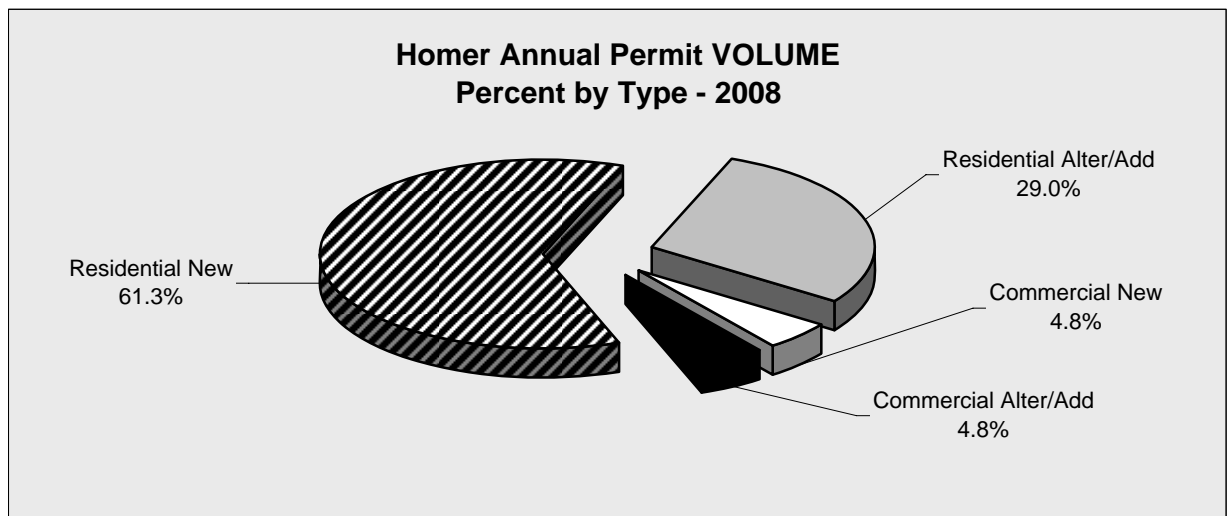

Chart 2.22

Homer Construction Permits

Homer Annual Permit VALUE by Type by Quarter - 2001-2008 - in \$					
	1st Quarter	2nd Quarter	3rd Quarter	4th Quarter	Total
2001					
Residential - New	300,000	2,093,800	1,161,680	492,300	4,047,780
Residential - Add/Alter	60,000	306,440	122,720	120,000	609,160
Commercial - New	285,000	1,485,800	340,000	300,000	2,410,800
Commercial - Add/Alter	45,000	216,000	1,371,950	11,100,000	12,732,950
TOTAL	690,000	4,102,040	2,996,350	12,012,300	19,800,690
2002					
Residential - New	891,760	1,308,460	1,466,300	560,200	4,226,720
Residential - Add/Alter	8,960	205,400	217,940	104,320	536,620
Commercial - New	0	1,000,000	3,912,740	78,000	4,990,740
Commercial - Add/Alter	28,000	14,349	180,350	72,000	294,699
TOTAL	928,720	2,528,209	5,777,330	814,520	10,048,779
2003					
Residential - New	979,800	3,811,480	2,106,275	1,222,900	8,120,455
Residential - Add/Alter	232,540	239,060	285,000	50,000	806,600
Commercial - New	0	3,535,720	628,800	1,600,000	5,764,520
Commercial - Add/Alter	122,000	343,240	0	170,000	635,240
TOTAL	1,334,340	7,929,500	3,020,075	3,042,900	15,326,815
2004					
Residential - New	2,597,500	2,495,400	1,225,600	377,000	6,695,500
Residential - Add/Alter	201,520	205,730	851,300	437,000	1,695,550
Commercial - New	915,000	4,700,518	6,225,000	2,560,000	14,400,518
Commercial - Add/Alter	0	32,063	1,230,000	17,000	1,279,063
TOTAL	3,714,020	7,433,711	9,531,900	3,391,000	24,070,631
2005					
Residential - New	1,694,400	3,072,000	1,548,500	895,000	7,209,900
Residential - Add/Alter	1,500	451,000	374,000	80,000	906,500
Commercial - New	108,000	7,473,000	2,240,000	1,975,000	11,796,000
Commercial - Add/Alter	1,302,000	250,000	120,000	27,000	1,699,000
TOTAL	3,105,900	11,246,000	4,282,500	2,977,000	21,611,400
2006					
Residential - New	1,645,000	4,250,100	3,610,700	550,000	10,055,800
Residential - Add/Alter	0	287,000	249,057	5,000	541,057
Commercial - New	626,000	2,310,000	3,135,000	2,000,000	8,071,000
Commercial - Add/Alter	1,000,000	620,000	0	0	1,620,000
TOTAL	3,271,000	7,467,100	6,994,757	2,555,000	20,287,857
2007					
Residential - New	55,000	4,705,000	2,045,100	845,000	7,650,100
Residential - Add/Alter	0	482,000	674,500	476,000	1,632,500
Commercial - New	0	2,085,001	2,321,600	301,000	4,707,601
Commercial - Add/Alter	1	20,000	46,000	0	66,001
TOTAL	55,001	7,292,001	5,087,200	1,622,000	14,056,202
2008					
Residential - New	1,195,000	6,488,000	1,553,200	890,000	10,126,200
Residential - Add/Alter	28,000	163,000	193,000	610,000	994,000
Commercial - New	0	10,000,000	0	560,000	10,560,000
Commercial - Add/Alter	0	0	664,000	824,000	1,488,000
TOTAL	1,223,000	16,651,000	2,410,200	2,884,000	23,168,200

Table 2.26

Homer Construction Permits

Homer Annual Permit VOLUME by Type by Quarter - 2001-2008					
	1st Quarter	2nd Quarter	3rd Quarter	4th Quarter	Total
2001					
Residential - New	3	14	9	4	30
Residential - Add/Alter	1	12	4	2	19
Commercial - New	2	3	2	1	8
Commercial - Add/Alter	1	5	7	2	15
TOTAL	7	34	22	9	72
2002					
Residential - New	8	9	10	5	32
Residential - Add/Alter	1	5	8	6	20
Commercial - New	0	1	6	1	8
Commercial - Add/Alter	1	2	3	1	7
TOTAL	10	17	27	13	67
2003					
Residential - New	6	17	15	9	47
Residential - Add/Alter	8	6	3	2	19
Commercial - New	0	7	3	1	11
Commercial - Add/Alter	4	4	0	1	9
TOTAL	18	34	21	13	86
2004					
Residential - New	11	15	9	6	41
Residential - Add/Alter	2	5	21	9	37
Commercial - New	2	5	8	7	22
Commercial - Add/Alter	1	1	4	2	8
TOTAL	16	26	42	24	108
2005					
Residential - New	10	22	13	6	51
Residential - Add/Alter	1	13	9	2	25
Commercial - New	2	10	4	2	18
Commercial - Add/Alter	5	2	1	1	9
TOTAL	18	47	27	11	103
2006					
Residential - New	9	23	15	2	49
Residential - Add/Alter	0	8	7	1	16
Commercial - New	4	5	3	2	14
Commercial - Add/Alter	1	3	0	0	4
TOTAL	14	39	25	5	83
2007					
Residential - New	2	22	12	5	41
Residential - Add/Alter	0	8	12	8	28
Commercial - New	1	9	3	3	16
Commercial - Add/Alter	0	1	1	0	2
TOTAL	3	40	28	16	87
2008					
Residential - New	5	24	4	5	38
Residential - Add/Alter	2	5	7	4	18
Commercial - New	0	2	0	1	3
Commercial - Add/Alter	0	0	2	1	3
TOTAL	7	31	13	11	62

Table 2.27

Kenai Sales

Kenai Fourth Quarter GROSS Sales by Line of Business - 2003-2008 - in \$								
LOB	2003	2004	2005	2006	2007	2008	Annual Percent Change	Annual Amount Change
PROD	1,220,446	95,796,864	74,125,421	39,163,292	39,570,701	40,401,576	2.1%	830,875
SALES	26,756,632	28,191,550	29,584,694	28,854,426	31,883,757	37,596,782	17.9%	5,713,025
CONST	12,228,450	4,367,910	6,164,265	25,445,821	8,775,677	14,736,790	67.9%	5,961,113
PROP	5,561,930	4,209,241	6,120,283	4,552,538	4,796,699	5,114,654	6.6%	317,955
TOUR	3,112,913	3,183,485	3,234,040	3,658,481	3,751,224	1,387,162	-63.0%	-2,364,062
SERV	4,481,388	4,848,725	5,014,776	6,156,783	6,755,744	6,214,042	-8.0%	-541,702
PROF	3,033,535	2,981,915	3,802,730	4,035,843	4,123,322	3,464,020	-16.0%	-659,302
UTIL	2,268,420	2,465,984	2,877,552	3,731,578	3,462,862	4,416,194	27.5%	953,332
MANU	3,274,410	4,227,714	3,997,204	6,528,995	3,194,710	4,267,509	33.6%	1,072,799
TRAN	1,484,043	1,387,014	26,666,009	26,500,017	31,125,914	36,479,760	17.2%	5,353,846
WHLS	8,489,364	15,661,772	12,971,335	13,328,084	20,608,936	14,827,648	-28.1%	-5,781,288
GOV	576,862	639,521	696,392	885,890	872,957	889,398	1.9%	16,441
TOTAL	72,488,393	167,961,695	175,254,701	162,841,748	158,922,503	169,795,535	6.8%	10,873,032

Table 3.1

For complete listing of Lines of Business, see page 13

Fourth Quarter GROSS Sales History	
Year	Amount
2003	72,488,393
2004	167,961,695
2005	175,254,701
2006	162,841,748
2007	158,922,503
2008	169,795,535

Table 3.2

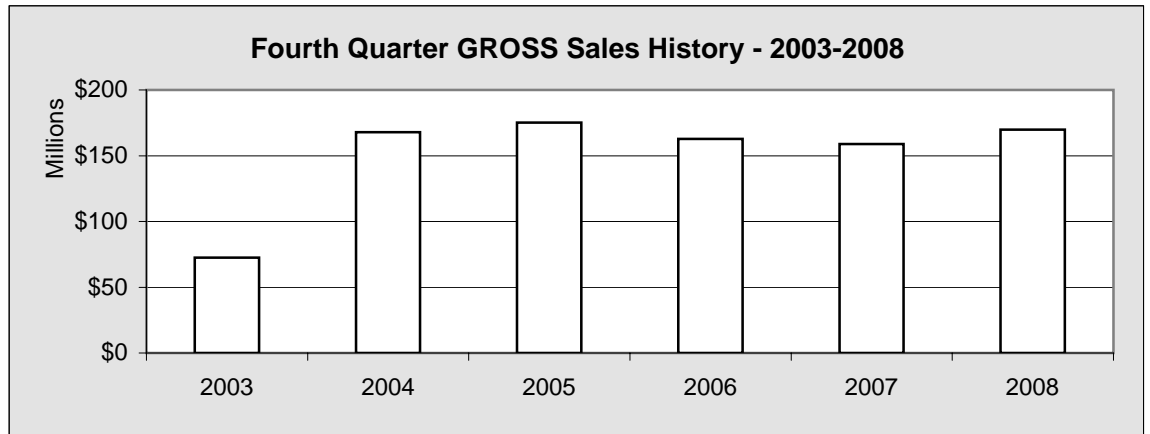

Chart 3.1

Five Year Change Fourth Quarter GROSS Sales		
LOB	2003	2008
PROD	1,220,446	40,401,576
SALES	26,756,632	37,596,782
CONST	12,228,450	14,736,790
PROP	5,561,930	5,114,654
TOUR	3,112,913	1,387,162
SERV	4,481,388	6,214,042
PROF	3,033,535	3,464,020
UTIL	2,268,420	4,416,194
MANU	3,274,410	4,267,509
TRAN	1,484,043	36,479,760
WHLS	8,489,364	14,827,648
GOV	576,862	889,398
TOTAL	72,488,393	169,795,535

Table 3.3

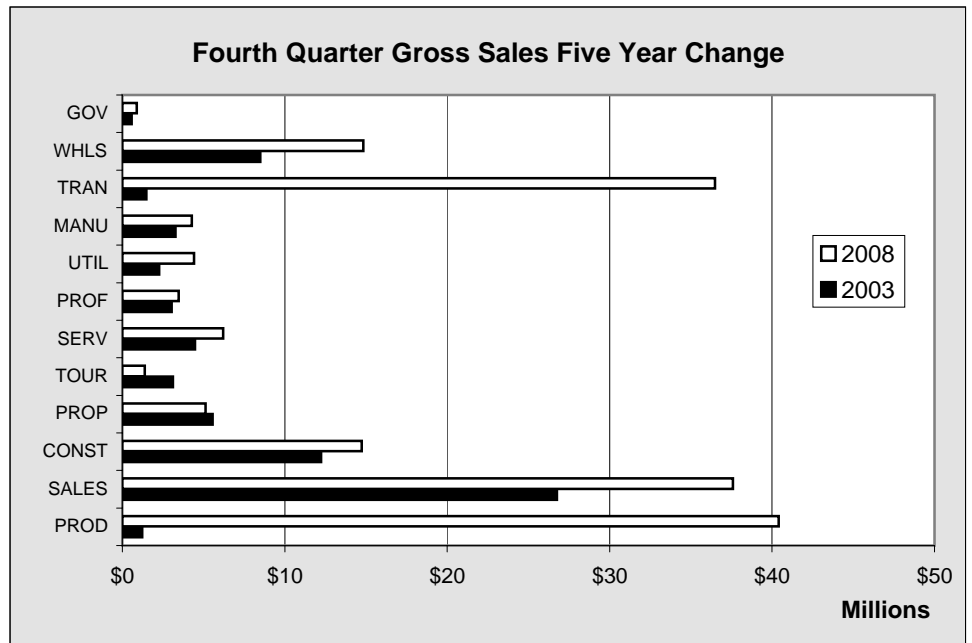

Chart 3.2

Kenai Sales

Kenai Fourth Quarter TAXABLE Sales by Line of Business - 2003-2008 - in \$								
LOB	2003	2004	2005	2006	2007	2008	Annual Percent Change	Annual Amount Change
PROD	124,456	125,523	139,023	118,901	143,911	117,070	-18.7%	-26,841
SALES	15,497,119	16,147,599	17,183,977	18,388,141	20,776,818	24,545,437	18.1%	3,768,619
CONST	347,793	279,048	327,287	354,544	351,062	355,662	1.3%	4,600
PROP	1,841,035	1,833,779	1,891,139	2,087,621	2,250,573	2,497,430	11.0%	246,857
TOUR	2,987,765	3,030,404	3,068,076	3,469,892	3,343,199	1,276,263	-61.8%	-2,066,936
SERV	3,360,919	3,219,510	3,174,727	3,603,418	3,953,409	3,876,794	-1.9%	-76,615
PROF	683,390	758,339	722,902	696,078	703,472	816,963	16.1%	113,491
UTIL	1,429,006	1,524,338	1,696,261	2,148,120	2,052,263	2,494,317	21.5%	442,054
MANU	198,602	141,045	120,693	154,588	202,769	157,554	-22.3%	-45,215
TRAN	160,562	36,488	153,898	110,137	230,080	402,614	75.0%	172,534
WHLS	2,053,781	6,002,971	6,769,421	6,316,534	6,582,845	5,427,051	-17.6%	-1,155,794
GOV	383,599	432,821	464,614	488,813	519,960	490,724	-5.6%	-29,236
TOTAL	29,068,027	33,531,865	35,712,018	37,936,787	41,110,361	42,457,879	3.3%	1,347,518

Table 3.4 For complete listing of Lines of Business, see page 13

Fourth Quarter TAXABLE Sales	
2003	29,068,027
2004	33,531,865
2005	35,712,018
2006	37,936,787
2007	41,110,361
2008	42,457,879

Table 3.5

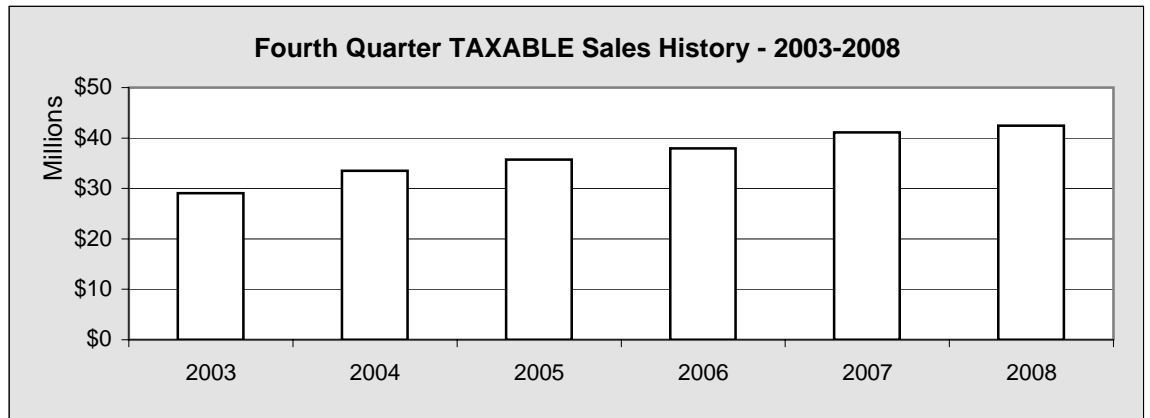

Chart 3.3

Five Year Change Fourth Quarter TAXABLE Sales		
LOB	2003	2008
PROD	124,456	117,070
SALES	15,497,119	24,545,437
CONST	347,793	355,662
PROP	1,841,035	2,497,430
TOUR	2,987,765	1,276,263
SERV	3,360,919	3,876,794
PROF	683,390	816,963
UTIL	1,429,006	2,494,317
MANU	198,602	157,554
TRAN	160,562	402,614
WHLS	2,053,781	5,427,051
GOV	383,599	490,724
TOTAL	29,068,027	42,457,879

Table 3.6

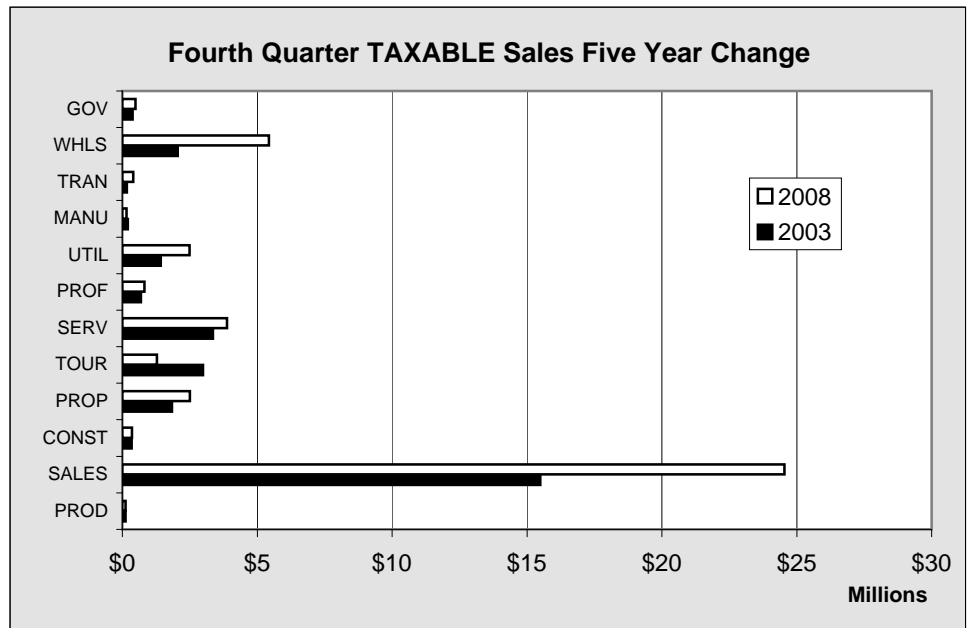

Chart 3.4

Kenai Sales

Kenai Annual GROSS Sales by Line of Business - 2003-2008 - in \$								
LOB	2003	2004	2005	2006	2007	2008	Annual Percent Change	Annual Amount Change
PROD	4,726,857	100,022,855	78,876,010	43,287,832	46,716,466	60,540,134	29.6%	13,823,668
SALES	107,530,358	108,645,907	112,006,670	124,143,661	122,592,351	139,749,141	14.0%	17,156,790
CONST	30,539,441	13,129,482	25,430,918	40,880,928	34,010,065	55,208,519	62.3%	21,198,454
PROP	17,965,712	16,264,986	18,417,832	17,517,133	17,150,510	19,141,133	11.6%	1,990,623
TOUR	14,870,397	15,956,285	16,544,762	18,720,706	18,181,009	8,760,422	-51.8%	-9,420,587
SERV	20,745,270	19,839,374	19,907,748	22,170,304	25,694,573	25,060,324	-2.5%	-634,249
PROF	13,830,788	13,816,386	14,633,670	15,910,045	15,306,314	13,541,236	-11.5%	-1,765,078
UTIL	8,965,563	9,370,432	13,871,188	13,006,437	14,199,488	15,448,408	8.8%	1,248,920
MANU	26,455,314	26,232,173	33,428,325	29,206,480	32,688,259	38,110,739	16.6%	5,422,480
TRAN	4,625,552	17,553,410	66,585,592	74,705,995	119,611,694	150,485,791	25.8%	30,874,097
WHLS	29,926,647	63,578,072	62,846,060	53,888,047	70,341,832	77,529,329	10.2%	7,187,497
GOV	2,700,596	2,862,813	3,231,177	3,494,476	4,064,513	4,101,380	0.9%	36,867
TOTAL	282,882,495	407,272,175	465,779,952	456,932,044	520,557,074	607,676,556	16.7%	87,119,482

Table 3.7

For complete listing of Lines of Business, see page 13

Annual GROSS Sales History	
2003	282,882,495
2004	407,272,175
2005	465,779,952
2006	456,932,044
2007	520,557,074
2008	607,676,556

Table 3.8

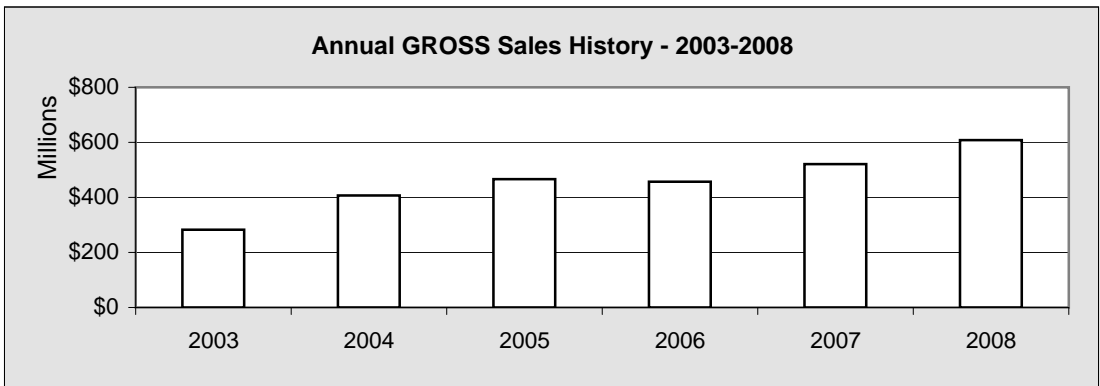

Chart 3.5

Five Year Change Annual GROSS Sales		
LOB	2003	2008
PROD	4,726,857	60,540,134
SALES	107,530,358	139,749,141
CONST	30,539,441	55,208,519
PROP	17,965,712	19,141,133
TOUR	14,870,397	8,760,422
SERV	20,745,270	25,060,324
PROF	13,830,788	13,541,236
UTIL	8,965,563	15,448,408
MANU	26,455,314	38,110,739
TRAN	4,625,552	150,485,791
WHLS	29,926,647	77,529,329
GOV	2,700,596	4,101,380
TOTAL	282,882,495	607,676,556

Table 3.9

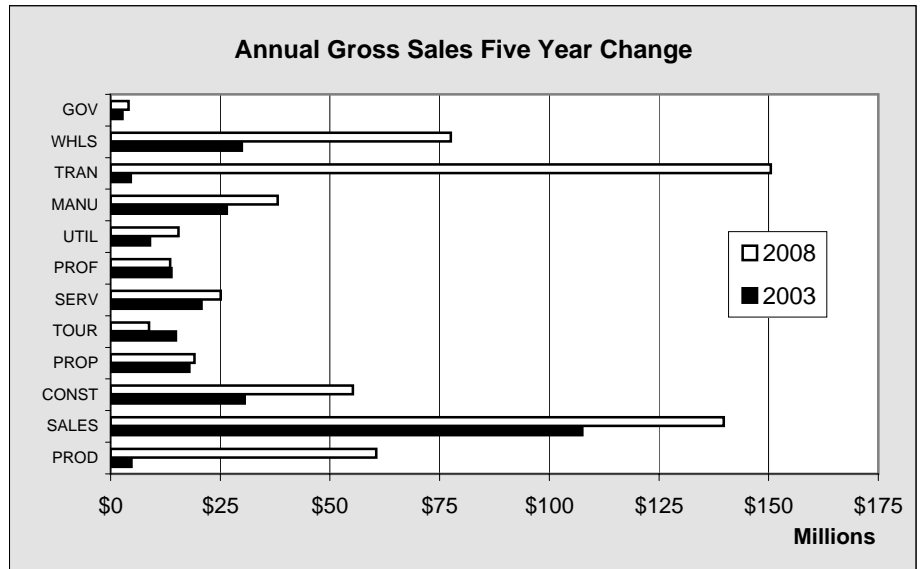

Chart 3.6

Kenai Sales

Kenai Annual TAXABLE Sales by Line of Business - 2003-2008 - in \$								
LOB	2003	2004	2005	2006	2007	2008	Annual Percent Change	Annual Amount Change
PROD	488,890	494,772	467,755	440,218	520,505	520,028	-0.1%	-477
SALES	64,294,562	63,884,387	68,365,098	73,008,240	79,962,518	96,483,648	20.7%	16,521,130
CONST	1,233,344	1,200,427	1,119,137	1,188,349	1,265,859	1,294,990	2.3%	29,131
PROP	8,015,439	7,996,496	7,960,746	8,116,133	8,591,878	9,560,366	11.3%	968,488
TOUR	13,961,938	14,416,689	14,833,825	17,163,429	16,851,017	7,872,506	-53.3%	-8,978,511
SERV	15,434,023	13,740,498	12,853,366	13,875,894	15,927,982	16,054,477	0.8%	126,495
PROF	3,090,294	3,418,239	3,399,151	3,478,120	3,288,890	3,607,232	9.7%	318,342
UTIL	5,509,627	5,765,278	6,386,909	7,605,058	8,465,960	8,906,132	5.2%	440,172
MANU	893,384	1,057,618	1,140,898	883,767	1,061,647	939,292	-11.5%	-122,355
TRAN	318,401	239,198	346,647	670,327	962,740	1,665,116	73.0%	702,376
WHLS	6,336,422	25,239,822	26,564,628	28,050,311	27,805,502	26,632,258	-4.2%	-1,173,244
GOV	1,738,471	1,920,438	2,097,894	2,160,749	2,372,880	2,355,439	-0.7%	-17,441
TOTAL	121,314,795	139,373,862	145,536,054	156,640,595	167,077,378	175,891,484	5.3%	8,814,106

Table 3.10

For complete listing of Lines of Business, see page 13

Annual TAXABLE Sales History	
2003	121,314,795
2004	139,373,862
2005	145,536,054
2006	156,640,595
2007	167,077,378
2008	175,891,484

Table 3.11

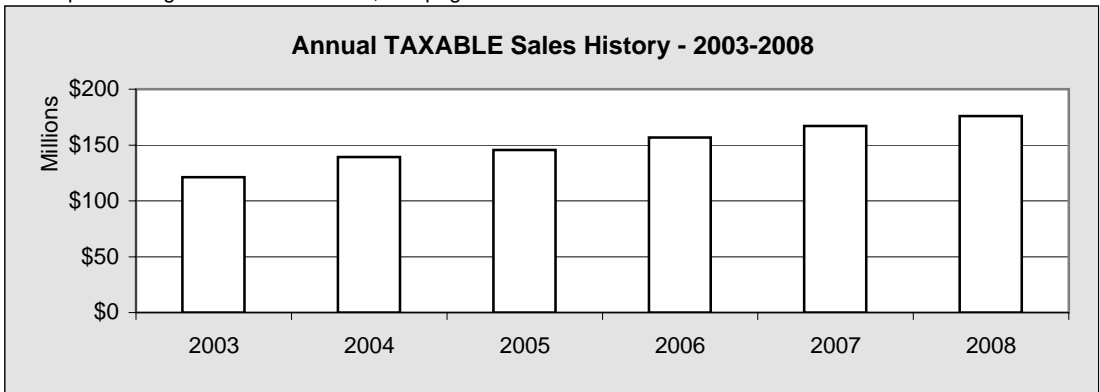
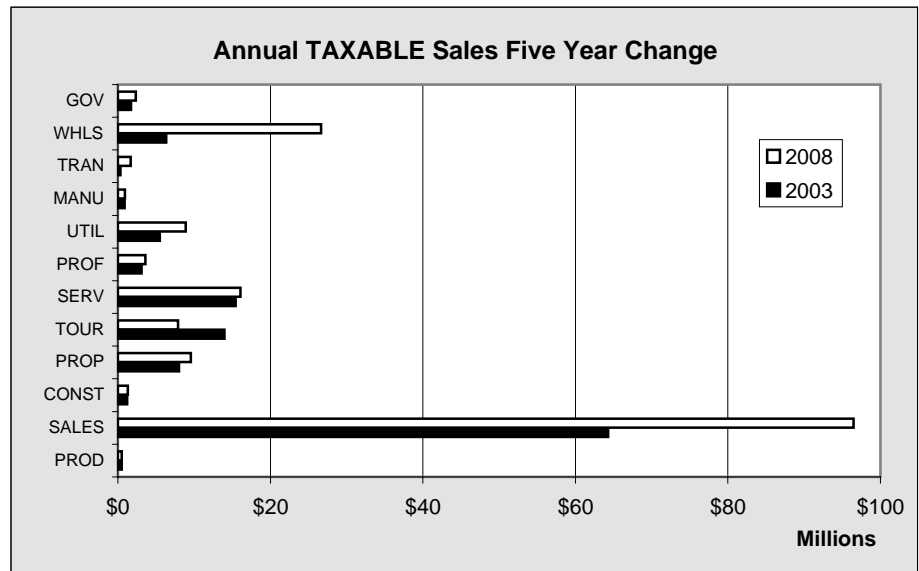

Chart 3.7

Five Year Change Annual TAXABLE Sales		
LOB	2003	2008
PROD	488,890	520,028
SALES	64,294,562	96,483,648
CONST	1,233,344	1,294,990
PROP	8,015,439	9,560,366
TOUR	13,961,938	7,872,506
SERV	15,434,023	16,054,477
PROF	3,090,294	3,607,232
UTIL	5,509,627	8,906,132
MANU	893,384	939,292
TRAN	318,401	1,665,116
WHLS	6,336,422	26,632,258
GOV	1,738,471	2,355,439
TOTAL	121,314,795	175,891,484

Table 3.12

Chart 3.8



Kenai Sales

Kenai GROSS Sales by Line of Business by Quarter - 2008 - in \$					
LOB	1st Quarter	2nd Quarter	3rd Quarter	4th Quarter	Total
Resource Production	6,141,814	7,935,421	6,061,323	40,401,576	60,540,134
Sales	27,518,789	33,718,890	40,914,680	37,596,782	139,749,141
Construction	3,881,416	14,056,938	22,533,375	14,736,790	55,208,519
Property	4,084,772	4,420,459	5,521,248	5,114,654	19,141,133
Tourism	1,182,510	2,270,197	3,920,553	1,387,162	8,760,422
Services	5,484,844	6,183,799	7,177,639	6,214,042	25,060,324
Professional	3,532,617	3,421,193	3,123,406	3,464,020	13,541,236
Utility	4,537,381	3,438,931	3,055,902	4,416,194	15,448,408
Manufacturing	5,392,390	6,451,944	21,998,896	4,267,509	38,110,739
Transportation & Warehousing	30,629,052	39,669,786	43,707,193	36,479,760	150,485,791
Wholesale	15,591,985	24,108,292	23,001,404	14,827,648	77,529,329
Government	834,505	904,613	1,472,864	889,398	4,101,380
TOTAL	108,812,075	146,580,463	182,488,483	169,795,535	607,676,556

Table 3.13

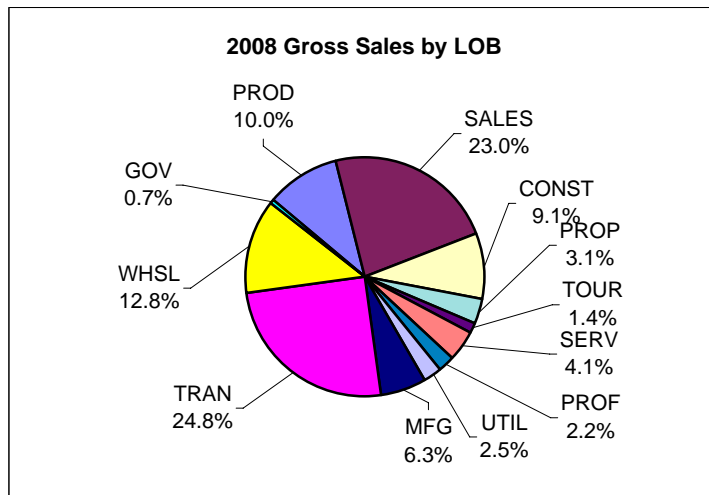

Chart 3.9

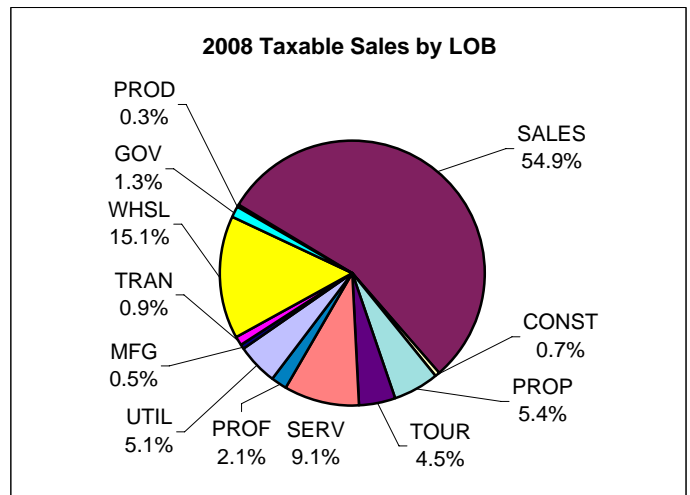

Chart 3.10

Kenai TAXABLE Sales by Line of Business by Quarter - 2008 - in \$					
LOB	1st Quarter	2nd Quarter	3rd Quarter	4th Quarter	Total
Resource Production	89,323	200,916	112,719	117,070	520,028
Sales	20,157,525	23,754,686	28,026,000	24,545,437	96,483,648
Construction	269,117	300,847	369,364	355,662	1,294,990
Property	1,979,140	2,083,451	3,000,345	2,497,430	9,560,366
Tourism	1,080,836	2,040,331	3,475,076	1,276,263	7,872,506
Services	3,654,531	4,051,203	4,471,949	3,876,794	16,054,477
Professional	1,048,424	951,266	790,579	816,963	3,607,232
Utility	2,803,047	2,014,942	1,593,826	2,494,317	8,906,132
Manufacturing	133,048	240,182	408,508	157,554	939,292
Transportation & Warehousing	232,760	448,028	581,714	402,614	1,665,116
Wholesale	4,238,859	8,249,920	8,716,428	5,427,051	26,632,258
Government	512,784	524,436	827,495	490,724	2,355,439
TOTAL	36,199,394	44,860,208	52,374,003	42,457,879	175,891,484

Table 3.14

Kenai Sales

Kenai GROSS Sales by Line of Business by Quarter - 2007 - in \$					
LOB	1st Quarter	2nd Quarter	3rd Quarter	4th Quarter	Total
Resource Production	655,921	2,562,639	3,927,205	39,570,701	2,365,868
Sales	25,489,855	31,101,820	34,116,919	31,883,757	105,875,605
Construction	4,581,023	7,351,945	13,301,420	8,775,677	42,882,913
Property	3,728,842	4,129,632	4,495,337	4,796,699	16,845,079
Tourism	3,165,712	4,525,506	6,738,567	3,751,224	39,520,368
Services	5,385,333	6,525,505	7,027,991	6,755,744	41,862,709
Professional	4,072,946	3,398,315	3,711,731	4,123,322	10,191,987
Utility	4,581,786	3,263,725	2,891,115	3,462,862	35,617,604
Manufacturing	4,547,604	5,843,067	19,102,878	3,194,710	7,469,355
Transportation & Warehousing	30,603,635	24,517,859	33,364,286	31,125,914	8,718,520
Wholesale	9,074,444	17,741,429	22,917,023	20,608,936	37,993,258
Government	791,264	998,930	1,401,362	872,957	4,108,884
TOTAL	96,678,365	111,960,372	152,995,834	158,922,503	520,557,074

Table 3.15

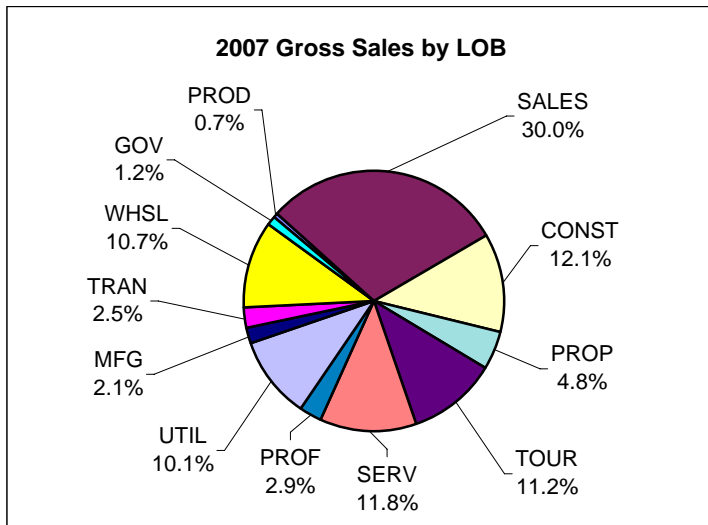

Chart 3.11

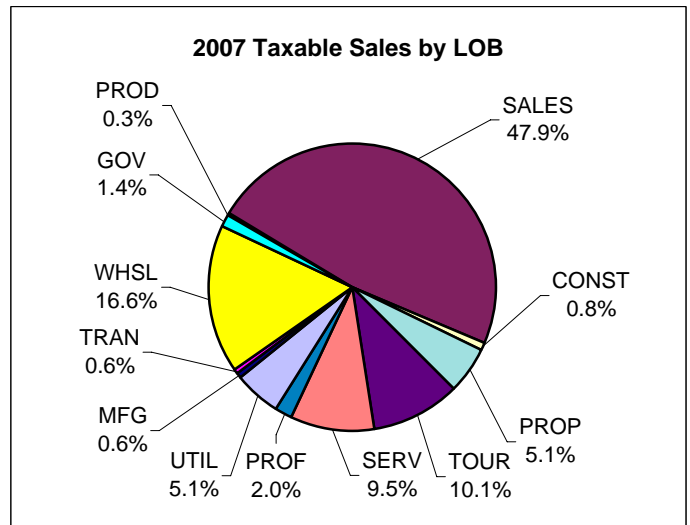

Chart 3.12

Kenai TAXABLE Sales by Line of Business by Quarter - 2007 - in \$					
LOB	1st Quarter	2nd Quarter	3rd Quarter	4th Quarter	Total
Resource Production	57,569	204,307	114,718	143,911	520,505
Sales	16,487,590	19,991,586	22,706,524	20,776,818	79,962,518
Construction	265,532	306,813	342,452	351,062	1,265,859
Property	1,947,916	2,094,540	2,298,849	2,250,573	8,591,878
Tourism	3,012,613	4,276,569	6,218,636	3,343,199	16,851,017
Services	3,510,801	4,084,453	4,379,319	3,953,409	15,927,982
Professional	991,605	871,047	722,766	703,472	3,288,890
Utility	2,879,713	2,035,875	1,498,109	2,052,263	8,465,960
Manufacturing	121,285	196,958	540,635	202,769	1,061,647
Transportation & Warehousing	121,148	322,108	289,404	230,080	962,740
Wholesale	4,422,724	8,166,287	8,633,646	6,582,845	27,805,502
Government	495,297	546,299	811,324	519,960	2,372,880
TOTAL	34,313,793	43,096,842	48,556,382	41,110,361	167,077,378

Table 3.16

Kenai Sales

Kenai GROSS Sales by Line of Business by Quarter - 2006 - in \$					
LOB	1st Quarter	2nd Quarter	3rd Quarter	4th Quarter	Total
Resource Production	1,097,363	1,728,194	1,298,983	39,163,292	43,287,832
Sales	25,915,409	36,764,509	32,609,317	28,854,426	124,143,661
Construction	1,688,153	5,495,891	8,251,063	25,445,821	40,880,928
Property	3,574,662	4,389,470	5,000,463	4,552,538	17,517,133
Tourism	3,223,682	4,740,375	7,098,168	3,658,481	18,720,706
Services	4,889,784	5,182,062	5,941,675	6,156,783	22,170,304
Professional	3,827,587	3,715,180	4,331,435	4,035,843	15,910,045
Utility	3,940,507	2,886,141	2,448,211	3,731,578	13,006,437
Manufacturing	2,523,764	5,782,515	14,371,206	6,528,995	29,206,480
Transportation & Warehousing	2,693,130	22,534,044	22,978,804	26,500,017	74,705,995
Wholesale	9,169,811	15,264,810	16,125,342	13,328,084	53,888,047
Government	729,788	795,527	1,083,271	885,890	3,494,476
TOTAL	63,273,640	109,278,718	121,537,938	162,841,748	456,932,044

Table 3.17

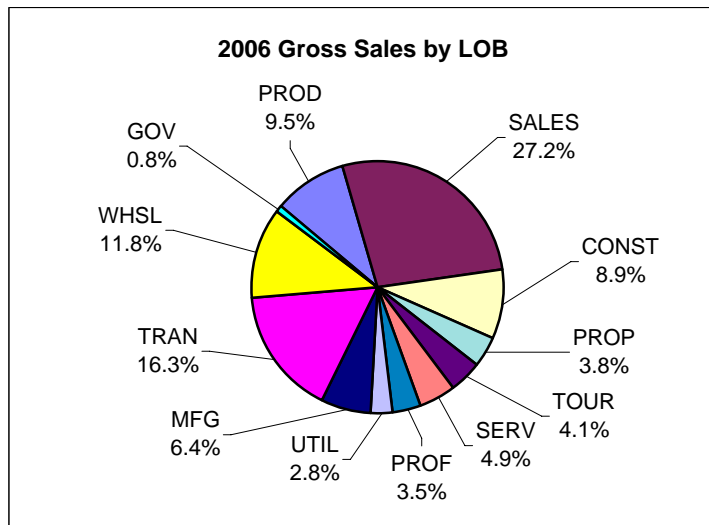

Chart 3.13

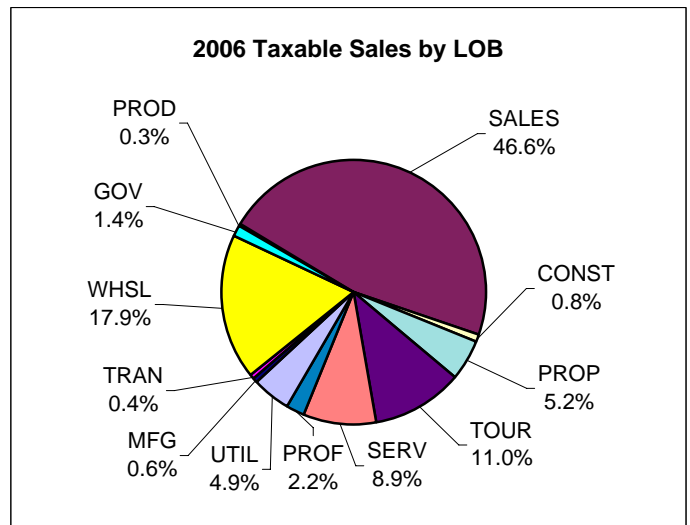

Chart 3.14

Kenai TAXABLE Sales by Line of Business by Quarter - 2006 - in \$					
LOB	1st Quarter	2nd Quarter	3rd Quarter	4th Quarter	Total
Resource Production	58,754	172,765	89,798	118,901	440,218
Sales	15,154,575	18,982,552	20,482,972	18,388,141	73,008,240
Construction	236,295	283,398	314,112	354,544	1,188,349
Property	1,799,840	1,983,465	2,245,207	2,087,621	8,116,133
Tourism	3,041,808	4,504,591	6,147,138	3,469,892	17,163,429
Services	3,243,948	3,338,675	3,689,853	3,603,418	13,875,894
Professional	1,000,733	974,676	806,633	696,078	3,478,120
Utility	2,403,379	1,749,039	1,304,520	2,148,120	7,605,058
Manufacturing	111,997	196,427	420,755	154,588	883,767
Transportation & Warehousing	134,030	204,251	221,909	110,137	670,327
Wholesale	4,737,150	8,203,295	8,793,332	6,316,534	28,050,311
Government	467,706	503,795	700,435	488,813	2,160,749
TOTAL	32,390,215	41,096,929	45,216,664	37,936,787	156,640,595

Table 3.18

Kenai Sales

Kenai Annual Gross Sales by Quarter - in \$						
	1st Quarter	2nd Quarter	3rd Quarter	4th Quarter	Total	Annual Change
1995	47,025,594	63,188,380	103,891,510	53,966,235	268,071,719	
1996	44,272,558	59,006,953	89,244,719	56,206,797	248,731,027	-7.2%
1997	46,734,219	69,543,282	92,318,998	69,499,878	278,096,377	11.8%
1998	57,398,212	69,795,945	85,276,693	67,609,090	280,079,940	0.7%
1999	49,309,897	61,601,436	91,868,389	67,946,601	270,726,323	-3.3%
2000	55,609,576	66,148,908	89,482,163	72,403,855	283,644,502	4.8%
2001	62,412,055	76,653,184	94,911,501	76,422,702	310,399,442	9.4%
2002	60,485,836	67,818,581	82,467,626	68,523,671	279,295,714	-10.0%
2003	62,037,733	67,206,051	81,150,318	72,488,393	282,882,495	1.3%
2004	61,072,504	80,377,589	97,860,387	167,961,695	407,272,175	44.0%
2005	75,641,521	102,543,222	112,340,508	175,254,701	465,779,952	14.4%
2006	63,273,640	109,278,718	121,537,938	162,841,748	456,932,044	-1.9%
2007	96,678,365	111,960,372	152,995,834	158,922,503	520,557,074	13.9%
2008	108,812,075	146,580,463	182,488,483	169,795,535	607,676,556	16.7%
Change	12.6%	30.9%	19.3%	6.8%	16.7%	

Table 3.19

Kenai Annual Taxable Sales by Quarter - in \$						
	1st Quarter	2nd Quarter	3rd Quarter	4th Quarter	Total	Annual Change
1995	22,806,366	28,328,016	32,447,853	28,983,412	112,565,647	
1996	23,821,757	29,825,649	33,254,658	29,649,466	116,551,530	3.5%
1997	23,734,621	30,223,772	34,152,494	30,465,867	118,576,754	1.7%
1998	24,686,791	30,026,162	33,360,588	31,957,166	120,030,707	1.2%
1999	25,183,897	30,901,457	34,547,855	33,714,087	124,347,296	3.6%
2000	25,521,513	31,538,250	36,610,960	34,057,441	127,728,164	2.7%
2001	27,883,010	34,967,917	38,162,815	36,003,199	137,016,941	7.3%
2002*	28,916,700	34,624,807	38,168,856	34,967,885	136,678,248	-0.2%
2003	31,093,476	29,801,554	31,351,738	29,068,027	121,314,795	-11.2%
2004	29,545,991	36,253,288	40,042,718	33,531,865	139,373,862	14.9%
2005	29,608,133	37,518,001	42,697,902	35,712,018	145,536,054	4.4%
2006	32,390,215	41,096,929	45,216,664	37,936,787	156,640,595	7.6%
2007	34,313,793	43,096,842	48,556,382	41,110,361	167,077,378	6.7%
2008	36,199,394	44,860,208	52,374,003	42,457,879	175,891,484	5.3%
Change	5.5%	4.1%	7.9%	3.3%	5.3%	

Table 3.20

Kenai Annual Non-Taxable Sales by Quarter - in \$						
	1st Quarter	2nd Quarter	3rd Quarter	4th Quarter	Total	Annual Change
1995	24,219,228	34,860,364	71,443,657	24,982,823	155,506,072	
1996	20,450,801	29,181,304	55,990,061	26,557,331	132,179,497	-15.0%
1997	22,999,598	39,319,510	58,166,504	39,034,011	159,519,623	20.7%
1998	32,711,421	39,769,783	51,916,105	35,651,924	160,049,233	0.3%
1999	24,126,000	30,699,979	57,320,534	34,232,514	146,379,027	-8.5%
2000	30,088,063	34,610,658	52,871,203	38,346,414	155,916,338	6.5%
2001	34,529,045	41,685,267	56,748,686	40,419,503	173,382,501	11.2%
2002*	31,569,136	33,193,774	44,298,770	33,555,786	142,617,466	-17.7%
2003	30,944,257	37,404,497	49,798,580	43,420,366	161,567,700	13.3%
2004	31,526,513	44,124,301	57,817,669	134,429,830	267,898,313	65.8%
2005	46,033,388	65,025,221	69,642,606	139,542,683	320,243,898	19.5%
2006	30,883,425	68,181,789	76,321,274	124,904,961	300,291,449	-6.2%
2007	62,364,572	68,863,530	104,439,452	117,812,142	353,479,696	17.7%
2008	72,612,681	101,720,255	130,114,480	127,337,656	431,785,072	22.2%
Change	16.4%	47.7%	24.6%	8.1%	22.2%	

Table 3.21

Kenai Construction Permits

Kenai 4th Quarter Permit VALUES by Type - 2002-2008 - in

	2002	2003	2004	2005	2006	2007	2008	Annual Change
Residential New	377,000	779,000	482,000	946,000	1,334,000	0	730,875	NA
Residential Alter/Add	70,000	183,000	27,000	78,500	26,700	32,700	182,000	456.6%
Commercial New	990,000	253,000	0	128,000	375,000	0	60,000	NA
Commercial Alter/Add	90,800	1,240,500	76,400	67,500	52,200	407,000	493,000	0.0%
Total	1,527,800	2,455,500	585,400	1,220,000	1,787,900	439,700	1,465,875	233.4%
Annual Change		60.7%	-76.2%	108.4%	46.5%	-75.4%	233.4%	

Table 3.22

Kenai 4th Quarter Permit VALUES by Type - 1986-2008

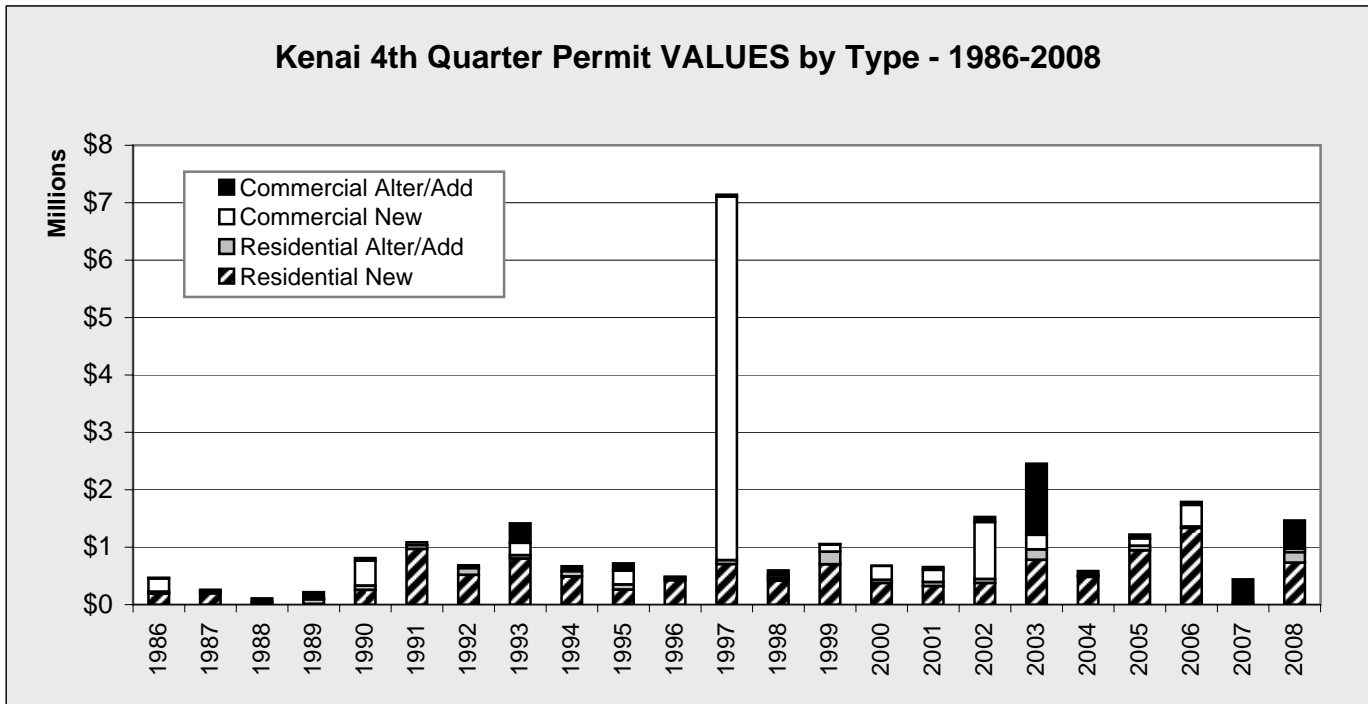

Chart 3.15

**Kenai 4th Quarter Permit VALUES
Percent by Type - 2008**

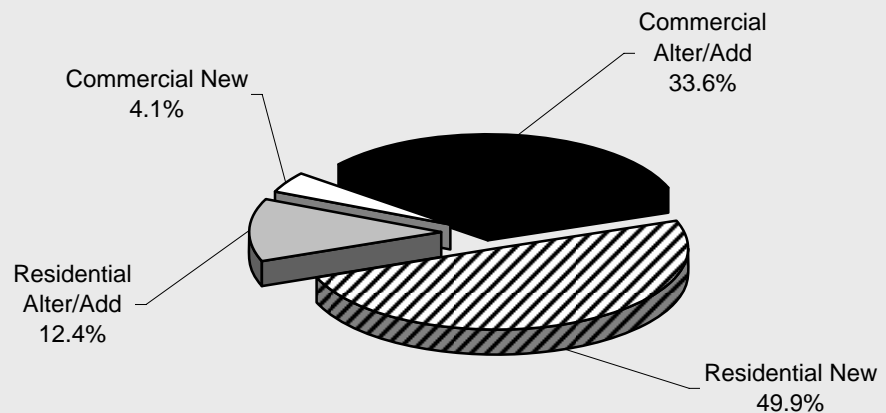

Chart 3.16

Kenai Construction Permits

Kenai 4th Quarter Permit VOLUME by Type - 2002-2008								
	2002	2003	2004	2005	2006	2007	2008	Annual Change
Residential New	3	6	4	5	5	0	4	NA
Residential Alter/Add	4	5	4	4	4	7	5	-28.6%
Commercial New	3	2	0	1	1	0	1	NA
Commercial Alter/Add	10	8	6	4	4	7	5	-28.6%
Total	20	21	14	14	14	14	15	7.1%
Annual Change		5.0%	-33.3%	0.0%	0.0%	0.0%	7.1%	

Table 3.23

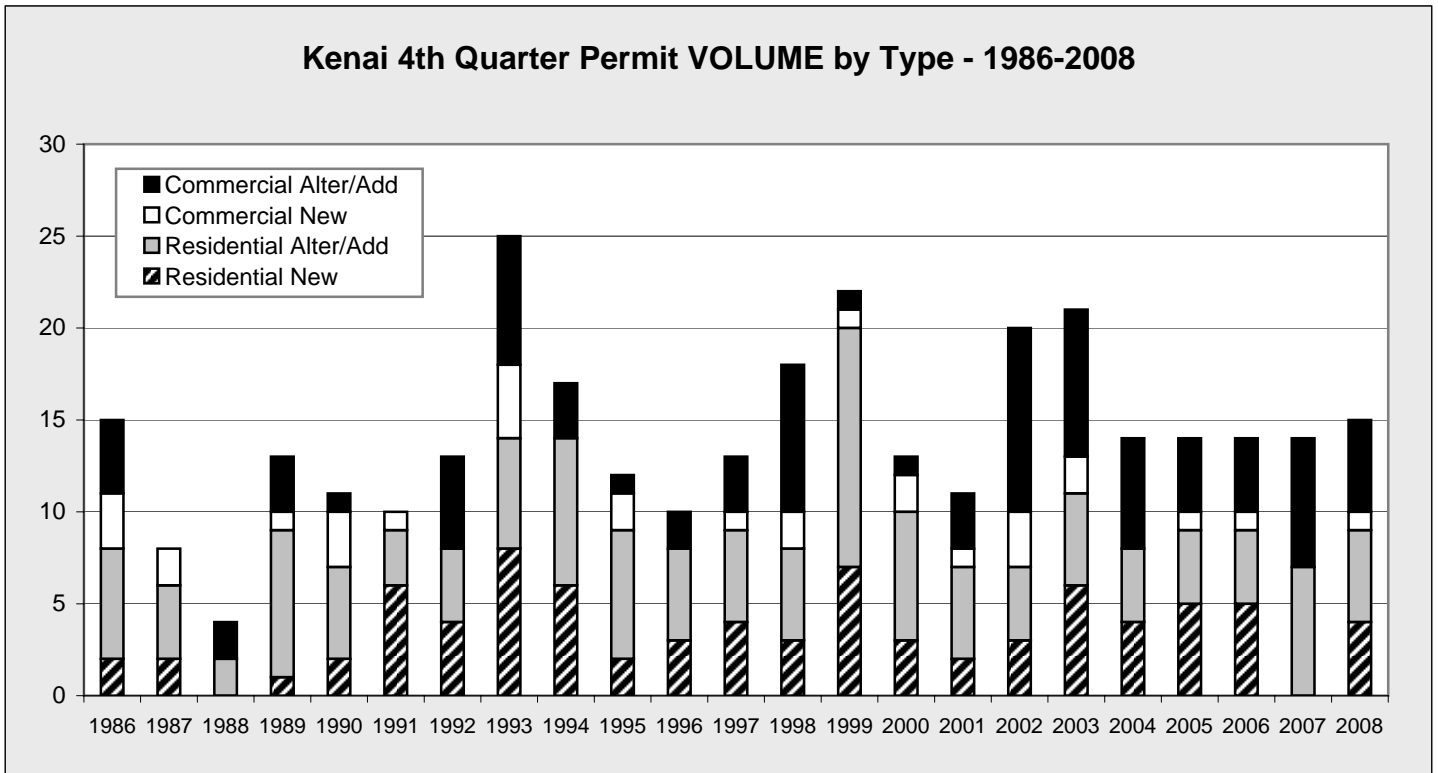

Chart 3.17

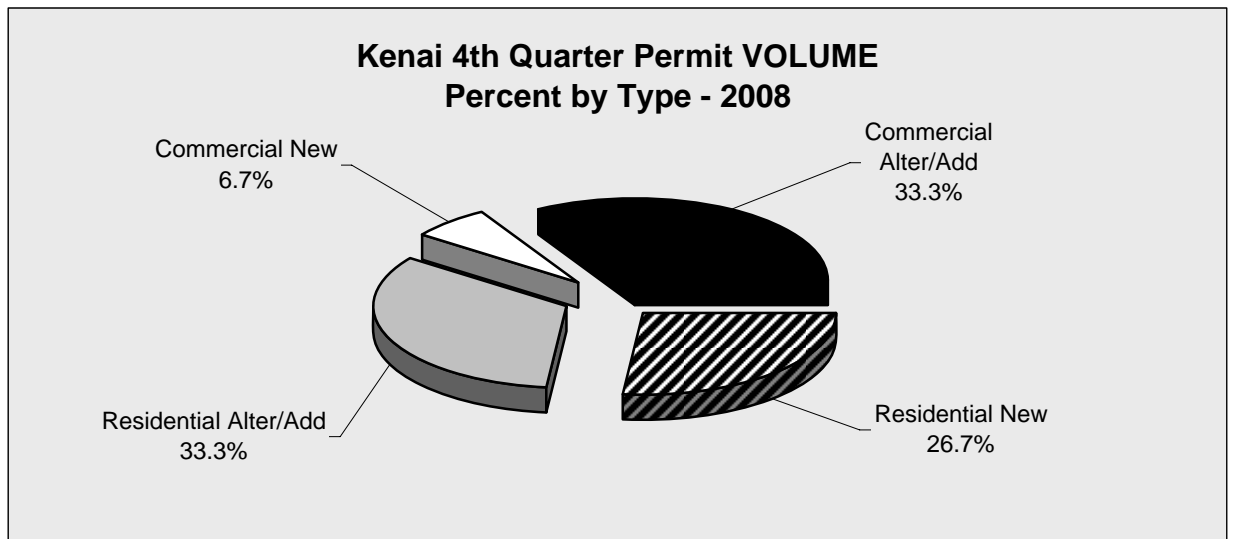

Chart 3.18

Kenai Construction Permits

Kenai Annual Permit VALUES by Type - 2002-2008 - in \$								
	2002	2003	2004	2005	2006	2007	2008	Annual Change
Residential New	5,917,000	3,282,000	3,058,500	4,373,500	7,419,500	5,708,500	5,061,375	-11.3%
Residential Alter/Add	723,500	882,050	400,150	650,900	628,554	1,501,300	821,400	-45.3%
Commercial New	6,261,200	304,000	331,000	1,173,000	610,000	7,364,000	37,071,100	403.4%
Commercial Alter/Add	3,897,700	5,973,750	996,900	2,040,500	2,418,100	7,824,200	3,532,500	-54.9%
Total	16,799,400	10,441,800	4,786,550	8,237,900	11,076,154	22,398,000	46,486,375	107.5%
Annual Change		-37.8%	-54.2%	72.1%	34.5%	102.2%	107.5%	

Table 3.24

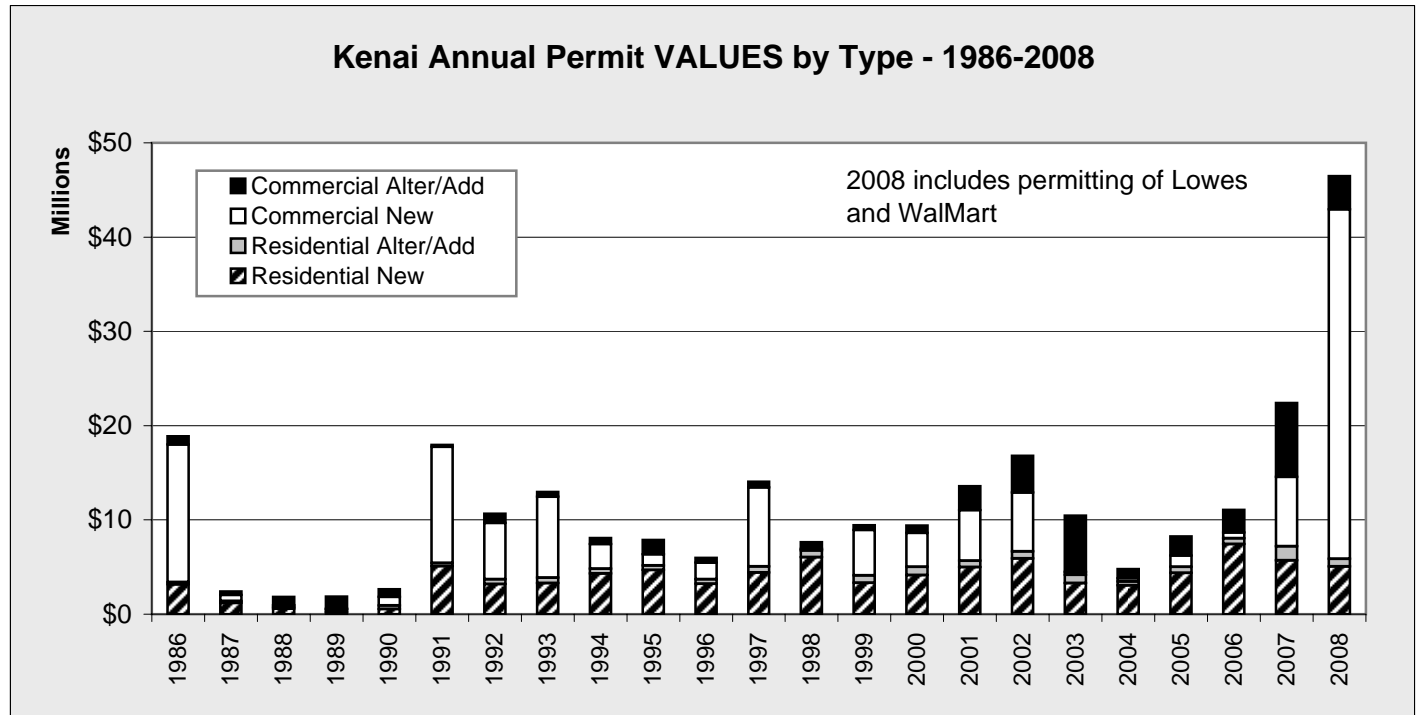

Chart 3.19

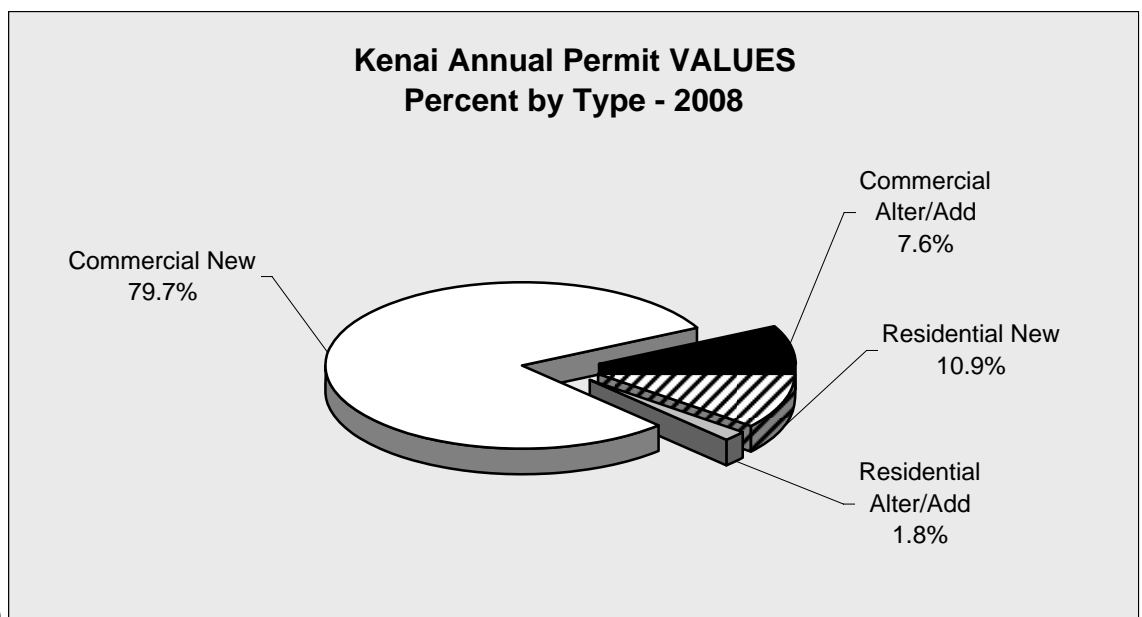

Chart 3.20

Kenai Construction Permits

Kenai Annual Permit VOLUME by Type - 2002-2008								
	2002	2003	2004	2005	2006	2007	2008	Annual Change
Residential New	42	22	20	24	37	33	25	-24.2%
Residential Alter/Add	45	44	25	36	39	51	45	-11.8%
Commercial New	9	4	3	4	3	6	7	16.7%
Commercial Alter/Add	25	44	31	26	34	22	37	68.2%
Total	121	114	79	90	113	112	114	1.8%
Annual Change		-5.8%	-30.7%	13.9%	25.6%	-0.9%	1.8%	

Table 3.25

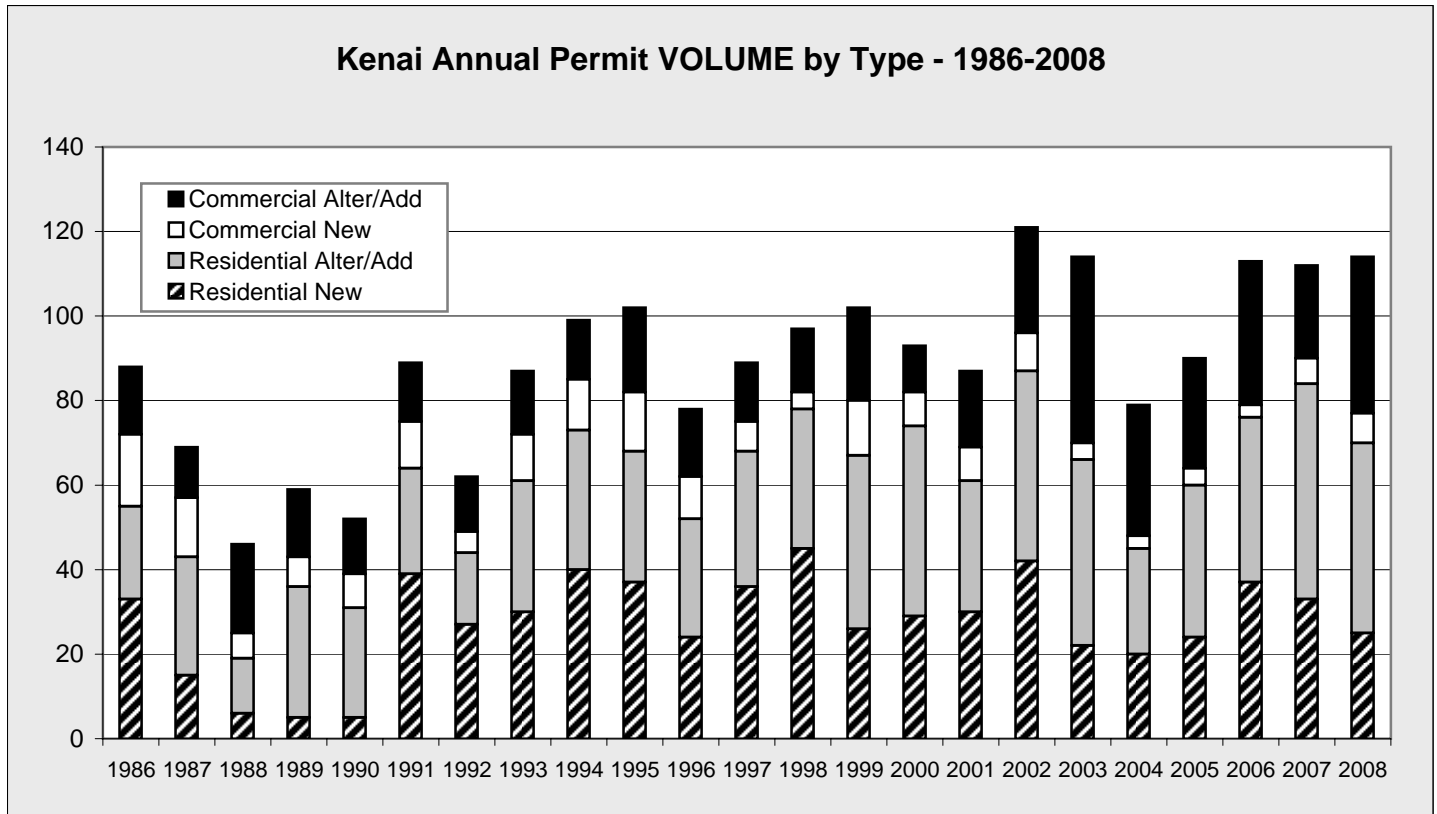

Chart 3.21

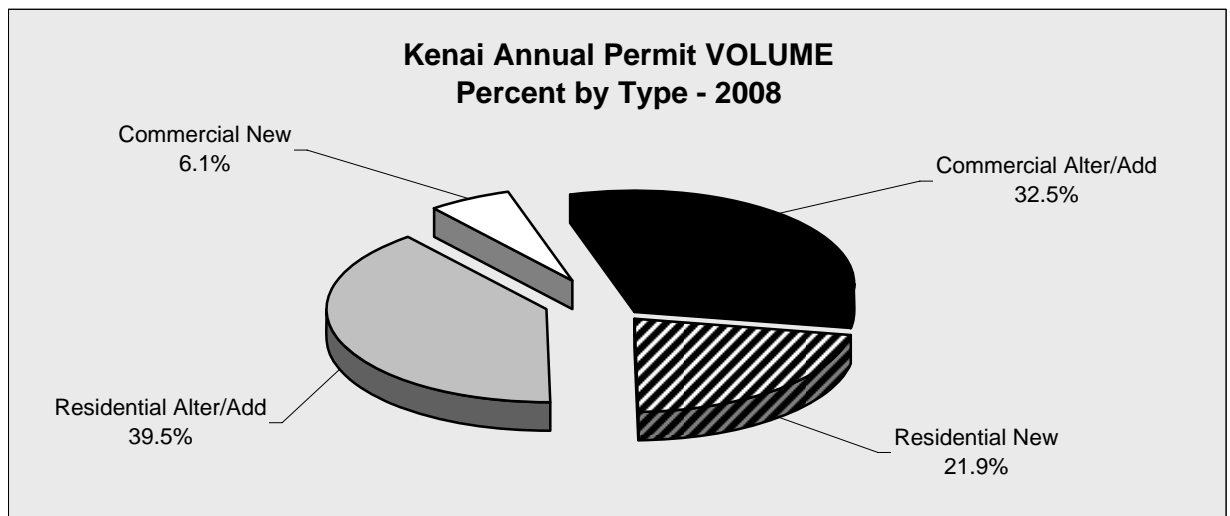

Chart 3.22

Kenai Construction Permits

Kenai Annual Permit VALUE by Type by Quarter - 2001-2008 - in \$					
	1st Quarter	2nd Quarter	3rd Quarter	4th Quarter	Total
2001					
Residential - New	623,000	2,886,000	1,152,000	324,000	4,985,000
Residential - Add/Alter	161,500	228,300	217,500	67,800	675,100
Commercial - New	15,000	3,744,000	1,406,700	214,000	5,379,700
Commercial - Add/Alter	20,000	739,600	1,730,000	49,500	2,539,100
TOTAL	819,500	7,597,900	4,506,200	655,300	13,578,900
2002					
Residential - New	279,000	2,362,000	2,899,000	377,000	5,917,000
Residential - Add/Alter	28,000	323,100	302,400	70,000	723,500
Commercial - New	3,579,200	1,480,000	212,000	990,000	6,261,200
Commercial - Add/Alter	2,000	404,300	3,400,600	90,800	3,897,700
TOTAL	3,888,200	4,569,400	6,814,000	1,527,800	16,799,400
2003					
Residential - New	0	1,943,000	560,000	779,000	3,282,000
Residential - Add/Alter	15,000	515,200	168,850	183,000	882,050
Commercial - New	0	0	51,000	253,000	304,000
Commercial - Add/Alter	1,542,600	270,150	2,920,500	1,240,500	5,973,750
TOTAL	1,557,600	2,728,350	3,700,350	2,455,500	10,441,800
2004					
Residential - New	300,000	1,079,000	1,197,500	482,000	3,058,500
Residential - Add/Alter	12,000	52,200	308,950	27,000	400,150
Commercial - New	0	81,000	250,000	0	331,000
Commercial - Add/Alter	0	685,200	235,300	76,400	996,900
TOTAL	312,000	1,897,400	1,991,750	585,400	4,786,550
2005					
Residential - New	0	1,883,500	1,544,000	946,000	4,373,500
Residential - Add/Alter	134,500	131,300	306,600	78,500	650,900
Commercial - New	0	45,000	1,000,000	128,000	1,173,000
Commercial - Add/Alter	291,000	497,500	1,184,500	67,500	2,040,500
TOTAL	425,500	2,557,300	4,035,100	1,220,000	8,237,900
2006					
Residential - New	378,000	3,383,000	2,324,500	1,334,000	7,419,500
Residential - Add/Alter	34,000	305,700	262,154	26,700	628,554
Commercial - New	0	60,000	175,000	375,000	610,000
Commercial - Add/Alter	351,500	408,400	1,606,000	52,200	2,418,100
TOTAL	763,500	4,157,100	4,367,654	1,787,900	11,076,154
2007					
Residential - New	527,000	3,934,500	1,247,000	0	5,708,500
Residential - Add/Alter	144,000	706,900	617,700	32,700	1,501,300
Commercial - New	0	889,000	6,475,000	0	7,364,000
Commercial - Add/Alter	98,500	637,700	6,681,000	407,000	7,824,200
TOTAL	769,500	6,168,100	15,020,700	439,700	22,398,000
2008					
Residential - New	0	2,432,000	1,898,500	730,875	5,061,375
Residential - Add/Alter	65,000	309,300	265,100	182,000	821,400
Commercial - New	0	14,746,100	22,265,000	60,000	37,071,100
Commercial - Add/Alter	998,300	1,493,500	547,700	493,000	3,532,500
TOTAL	1,063,300	18,980,900	24,976,300	1,465,875	46,486,375

Table 3.26

Kenai Construction Permits

Kenai Annual Permit VOLUME by Type by Quarter - 2001-2008					
	1st Quarter	2nd Quarter	3rd Quarter	4th Quarter	Total
2001					
Residential - New	4	16	8	2	30
Residential - Add/Alter	5	13	8	5	31
Commercial - New	1	3	3	1	8
Commercial - Add/Alter	1	10	4	3	18
TOTAL	11	42	23	11	87
2002					
Residential - New	2	18	19	3	42
Residential - Add/Alter	1	14	26	4	45
Commercial - New	1	3	2	3	9
Commercial - Add/Alter	1	2	12	10	25
TOTAL	5	37	59	20	121
2003					
Residential - New	0	13	3	6	22
Residential - Add/Alter	1	16	22	5	44
Commercial - New	0	0	2	2	4
Commercial - Add/Alter	7	11	18	8	44
TOTAL	8	40	45	21	114
2004					
Residential - New	3	5	8	4	20
Residential - Add/Alter	1	8	12	4	25
Commercial - New	0	2	1	0	3
Commercial - Add/Alter	0	15	10	6	31
TOTAL	4	30	31	14	79
2005					
Residential - New	0	11	8	5	24
Residential - Add/Alter	7	11	14	4	36
Commercial - New	0	2	1	1	4
Commercial - Add/Alter	3	9	10	4	26
TOTAL	10	33	33	14	90
2006					
Residential - New	2	16	14	5	37
Residential - Add/Alter	3	16	16	4	39
Commercial - New	0	1	1	1	3
Commercial - Add/Alter	9	9	12	4	34
TOTAL	14	42	43	14	113
2007					
Residential - New	4	17	12	0	33
Residential - Add/Alter	5	15	24	7	51
Commercial - New	0	2	4	0	6
Commercial - Add/Alter	2	9	4	7	22
TOTAL	11	43	44	14	112
2008					
Residential - New	0	10	11	4	25
Residential - Add/Alter	3	17	20	5	45
Commercial - New	0	3	3	1	7
Commercial - Add/Alter	9	15	8	5	37
TOTAL	12	45	42	15	114

Table 3.27

Seldovia Sales

Seldovia Fourth Quarter GROSS Sales by Line of Business - 2003-2008 - in \$								
LOB	2003	2004	2005	2006	2007	2008	Annual Percent Change	Annual Amount Change
PROD	0	0	0	0	0	0	0.0%	0
SALES	206,434	195,211	172,271	170,254	200,053	305,659	52.8%	105,606
CONST	738,842	706,248	130,496	156,311	1,852,198	782,433	-57.8%	-1,069,765
PROP	264,243	1,428,624	135,368	63,355	58,943	31,096	-47.2%	-27,847
TOUR	102,387	158,101	114,688	139,161	177,373	14,268	-92.0%	-163,105
SERV	105,846	78,896	98,867	97,459	151,394	193,025	27.5%	41,631
PROF	80,811	64,997	13,056	115,693	144,461	8,857	-93.9%	-135,604
UTIL	87,134	80,244	92,681	121,920	113,235	149,667	32.2%	36,432
MANU	95	2,667	902	0	2,589	17,684	583.0%	15,095
TRAN	0	0	5,730	6,215	7,741	450	-94.2%	-7,291
WHLS	295,192	356,839	365,097	389,339	563,842	475,252	-15.7%	-88,590
GOV	68,325	72,220	84,519	87,497	79,905	97,313	21.8%	17,408
TOTAL	1,949,309	3,144,047	1,213,675	1,347,204	3,351,734	2,075,704	-38.1%	-1,276,030

Table 4.1

For complete listing of Lines of Business, see page 13

Fourth Quarter GROSS Sales History	
2003	1,949,309
2004	3,144,047
2005	1,213,675
2006	1,347,204
2007	3,351,734
2008	2,075,704

Table 4.2

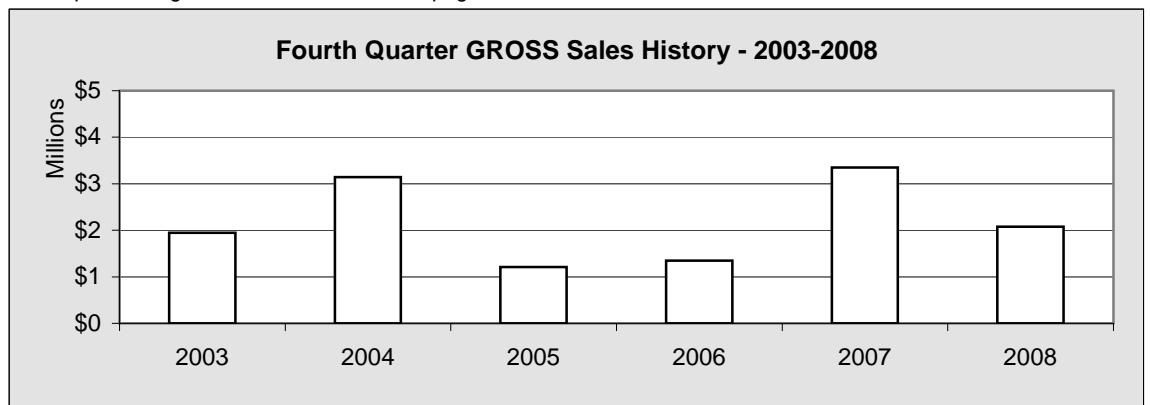

Chart 4.1

Five Year Change Fourth Quarter GROSS Sales		
	2003	2008
PROD	0	0
SALES	206,434	305,659
CONST	738,842	782,433
PROP	264,243	31,096
TOUR	102,387	14,268
SERV	105,846	193,025
PROF	80,811	8,857
UTIL	87,134	149,667
MANU	95	17,684
TRAN	0	450
WHLS	295,192	475,252
GOV	68,325	97,313
TOTAL	1,949,309	2,075,704

Table 4.3

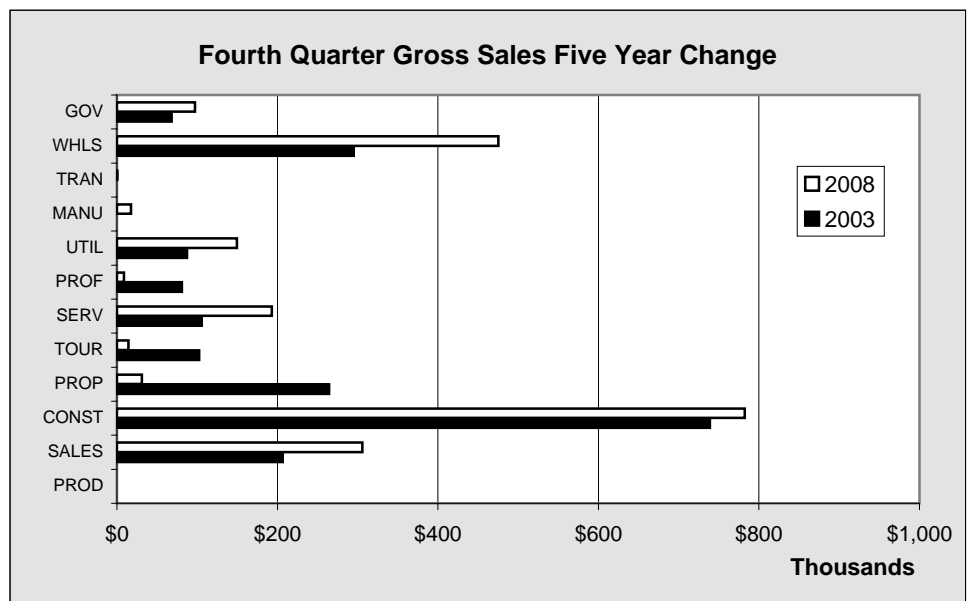

Chart 4.2

Seldovia Sales

Seldovia Fourth Quarter TAXABLE Sales by Line of Business - 2003-2008 - in \$								
LOB	2003	2004	2005	2006	2007	2008	Annual Percent Change	Annual Amount Change
PROD	0	0	0	0	0	0	0.0%	0
SALES	176,680	163,534	150,159	150,789	179,849	275,210	53.0%	95,361
CONST	9,371	6,350	9,132	7,079	17,941	15,181	-15.4%	-2,760
PROP	10,953	24,742	12,436	37,667	19,467	25,462	30.8%	5,995
TOUR	95,747	146,946	101,588	110,318	158,641	4,944	-96.9%	-153,697
SERV	96,790	55,498	74,243	73,256	83,572	160,192	91.7%	76,620
PROF	2,350	6,973	8,659	20,167	8,188	5,653	-31.0%	-2,535
UTIL	48,652	43,696	54,603	70,390	64,014	79,195	23.7%	15,181
MANU	0	2,079	102	0	1,057	520	-50.8%	-537
TRAN	0	0	130	239	0	0	0.0%	0
WHLS	165,821	184,328	198,130	188,842	247,292	239,474	-3.2%	-7,818
GOV	68,325	63,713	50,964	53,075	52,194	51,402	-1.5%	-792
TOTAL	674,689	697,859	660,146	711,822	832,215	857,233	3.0%	25,018

Table 4.4 For complete listing of Lines of Business, see page 13

Fourth Quarter TAXABLE Sales	
2003	674,689
2004	697,859
2005	660,146
2006	711,822
2007	832,215
2008	857,233

Table 4.5

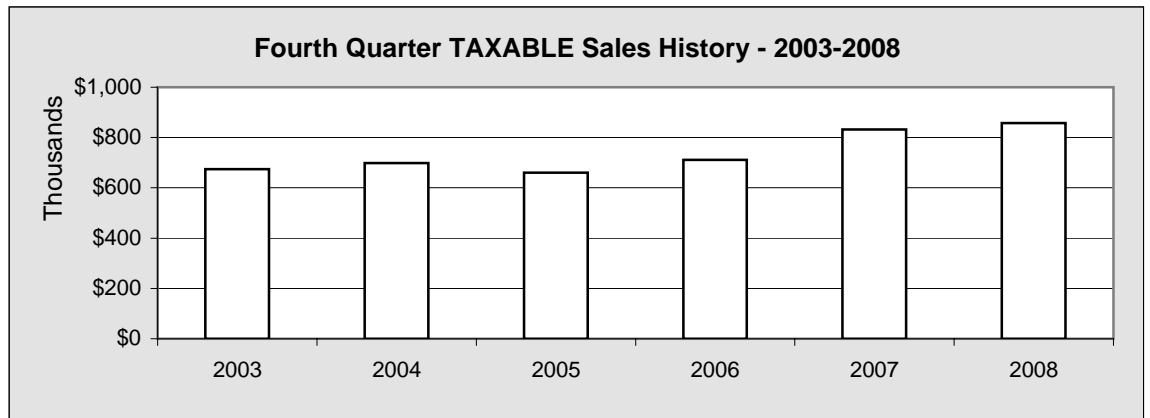
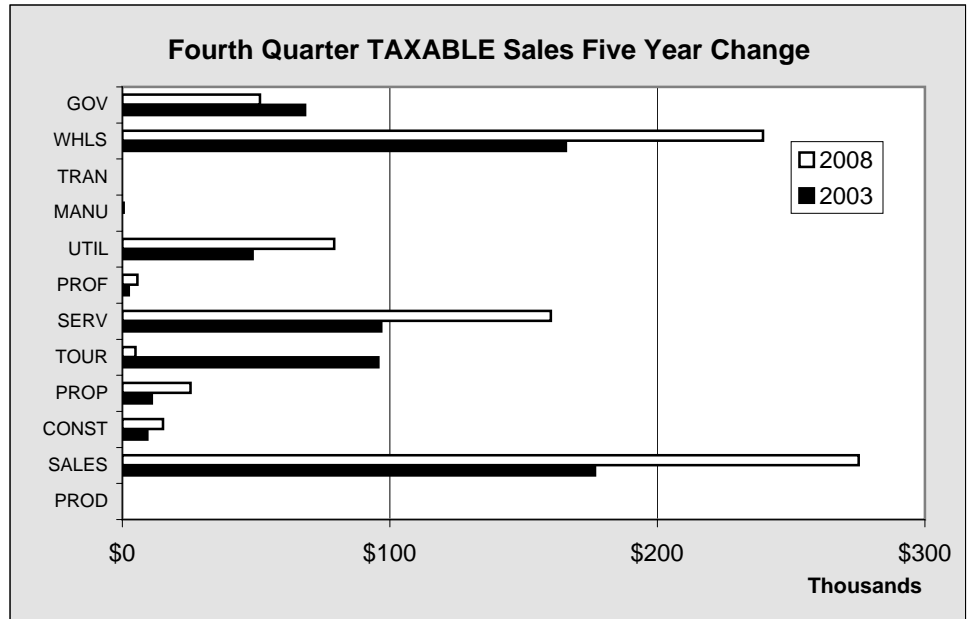

Chart 4.3

Five Year Change Fourth Quarter TAXABLE Sales		
LOB	2003	2008
PROD	0	0
SALES	176,680	275,210
CONST	9,371	15,181
PROP	10,953	25,462
TOUR	95,747	4,944
SERV	96,790	160,192
PROF	2,350	5,653
UTIL	48,652	79,195
MANU	0	520
TRAN	0	0
WHLS	165,821	239,474
GOV	68,325	51,402
TOTAL	674,689	857,233

Table 4.6

Chart 4.4



Seldovia Sales

Seldovia Annual GROSS Sales by Line of Business - 2003-2008 - in \$								
LOB	2003	2004	2005	2006	2007	2008	Annual Percent Change	Annual Amount Change
PROD	0	0	0	0	17	5,674	33276.5%	5,657
SALES	991,702	996,391	864,093	847,735	992,497	1,682,204	69.5%	689,707
CONST	2,241,387	2,431,728	1,482,392	1,030,138	2,962,633	1,723,873	-41.8%	-1,238,760
PROP	621,229	1,463,127	807,564	1,316,210	107,803	126,064	16.9%	18,261
TOUR	1,087,650	1,040,760	1,125,917	1,289,981	1,548,344	1,168,012	-24.6%	-380,332
SERV	298,639	344,487	349,754	406,193	671,443	669,621	-0.3%	-1,822
PROF	202,623	92,455	41,328	156,476	435,582	86,228	-80.2%	-349,354
UTIL	356,192	329,763	371,471	434,916	458,186	506,228	10.5%	48,042
MANU	8,028	23,842	24,294	12,259	11,163	31,677	183.8%	20,514
TRAN	1,824	0	7,314	69,793	19,151	8,374	-56.3%	-10,777
WHLS	1,174,485	1,306,023	1,486,381	1,598,598	1,921,275	2,086,580	8.6%	165,305
GOV	275,795	301,255	310,771	402,424	367,721	436,246	18.6%	68,525
TOTAL	7,259,554	8,329,831	6,871,279	7,564,723	9,495,815	8,530,781	-10.2%	-965,034

Table 4.7

For complete listing of Lines of Business, see page 13

Seldovia Annual GROSS Sales	
2003	7,259,554
2004	8,329,831
2005	6,871,279
2006	7,564,723
2007	9,495,815
2008	8,530,781

Table 4.8

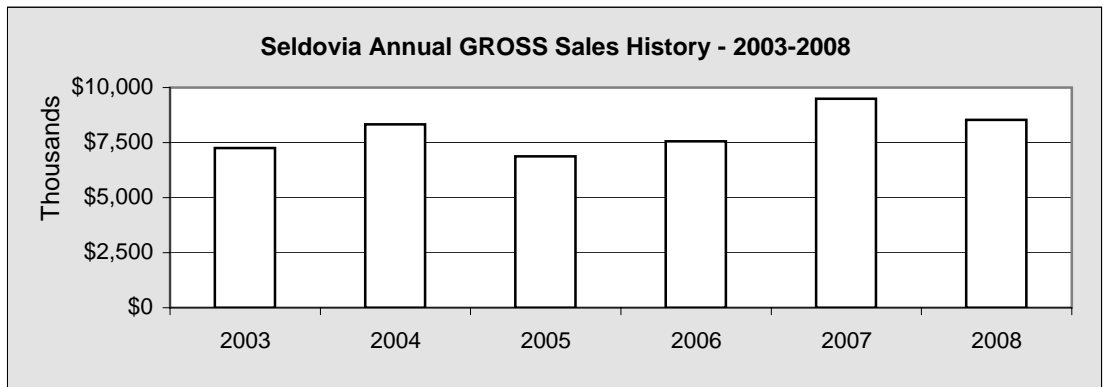

Chart 4.5

Five Year Change Annual GROSS Sales		
LOB	2003	2008
PROD	0	5,674
SALES	991,702	1,682,204
CONST	2,241,387	1,723,873
PROP	621,229	126,064
TOUR	1,087,650	1,168,012
SERV	298,639	669,621
PROF	202,623	86,228
UTIL	356,192	506,228
MANU	8,028	31,677
TRAN	1,824	8,374
WHLS	1,174,485	2,086,580
GOV	275,795	436,246
TOTAL	7,259,554	8,530,781

Table 4.9

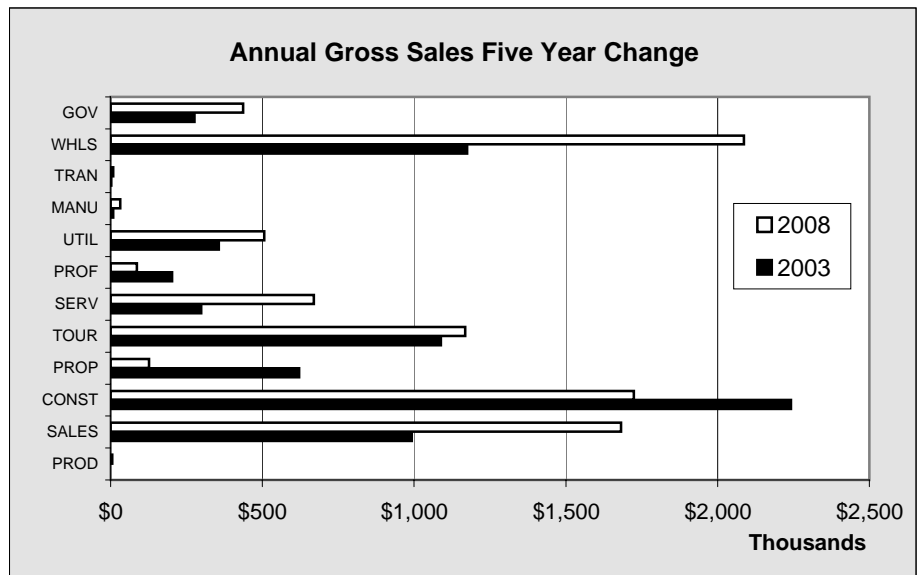

Chart 4.6

Seldovia Sales

Seldovia Annual TAXABLE Sales by Line of Business - 2003-2008 - in \$								
LOB	2003	2004	2005	2006	2007	2008	Annual Percent Change	Annual Amount Change
PROD	0	0	0	0	16	1,000	6150.0%	984
SALES	835,001	861,880	765,273	749,570	896,419	1,574,800	75.7%	678,381
CONST	29,348	26,204	29,768	34,880	40,834	58,927	44.3%	18,093
PROP	39,505	50,572	46,686	68,365	43,656	67,958	55.7%	24,302
TOUR	970,892	895,481	936,237	1,030,719	1,225,230	1,053,131	-14.0%	-172,099
SERV	258,334	231,604	239,046	278,269	459,263	461,563	0.5%	2,300
PROF	17,327	23,318	24,178	49,089	45,326	36,711	-19.0%	-8,615
UTIL	205,561	195,100	217,984	252,209	265,598	278,893	5.0%	13,295
MANU	2,027	8,636	8,788	3,230	3,849	6,015	56.3%	2,166
TRAN	837	0	1,216	1,962	1,061	1,415	33.4%	354
WHLS	766,780	856,967	880,245	930,613	1,055,721	1,168,921	10.7%	113,200
GOV	251,332	236,550	231,559	272,173	280,755	295,542	5.3%	14,787
TOTAL	3,376,944	3,386,312	3,380,980	3,671,079	4,317,728	5,004,876	15.9%	687,148

Table 4.10

For complete listing of Lines of Business, see page 13

Annual TAXABLE Sales History	
2003	3,376,944
2004	3,386,312
2005	3,380,980
2006	3,671,079
2007	4,317,728
2008	5,004,876

Table 4.11

Chart 4.7

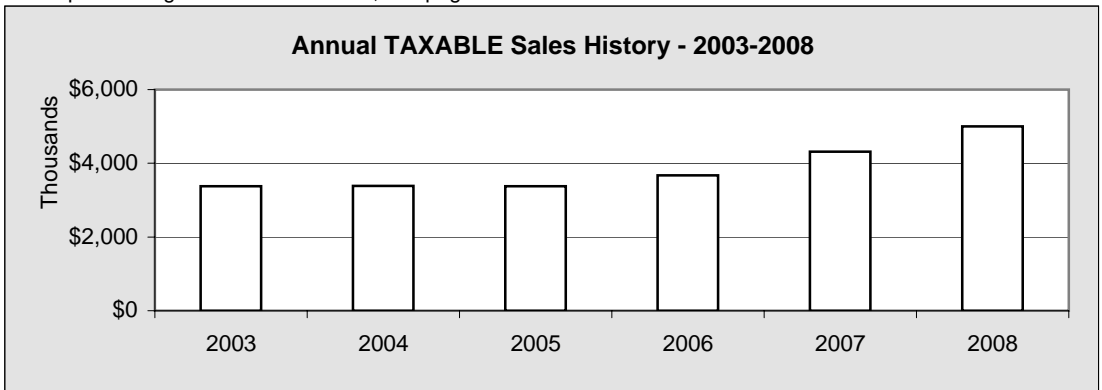

Five Year Change Annual TAXABLE Sales		
LOB	2003	2008
PROD	0	1,000
SALES	835,001	1,574,800
CONST	29,348	58,927
PROP	39,505	67,958
TOUR	970,892	1,053,131
SERV	258,334	461,563
PROF	17,327	36,711
UTIL	205,561	278,893
MANU	2,027	6,015
TRAN	837	1,415
WHLS	766,780	1,168,921
GOV	251,332	295,542
TOTAL	3,376,944	5,004,876

Table 4.12

Chart 4.8

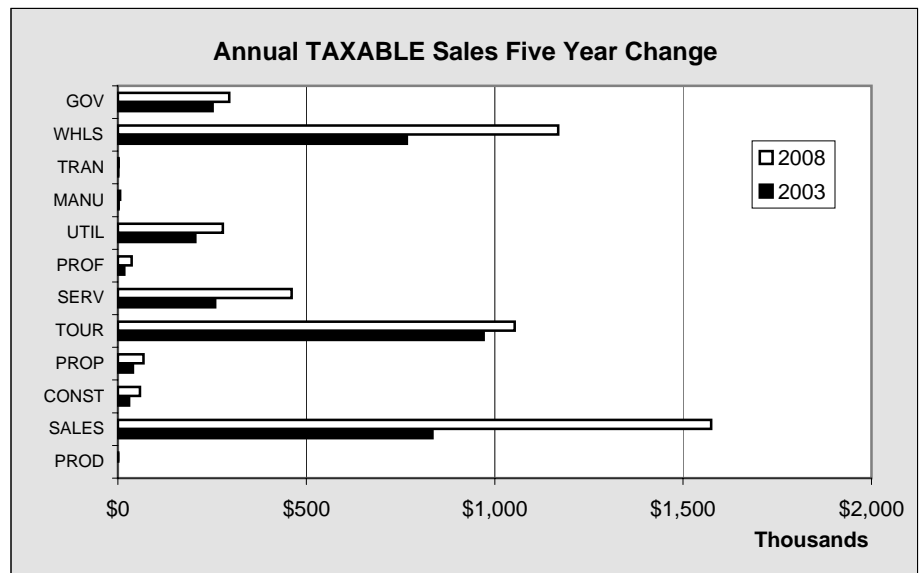

Seldovia Sales

Seldovia GROSS Sales by Line of Business by Quarter - 2008 - in \$					
LOB	1st Quarter	2nd Quarter	3rd Quarter	4th Quarter	Total
Resource Production	0	0	5,674	0	5,674
Sales	264,462	512,656	599,427	305,659	1,682,204
Construction	192,856	413,111	335,473	782,433	1,723,873
Property	19,351	38,899	36,718	31,096	126,064
Tourism	115,750	682,168	355,826	14,268	1,168,012
Services	124,481	136,079	216,036	193,025	669,621
Professional	46,815	10,105	20,451	8,857	86,228
Utility	122,500	120,070	113,991	149,667	506,228
Manufacturing	5,008	2,236	6,749	17,684	31,677
Transportation & Warehousing	0	1,629	6,295	450	8,374
Wholesale	485,090	567,188	559,050	475,252	2,086,580
Government	139,938	107,524	91,471	97,313	436,246
TOTAL	1,516,251	2,591,665	2,347,161	2,075,704	8,530,781

Table 4.13

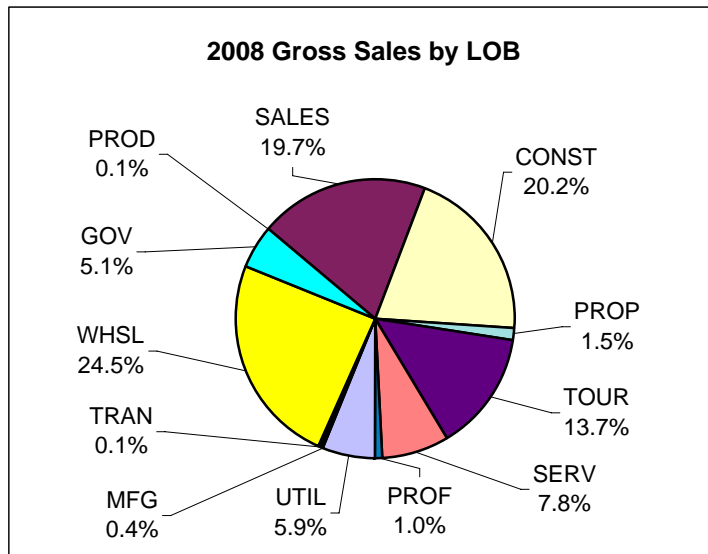

Chart 4.9

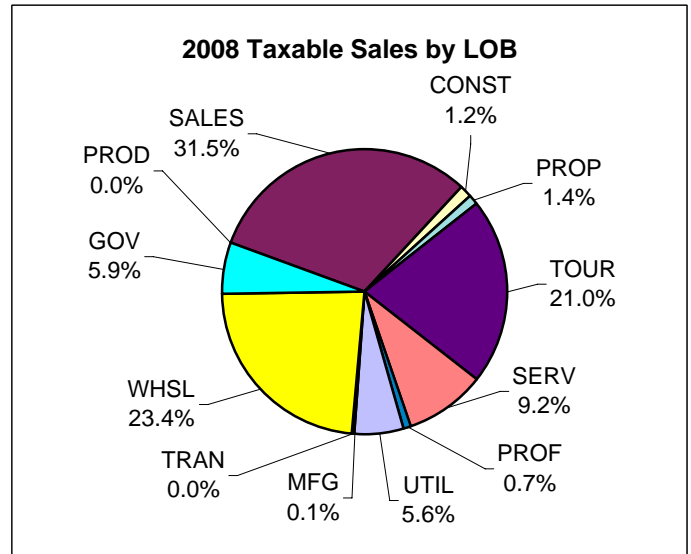

Chart 4.10

Seldovia TAXABLE Sales by Line of Business by Quarter - 2008 - in \$					
LOB	1st Quarter	2nd Quarter	3rd Quarter	4th Quarter	Total
Resource Production	0	0	1,000	0	1,000
Sales	243,606	479,332	576,652	275,210	1,574,800
Construction	4,582	15,615	23,549	15,181	58,927
Property	8,758	12,425	21,313	25,462	67,958
Tourism	103,934	635,922	308,331	4,944	1,053,131
Services	63,346	74,669	163,356	160,192	461,563
Professional	5,314	8,769	16,975	5,653	36,711
Utility	66,209	64,635	68,854	79,195	278,893
Manufacturing	500	1,328	3,667	520	6,015
Transportation & Warehousing	0	0	1,415	0	1,415
Wholesale	247,597	311,100	370,750	239,474	1,168,921
Government	106,386	59,596	78,158	51,402	295,542
TOTAL	850,232	1,663,391	1,634,020	857,233	5,004,876

Table 4.14

Seldovia Sales

Seldovia GROSS Sales by Line of Business by Quarter - 2007 - in \$					
LOB	1st Quarter	2nd Quarter	3rd Quarter	4th Quarter	Total
Resource Production	16	1	0	0	17
Sales	167,414	276,990	348,040	200,053	992,497
Construction	129,681	816,559	164,195	1,852,198	2,962,633
Property	24,309	13,260	11,291	58,943	107,803
Tourism	330,041	447,339	593,591	177,373	1,548,344
Services	90,387	204,058	225,604	151,394	671,443
Professional	51,036	139,361	100,724	144,461	435,582
Utility	125,641	101,555	117,755	113,235	458,186
Manufacturing	684	1,602	6,288	2,589	11,163
Transportation & Warehousing	237	10,325	848	7,741	19,151
Wholesale	415,748	463,239	478,446	563,842	1,921,275
Government	127,330	76,504	83,982	79,905	367,721
TOTAL	1,462,524	2,550,793	2,130,764	3,351,734	9,495,815

Table 4.15

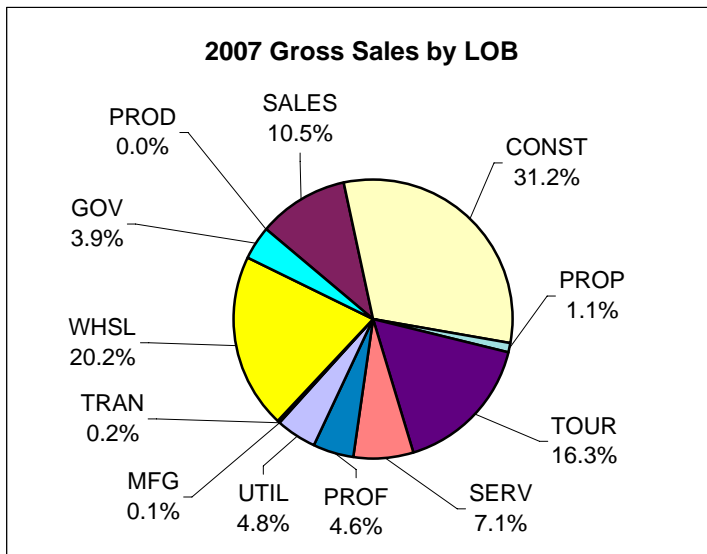

Chart 4.11

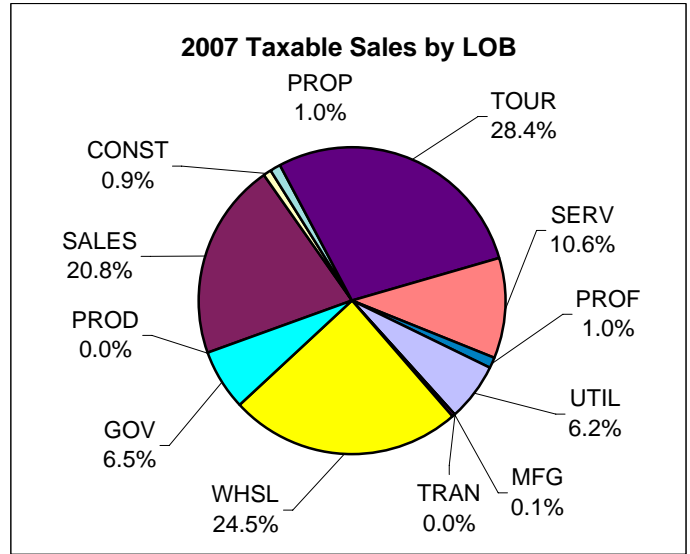

Chart 4.12

Seldovia TAXABLE Sales by Line of Business by Quarter - 2007 - in \$					
LOB	1st Quarter	2nd Quarter	3rd Quarter	4th Quarter	Total
Resource Production	16	0	0	0	16
Sales	147,999	252,567	316,004	179,849	896,419
Construction	7,431	7,079	8,383	17,941	40,834
Property	9,367	6,831	7,991	19,467	43,656
Tourism	120,309	402,587	543,693	158,641	1,225,230
Services	64,111	134,883	176,697	83,572	459,263
Professional	7,782	12,399	16,957	8,188	45,326
Utility	70,415	58,972	72,197	64,014	265,598
Manufacturing	619	500	1,673	1,057	3,849
Transportation & Warehousing	237	467	357	0	1,061
Wholesale	221,229	287,048	300,152	247,292	1,055,721
Government	106,286	57,503	64,772	52,194	280,755
TOTAL	755,801	1,220,836	1,508,876	832,215	4,317,728

Table 4.16

Seldovia Sales

Seldovia GROSS Sales by Line of Business by Quarter - 2006 - in \$					
LOB	1st Quarter	2nd Quarter	3rd Quarter	4th Quarter	Total
Resource Production	0	0	0	0	0
Sales	144,744	249,160	283,577	170,254	847,735
Construction	109,756	164,132	599,939	156,311	1,030,138
Property	419,507	573,282	260,066	63,355	1,316,210
Tourism	99,240	413,861	637,719	139,161	1,289,981
Services	77,270	104,192	127,272	97,459	406,193
Professional	7,933	14,624	18,226	115,693	156,476
Utility	119,187	98,564	95,245	121,920	434,916
Manufacturing	9,590	2,027	642	0	12,259
Transportation & Warehousing	36,307	26,338	933	6,215	69,793
Wholesale	375,650	418,821	414,788	389,339	1,598,598
Government	117,936	105,810	91,181	87,497	402,424
TOTAL	1,517,120	2,170,811	2,529,588	1,347,204	7,564,723

Table 4.17

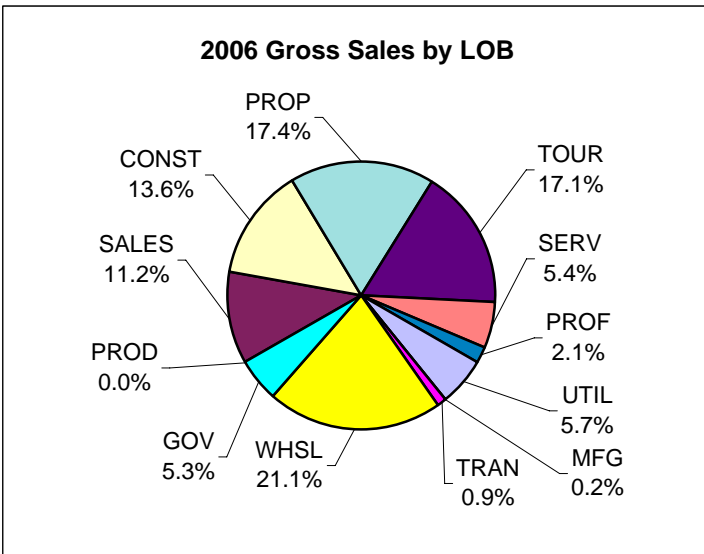

Chart 4.13

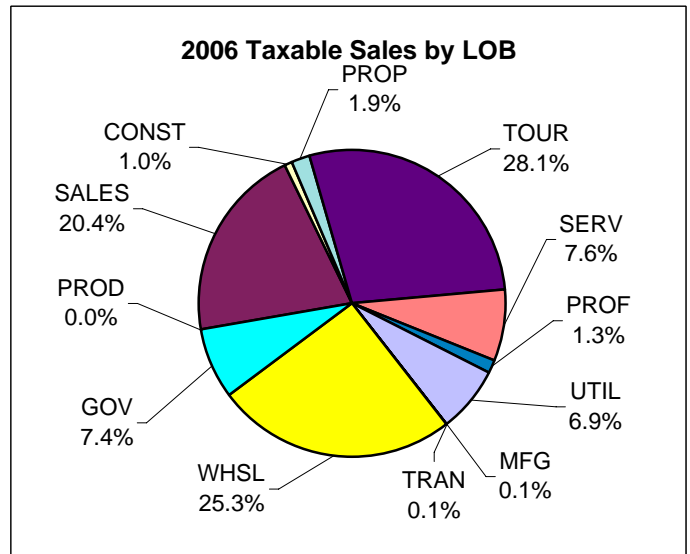

Chart 4.14

Seldovia TAXABLE Sales by Line of Business by Quarter - 2006 - in \$					
LOB	1st Quarter	2nd Quarter	3rd Quarter	4th Quarter	Total
Resource Production	0	0	0	0	0
Sales	124,028	216,749	258,004	150,789	749,570
Construction	6,985	7,858	12,958	7,079	34,880
Property	12,331	9,352	9,015	37,667	68,365
Tourism	87,219	287,228	545,954	110,318	1,030,719
Services	56,012	59,337	89,664	73,256	278,269
Professional	5,173	12,607	11,142	20,167	49,089
Utility	66,166	54,926	60,727	70,390	252,209
Manufacturing	2,813	27	390	0	3,230
Transportation & Warehousing	296	494	933	239	1,962
Wholesale	188,181	263,478	290,112	188,842	930,613
Government	87,490	62,443	69,165	53,075	272,173
TOTAL	636,694	974,499	1,348,064	711,822	3,671,079

Table 4.18

Seldovia Sales

Seldovia Annual Gross Sales by Quarter - in \$						
	1st Quarter	2nd Quarter	3rd Quarter	4th Quarter	Total	Annual Change
1995	962,895	1,802,578	1,869,108	1,203,280	5,837,861	
1996	864,931	1,406,053	2,438,766	1,020,242	5,729,992	-1.8%
1997	895,150	1,362,360	1,636,472	879,273	4,773,255	-16.7%
1998	935,674	1,331,163	1,584,201	872,701	4,723,739	-1.0%
1999	908,058	1,388,188	1,707,186	841,338	4,844,770	2.6%
2000	1,150,692	1,526,900	1,693,636	896,097	5,267,325	8.7%
2001	898,811	1,473,305	1,957,554	919,801	5,249,471	-0.3%
2002	1,011,712	1,155,055	1,694,174	956,936	4,817,877	-8.2%
2003	847,005	1,629,455	2,833,785	1,949,309	7,259,554	50.7%
2004	1,405,047	1,971,670	1,809,067	3,144,047	8,329,831	14.7%
2005	1,261,735	2,120,534	2,275,335	1,213,675	6,871,279	-17.5%
2006	1,517,120	2,170,811	2,529,588	1,347,204	7,564,723	10.1%
2007	1,462,524	2,550,793	2,130,764	3,351,734	9,495,815	25.5%
2008	1,516,251	2,591,665	2,347,161	2,075,704	8,530,781	-10.2%
Change	3.7%	1.6%	10.2%	-38.1%	-10.2%	

Table 4.19

Seldovia Annual Taxable Sales by Quarter - in \$						
	1st Quarter	2nd Quarter	3rd Quarter	4th Quarter	Total	Annual Change
1995	602,805	981,822	1,306,693	685,628	3,576,948	
1996	578,650	996,975	1,184,616	670,068	3,430,309	-4.1%
1997	549,337	1,001,066	1,199,774	585,846	3,336,023	-2.7%
1998	529,660	1,000,949	1,251,027	616,657	3,398,293	1.9%
1999	569,438	915,962	1,144,627	599,222	3,229,249	-5.0%
2000	569,093	1,018,255	1,241,108	589,667	3,418,123	5.8%
2001	583,555	956,033	1,207,525	612,166	3,359,279	-1.7%
2002	573,624	898,830	1,191,989	607,946	3,272,389	-2.6%
2003	598,970	962,966	1,140,319	674,689	3,376,944	3.2%
2004	566,726	939,589	1,182,138	697,859	3,386,312	0.3%
2005	573,017	932,141	1,215,676	660,146	3,380,980	-0.2%
2006	636,694	974,499	1,348,064	711,822	3,671,079	8.6%
2007	755,801	1,220,836	1,508,876	832,215	4,317,728	17.6%
2008	850,232	1,663,391	1,634,020	857,233	5,004,876	15.9%
Change	12.5%	36.3%	8.3%	3.0%	15.9%	

Table 4.20

Seldovia Annual Non-Taxable Sales by Quarter - in \$						
	1st Quarter	2nd Quarter	3rd Quarter	4th Quarter	Total	Annual Change
1995	360,090	820,756	562,415	517,652	2,260,913	
1996	286,281	409,078	1,254,150	350,174	2,299,683	1.7%
1997	345,813	361,294	436,698	293,427	1,437,232	-37.5%
1998	406,014	330,214	333,174	256,044	1,325,446	-7.8%
1999	338,620	472,226	562,559	242,116	1,615,521	21.9%
2000	581,599	508,645	452,528	306,430	1,849,202	14.5%
2001	315,256	517,272	750,029	307,635	1,890,192	2.2%
2002	438,088	256,225	502,185	348,990	1,545,488	-18.2%
2003	248,035	666,489	1,693,466	1,274,620	3,882,610	151.2%
2004	838,321	1,032,081	626,929	2,446,188	4,943,519	27.3%
2005	688,718	1,188,393	1,059,659	553,529	3,490,299	-29.4%
2006	880,426	1,196,312	1,181,524	635,382	3,893,644	11.6%
2007	706,723	1,329,957	621,888	2,519,519	5,178,087	33.0%
2008	666,019	928,274	713,141	1,218,471	3,525,905	-31.9%
Change	-5.8%	-30.2%	14.7%	-51.6%	-31.9%	

Table 4.21

Seldovia Construction Permits

Seldovia 4th Quarter Permit VALUES by Type - 2002-2008 - in \$								
	2002	2003	2004	2005	2006	2007	2008	Annual Change
Residential New	0	26,000	0	0	0	0	0	0.0%
Residential Alter/Add	20,000	3,000	0	0	0	1,000	10,000	900.0%
Commercial New	0	7,500	0	0	0	0	0	0.0%
Commercial Alter/Add	0	0	0	500	18,000	0	0	0.0%
Total	20,000	36,500	0	500	18,000	1,000	10,000	900.0%
Annual Change		82.5%	-100.0%	NA	3500.0%	-94.4%	900.0%	

Table 4.22

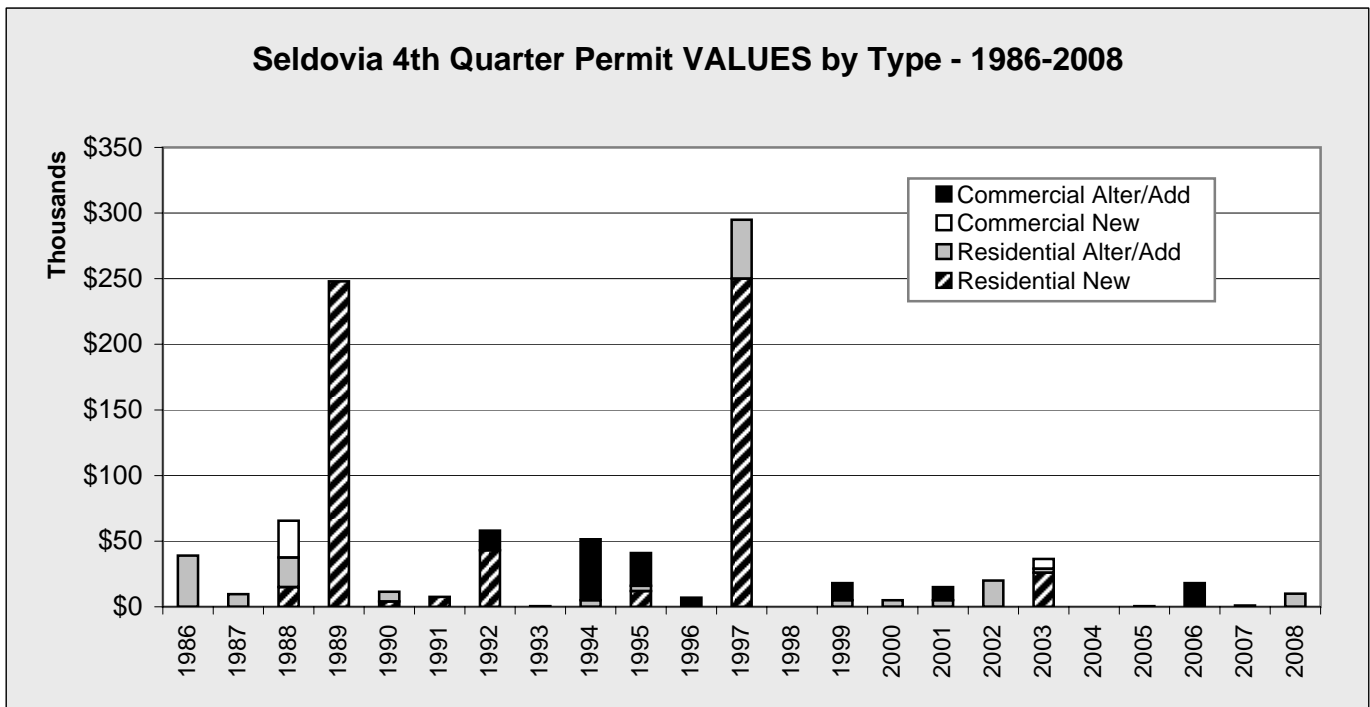

Chart 4.15

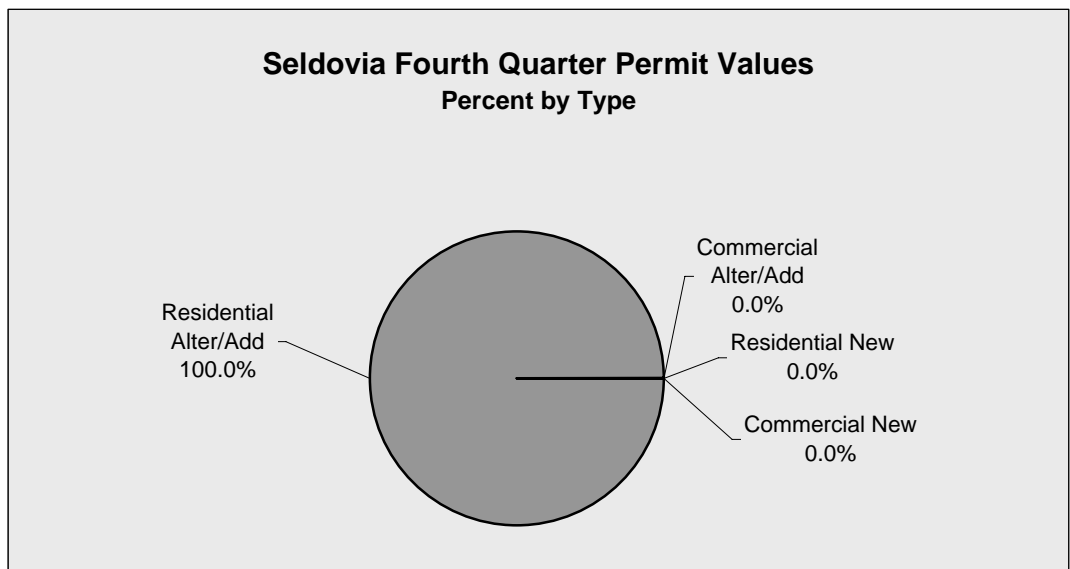

Chart 4.16

Seldovia Construction Permits

Seldovia 4th Quarter Permit VOLUME by Type - 2002-2008								
	2002	2003	2004	2005	2006	2007	2008	Annual Change
Residential New	0	2	0	0	0	0	0	0.0%
Residential Alter/Add	1	1	0	0	0	1	1	0.0%
Commercial New	0	1	0	0	0	0	0	0.0%
Commercial Alter/Add	0	0	0	1	1	0	0	0.0%
Total	1	4	0	1	1	1	1	0.0%
Annual Change		300.0%	-100.0%	NA	0.0%	0.0%	0.0%	

Table 4.23

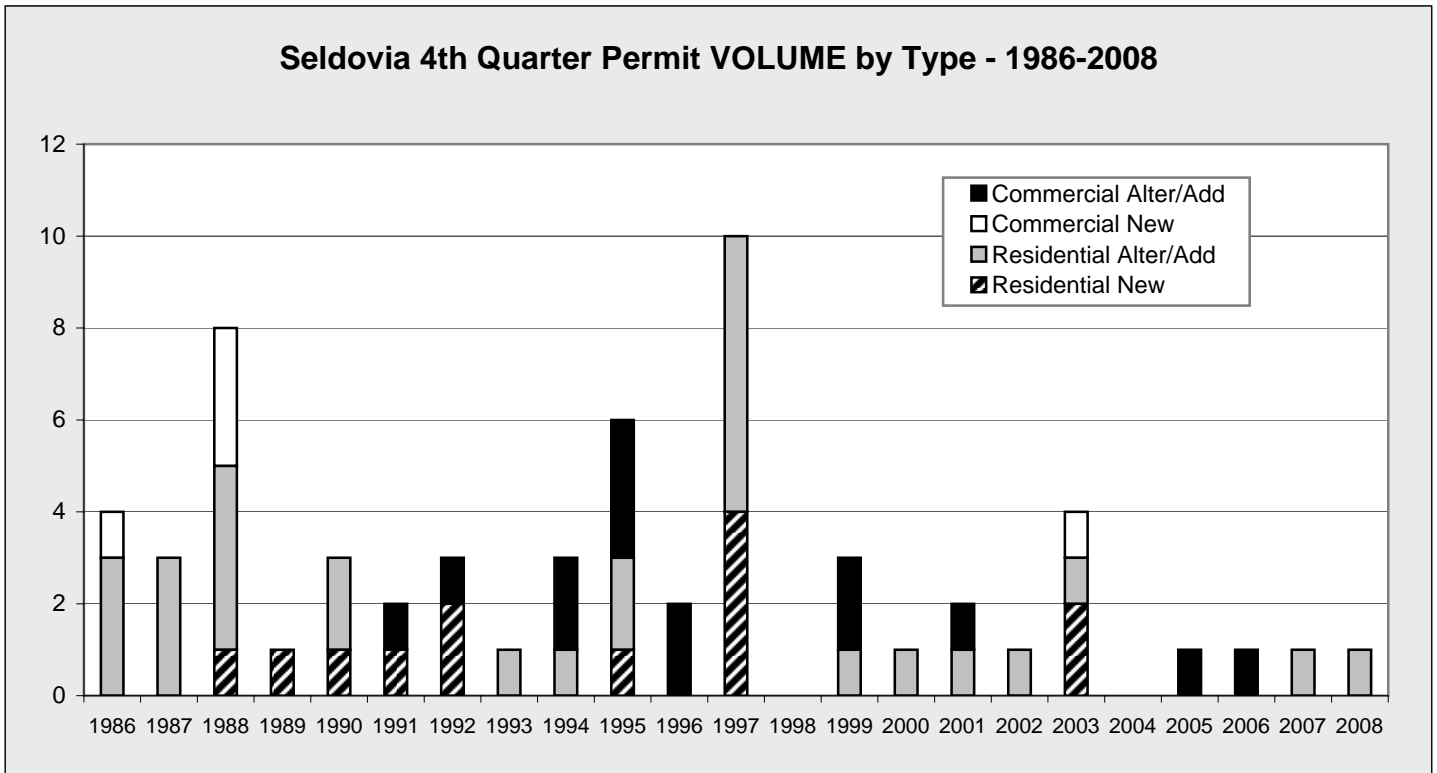

Chart 4.17

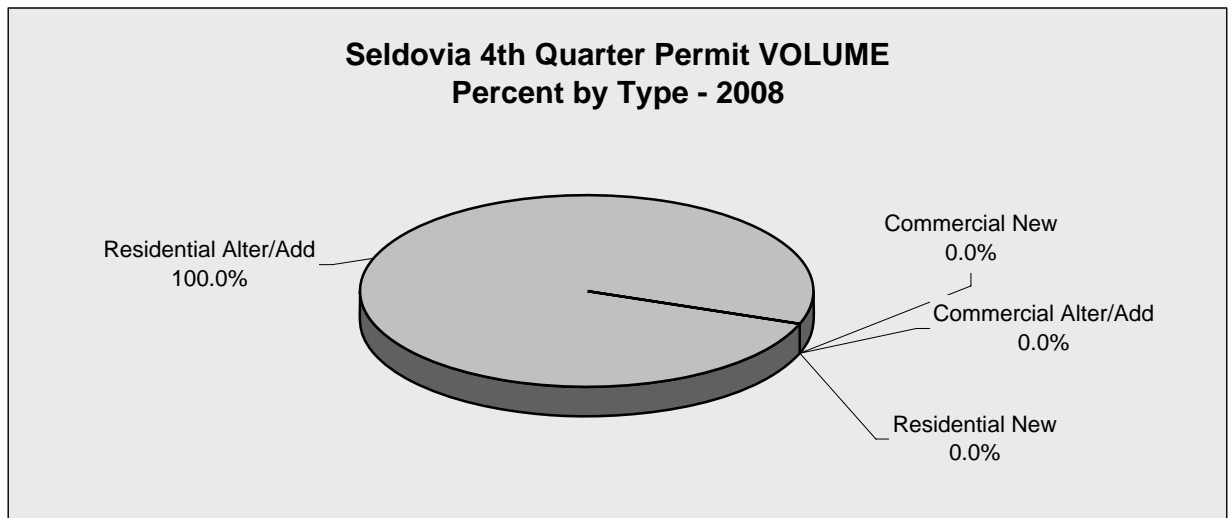

Chart 4.18

Seldovia Construction Permits

Seldovia Annual Permit VALUES by Type - 2002-2008 - in \$								
	2002	2003	2004	2005	2006	2007	2008	Annual Change
Residential New	308,000	176,000	170,000	300,000	85,000	252,000	350,000	38.9%
Residential Alter/Add	48,500	34,000	6,200	49,000	32,000	61,800	24,500	-60.4%
Commercial New	0	1,692,500	0	8,000	0	2,000	3,000	50.0%
Commercial Alter/Add	0	0	0	155,000	18,000	28,000	5,000	-82.1%
Total	356,500	1,902,500	176,200	512,000	135,000	343,800	382,500	11.3%
Annual Change		433.7%	-90.7%	190.6%	-73.6%	154.7%	11.3%	

Table 4.24

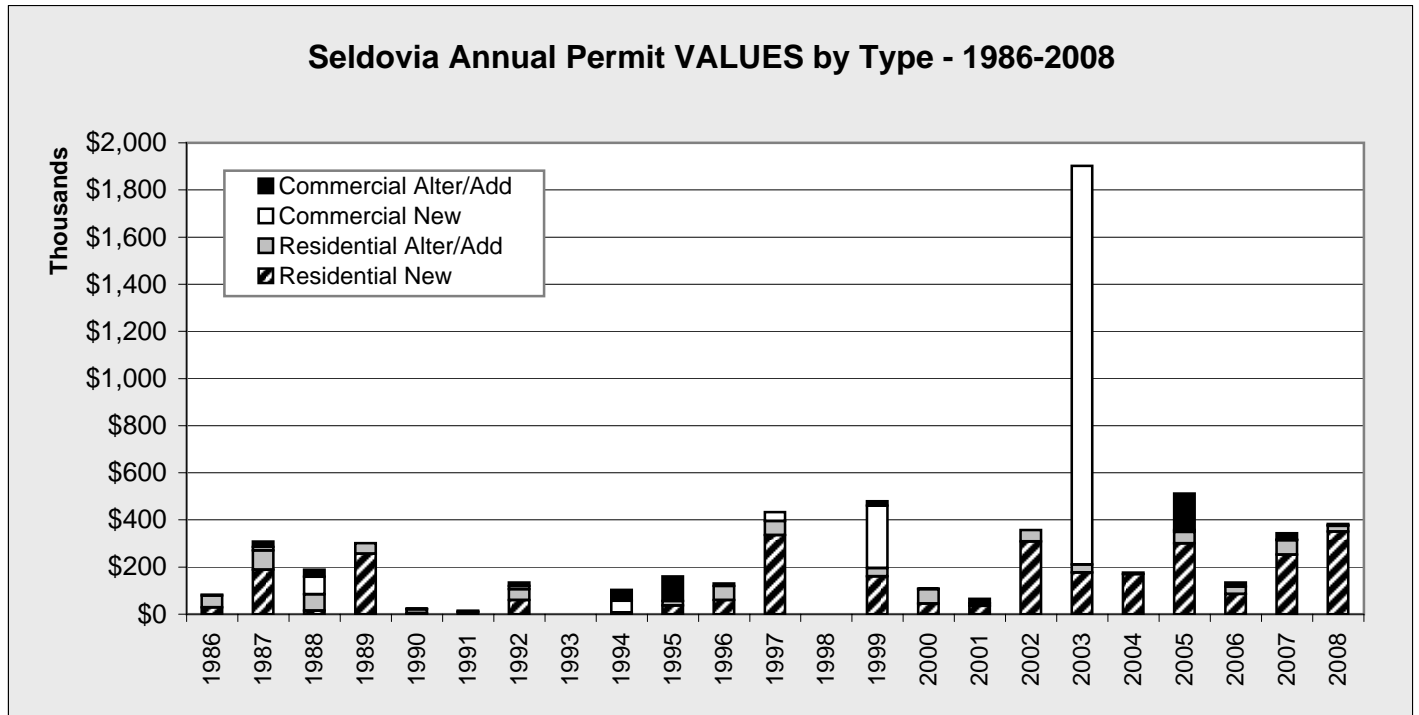

Chart 4.19

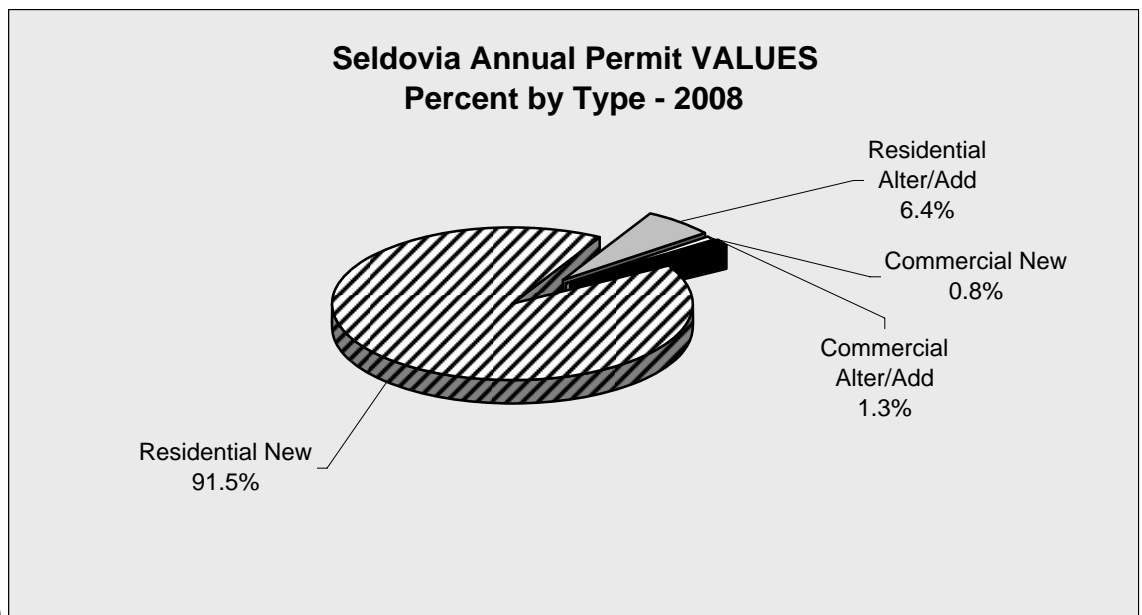

Chart 4.20

Seldovia Construction Permits

Seldovia Annual Permit VOLUME by Type - 2002-2008								
	2002	2003	2004	2005	2006	2007	2008	Annual Change
Residential New	2	3	2	2	3	4	2	-50.0%
Residential Alter/Add	6	4	2	3	3	10	3	-70.0%
Commercial New	0	4	0	1	0	1	0	-100.0%
Commercial Alter/Add	0	1	0	4	2	3	2	-33.3%
Total	8	12	4	10	8	18	7	-61.1%
Annual Change		50.0%	-66.7%	150.0%	-20.0%	125.0%	-61.1%	

Table 4.25

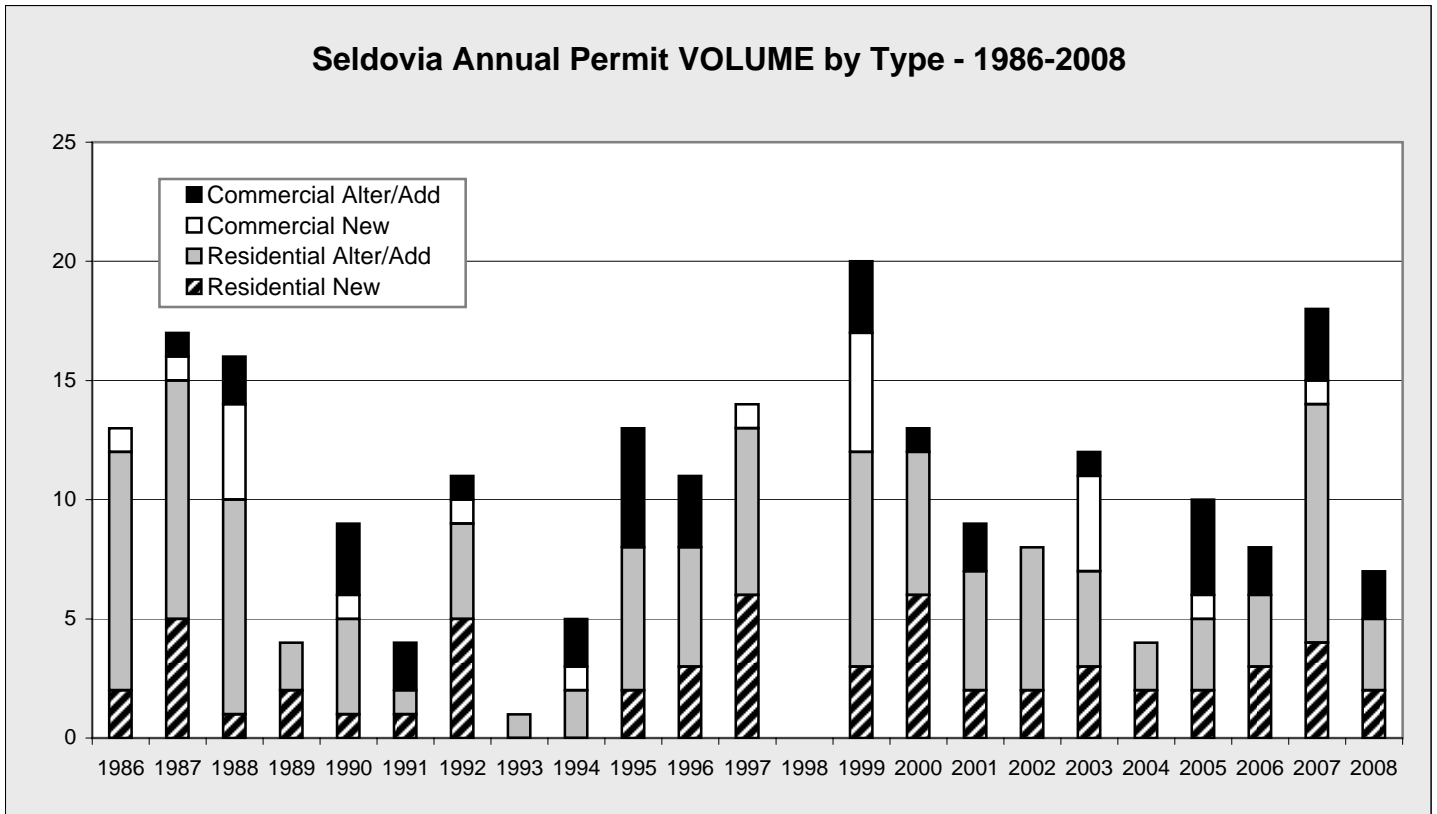

Chart 4.21

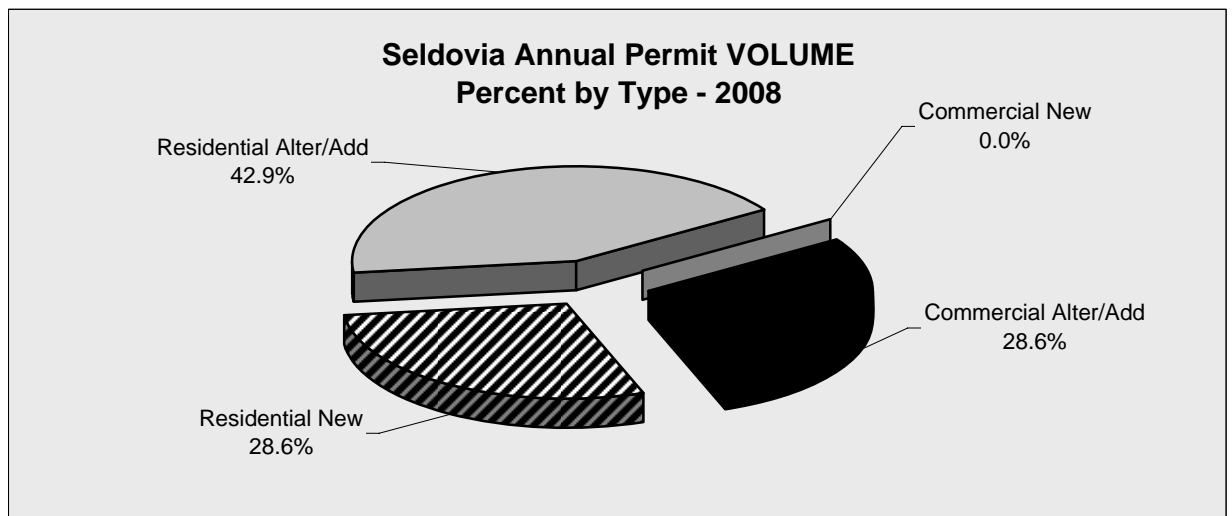

Chart 4.22

Seldovia Construction Permits

Seldovia Annual Permit VALUE by Type by Quarter - 2001-2008 - in \$					
	1st Quarter	2nd Quarter	3rd Quarter	4th Quarter	Total
2001					
Residential - New	0	25,000	10,000	0	35,000
Residential - Add/Alter	0	0	5,525	5,000	10,525
Commercial - New	0	0	0	0	0
Commercial - Add/Alter	10,000	0	0	10,000	20,000
TOTAL	10,000	25,000	15,525	15,000	65,525
2002					
Residential - New	0	0	308,000	0	308,000
Residential - Add/Alter	10,000	8,000	10,500	20,000	48,500
Commercial - New	0	0	0	0	0
Commercial - Add/Alter	0	0	0	0	0
TOTAL	10,000	8,000	318,500	20,000	356,500
2003					
Residential - New	0	0	150,000	26,000	176,000
Residential - Add/Alter	31,000	0	0	3,000	34,000
Commercial - New	0	0	1,685,000	7,500	1,692,500
Commercial - Add/Alter	0	0	0	0	0
TOTAL	31,000	0	1,835,000	36,500	1,902,500
2004					
Residential - New	20,000	150,000	0	0	170,000
Residential - Add/Alter	0	6,200	0	0	6,200
Commercial - New	0	0	0	0	0
Commercial - Add/Alter	0	0	0	0	0
TOTAL	20,000	156,200	0	0	176,200
2005					
Residential - New	0	300,000	0	0	300,000
Residential - Add/Alter	15,000	4,000	30,000	0	49,000
Commercial - New	0	8,000	0	0	8,000
Commercial - Add/Alter	0	154,000	500	500	155,000
TOTAL	15,000	466,000	30,500	500	512,000
2006					
Residential - New	30,000	55,000	0	0	85,000
Residential - Add/Alter	0	32,000	0	0	32,000
Commercial - New	0	0	0	0	0
Commercial - Add/Alter	0	0	0	18,000	18,000
TOTAL	30,000	87,000	0	18,000	135,000
2007					
Residential - New	0	227,000	25,000	0	252,000
Residential - Add/Alter	15,000	30,000	15,800	1,000	61,800
Commercial - New	0	2,000	0	0	2,000
Commercial - Add/Alter	0	8,000	20,000	0	28,000
TOTAL	15,000	267,000	60,800	1,000	343,800
2008					
Residential - New	0	0	350,000	0	350,000
Residential - Add/Alter	12,000	2,500	0	10,000	24,500
Commercial - New	0	0	3,000	0	3,000
Commercial - Add/Alter	0	5,000	0	0	5,000
TOTAL	12,000	7,500	353,000	10,000	382,500

Table 4.26

Seldovia Construction Permits

Seldovia Annual Permit VOLUME by Type by Quarter - 2001-2008					
	1st Quarter	2nd Quarter	3rd Quarter	4th Quarter	Total
2001					
Residential - New	0	1	1	0	2
Residential - Add/Alter	0	0	4	1	5
Commercial - New	0	0	0	0	0
Commercial - Add/Alter	1	0	0	1	2
TOTAL	1	1	5	2	9
2002					
Residential - New	0	0	2	0	2
Residential - Add/Alter	1	2	2	1	6
Commercial - New	0	0	0	0	0
Commercial - Add/Alter	0	0	0	0	0
TOTAL	1	2	4	1	8
2003					
Residential - New	0	0	1	2	3
Residential - Add/Alter	3	0	0	1	4
Commercial - New	0	0	3	1	4
Commercial - Add/Alter	0	0	1	0	1
TOTAL	3	0	5	4	12
2004					
Residential - New	1	1	0	0	2
Residential - Add/Alter	0	2	0	0	2
Commercial - New	0	0	0	0	0
Commercial - Add/Alter	0	0	0	0	0
TOTAL	1	3	0	0	4
2005					
Residential - New	0	2	0	0	2
Residential - Add/Alter	1	1	1	0	3
Commercial - New	0	1	0	0	1
Commercial - Add/Alter	0	2	1	1	4
TOTAL	1	6	2	1	10
2006					
Residential - New	1	2	0	0	3
Residential - Add/Alter	0	3	0	0	3
Commercial - New	0	0	0	0	0
Commercial - Add/Alter	0	1	0	1	2
TOTAL	1	6	0	1	8
2007					
Residential - New	0	3	1	0	4
Residential - Add/Alter	1	4	4	1	10
Commercial - New	0	1	0	0	1
Commercial - Add/Alter	0	1	2	0	3
TOTAL	1	9	7	1	18
2008					
Residential - New	0	0	2	0	2
Residential - Add/Alter	1	1	0	1	3
Commercial - New	0	0	0	0	0
Commercial - Add/Alter	0	1	1	0	2
TOTAL	1	2	3	1	7

Table 4.27

Seward Sales

Seward Fourth Quarter GROSS Sales by Line of Business - 2003-2008 - in \$								
LOB	2003	2004	2005	2006	2007	2008	Annual Percent Change	Annual Amount Change
PROD	23,269	35,416	0	48,714	22,331	0	-100.0%	-22,331
SALES	6,126,606	6,319,248	6,967,267	7,570,055	8,037,200	8,898,311	10.7%	861,111
CONST	5,568,449	16,439,744	8,040,970	20,646,981	7,100,187	12,659,525	78.3%	5,559,338
PROP	2,586,245	1,835,051	2,867,171	2,080,121	1,911,523	2,034,871	6.5%	123,348
TOUR	1,718,285	2,243,854	2,263,482	2,199,001	2,257,049	1,673,410	-25.9%	-583,639
SERV	1,640,791	1,782,019	1,823,172	1,988,097	2,132,837	1,841,720	-13.6%	-291,117
PROF	603,189	2,059,288	1,913,831	1,828,168	1,738,095	1,864,509	7.3%	126,414
UTIL	675,956	702,113	821,296	1,055,935	1,053,832	1,261,345	19.7%	207,513
MANU	3,232,108	1,386,538	2,641,730	2,152,379	2,885,198	1,740,649	-39.7%	-1,144,549
TRAN	481,327	599,721	624,022	531,208	807,754	523,843	-35.1%	-283,911
WHLS	3,292,713	3,472,231	4,601,966	8,103,644	4,769,707	4,195,736	-12.0%	-573,971
GOV	1,385,476	1,487,599	1,648,774	1,766,151	1,932,654	2,114,626	9.4%	181,972
TOTAL	27,334,414	38,362,822	34,213,681	49,970,454	34,648,367	38,808,545	12.0%	4,160,178

Table 5.1 For complete listing of Lines of Business, see page 13

Fourth Quarter GROSS Sales	
2003	27,334,414
2004	38,362,822
2005	34,213,681
2006	49,970,454
2007	34,648,367
2008	38,808,545

Table 5.2

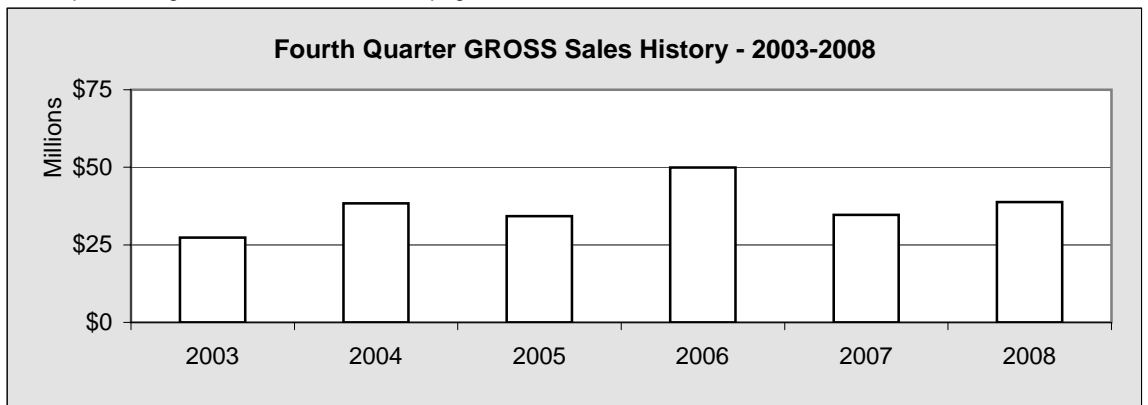

Chart 5.1

Five Year Change Fourth Quarter GROSS Sales		
	2003	2008
PROD	23,269	0
SALES	6,126,606	8,898,311
CONST	5,568,449	12,659,525
PROP	2,586,245	2,034,871
TOUR	1,718,285	1,673,410
SERV	1,640,791	1,841,720
PROF	603,189	1,864,509
UTIL	675,956	1,261,345
MANU	3,232,108	1,740,649
TRAN	481,327	523,843
WHLS	3,292,713	4,195,736
GOV	1,385,476	2,114,626
TOTAL	27,334,414	38,808,545

Table 5.3

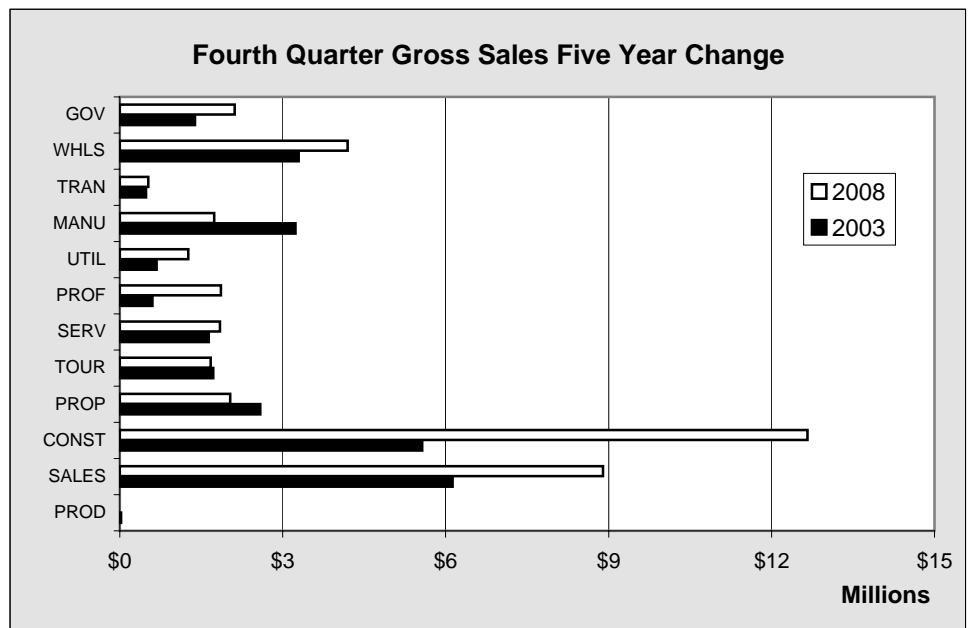

Chart 5.2

Seward Sales

Seward Fourth Quarter TAXABLE Sales by Line of Business - 2003-2008 - in \$								
LOB	2003	2004	2005	2006	2007	2008	Annual Percent Change	Annual Amount Change
PROD	118	0	0	0	0	0	0.0%	0
SALES	4,966,976	4,951,964	5,676,326	5,989,723	6,485,560	7,328,257	13.0%	842,697
CONST	180,614	173,069	161,751	184,521	160,333	168,767	5.3%	8,434
PROP	413,723	418,447	409,128	474,893	484,735	506,617	4.5%	21,882
TOUR	1,518,043	1,500,120	1,458,079	1,363,185	1,341,551	783,376	-41.6%	-558,175
SERV	958,881	934,022	1,028,555	1,120,842	1,192,602	1,097,164	-8.0%	-95,438
PROF	110,218	121,457	111,690	122,894	148,292	133,850	-9.7%	-14,442
UTIL	801	416	0	2,745	1,251	1,100	-12.1%	-151
MANU	121,178	118,603	74,413	86,884	128,443	141,470	10.1%	13,027
TRAN	21,850	26,309	123,920	34,452	33,175	16,450	-50.4%	-16,725
WHLS	611,424	720,266	773,219	810,870	846,894	862,685	1.9%	15,791
GOV	1,385,476	1,423,599	1,584,694	1,693,871	1,860,654	2,040,626	9.7%	179,972
TOTAL	10,289,302	10,388,272	11,401,775	11,884,880	12,683,490	13,080,362	3.1%	396,872

Table 5.4

For complete listing of Lines of Business, see page 13

4th Quarter TAXABLE Sales History	
2003	10,289,302
2004	10,388,272
2005	11,401,775
2006	11,884,880
2007	12,683,490
2008	13,080,362

Table 5.5

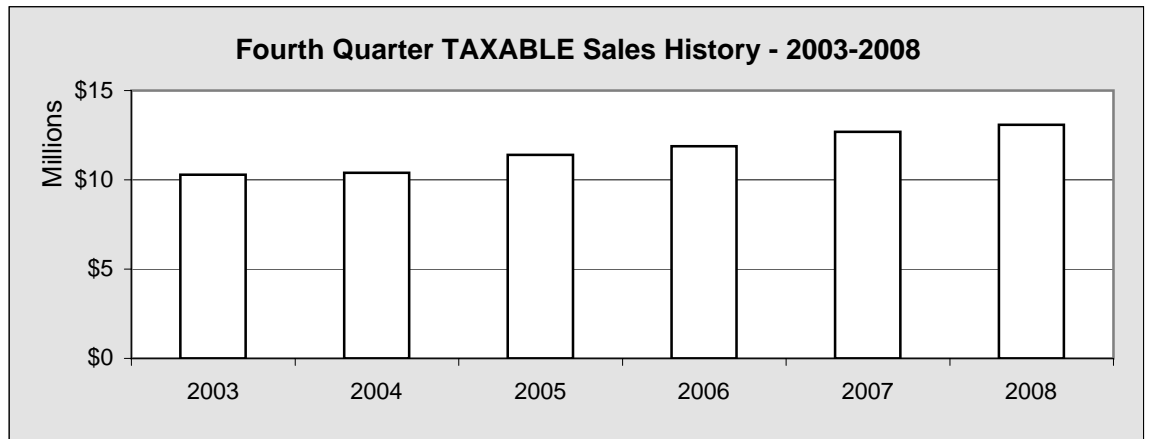

Chart 5.3

Five Year Change Fourth Quarter TAXABLE Sales		
	2003	2008
PROD	118	0
SALES	4,966,976	7,328,257
CONST	180,614	168,767
PROP	413,723	506,617
TOUR	1,518,043	783,376
SERV	958,881	1,097,164
PROF	110,218	133,850
UTIL	801	1,100
MANU	121,178	141,470
TRAN	21,850	16,450
WHLS	611,424	862,685
GOV	1,385,476	2,040,626
TOTAL	10,289,302	13,080,362

Table 5.6

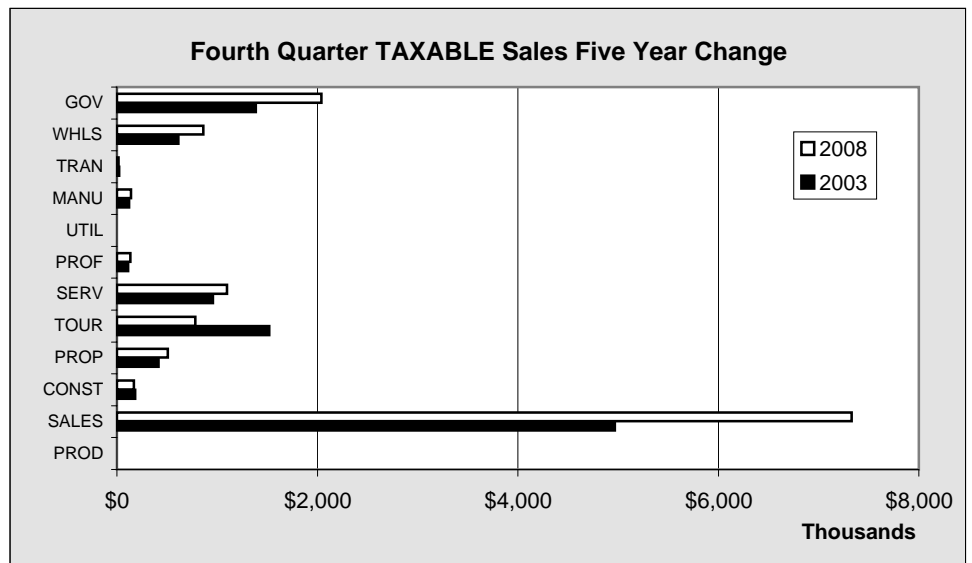

Chart 5.4

Seward Sales

Seward Annual GROSS Sales by Line of Business - 2003-2008 - in \$

LOB	2003	2004	2005	2006	2007	2008	Annual Percent Change	Annual Amount Change
PROD	208,545	228,403	227,768	49,738	327,692	105,425	-67.8%	-222,267
SALES	34,477,861	36,812,924	42,226,370	44,401,192	49,619,690	55,699,276	12.3%	6,079,586
CONST	28,119,593	30,132,289	39,812,044	39,567,262	20,691,970	30,696,120	48.3%	10,004,150
PROP	9,327,416	8,402,843	8,536,636	8,267,710	7,768,625	7,889,016	1.5%	120,391
TOUR	32,620,200	36,285,102	38,643,753	39,474,443	43,173,582	39,168,283	-9.3%	-4,005,299
SERV	9,172,023	9,192,098	8,372,277	8,780,572	11,559,163	10,024,393	-13.3%	-1,534,770
PROF	3,099,221	3,533,910	3,890,494	4,824,944	4,041,647	6,058,799	49.9%	2,017,152
UTIL	2,572,129	2,072,046	3,313,549	4,001,907	4,411,620	4,789,813	8.6%	378,193
MANU	13,462,919	10,505,152	13,089,654	10,825,783	17,919,182	17,453,128	-2.6%	-466,054
TRAN	5,143,592	4,648,661	4,645,626	4,346,626	4,975,690	5,720,557	15.0%	744,867
WHLS	13,481,435	18,672,628	20,448,645	27,657,738	24,220,285	30,168,944	24.6%	5,948,659
GOV	5,277,002	5,530,886	5,898,177	6,159,339	6,539,108	6,801,021	4.0%	261,913
TOTAL	156,961,936	166,016,942	189,104,993	198,357,254	195,248,254	214,574,775	9.9%	19,326,521

Table 5.7

For complete listing of Lines of Business, see page 13

Annual GROSS Sales History	
2003	156,961,936
2004	166,016,942
2005	189,104,993
2006	198,357,254
2007	195,248,254
2008	214,574,775

Table 5.8

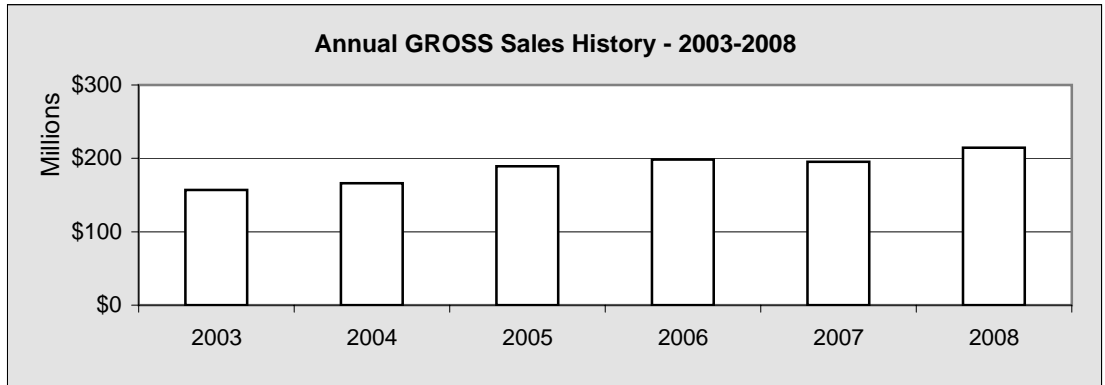

Chart 5.5

Five Year Change Annual GROSS Sales		
	2003	2008
PROD	208,545	105,425
SALES	34,477,861	55,699,276
CONST	28,119,593	30,696,120
PROP	9,327,416	7,889,016
TOUR	32,620,200	39,168,283
SERV	9,172,023	10,024,393
PROF	3,099,221	6,058,799
UTIL	2,572,129	4,789,813
MANU	13,462,919	17,453,128
TRAN	5,143,592	5,720,557
WHLS	13,481,435	30,168,944
GOV	5,277,002	6,801,021
TOTAL	156,961,936	214,574,775

Table 5.9

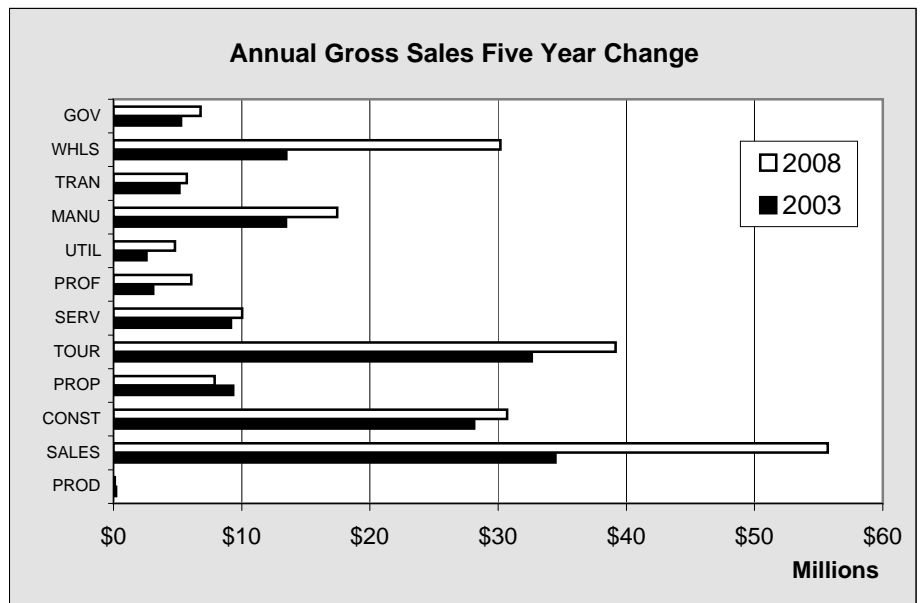

Chart 5.6

Seward Sales

Seward Annual TAXABLE Sales by Line of Business - 2003-2008 - in \$								
LOB	2003	2004	2005	2006	2007	2008	Annual Percent Change	Annual Amount Change
PROD	4,245	0	0	1,024	500	113	-77.4%	-387
SALES	28,162,331	29,812,800	34,557,054	36,549,236	40,808,140	47,295,682	15.9%	6,487,542
CONST	680,387	693,308	685,553	697,846	621,401	615,140	-1.0%	-6,261
PROP	2,442,068	2,054,719	2,109,278	2,094,443	2,426,692	2,648,265	9.1%	221,573
TOUR	29,288,845	30,595,843	32,615,913	33,711,217	38,893,264	34,735,735	-10.7%	-4,157,529
SERV	4,228,655	4,555,875	4,489,632	4,770,338	5,625,187	5,363,162	-4.7%	-262,025
PROF	714,967	643,915	643,442	672,854	710,350	644,427	-9.3%	-65,923
UTIL	5,583	1,261	3,979	8,183	8,595	5,595	-34.9%	-3,000
MANU	965,413	1,043,346	954,243	979,243	1,046,510	1,007,740	-3.7%	-38,770
TRAN	449,829	218,804	398,174	265,138	182,812	192,933	5.5%	10,121
WHLS	4,134,748	4,680,451	5,457,638	5,253,373	5,465,167	5,767,956	5.5%	302,789
GOV	5,271,662	5,466,886	5,834,097	6,087,059	6,467,108	6,727,021	4.0%	259,913
TOTAL	76,348,733	79,767,208	87,749,003	91,089,954	102,255,726	105,003,769	2.7%	2,748,043

Table 5.10 For complete listing of Lines of Business, see page 13

Annual TAXABLE Sales History	
2003	76,348,733
2004	79,767,208
2005	87,749,003
2006	91,089,954
2007	102,255,726
2008	105,003,769

Table 5.11

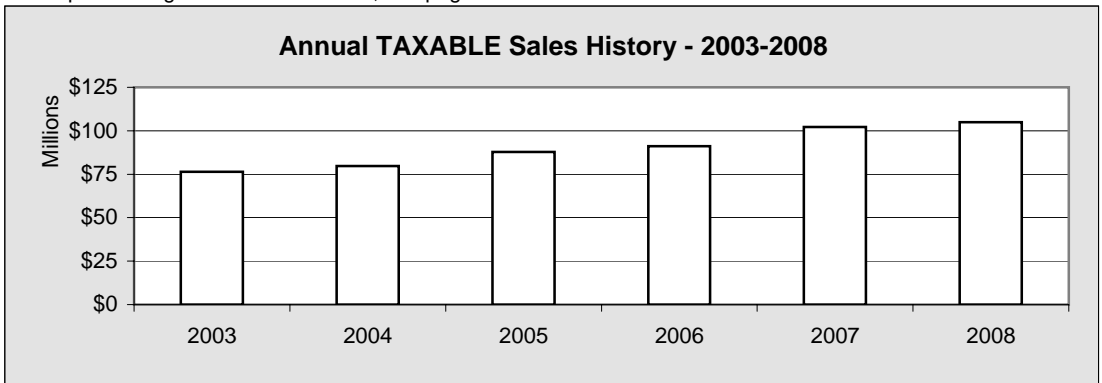

Chart 5.7

Five Year Change Annual TAXABLE Sales		
	2003	2008
PROD	4,245	113
SALES	28,162,331	47,295,682
CONST	680,387	615,140
PROP	2,442,068	2,648,265
TOUR	29,288,845	34,735,735
SERV	4,228,655	5,363,162
PROF	714,967	644,427
UTIL	5,583	5,595
MANU	965,413	1,007,740
TRAN	449,829	192,933
WHLS	4,134,748	5,767,956
GOV	5,271,662	6,727,021
TOTAL	76,348,733	105,003,769

Table 5.12

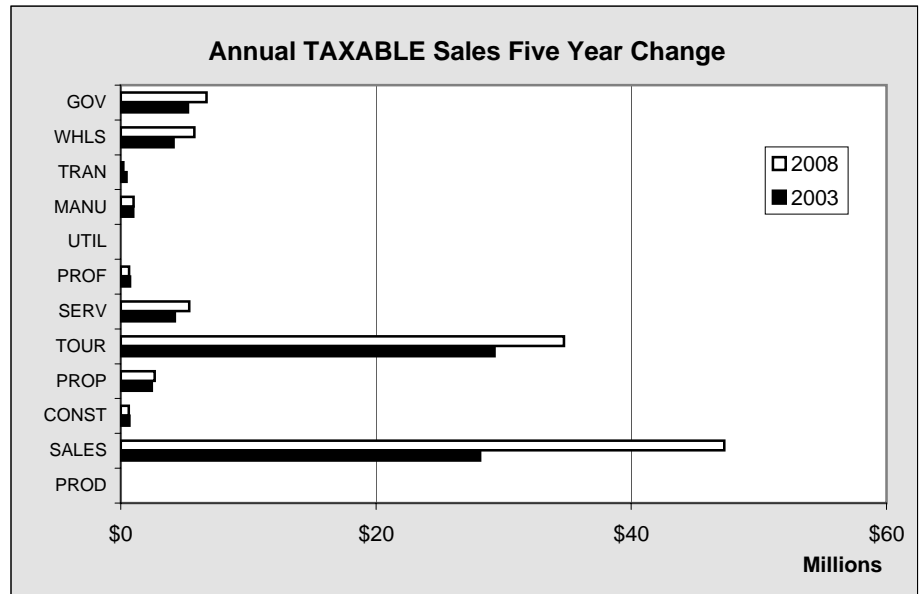

Chart 5.8

Seward Sales

Seward GROSS Sales by Line of Business by Quarter - 2008 - in \$					
LOB	1st Quarter	2nd Quarter	3rd Quarter	4th Quarter	Total
Resource Production	37,527	67,898	0	0	105,425
Sales	8,364,730	15,516,923	22,919,312	8,898,311	55,699,276
Construction	3,193,803	6,905,263	7,937,529	12,659,525	30,696,120
Property	1,380,136	1,986,945	2,487,064	2,034,871	7,889,016
Tourism	1,033,658	12,040,452	24,420,763	1,673,410	39,168,283
Services	1,960,925	2,948,372	3,273,376	1,841,720	10,024,393
Professional	1,156,667	1,217,305	1,820,318	1,864,509	6,058,799
Utility	1,081,208	1,085,357	1,361,903	1,261,345	4,789,813
Manufacturing	2,309,720	5,348,136	8,054,623	1,740,649	17,453,128
Transportation & Warehousing	409,250	1,528,172	3,259,292	523,843	5,720,557
Wholesale	4,356,490	9,597,038	12,019,680	4,195,736	30,168,944
Government	1,221,955	1,572,535	1,891,905	2,114,626	6,801,021
TOTAL	26,506,069	59,814,396	89,445,765	38,808,545	214,574,775

Table 5.13

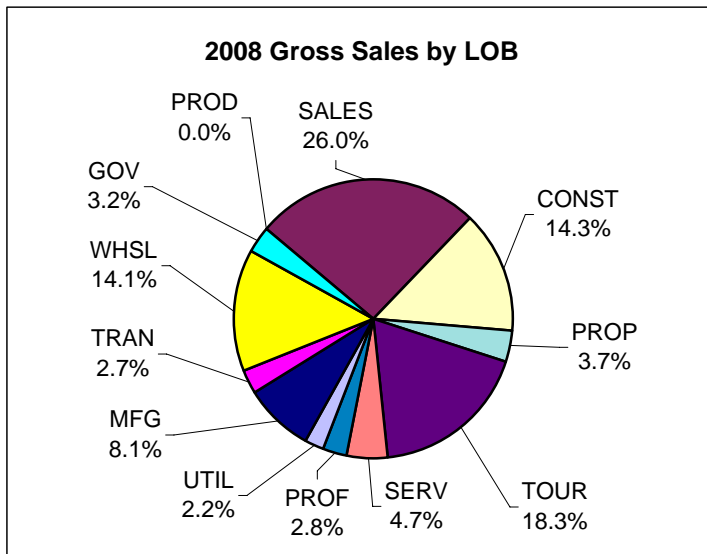

Chart 5.9

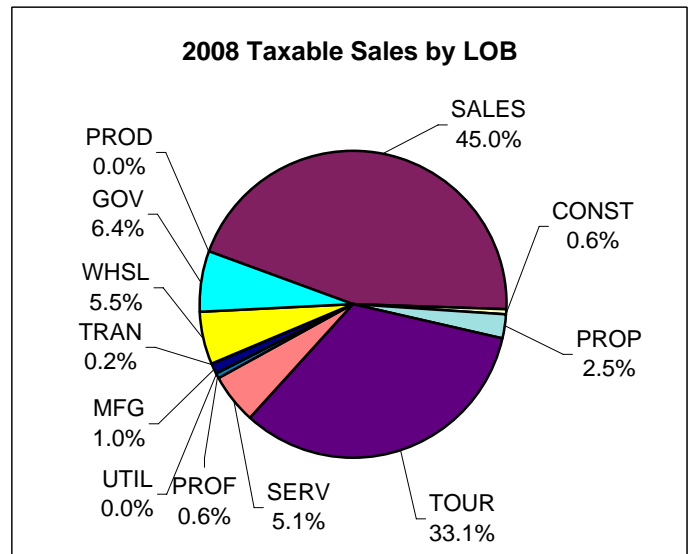

Chart 5.10

Seward TAXABLE Sales by Line of Business by Quarter - 2008 - in \$					
LOB	1st Quarter	2nd Quarter	3rd Quarter	4th Quarter	Total
Resource Production	113	0	0	0	113
Sales	6,526,015	13,360,057	20,081,353	7,328,257	47,295,682
Construction	135,194	165,643	145,536	168,767	615,140
Property	408,100	700,751	1,032,797	506,617	2,648,265
Tourism	734,363	10,843,147	22,374,849	783,376	34,735,735
Services	1,096,653	1,468,793	1,700,552	1,097,164	5,363,162
Professional	96,211	169,106	245,260	133,850	644,427
Utility	1,237	1,089	2,169	1,100	5,595
Manufacturing	75,080	353,311	437,879	141,470	1,007,740
Transportation & Warehousing	16,873	69,036	90,574	16,450	192,933
Wholesale	1,027,859	1,490,931	2,386,481	862,685	5,767,956
Government	1,221,955	1,572,535	1,891,905	2,040,626	6,727,021
TOTAL	11,339,653	30,194,399	50,389,355	13,080,362	105,003,769

Table 5.14

Seward Sales

Seward GROSS Sales by Line of Business by Quarter - 2007 - in \$					
LOB	1st Quarter	2nd Quarter	3rd Quarter	4th Quarter	Total
Resource Production	45,858	206,400	53,103	22,331	327,692
Sales	7,377,317	13,874,768	20,330,405	8,037,200	49,619,690
Construction	3,870,279	6,477,205	3,244,299	7,100,187	20,691,970
Property	1,291,921	1,815,253	2,749,928	1,911,523	7,768,625
Tourism	1,599,015	13,340,879	25,976,639	2,257,049	43,173,582
Services	2,086,448	3,621,474	3,718,404	2,132,837	11,559,163
Professional	574,529	752,534	976,489	1,738,095	4,041,647
Utility	1,163,003	1,124,674	1,070,111	1,053,832	4,411,620
Manufacturing	1,677,929	6,155,744	7,200,311	2,885,198	17,919,182
Transportation & Warehousing	239,160	1,387,802	2,540,974	807,754	4,975,690
Wholesale	4,279,210	6,298,639	8,872,729	4,769,707	24,220,285
Government	1,403,466	1,553,483	1,649,505	1,932,654	6,539,108
TOTAL	25,608,135	56,608,855	78,382,897	34,648,367	195,248,254

Table 5.15

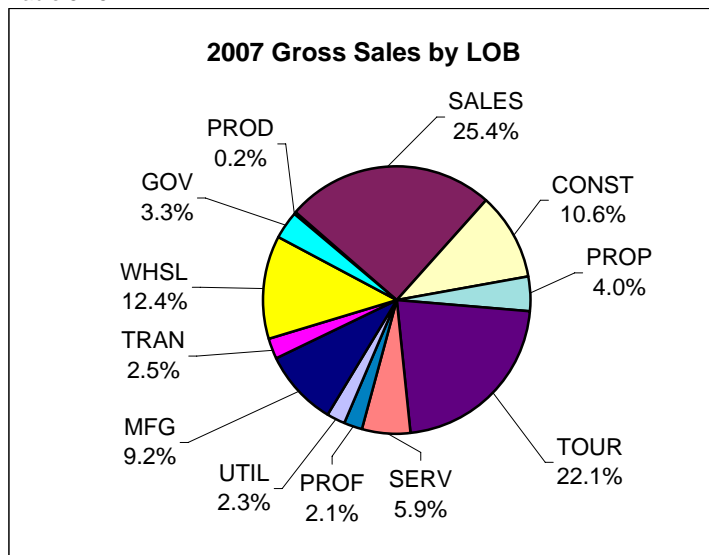

Chart 5.11

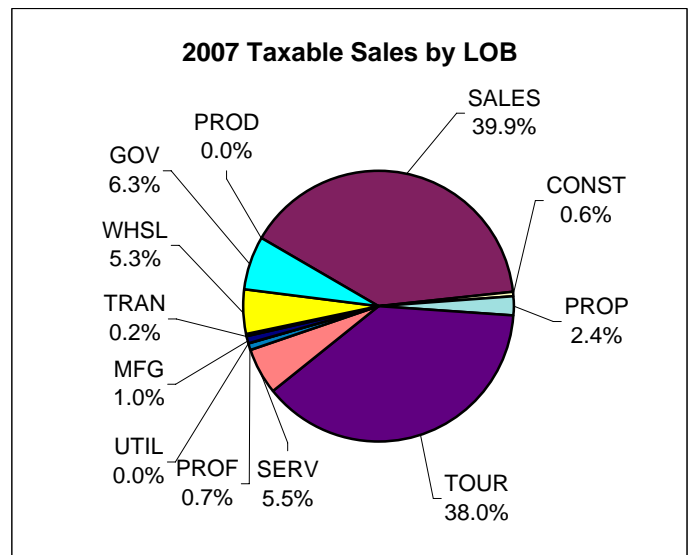

Chart 5.12

Seward TAXABLE Sales by Line of Business by Quarter - 2007 - in \$					
LOB	1st Quarter	2nd Quarter	3rd Quarter	4th Quarter	Total
Resource Production	0	500	0	0	500
Sales	5,459,433	11,649,440	17,213,707	6,485,560	40,808,140
Construction	136,277	179,192	145,599	160,333	621,401
Property	379,647	680,497	881,813	484,735	2,426,692
Tourism	1,376,173	12,342,081	23,833,459	1,341,551	38,893,264
Services	952,797	1,639,086	1,840,702	1,192,602	5,625,187
Professional	102,636	200,548	258,874	148,292	710,350
Utility	2,628	2,436	2,280	1,251	8,595
Manufacturing	82,345	339,519	496,203	128,443	1,046,510
Transportation & Warehousing	20,125	54,168	75,344	33,175	182,812
Wholesale	954,371	1,399,512	2,264,390	846,894	5,465,167
Government	1,403,466	1,553,483	1,649,505	1,860,654	6,467,108
TOTAL	10,869,898	30,040,462	48,661,876	12,683,490	102,255,726

Table 5.16

Seward Sales

Seward GROSS Sales by Line of Business by Quarter - 2006 - in \$					
LOB	1st Quarter	2nd Quarter	3rd Quarter	4th Quarter	Total
Resource Production	78	946	0	48,714	49,738
Sales	6,534,504	12,422,602	17,874,031	7,570,055	44,401,192
Construction	1,811,963	7,490,563	9,617,755	20,646,981	39,567,262
Property	1,749,426	2,181,452	2,256,711	2,080,121	8,267,710
Tourism	1,509,869	11,911,893	23,853,680	2,199,001	39,474,443
Services	1,644,851	2,380,422	2,767,202	1,988,097	8,780,572
Professional	924,106	917,531	1,155,139	1,828,168	4,824,944
Utility	751,746	964,113	1,230,113	1,055,935	4,001,907
Manufacturing	1,139,374	3,303,152	4,230,878	2,152,379	10,825,783
Transportation & Warehousing	342,636	1,185,855	2,286,927	531,208	4,346,626
Wholesale	3,994,826	6,886,194	8,673,074	8,103,644	27,657,738
Government	1,297,827	1,447,992	1,647,369	1,766,151	6,159,339
TOTAL	21,701,206	51,092,715	75,592,879	49,970,454	198,357,254

Table 5.17

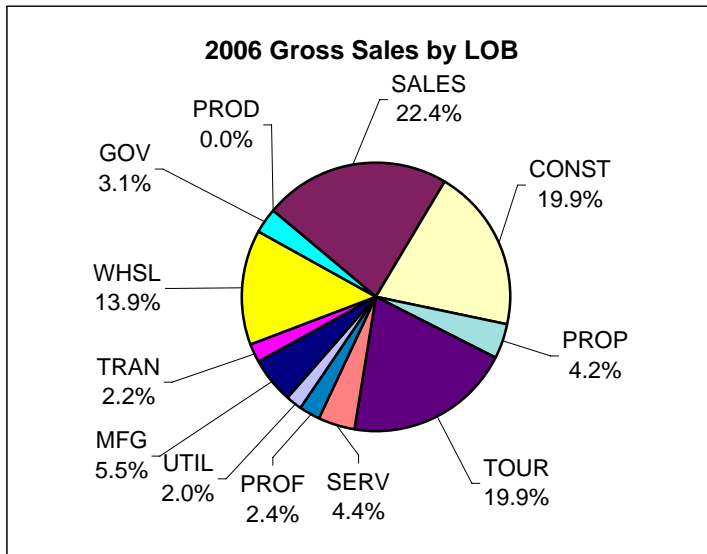

Chart 5.13

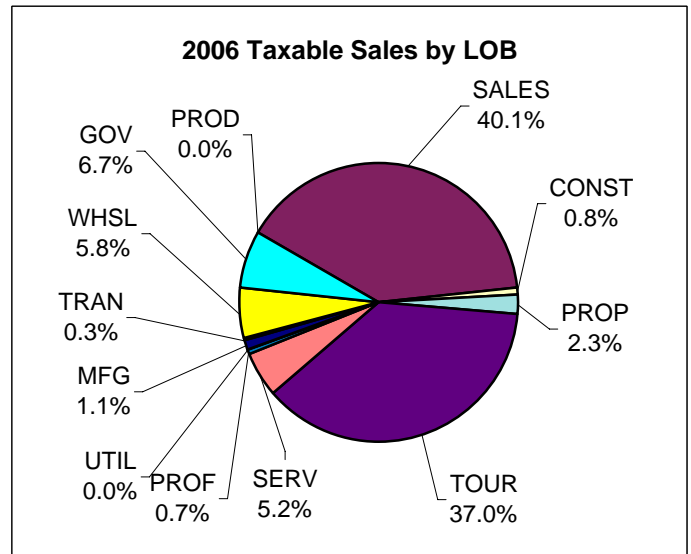

Chart 5.14

Seward TAXABLE Sales by Line of Business by Quarter - 2006 - in \$					
LOB	1st Quarter	2nd Quarter	3rd Quarter	4th Quarter	Total
Resource Production	78	946	0	0	1,024
Sales	5,117,824	10,499,840	14,941,849	5,989,723	36,549,236
Construction	147,435	200,146	165,744	184,521	697,846
Property	348,743	518,383	752,424	474,893	2,094,443
Tourism	1,321,074	10,552,821	20,474,137	1,363,185	33,711,217
Services	879,420	1,325,319	1,444,757	1,120,842	4,770,338
Professional	109,291	218,495	222,174	122,894	672,854
Utility	1,775	3,413	250	2,745	8,183
Manufacturing	83,187	325,115	484,057	86,884	979,243
Transportation & Warehousing	9,797	117,314	103,575	34,452	265,138
Wholesale	854,211	1,386,431	2,201,861	810,870	5,253,373
Government	1,297,827	1,447,992	1,647,369	1,693,871	6,087,059
TOTAL	10,170,662	26,596,215	42,438,197	11,884,880	91,089,954

Table 5.18

Seward Sales

Seward Annual Gross Sales by Quarter - in \$						
	1st Quarter	2nd Quarter	3rd Quarter	4th Quarter	Total	Annual Change
1995	17,305,724	31,740,326	49,703,768	28,713,985	127,463,803	
1996	22,782,553	35,228,909	48,116,743	27,720,437	133,848,642	5.0%
1997	23,787,658	38,959,842	54,552,242	28,247,933	145,547,675	8.7%
1998	22,948,971	35,050,219	50,480,063	24,026,995	132,506,248	-9.0%
1999	23,356,887	36,041,325	50,509,645	20,248,664	130,156,521	-1.8%
2000	19,087,797	38,017,519	57,262,889	27,790,366	142,158,571	9.2%
2001	20,537,710	44,452,278	62,874,759	20,503,354	148,368,101	4.4%
2002	22,954,013	40,385,376	56,721,649	22,308,588	142,369,626	-4.0%
2003	20,935,184	46,984,153	61,708,185	27,334,414	156,961,936	10.2%
2004	21,175,289	42,749,272	63,729,559	38,362,822	166,016,942	5.8%
2005	26,472,186	58,409,308	70,009,818	34,213,681	189,104,993	13.9%
2006	21,701,206	51,092,715	75,592,879	49,970,454	198,357,254	4.9%
2007	25,608,135	56,608,855	78,382,897	34,648,367	195,248,254	-1.6%
2008	26,506,069	59,814,396	89,445,765	38,808,545	214,574,775	9.9%
Change	3.5%	5.7%	14.1%	12.0%	9.9%	

Table 5.19

Seward Annual Taxable Sales by Quarter - in \$						
	1st Quarter	2nd Quarter	3rd Quarter	4th Quarter	Total	Annual Change
1995	7,674,012	16,721,303	22,898,202	8,461,870	55,755,387	
1996	8,027,358	16,410,250	24,077,648	8,681,685	57,196,941	2.6%
1997	8,770,990	16,994,442	26,208,216	10,542,376	62,516,024	9.3%
1998	8,541,911	19,372,356	29,591,398	9,772,599	67,278,264	7.6%
1999	9,218,678	19,907,186	31,789,068	10,557,767	71,472,699	6.2%
2000	9,374,360	21,161,398	32,904,973	10,544,695	73,985,426	3.5%
2001	9,073,993	21,553,264	33,591,833	10,007,501	74,226,591	0.3%
2002	9,051,044	22,176,474	34,338,060	10,025,144	75,590,722	1.8%
2003	9,284,504	22,072,081	34,702,846	10,289,302	76,348,733	1.0%
2004	9,494,764	22,991,903	36,892,269	10,388,272	79,767,208	4.5%
2005	10,094,338	25,309,646	40,943,244	11,401,775	87,749,003	10.0%
2006	10,170,662	26,596,215	42,438,197	11,884,880	91,089,954	3.8%
2007	10,869,898	30,040,462	48,661,876	12,683,490	102,255,726	12.3%
2008	11,339,653	30,194,399	50,389,355	13,080,362	105,003,769	2.7%
Change	4.3%	0.5%	3.5%	3.1%	2.7%	

Table 5.20

Seward Annual Non-Taxable Sales by Quarter - in \$						
	1st Quarter	2nd Quarter	3rd Quarter	4th Quarter	Total	Annual Change
1995	9,631,712	15,019,023	26,805,566	20,252,115	71,708,416	
1996	14,755,195	18,818,659	24,039,095	19,038,752	76,651,701	6.9%
1997	15,016,668	21,965,400	28,344,026	17,705,557	83,031,651	8.3%
1998	14,407,060	15,677,863	20,888,665	14,254,396	65,227,984	-21.4%
1999	14,138,209	16,134,139	18,720,577	9,690,897	58,683,822	-10.0%
2000	9,713,437	16,856,121	24,357,916	17,245,671	68,173,145	16.2%
2001	11,463,717	22,899,014	29,282,926	10,495,853	74,141,510	8.8%
2002	13,902,969	18,208,902	22,383,589	12,283,444	66,778,904	-9.9%
2003	11,650,680	24,912,072	27,005,339	17,045,112	80,613,203	20.7%
2004	11,680,525	19,757,369	26,837,290	27,974,550	86,249,734	7.0%
2005	16,377,848	33,099,662	29,066,574	22,811,906	101,355,990	17.5%
2006	11,530,544	24,496,500	33,154,682	38,085,574	107,267,300	5.8%
2007	14,738,237	26,568,393	29,721,021	21,964,877	92,992,528	-13.3%
2008	15,166,416	29,619,997	39,056,410	25,728,183	109,571,006	17.8%
Change	2.9%	11.5%	31.4%	17.1%	17.8%	

Table 5.21

Seward Construction Permits

Seward 4th Quarter Permit VALUES by Type - 2002-2008 - in \$								
	2002	2003	2004	2005	2006	2007	2008	Annual Change
Residential New	0	0	0	1,500	0	0	0	0.0%
Residential Alter/Add	19,800	50,000	8,000	40,457	13,000	118,000	45,000	-61.9%
Commercial New	2,100,000	5,000	0	60,000	1,896,300	18,000,000	125,000	-99.3%
Commercial Alter/Add	113,000	517,500	251,350	4,900	35,000	21,500	192,000	0.0%
Total	2,232,800	572,500	259,350	106,857	1,944,300	18,139,500	362,000	-98.0%
Annual Change		-74.4%	-54.7%	-58.8%	1719.5%	833.0%	-98.0%	

Table 5.22

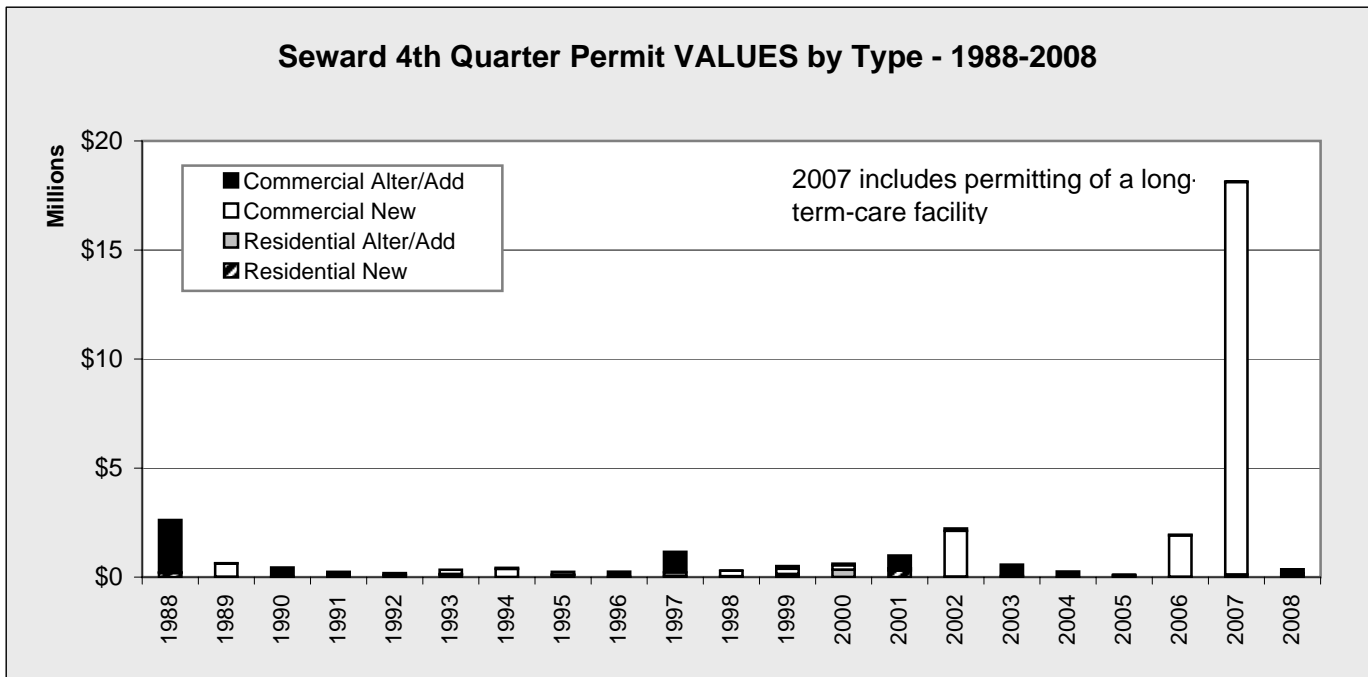

Chart 5.15

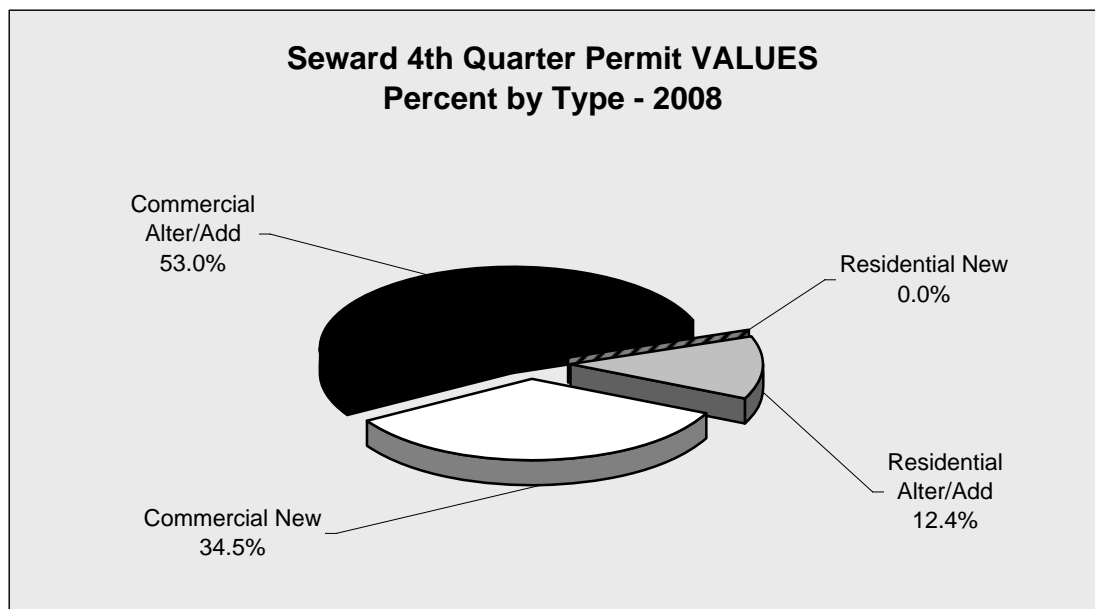

Chart 5.16

Seward Construction Permits

Seward 4th Quarter Permit VOLUME by Type - 2002-2008

	2002	2003	2004	2005	2006	2007	2008	Annual Change
Residential New	0	0	0	1	0	0	0	0.0%
Residential Alter/Add	4	1	1	3	1	4	3	-25.0%
Commercial New	3	1	0	1	4	1	1	0.0%
Commercial Alter/Add	4	9	6	2	1	4	5	25.0%
Total	11	11	7	7	6	9	9	0.0%
Annual Change		0.0%	-36.4%	0.0%	-14.3%	50.0%	0.0%	

Table 5.23

Seward 4th Quarter Permit VOLUME by Type - 1988-2008

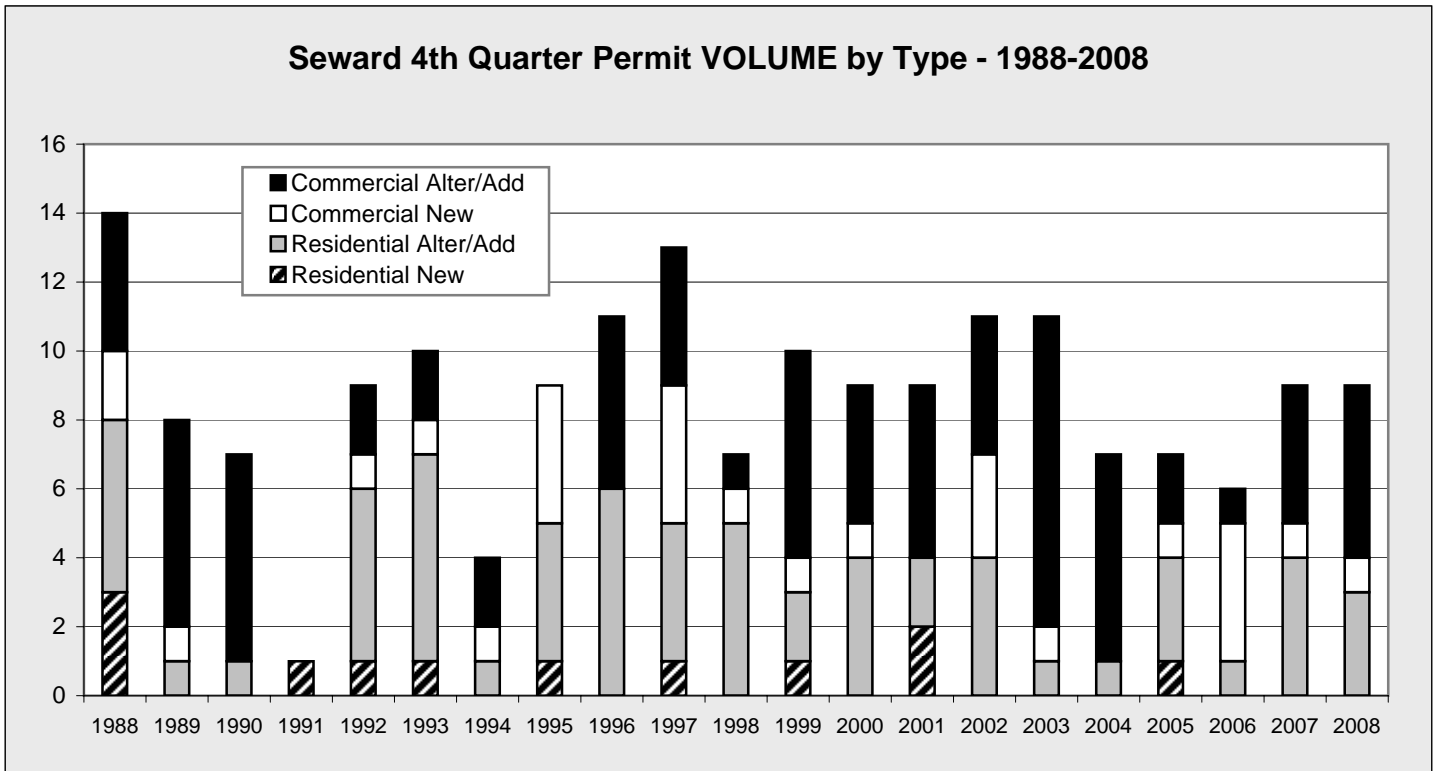

Chart 5.17

Seward 4th Quarter Permit VOLUME Percent by Type - 2008

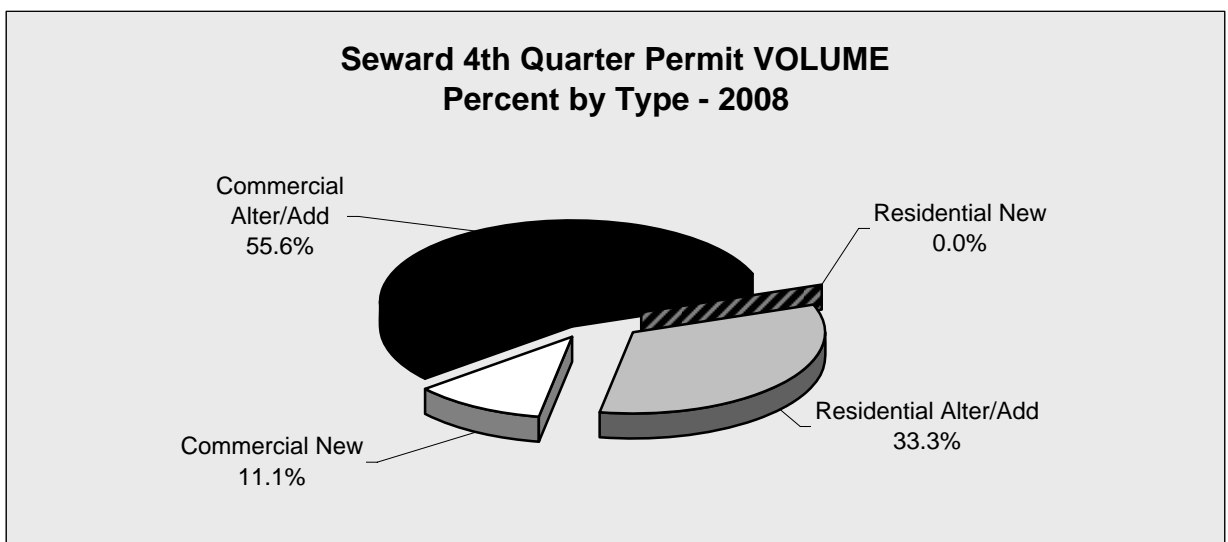

Chart 5.18

Seward Construction Permits

Seward Annual Permit VALUES by Type - 2002-2008 - in \$								
	2002	2003	2004	2005	2006	2007	2008	Annual Change
Residential New	725,000	1,077,500	2,130,000	1,767,500	1,118,000	252,354	1,700,000	573.7%
Residential Alter/Add	242,008	294,500	500,400	134,738	86,392	177,400	228,879	29.0%
Commercial New	6,144,730	4,290,000	13,018,800	425,720	22,396,300	18,216,013	325,000	-98.2%
Commercial Alter/Add	798,965	2,320,765	2,061,950	535,185	1,936,557	2,450,158	578,500	-76.4%
Total	7,910,703	7,982,765	17,711,150	2,863,143	25,537,249	21,095,925	2,832,379	-86.6%
Annual Change		0.9%	121.9%	-83.8%	791.9%	-17.4%	-86.6%	

Table 5.24

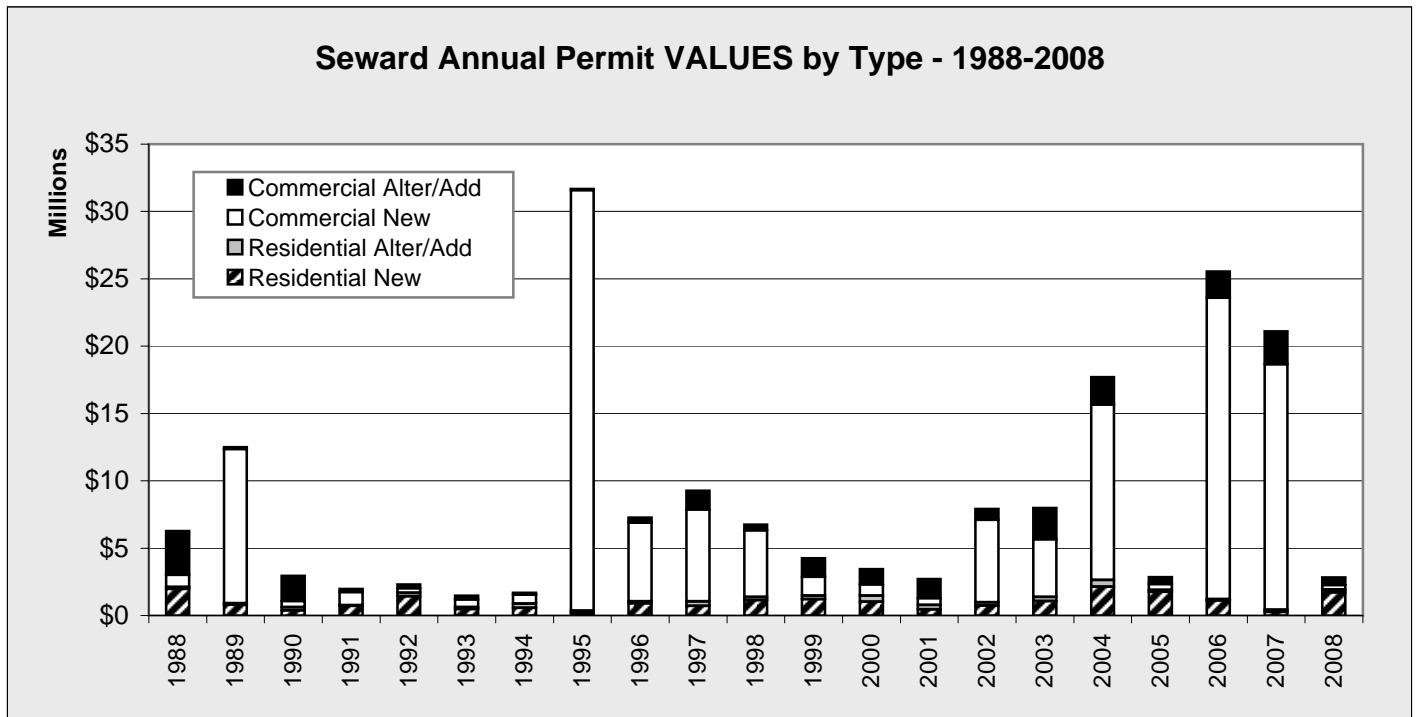

Chart 5.19

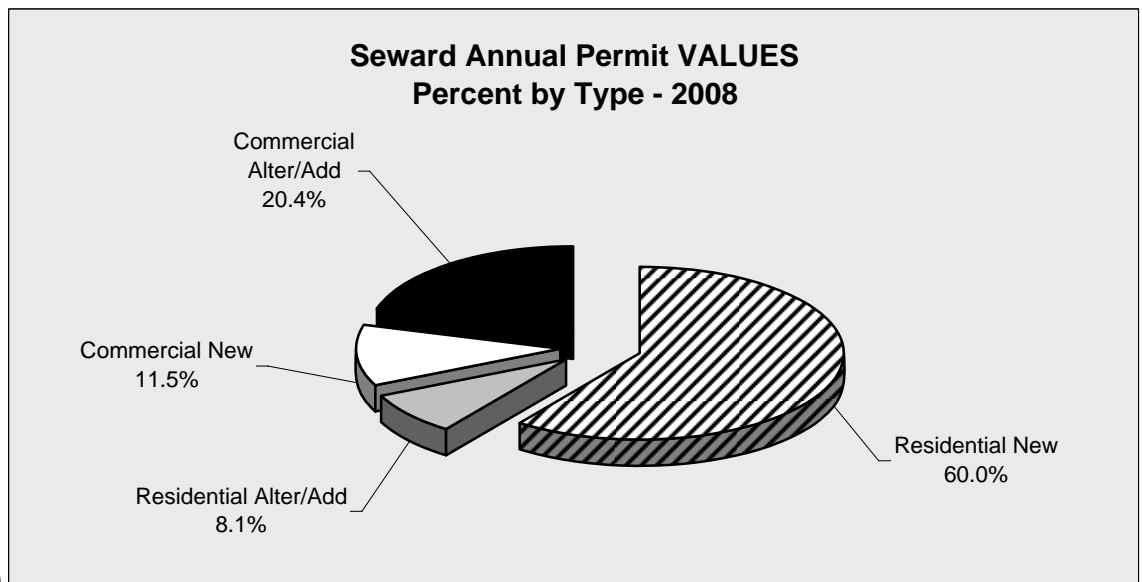

Chart 5.20

Seward Construction Permits

Seward Annual Permit VOLUME by Type - 2002-2008

	2002	2003	2004	2005	2006	2007	2008	Annual Change
Residential New	4	8	12	11	8	2	3	50.0%
Residential Alter/Add	25	11	15	19	13	12	13	8.3%
Commercial New	8	7	4	10	17	3	2	-33.3%
Commercial Alter/Add	27	24	23	14	17	20	12	-40.0%
Total	64	50	54	54	55	37	30	-18.9%
Annual Change		-21.9%	8.0%	0.0%	1.9%	-32.7%	-18.9%	

Table 5.25

Seward Annual Permit VOLUME by Type - 1988-2008

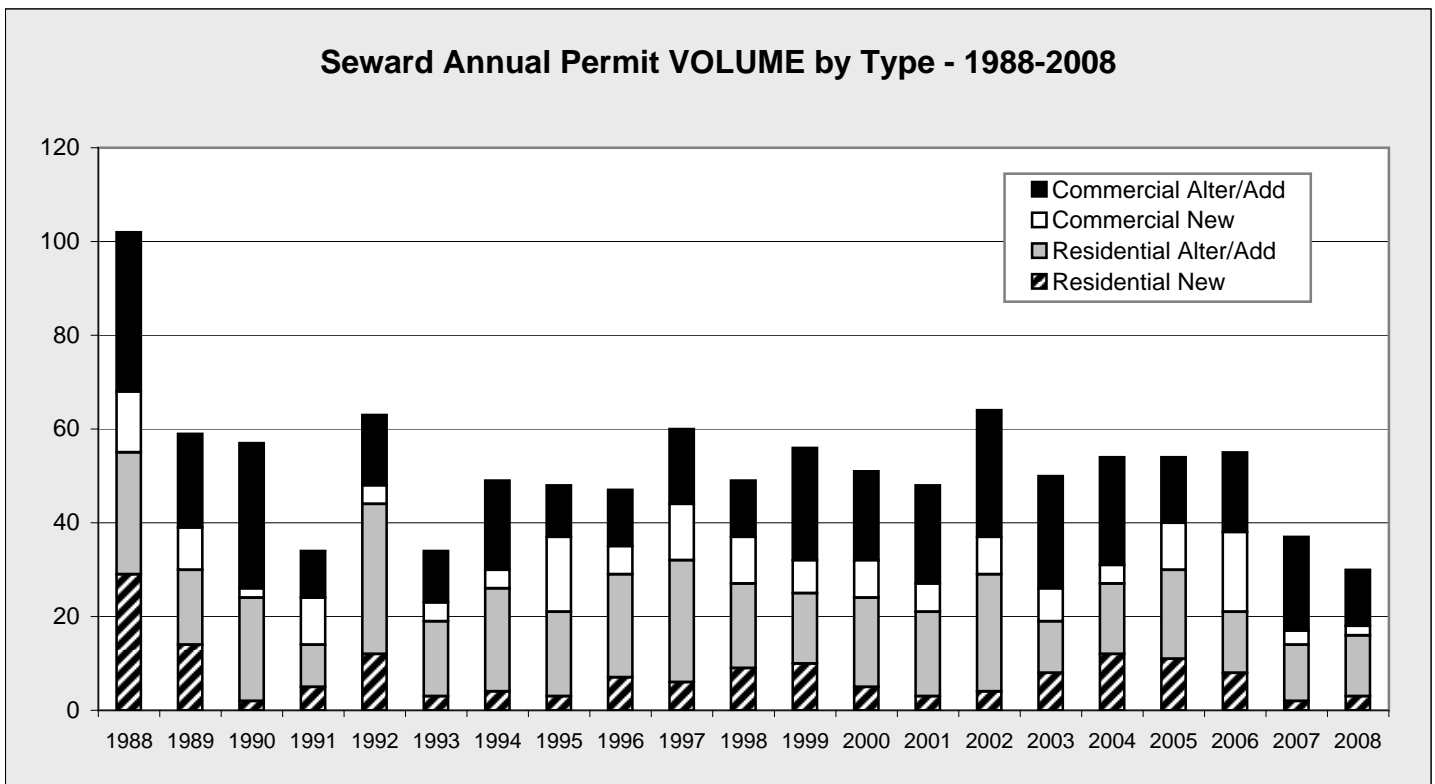

Chart 5.21

**Seward Annual Permit VOLUME
Percent by Type - 2008**

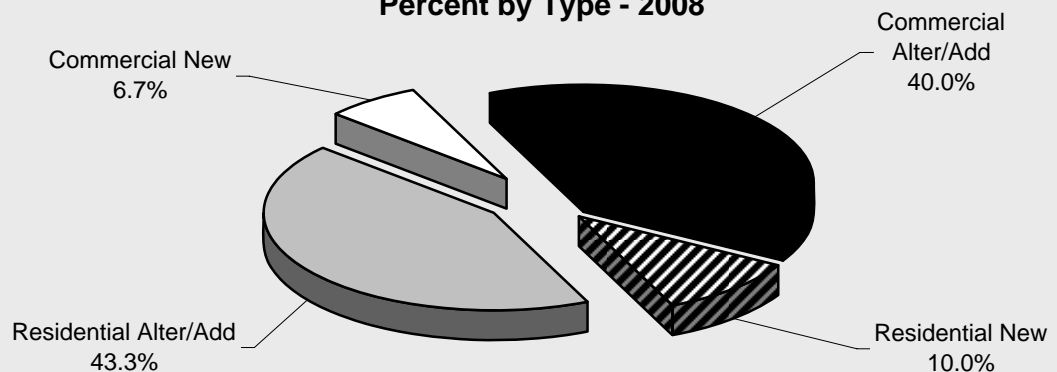

Chart 5.22

Seward Construction Permits

Seward Annual Permit VALUE by Type by Quarter - 2001-2008 - in \$					
	1st Quarter	2nd Quarter	3rd Quarter	4th Quarter	Total
2001					
Residential - New	0	0	150,000	300,000	450,000
Residential - Add/Alter	30,200	73,000	136,014	105,000	344,214
Commercial - New	0	155,000	331,028	0	486,028
Commercial - Add/Alter	386,500	438,239	25,000	587,000	1,436,739
TOTAL	416,700	666,239	642,042	992,000	2,716,981
2002					
Residential - New	120,000	400,000	205,000	0	725,000
Residential - Add/Alter	25,496	169,157	27,555	19,800	242,008
Commercial - New	0	3,294,730	750,000	2,100,000	6,144,730
Commercial - Add/Alter	335,944	25,000	325,021	113,000	798,965
TOTAL	481,440	3,888,887	1,307,576	2,232,800	7,910,703
2003					
Residential - New	118,000	215,000	744,500	0	1,077,500
Residential - Add/Alter	57,500	100,000	87,000	50,000	294,500
Commercial - New	72,000	3,313,000	900,000	5,000	4,290,000
Commercial - Add/Alter	1,657,855	44,010	101,400	517,500	2,320,765
TOTAL	1,905,355	3,672,010	1,832,900	572,500	7,982,765
2004					
Residential - New	0	873,000	1,257,000	0	2,130,000
Residential - Add/Alter	48,000	144,900	299,500	8,000	500,400
Commercial - New	7,500,000	5,000,000	518,800	0	13,018,800
Commercial - Add/Alter	193,600	1,426,000	191,000	251,350	2,061,950
TOTAL	7,741,600	7,443,900	2,266,300	259,350	17,711,150
2005					
Residential - New	923,000	388,000	455,000	1,500	1,767,500
Residential - Add/Alter	3,300	84,220	6,761	40,457	134,738
Commercial - New	6,000	271,320	88,400	60,000	425,720
Commercial - Add/Alter	240,000	15,000	275,285	4,900	535,185
TOTAL	1,172,300	758,540	825,446	106,857	2,863,143
2006					
Residential - New	0	415,000	703,000	0	1,118,000
Residential - Add/Alter	1,000	65,200	7,192	13,000	86,392
Commercial - New	0	800,000	19,700,000	1,896,300	22,396,300
Commercial - Add/Alter	621,217	904,472	375,868	35,000	1,936,557
TOTAL	622,217	2,184,672	20,786,060	1,944,300	25,537,249
2007					
Residential - New	0	82,354	170,000	0	252,354
Residential - Add/Alter	0	13,000	46,400	118,000	177,400
Commercial - New	208,513	0	7,500	18,000,000	18,216,013
Commercial - Add/Alter	594,725	1,792,933	41,000	21,500	2,450,158
TOTAL	803,238	1,888,287	264,900	18,139,500	21,095,925
2008					
Residential - New	0	1,700,000	0	0	1,700,000
Residential - Add/Alter	45,415	128,964	9,500	45,000	228,879
Commercial - New	0	0	200,000	125,000	325,000
Commercial - Add/Alter	364,000	15,500	7,000	192,000	578,500
TOTAL	409,415	1,844,464	216,500	362,000	2,832,379

Table 5.26

Seward Construction Permits

Seward Annual Permit VOLUME by Type by Quarter - 2001-2008					
	1st Quarter	2nd Quarter	3rd Quarter	4th Quarter	Total
2001					
Residential - New	0	0	1	2	3
Residential - Add/Alter	4	3	9	2	18
Commercial - New	0	3	3	0	6
Commercial - Add/Alter	7	8	1	5	21
TOTAL	11	14	14	9	48
2002					
Residential - New	1	1	2	0	4
Residential - Add/Alter	3	15	3	4	25
Commercial - New	0	4	1	3	8
Commercial - Add/Alter	6	9	8	4	27
TOTAL	10	29	14	11	64
2003					
Residential - New	1	2	5	0	8
Residential - Add/Alter	2	3	5	1	11
Commercial - New	1	4	1	1	7
Commercial - Add/Alter	7	4	4	9	24
TOTAL	11	13	15	11	50
2004					
Residential - New	0	4	8	0	12
Residential - Add/Alter	2	7	5	1	15
Commercial - New	1	1	2	0	4
Commercial - Add/Alter	4	9	4	6	23
TOTAL	7	21	19	7	54
2005					
Residential - New	4	3	3	1	11
Residential - Add/Alter	2	9	5	3	19
Commercial - New	2	5	2	1	10
Commercial - Add/Alter	4	2	6	2	14
TOTAL	12	19	16	7	54
2006					
Residential - New	0	3	5	0	8
Residential - Add/Alter	1	7	4	1	13
Commercial - New	0	11	2	4	17
Commercial - Add/Alter	6	2	8	1	17
TOTAL	7	23	19	6	55
2007					
Residential - New	0	1	1	0	2
Residential - Add/Alter	0	2	6	4	12
Commercial - New	1	0	1	1	3
Commercial - Add/Alter	6	8	2	4	20
TOTAL	7	11	10	9	37
2008					
Residential - New	0	3	0	0	3
Residential - Add/Alter	1	7	2	3	13
Commercial - New	0	0	1	1	2
Commercial - Add/Alter	4	2	1	5	12
TOTAL	5	12	4	9	30

Table 5.27

Soldotna Sales

Soldotna Fourth Quarter GROSS Sales by Line of Business - 2003-2008 - in \$								
LOB	2003	2004	2005	2006	2007	2008	Annual Percent Change	Annual Amount Change
PROD	99,893	160,292	16,081	145,703	54,581	49,185	-9.9%	-5,396
SALES	49,640,820	52,595,533	50,177,023	56,141,794	61,258,905	74,769,111	22.1%	13,510,206
CONST	5,427,760	9,186,599	43,428,145	46,179,935	18,986,143	9,396,597	-50.5%	-9,589,546
PROP	4,154,494	4,607,295	3,776,775	5,277,792	5,232,397	4,540,667	-13.2%	-691,730
TOUR	4,613,237	4,750,528	5,155,057	5,266,645	4,915,979	1,035,504	-78.9%	-3,880,475
SERV	4,458,159	4,892,960	4,960,795	6,068,471	8,464,222	6,549,038	-22.6%	-1,915,184
PROF	2,501,007	7,214,508	7,694,574	7,668,527	6,820,710	8,804,448	29.1%	1,983,738
UTIL	1,840,025	1,936,789	2,296,442	3,043,343	2,769,007	3,668,034	32.5%	899,027
MANU	2,114,133	1,827,915	2,996,668	2,750,085	2,611,454	2,424,265	-7.2%	-187,189
TRAN	43,755	769,415	1,094,995	917,536	1,485,613	1,724,660	16.1%	239,047
WHLS	7,055,205	6,661,231	6,671,450	6,494,786	4,004,963	3,758,557	-6.2%	-246,406
GOV	206,630	219,380	236,866	262,805	265,837	271,449	2.1%	5,612
TOTAL	82,155,118	94,822,445	128,504,871	140,217,422	116,869,811	116,991,515	0.1%	121,704

Table 6.1 For complete listing of Lines of Business, see page 13

Soldotna 4th Quarter GROSS Sales	
2003	82,155,118
2004	94,822,445
2005	128,504,871
2006	140,217,422
2007	116,869,811
2008	116,991,515

Table 6.2

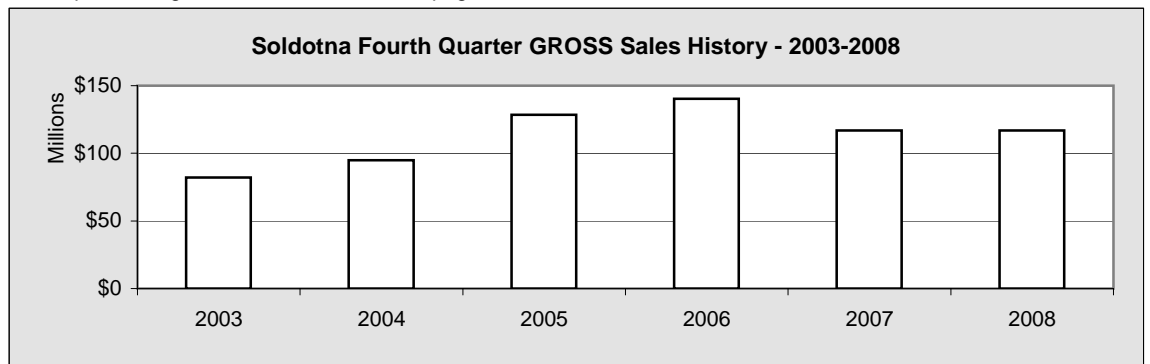

Chart 6.1

Soldotna Five Year Change Fourth Quarter GROSS Sales		
	2003	2008
PROD	99,893	49,185
SALES	49,640,820	74,769,111
CONST	5,427,760	9,396,597
PROP	4,154,494	4,540,667
TOUR	4,613,237	1,035,504
SERV	4,458,159	6,549,038
PROF	2,501,007	8,804,448
UTIL	1,840,025	3,668,034
MANU	2,114,133	2,424,265
TRAN	43,755	1,724,660
WHLS	7,055,205	3,758,557
GOV	206,630	271,449
TOTAL	82,155,118	116,991,515

Table 6.3

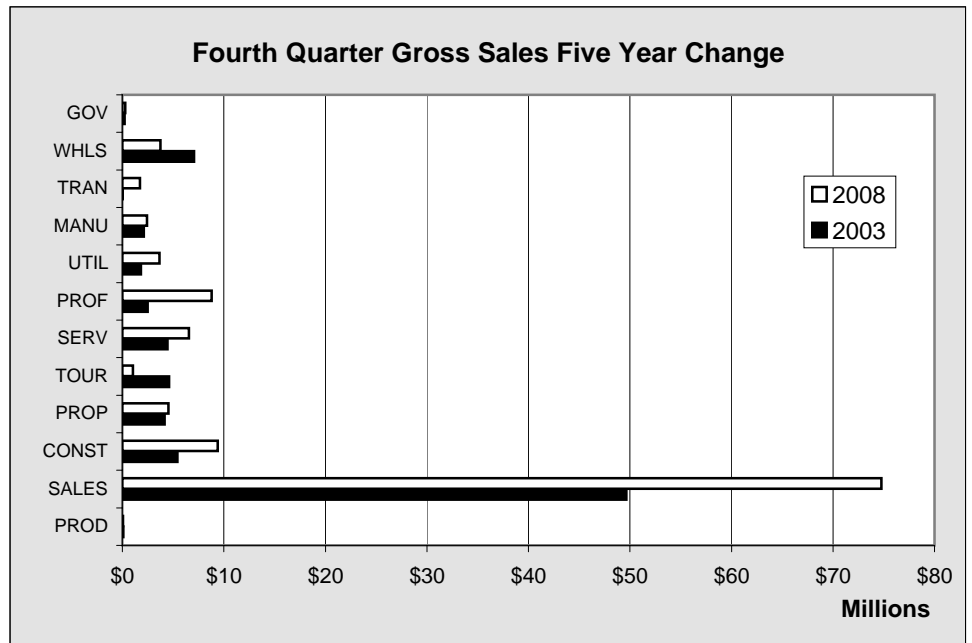

Chart 6.2

Soldotna Sales

Soldotna Fourth Quarter TAXABLE Sales by Line of Business - 2003-2008 - in \$								
LOB	2003	2004	2005	2006	2007	2008	Annual Percent Change	Annual Amount Change
PROD	9,590	9,957	5,653	5,446	5,716	9,508	66.3%	3,792
SALES	34,097,100	34,777,272	36,353,588	39,439,020	42,499,615	47,997,606	12.9%	5,497,991
CONST	276,369	256,818	244,220	247,023	281,056	249,333	-11.3%	-31,723
PROP	1,432,195	1,634,255	1,685,005	1,739,613	2,356,418	1,891,415	-19.7%	-465,003
TOUR	4,330,455	4,393,077	4,668,855	4,742,818	4,399,684	740,589	-83.2%	-3,659,095
SERV	3,505,531	3,539,850	3,656,386	4,302,309	4,637,172	4,739,383	2.2%	102,211
PROF	829,387	777,605	749,401	863,607	1,048,329	1,065,730	1.7%	17,401
UTIL	1,003,838	1,062,389	1,231,331	1,504,841	1,410,310	1,737,664	23.2%	327,354
MANU	126,482	112,023	823,816	643,127	253,947	159,379	-37.2%	-94,568
TRAN	15,966	15,807	35,242	25,948	125,178	21,923	-82.5%	-103,255
WHLS	750,193	710,241	734,824	692,442	875,942	751,820	-14.2%	-124,122
GOV	181,234	191,682	207,065	225,376	219,931	223,504	1.6%	3,573
TOTAL	46,558,340	47,480,976	50,395,386	54,431,570	58,113,298	59,587,854	2.5%	1,474,556

Table 6.4

For complete listing of Lines of Business, see page 13

4th Quarter TAXABLE Sales	
2003	46,558,340
2004	47,480,976
2005	50,395,386
2006	54,431,570
2007	58,113,298
2008	59,587,854

Table 6.5

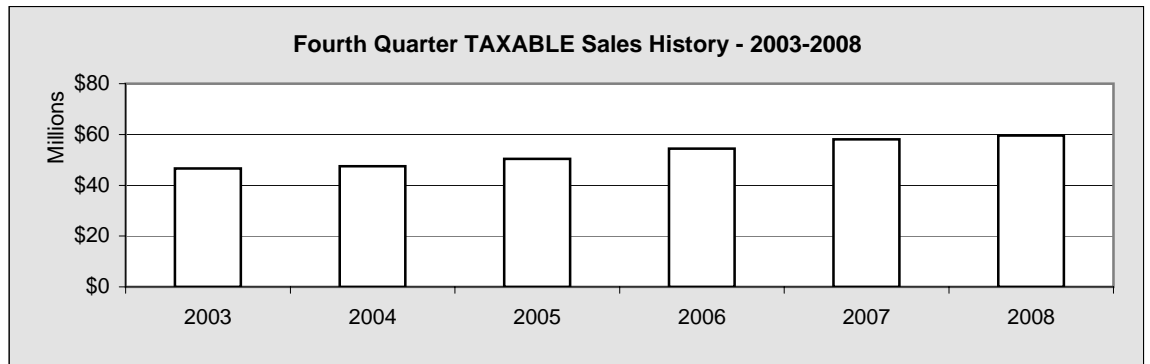

Chart 6.3

Five Year Change Fourth Quarter TAXABLE Sales		
	2003	2008
PROD	9,590	9,508
SALES	34,097,100	47,997,606
CONST	276,369	249,333
PROP	1,432,195	1,891,415
TOUR	4,330,455	740,589
SERV	3,505,531	4,739,383
PROF	829,387	1,065,730
UTIL	1,003,838	1,737,664
MANU	126,482	159,379
TRAN	15,966	21,923
WHLS	750,193	751,820
GOV	181,234	223,504
TOTAL	46,558,340	59,587,854

Table 6.6

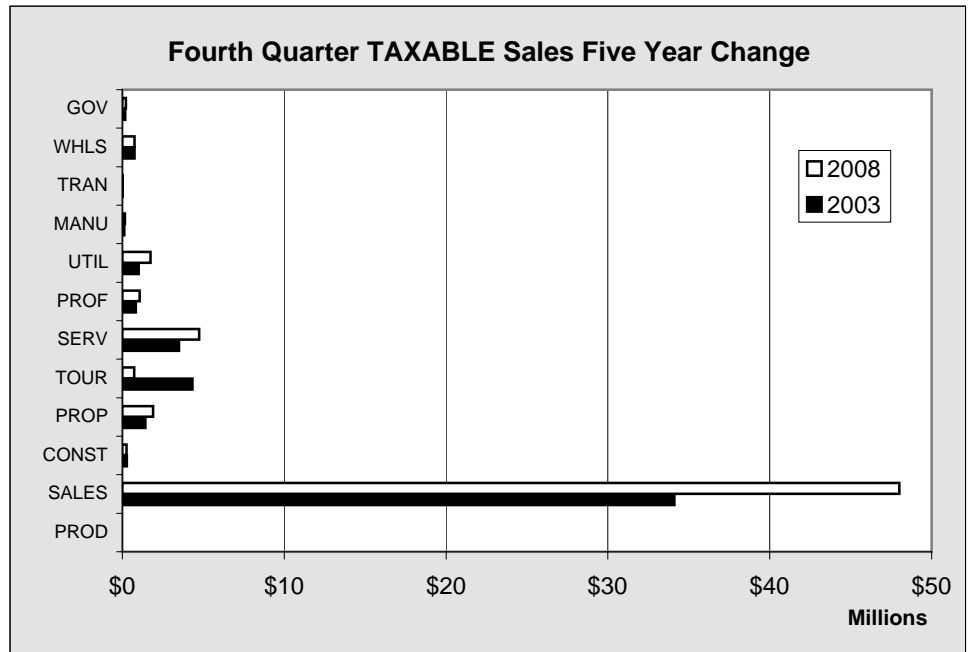

Chart 6.4

Soldotna Sales

Soldotna Annual GROSS Sales by Line of Business - 2003-2008 - in \$								
LOB	2003	2004	2005	2006	2007	2008	Annual Percent Change	Annual Amount Change
PROD	425,497	501,400	438,718	213,456	920,490	276,855	-69.9%	-643,635
SALES	201,426,315	212,835,934	219,656,619	230,020,343	247,381,780	305,621,161	23.5%	58,239,381
CONST	18,592,599	25,977,708	60,647,837	73,482,023	43,636,826	33,873,057	-22.4%	-9,763,769
PROP	15,014,093	15,977,058	15,638,823	18,401,722	18,875,156	19,612,870	3.9%	737,714
TOUR	22,794,234	24,557,709	26,157,699	29,550,690	26,893,691	8,637,044	-67.9%	-18,256,647
SERV	18,034,222	19,883,143	19,472,878	23,474,072	32,332,923	29,408,020	-9.0%	-2,924,903
PROF	10,359,952	13,652,017	14,717,603	16,102,094	15,707,527	19,551,347	24.5%	3,843,820
UTIL	6,868,788	7,753,204	8,447,844	10,027,542	11,047,821	12,437,580	12.6%	1,389,759
MANU	10,450,535	7,146,598	10,076,540	10,866,104	11,886,354	10,015,150	-15.7%	-1,871,204
TRAN	533,819	3,017,321	4,736,701	4,140,863	5,695,881	10,750,934	88.7%	5,055,053
WHLS	32,548,455	28,991,155	15,036,051	15,456,999	13,769,409	14,033,336	1.9%	263,927
GOV	857,491	965,632	1,006,150	1,119,273	1,147,529	1,188,534	3.6%	41,005
TOTAL	337,906,000	361,258,879	396,033,463	432,855,181	429,295,387	465,405,888	8.4%	36,110,501

Table 6.7

For complete listing of Lines of Business, see page 13

Annual GROSS Sales History	
2003	337,906,000
2004	361,258,879
2005	396,033,463
2006	432,855,181
2007	429,295,387
2008	465,405,888

Table 6.8

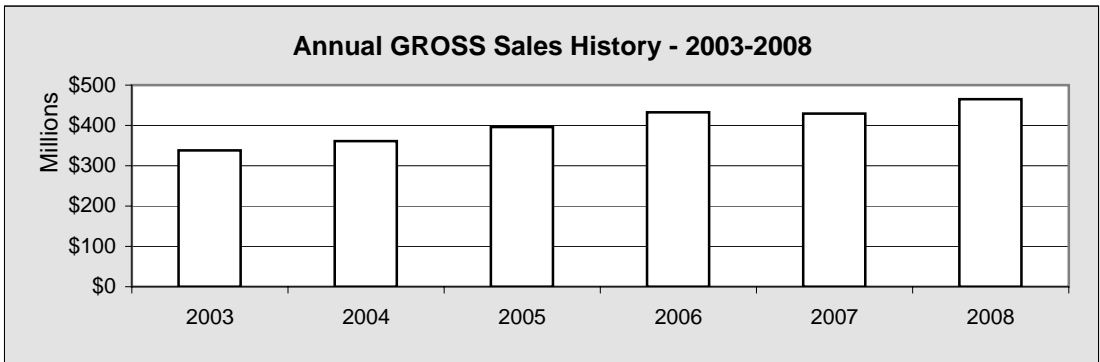

Chart 6.5

Five Year Change Annual GROSS Sales		
	2003	2008
PROD	425,497	276,855
SALES	201,426,315	305,621,161
CONST	18,592,599	33,873,057
PROP	15,014,093	19,612,870
TOUR	22,794,234	8,637,044
SERV	18,034,222	29,408,020
PROF	10,359,952	19,551,347
UTIL	6,868,788	12,437,580
MANU	10,450,535	10,015,150
TRAN	533,819	10,750,934
WHLS	32,548,455	14,033,336
GOV	857,491	1,188,534
TOTAL	337,906,000	465,405,888

Table 6.9

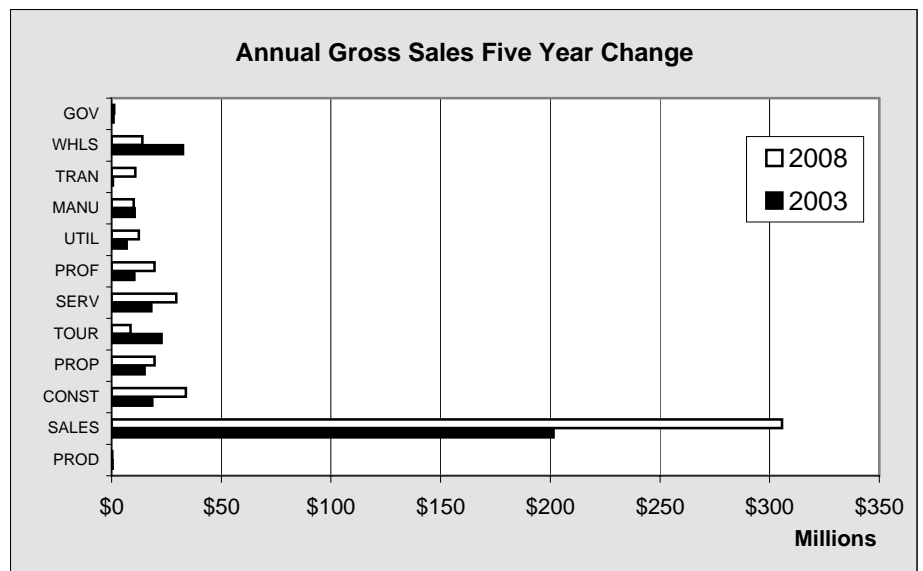

Chart 6.6

Soldotna Sales

Soldotna Annual TAXABLE Sales by Line of Business - 2003-2008 - in \$								
LOB	2003	2004	2005	2006	2007	2008	Annual Percent Change	Annual Amount Change
PROD	53,445	24,403	29,575	34,327	43,133	50,577	17.3%	7,444
SALES	135,997,009	143,250,121	152,149,810	162,055,202	175,657,256	209,999,367	19.6%	34,342,111
CONST	1,123,434	1,054,535	1,002,298	938,809	985,188	944,534	-4.1%	-40,654
PROP	6,225,915	6,558,835	6,578,222	6,825,029	8,171,789	8,204,532	0.4%	32,743
TOUR	20,772,105	21,979,858	23,398,168	25,066,602	24,042,079	6,602,437	-72.5%	-17,439,642
SERV	14,519,872	15,017,384	14,635,114	16,794,536	17,923,945	19,118,781	6.7%	1,194,836
PROF	3,665,152	3,675,592	3,591,626	4,013,780	4,398,267	5,003,549	13.8%	605,282
UTIL	3,712,214	3,898,545	4,410,657	5,169,826	5,662,440	5,932,835	4.8%	270,395
MANU	1,421,516	1,511,891	2,165,467	3,405,902	3,114,350	1,801,023	-42.2%	-1,313,327
TRAN	170,122	66,563	114,607	104,245	196,204	78,963	-59.8%	-117,241
WHLS	2,235,271	2,209,742	2,263,975	2,178,318	2,332,434	2,391,044	2.5%	58,610
GOV	731,717	812,079	870,925	958,451	968,136	967,141	-0.1%	-995
TOTAL	190,627,772	200,059,548	211,210,444	227,545,027	243,495,221	261,094,783	7.2%	17,599,562

Table 6.10

For complete listing of Lines of Business, see page 13

Annual TAXABLE Sales History	
2003	190,627,772
2004	200,059,548
2005	211,210,444
2006	227,545,027
2007	243,495,221
2008	261,094,783

Table 6.11

Chart 6.7

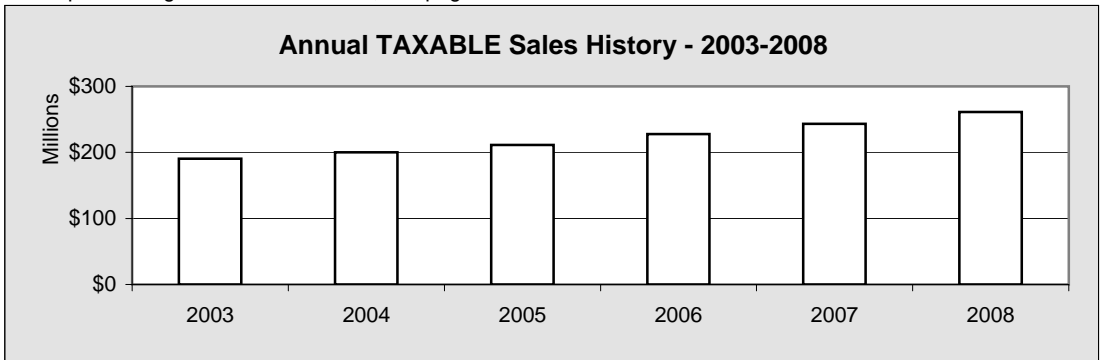

Five Year Change Annual TAXABLE Sales		
	2003	2008
PROD	53,445	50,577
SALES	135,997,009	209,999,367
CONST	1,123,434	944,534
PROP	6,225,915	8,204,532
TOUR	20,772,105	6,602,437
SERV	14,519,872	19,118,781
PROF	3,665,152	5,003,549
UTIL	3,712,214	5,932,835
MANU	1,421,516	1,801,023
TRAN	170,122	78,963
WHLS	2,235,271	2,391,044
GOV	731,717	967,141
TOTAL	190,627,772	261,094,783

Table 6.12

Chart 6.8

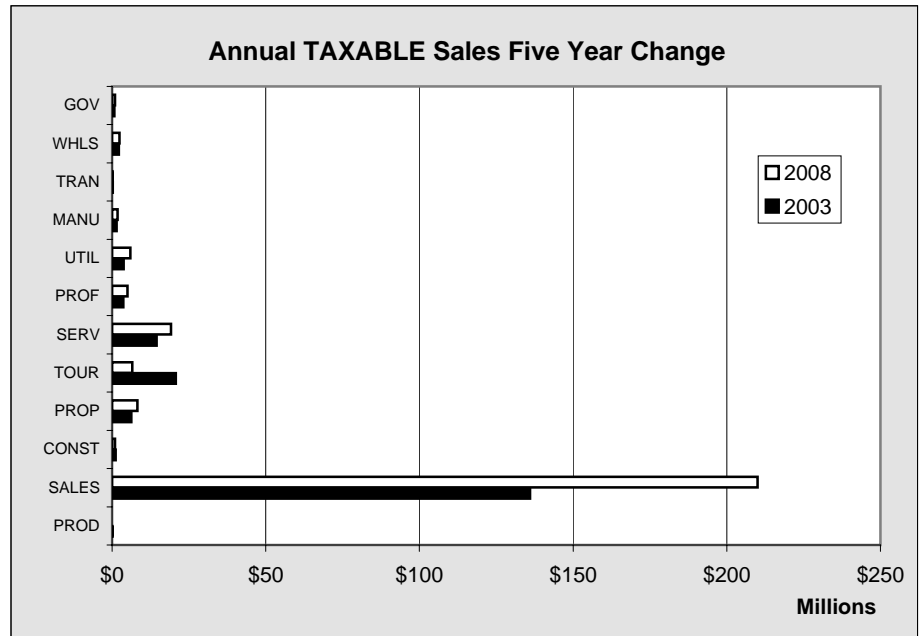

Soldotna Sales

Soldotna GROSS Sales by Line of Business by Quarter - 2008 - in \$					
LOB	1st Quarter	2nd Quarter	3rd Quarter	4th Quarter	Total
Resource Production	74,398	67,144	86,128	49,185	276,855
Sales	57,620,096	74,429,481	98,802,473	74,769,111	305,621,161
Construction	7,346,187	5,474,282	11,655,991	9,396,597	33,873,057
Property	4,301,652	5,629,677	5,140,874	4,540,667	19,612,870
Tourism	1,026,758	2,208,313	4,366,469	1,035,504	8,637,044
Services	6,611,406	8,694,118	7,553,458	6,549,038	29,408,020
Professional	3,270,102	3,617,747	3,859,050	8,804,448	19,551,347
Utility	3,763,996	2,681,735	2,323,815	3,668,034	12,437,580
Manufacturing	1,537,364	2,353,456	3,700,065	2,424,265	10,015,150
Transportation & Warehousing	1,062,540	3,573,842	4,389,892	1,724,660	10,750,934
Wholesale	2,649,179	3,420,857	4,204,743	3,758,557	14,033,336
Government	274,352	305,388	337,345	271,449	1,188,534
TOTAL	89,538,030	112,456,040	146,420,303	116,991,515	465,405,888

Table 6.13

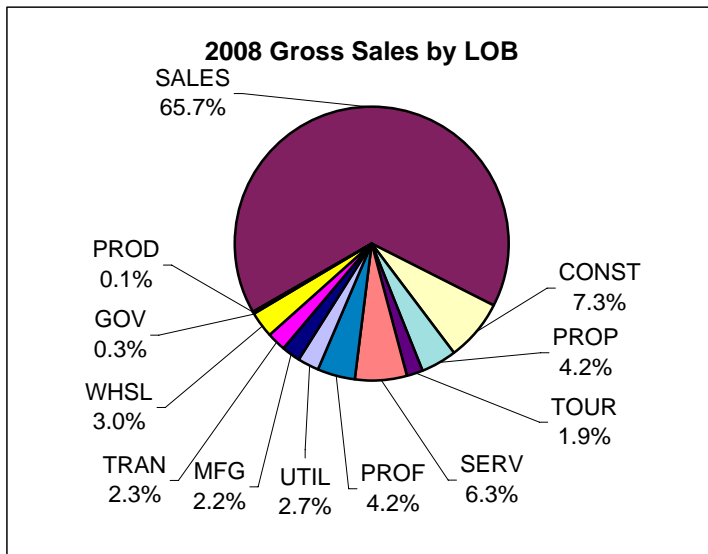

Chart 6.9

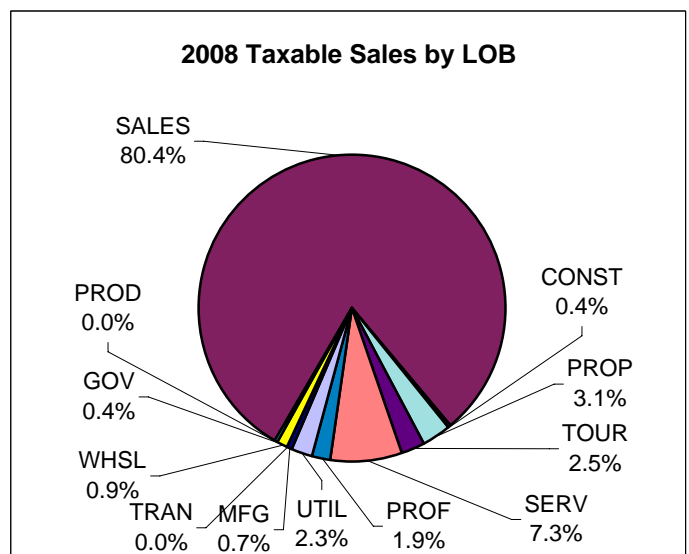

Chart 6.10

Soldotna TAXABLE Sales by Line of Business by Quarter - 2008 - in \$					
LOB	1st Quarter	2nd Quarter	3rd Quarter	4th Quarter	Total
Resource Production	3,369	17,310	20,390	9,508	50,577
Sales	36,872,041	49,975,174	75,154,546	47,997,606	209,999,367
Construction	184,451	242,024	268,726	249,333	944,534
Property	1,727,003	2,420,172	2,165,942	1,891,415	8,204,532
Tourism	792,767	1,715,773	3,353,308	740,589	6,602,437
Services	4,136,631	4,904,238	5,338,529	4,739,383	19,118,781
Professional	1,256,706	1,406,757	1,274,356	1,065,730	5,003,549
Utility	1,784,468	1,343,839	1,066,864	1,737,664	5,932,835
Manufacturing	123,233	336,282	1,182,129	159,379	1,801,023
Transportation & Warehousing	18,548	22,474	16,018	21,923	78,963
Wholesale	532,503	539,333	567,388	751,820	2,391,044
Government	228,831	255,936	258,870	223,504	967,141
TOTAL	47,660,551	63,179,312	90,667,066	59,587,854	261,094,783

Table 6.14

Soldotna Sales

Soldotna GROSS Sales by Line of Business by Quarter - 2007 - in \$					
LOB	1st Quarter	2nd Quarter	3rd Quarter	4th Quarter	Total
Resource Production	214,787	494,187	156,935	54,581	920,490
Sales	45,880,130	60,021,298	80,221,447	61,258,905	247,381,780
Construction	7,265,067	8,759,070	8,626,546	18,986,143	43,636,826
Property	4,023,704	4,458,148	5,160,907	5,232,397	18,875,156
Tourism	4,657,506	6,881,869	10,438,337	4,915,979	26,893,691
Services	5,783,803	8,786,410	9,298,488	8,464,222	32,332,923
Professional	2,766,453	3,331,477	2,788,887	6,820,710	15,707,527
Utility	3,646,985	2,351,351	2,280,478	2,769,007	11,047,821
Manufacturing	1,813,100	2,995,574	4,466,226	2,611,454	11,886,354
Transportation & Warehousing	654,875	1,050,794	2,504,599	1,485,613	5,695,881
Wholesale	2,283,909	3,495,025	3,985,512	4,004,963	13,769,409
Government	269,132	340,977	271,583	265,837	1,147,529
TOTAL	79,259,451	102,966,180	130,199,945	116,869,811	429,295,387

Table 6.15

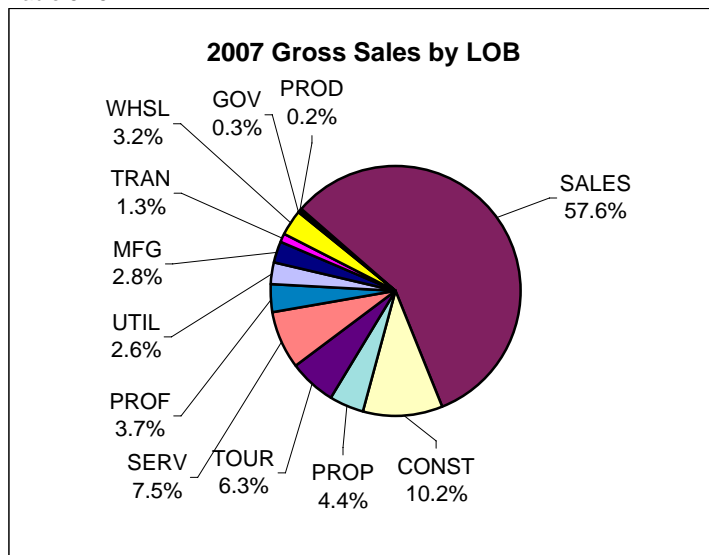

Chart 6.11

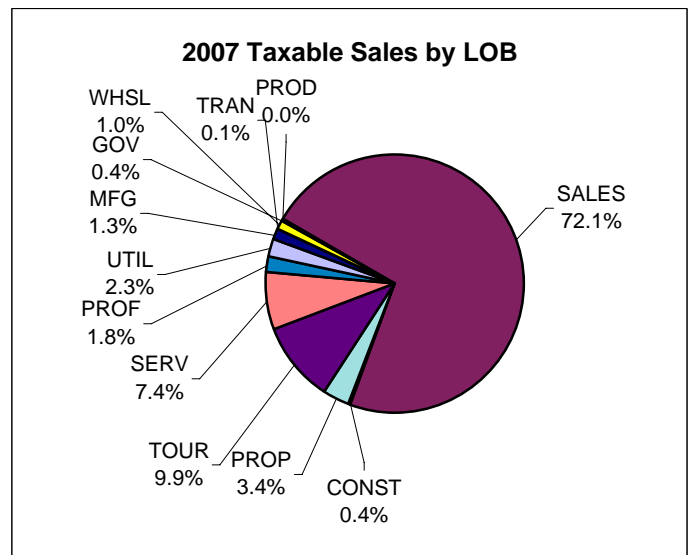

Chart 6.12

Soldotna TAXABLE Sales by Line of Business by Quarter - 2007 - in \$					
LOB	1st Quarter	2nd Quarter	3rd Quarter	4th Quarter	Total
Resource Production	1,838	17,491	18,088	5,716	43,133
Sales	31,845,883	42,044,799	59,266,959	42,499,615	175,657,256
Construction	198,072	241,760	264,300	281,056	985,188
Property	1,563,929	2,116,638	2,134,804	2,356,418	8,171,789
Tourism	4,316,624	6,247,463	9,078,308	4,399,684	24,042,079
Services	3,846,764	4,716,519	4,723,490	4,637,172	17,923,945
Professional	1,051,966	1,213,456	1,084,516	1,048,329	4,398,267
Utility	1,906,959	1,264,657	1,080,514	1,410,310	5,662,440
Manufacturing	423,409	757,253	1,679,741	253,947	3,114,350
Transportation & Warehousing	21,317	32,356	17,353	125,178	196,204
Wholesale	478,776	459,955	517,761	875,942	2,332,434
Government	226,083	294,789	227,333	219,931	968,136
TOTAL	45,881,620	59,407,136	80,093,167	58,113,298	243,495,221

Table 6.16

Soldotna Sales

Soldotna GROSS Sales by Line of Business by Quarter - 2006 - in \$					
LOB	1st Quarter	2nd Quarter	3rd Quarter	4th Quarter	Total
Resource Production	9,508	28,662	29,583	145,703	213,456
Sales	42,375,450	56,353,527	75,149,572	56,141,794	230,020,343
Construction	6,085,166	12,052,501	9,164,421	46,179,935	73,482,023
Property	3,784,079	4,408,627	4,931,224	5,277,792	18,401,722
Tourism	4,610,986	7,895,934	11,777,125	5,266,645	29,550,690
Services	4,688,676	6,130,248	6,586,677	6,068,471	23,474,072
Professional	3,267,962	2,648,600	2,517,005	7,668,527	16,102,094
Utility	3,012,535	2,118,707	1,852,957	3,043,343	10,027,542
Manufacturing	1,452,464	2,477,219	4,186,336	2,750,085	10,866,104
Transportation & Warehousing	774,795	1,279,552	1,168,980	917,536	4,140,863
Wholesale	2,145,245	3,350,490	3,466,478	6,494,786	15,456,999
Government	250,285	268,747	337,436	262,805	1,119,273
TOTAL	72,457,151	99,012,814	121,167,794	140,217,422	432,855,181

Table 6.17

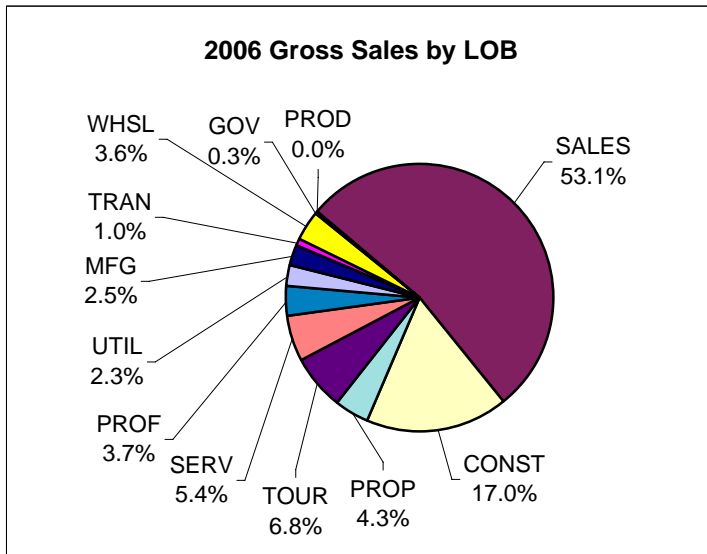

Chart 6.13

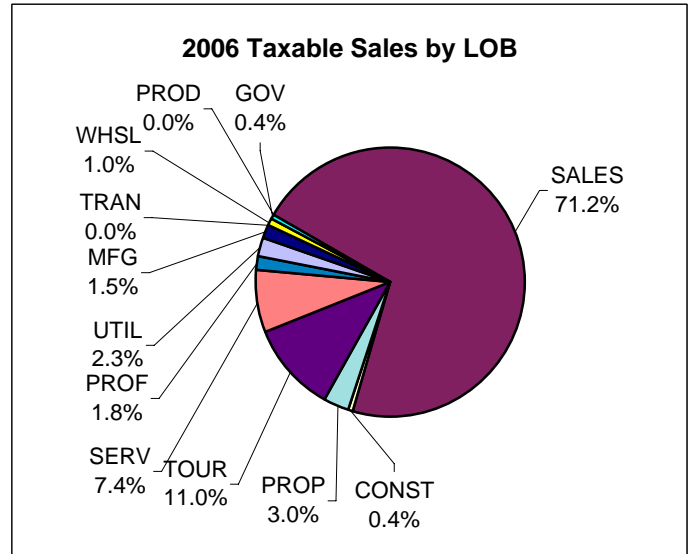

Chart 6.14

Soldotna TAXABLE Sales by Line of Business by Quarter - 2006 - in \$					
LOB	1st Quarter	2nd Quarter	3rd Quarter	4th Quarter	Total
Resource Production	1,990	14,023	12,868	5,446	34,327
Sales	28,494,919	38,817,334	55,303,929	39,439,020	162,055,202
Construction	209,813	253,076	228,897	247,023	938,809
Property	1,548,720	1,609,694	1,927,002	1,739,613	6,825,029
Tourism	4,303,975	6,787,726	9,232,083	4,742,818	25,066,602
Services	3,625,907	4,222,088	4,644,232	4,302,309	16,794,536
Professional	1,066,415	1,159,056	924,702	863,607	4,013,780
Utility	1,621,254	1,109,739	933,992	1,504,841	5,169,826
Manufacturing	527,827	714,499	1,520,449	643,127	3,405,902
Transportation & Warehousing	29,206	21,151	27,940	25,948	104,245
Wholesale	472,520	498,696	514,660	692,442	2,178,318
Government	215,019	231,090	286,966	225,376	958,451
TOTAL	42,117,565	55,438,172	75,557,720	54,431,570	227,545,027

Table 6.18

Soldotna Sales

Soldotna Annual Gross Sales by Quarter - in \$						
	1st Quarter	2nd Quarter	3rd Quarter	4th Quarter	Total	Annual Change
1995	40,627,047	53,363,505	64,724,383	54,057,905	212,772,840	
1996	44,155,649	54,086,799	66,745,597	53,262,403	218,250,448	2.6%
1997	43,136,587	56,048,000	71,982,003	61,417,298	232,583,888	6.6%
1998	46,245,330	61,860,448	76,091,735	66,596,151	250,793,664	7.8%
1999	51,429,980	67,872,794	87,697,762	70,577,461	277,577,997	10.7%
2000	55,201,896	72,515,215	89,530,301	72,007,899	289,255,311	4.2%
2001	60,802,277	75,042,511	95,670,432	77,603,011	309,118,231	6.9%
2002	62,331,750	79,762,672	103,625,416	80,180,782	325,900,620	5.4%
2003	64,254,952	85,227,616	106,268,314	82,155,118	337,906,000	3.7%
2004	69,929,668	89,310,129	107,196,637	94,822,445	361,258,879	6.9%
2005	65,958,153	87,630,570	113,939,869	128,504,871	396,033,463	9.6%
2006	72,457,151	99,012,814	121,167,794	140,217,422	432,855,181	9.3%
2007	79,259,451	102,966,180	130,199,945	116,869,811	429,295,387	-0.8%
2008	89,538,030	112,456,040	146,420,303	116,991,515	465,405,888	8.4%
Change	13.0%	9.2%	12.5%	0.1%	8.4%	

Table 6.19

Soldotna Annual Taxable Sales by Quarter - in \$						
	1st Quarter	2nd Quarter	3rd Quarter	4th Quarter	Total	Annual Change
1995	23,569,520	32,168,958	41,181,901	32,127,968	129,048,347	
1996	26,114,766	32,996,657	41,676,112	32,537,647	133,325,182	3.3%
1997	26,296,124	33,910,547	44,323,596	35,806,409	140,336,676	5.3%
1998	27,184,841	37,240,899	46,529,812	36,834,109	147,789,661	5.3%
1999	28,439,928	38,203,092	50,494,117	38,804,887	155,942,024	5.5%
2000	29,664,420	38,766,616	50,523,183	40,481,909	159,436,128	2.2%
2001	32,492,377	42,914,074	54,143,248	42,868,739	172,418,438	8.1%
2002	33,736,608	43,504,958	57,489,123	42,248,703	176,979,392	2.6%
2003	34,464,122	47,026,039	62,579,271	46,558,340	190,627,772	7.7%
2004	37,385,342	49,011,743	66,181,487	47,480,976	200,059,548	4.9%
2005	38,716,680	52,146,002	69,952,376	50,395,386	211,210,444	5.6%
2006	42,117,565	55,438,172	75,557,720	54,431,570	227,545,027	7.7%
2007	45,881,620	59,407,136	80,093,167	58,113,298	243,495,221	7.0%
2008	47,660,551	63,179,312	90,667,066	59,587,854	261,094,783	7.2%
Change	3.9%	6.3%	13.2%	2.5%	7.2%	

Table 6.20

Soldotna Annual Non-Taxable Sales by Quarter - in \$						
	1st Quarter	2nd Quarter	3rd Quarter	4th Quarter	Total	Annual Change
1995	17,057,527	21,194,547	23,542,482	21,929,937	83,724,493	
1996	18,040,883	21,090,142	25,069,485	20,724,756	84,925,266	1.4%
1997	16,840,463	22,137,453	27,658,407	25,610,889	92,247,212	8.6%
1998	19,060,489	24,619,549	29,561,923	29,762,042	103,004,003	11.7%
1999	22,990,052	29,669,702	37,203,645	31,772,574	121,635,973	18.1%
2000	25,537,476	33,748,599	39,007,118	31,525,990	129,819,183	6.7%
2001	28,309,900	32,128,437	41,527,184	34,734,272	136,699,793	5.3%
2002	28,595,142	36,257,714	46,136,293	37,932,079	148,921,228	8.9%
2003	29,790,830	38,201,577	43,689,043	35,596,778	147,278,228	-1.1%
2004	32,544,326	40,298,386	41,015,150	47,341,469	161,199,331	9.5%
2005	27,241,473	35,484,568	43,987,493	78,109,485	184,823,019	14.7%
2006	30,339,586	43,574,642	45,610,074	85,785,852	205,310,154	11.1%
2007	33,377,831	43,559,044	50,106,778	58,756,513	185,800,166	-9.5%
2008	41,877,479	49,276,728	55,753,237	57,403,661	204,311,105	10.0%
Change	25.5%	13.1%	11.3%	-2.3%	10.0%	

Table 6.21

Soldotna Construction Permits

Soldotna 4th Quarter Permit VALUES by Type - 2002-2008 - in \$

	2002	2003	2004	2005	2006	2007	2008	Annual Change
Residential New	176,000	526,191	294,860	165,123	172,833	88,000	8,000	-90.9%
Residential Alter/Add	11,500	5,000	57,454	2,000	262,659	248,665	5,000	-98.0%
Commercial New	0	281,491	501,601	0	0	1,654,112	176,146	-89.4%
Commercial Alter/Add	70,000	60,363	3,850,000	2,717	197,390	301,268	75,000	-75.1%
Total	257,500	873,045	4,703,915	169,840	632,882	2,292,045	264,146	-88.5%
Annual Change		239.0%	438.8%	-96.4%	272.6%	262.2%	-88.5%	

Table 6.22

Soldotna 4th Quarter Permit VALUES by Type - 1986-2008

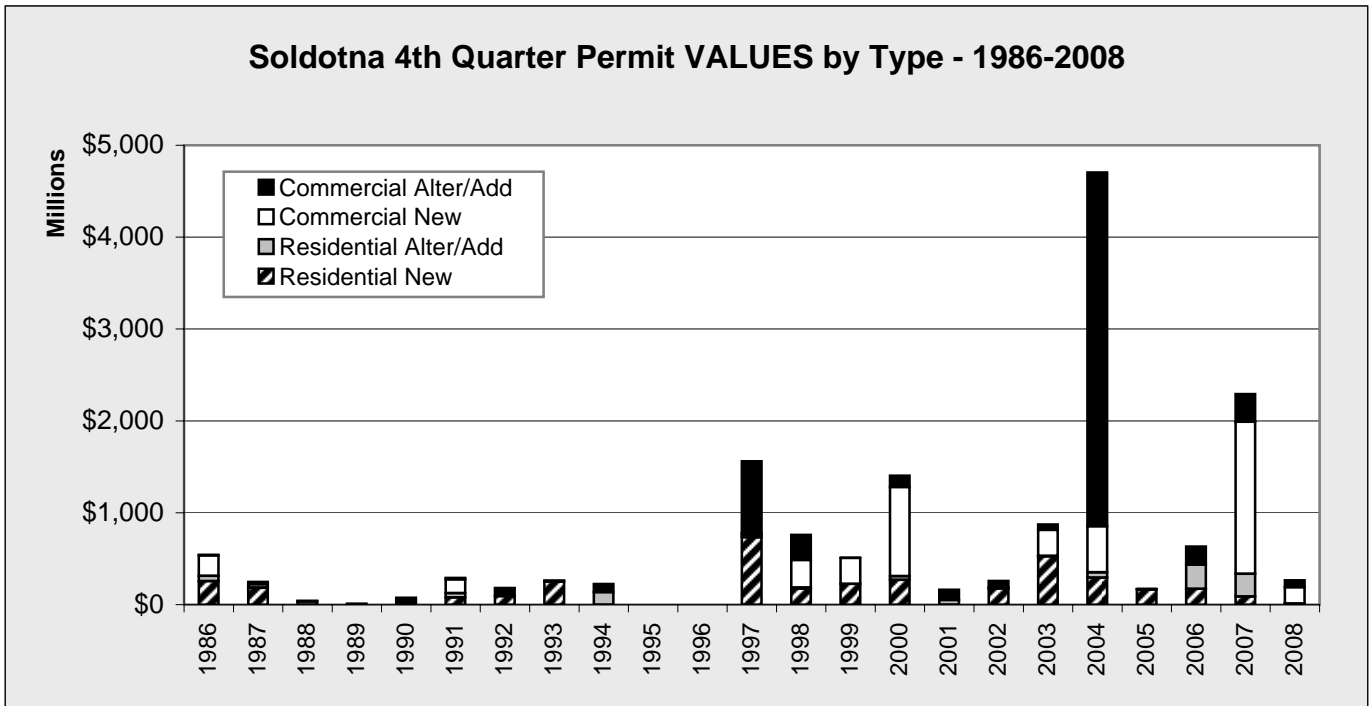

Chart 6.15

**Soldotna 4th Quarter Permit VALUES
Percent by Type - 2008**

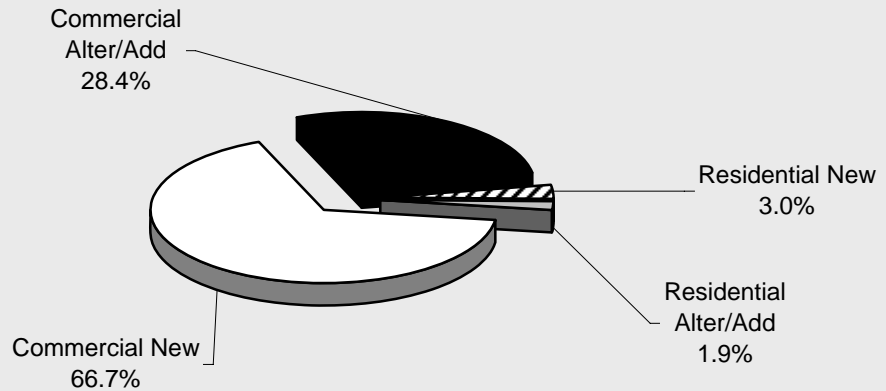

Chart 6.16

Soldotna Construction Permits

Soldotna 4th Quarter Permit VOLUME by Type - 2002-2008								
	2002	2003	2004	2005	2006	2007	2008	Annual Change
Residential New	1	5	1	1	1	2	1	-50.0%
Residential Alter/Add	2	1	3	1	3	6	1	-83.3%
Commercial New	0	2	2	0	0	4	1	-75.0%
Commercial Alter/Add	1	5	2	3	3	4	2	-50.0%
Total	4	13	8	5	7	16	5	-68.8%
Annual Change		225.0%	-38.5%	-37.5%	40.0%	128.6%	-68.8%	

Table 6.23

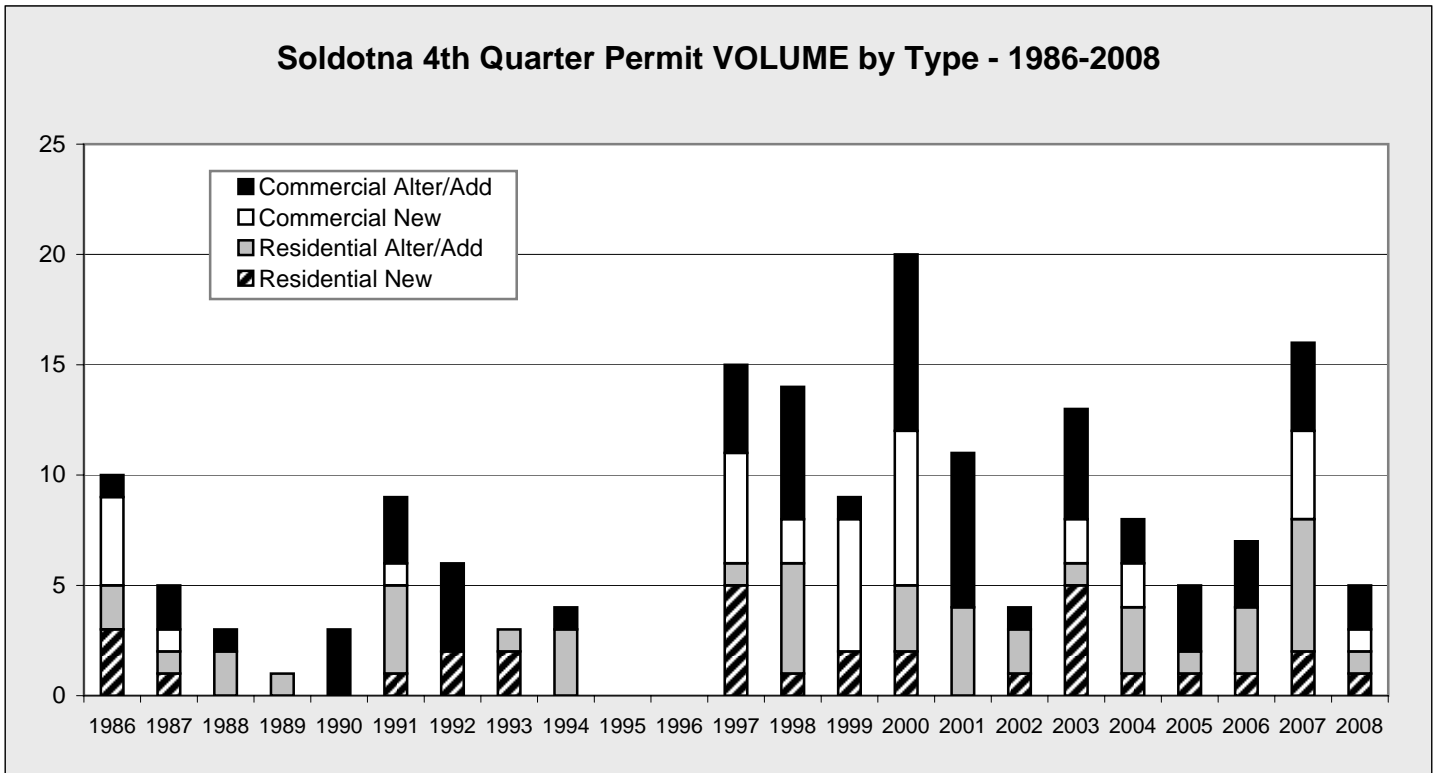

Chart 6.17

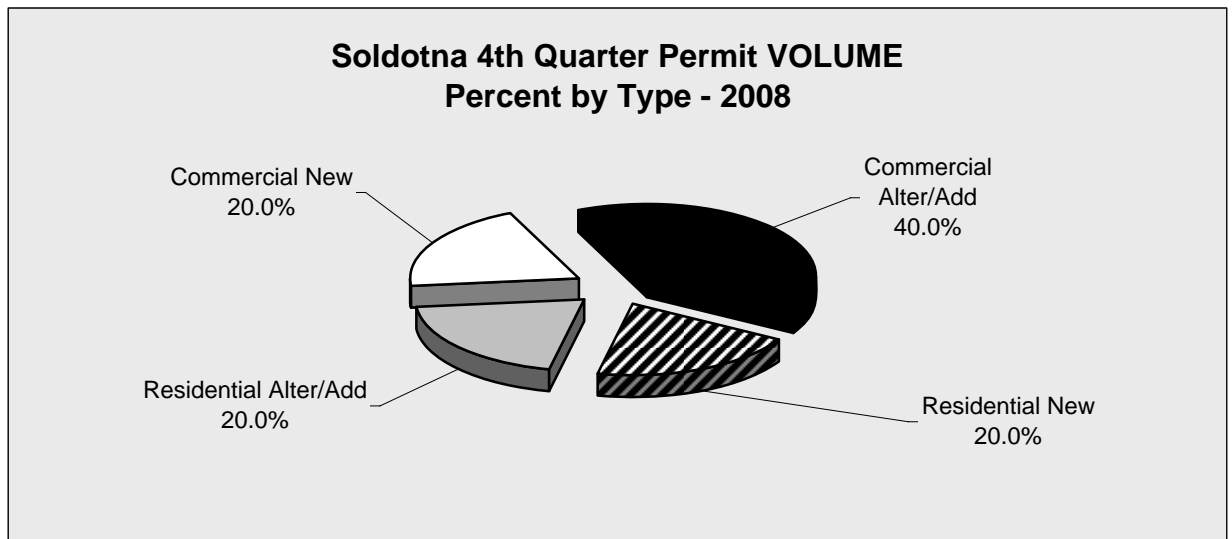

Chart 6.18

Soldotna Construction Permits

Soldotna Annual Permit VALUES by Type - 2002-2008 - in \$								
	2002	2003	2004	2005	2006	2007	2008	Annual Change
Residential New	3,181,344	3,073,933	3,881,344	4,098,748	7,599,440	8,749,413	4,325,763	-50.6%
Residential Alter/Add	755,187	263,629	277,984	493,990	782,177	733,440	659,809	-10.0%
Commercial New	4,397,059	3,769,181	28,329,025	5,814,828	12,924,852	3,661,554	13,119,066	258.3%
Commercial Alter/Add	2,830,304	845,554	4,808,573	1,101,794	1,887,931	618,516	1,388,543	124.5%
Total	11,163,894	7,952,297	37,296,926	11,509,360	23,194,400	13,762,923	19,493,181	41.6%
Annual Change		-28.8%	369.0%	-69.1%	101.5%	-40.7%	41.6%	

Table 6.24

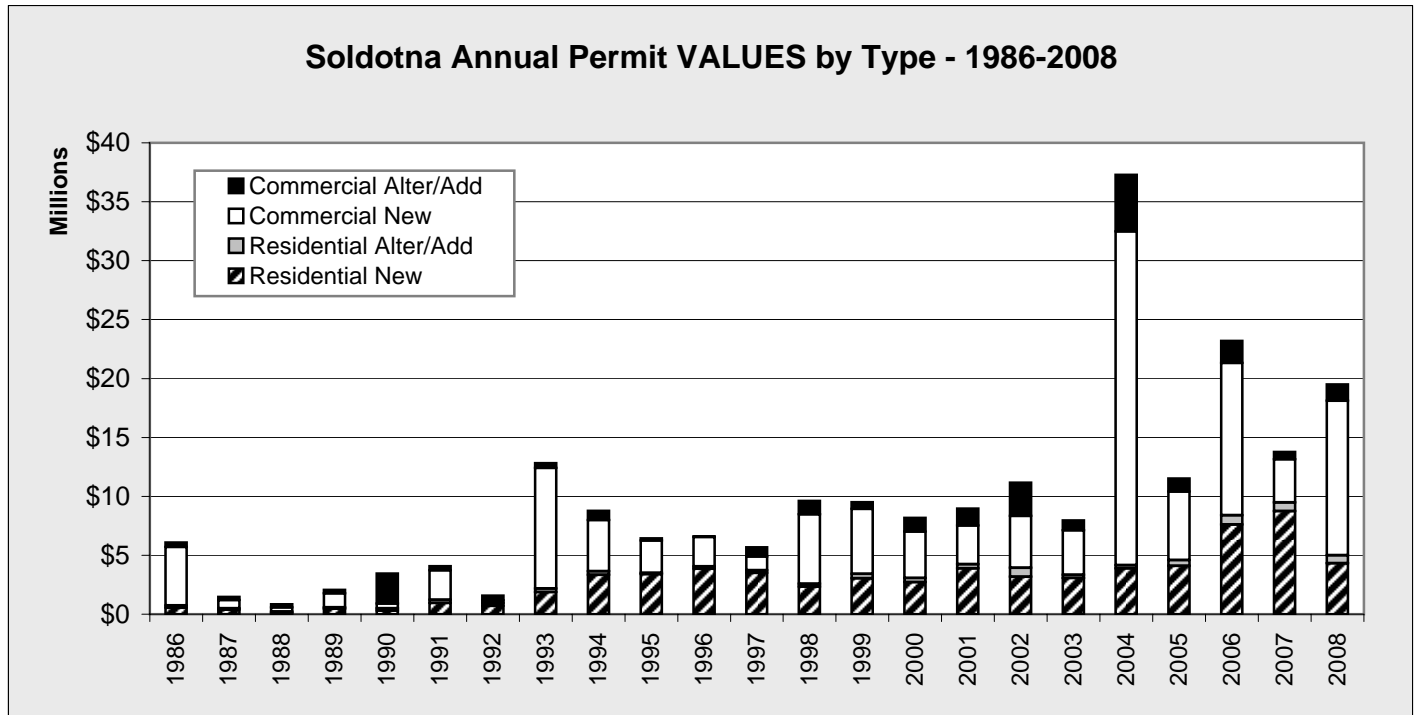

Chart 6.19

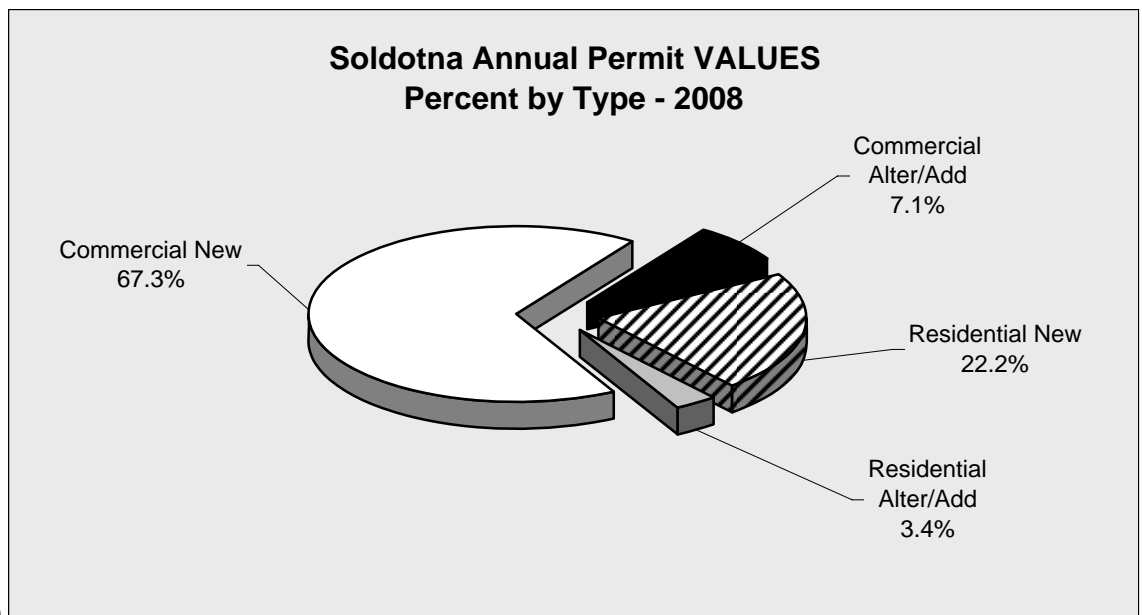

Chart 6.20

Soldotna Construction Permits

Soldotna Annual Permit VOLUME by Type - 2002-2008								
	2002	2003	2004	2005	2006	2007	2008	Annual Change
Residential New	24	24	19	23	29	30	25	-16.7%
Residential Alter/Add	20	16	17	23	15	18	26	44.4%
Commercial New	18	16	13	13	9	11	15	36.4%
Commercial Alter/Add	29	18	18	22	11	21	25	19.0%
Total	91	74	67	81	64	80	91	13.8%
Annual Change		-18.7%	-9.5%	20.9%	-21.0%	25.0%	13.8%	

Table 6.25

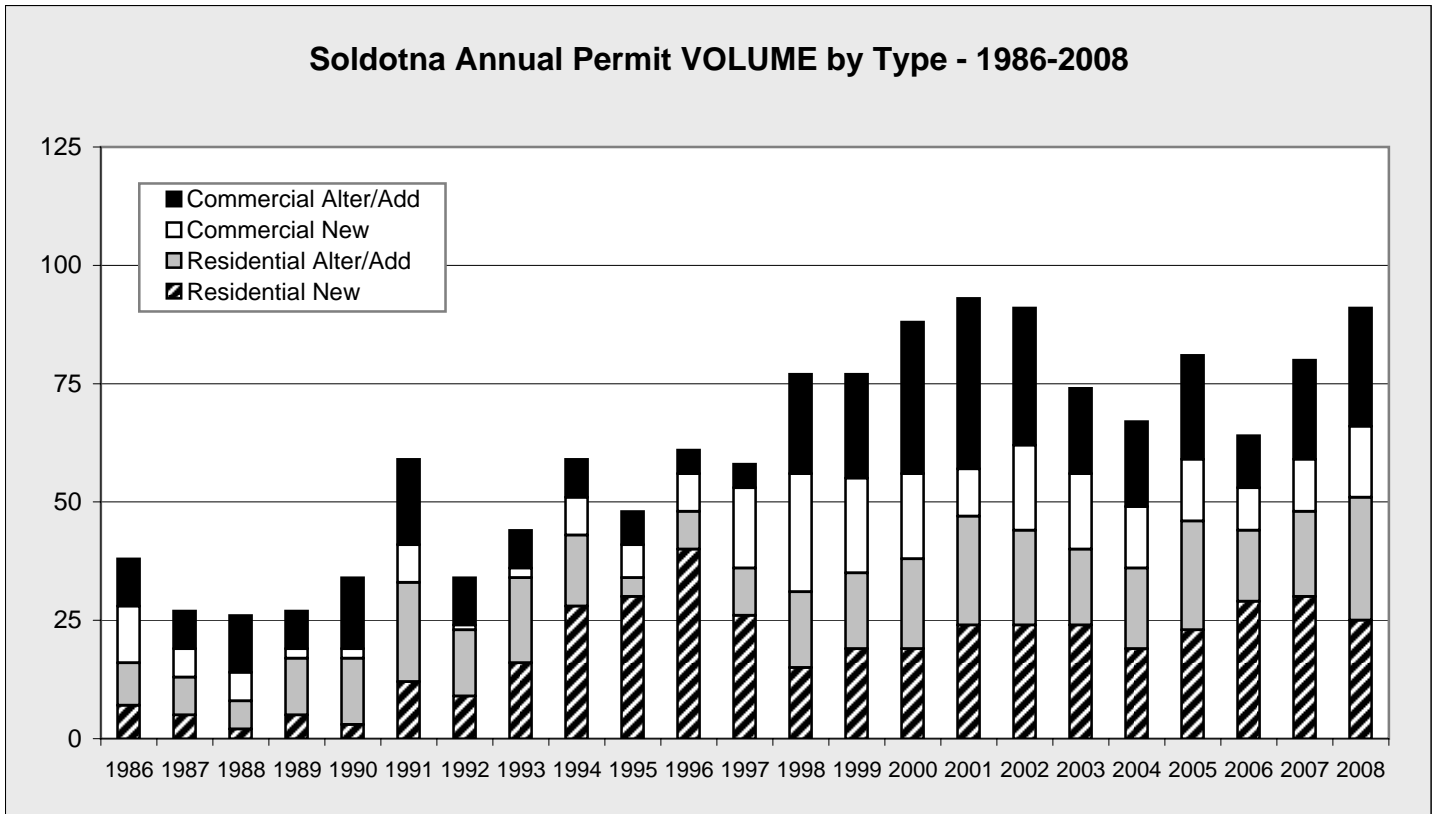

Chart 6.21

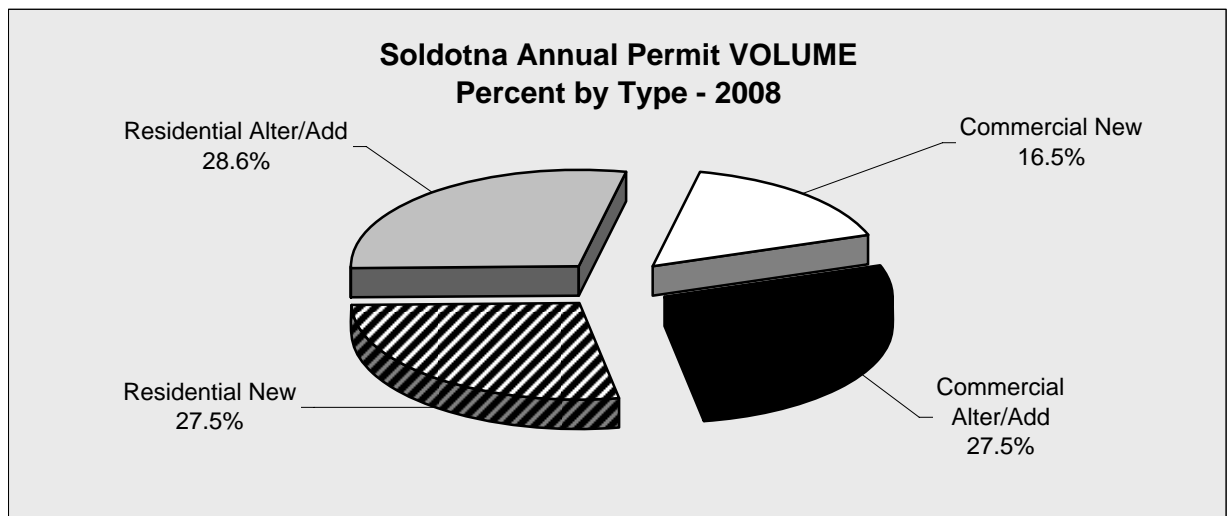

Chart 6.22

Soldotna Construction Permits

Soldotna Annual Permit VALUE by Type by Quarter - 2001-2008 - in \$					
	1st Quarter	2nd Quarter	3rd Quarter	4th Quarter	Total
2001					
Residential - New	0	2,363,001	1,510,852	0	3,873,853
Residential - Add/Alter	105,160	151,039	50,148	51,148	357,495
Commercial - New	2,658,578	0	630,244	0	3,288,822
Commercial - Add/Alter	287,480	717,150	318,672	111,500	1,434,802
TOTAL	3,051,218	3,231,190	2,509,916	162,648	8,954,972
2002					
Residential - New	240,849	2,075,293	689,202	176,000	3,181,344
Residential - Add/Alter	86,935	339,286	317,466	11,500	755,187
Commercial - New	714,806	2,601,575	1,080,678	0	4,397,059
Commercial - Add/Alter	163,000	1,987,304	610,000	70,000	2,830,304
TOTAL	1,205,590	7,003,458	2,697,346	257,500	11,163,894
2003					
Residential - New	0	1,899,354	648,388	526,191	3,073,933
Residential - Add/Alter	57,827	130,080	70,722	5,000	263,629
Commercial - New	0	2,116,490	1,371,200	281,491	3,769,181
Commercial - Add/Alter	369,191	88,000	328,000	60,363	845,554
TOTAL	427,018	4,233,924	2,418,310	873,045	7,952,297
2004					
Residential - New	539,297	1,777,087	1,270,100	294,860	3,881,344
Residential - Add/Alter	0	74,809	145,721	57,454	277,984
Commercial - New	4,465,026	1,366,297	21,996,101	501,601	28,329,025
Commercial - Add/Alter	60,000	530,380	368,193	3,850,000	4,808,573
TOTAL	5,064,323	3,748,573	23,780,115	4,703,915	37,296,926
2005					
Residential - New	720,956	1,916,999	1,295,670	165,123	4,098,748
Residential - Add/Alter	261,630	141,950	88,410	2,000	493,990
Commercial - New	195,000	4,099,828	1,520,000	0	5,814,828
Commercial - Add/Alter	243,969	673,458	181,650	2,717	1,101,794
TOTAL	1,421,555	6,832,235	3,085,730	169,840	11,509,360
2006					
Residential - New	204,031	2,116,499	5,106,077	172,833	7,599,440
Residential - Add/Alter	10,000	140,730	368,788	262,659	782,177
Commercial - New	312,410	4,965,648	7,646,794	0	12,924,852
Commercial - Add/Alter	1,590,000	8,451	92,090	197,390	1,887,931
TOTAL	2,116,441	7,231,328	13,213,749	632,882	23,194,400
2007					
Residential - New	535,722	6,083,538	2,042,153	88,000	8,749,413
Residential - Add/Alter	149,549	224,588	110,638	248,665	733,440
Commercial - New	0	1,461,142	546,300	1,654,112	3,661,554
Commercial - Add/Alter	142,500	107,937	66,811	301,268	618,516
TOTAL	827,771	7,877,205	2,765,902	2,292,045	13,762,923
2008					
Residential - New	447,277	3,273,346	597,140	8,000	4,325,763
Residential - Add/Alter	54,296	173,875	426,638	5,000	659,809
Commercial - New	1,464,737	832,900	10,645,283	176,146	13,119,066
Commercial - Add/Alter	339,943	932,000	41,600	75,000	1,388,543
TOTAL	2,306,253	5,212,121	11,710,661	264,146	19,493,181

Table 6.26

Soldotna Construction Permits

Soldotna Annual Permit VOLUME by Type by Quarter - 2001-2008					
	1st Quarter	2nd Quarter	3rd Quarter	4th Quarter	Total
2001					
Residential - New	0	14	10	0	24
Residential - Add/Alter	3	10	6	4	23
Commercial - New	3	0	7	0	10
Commercial - Add/Alter	4	13	12	7	36
TOTAL	10	37	35	11	93
2002					
Residential - New	1	17	5	1	24
Residential - Add/Alter	2	6	10	2	20
Commercial - New	4	9	5	0	18
Commercial - Add/Alter	4	19	5	1	29
TOTAL	11	51	25	4	91
2003					
Residential - New	0	15	4	5	24
Residential - Add/Alter	3	8	4	1	16
Commercial - New	0	6	8	2	16
Commercial - Add/Alter	3	7	3	5	18
TOTAL	6	36	19	13	74
2004					
Residential - New	2	9	7	1	19
Residential - Add/Alter	0	8	6	3	17
Commercial - New	4	3	4	2	13
Commercial - Add/Alter	3	6	7	2	18
TOTAL	9	26	24	8	67
2005					
Residential - New	4	11	7	1	23
Residential - Add/Alter	3	12	7	1	23
Commercial - New	2	9	2	0	13
Commercial - Add/Alter	7	8	4	3	22
TOTAL	16	40	20	5	81
2006					
Residential - New	1	13	14	1	29
Residential - Add/Alter	1	6	5	3	15
Commercial - New	1	5	3	0	9
Commercial - Add/Alter	2	1	5	3	11
TOTAL	5	25	27	7	64
2007					
Residential - New	2	16	10	2	30
Residential - Add/Alter	2	5	5	6	18
Commercial - New	0	5	2	4	11
Commercial - Add/Alter	5	7	5	4	21
TOTAL	9	33	22	16	80
2008					
Residential - New	3	19	2	1	25
Residential - Add/Alter	3	7	15	1	26
Commercial - New	5	3	6	1	15
Commercial - Add/Alter	10	8	5	2	25
TOTAL	21	37	28	5	91

Table 6.27

Other KPB Sales

Other KPB Fourth Quarter GROSS Sales by Line of Business - 2003-2008 - in \$								
LOB	2003	2004	2005	2006	2007	2008	Annual Percent Change	Annual Amount Change
PROD	55,199,174	50,502,635	45,773,451	32,377,396	51,832,661	58,517,767	12.9%	6,685,106
SALES	31,679,072	33,760,006	35,130,704	36,843,971	39,363,245	43,051,046	9.4%	3,687,801
CONST	28,711,977	52,594,160	44,695,276	62,322,648	49,805,844	40,948,878	-17.8%	-8,856,966
PROP	6,449,678	7,398,356	7,536,078	7,176,819	10,198,601	9,331,675	-8.5%	-866,926
TOUR	4,503,967	5,125,532	5,064,868	5,598,667	5,242,624	3,959,159	-24.5%	-1,283,465
SERV	11,029,002	24,581,626	18,057,851	19,160,532	22,797,887	29,031,330	27.3%	6,233,443
PROF	3,786,209	4,782,297	5,130,258	6,655,343	6,610,318	6,444,914	-2.5%	-165,404
UTIL	8,795,544	9,695,190	11,658,194	14,131,249	13,724,445	16,707,332	21.7%	2,982,887
MANU	25,020,618	25,676,505	31,183,970	21,938,406	8,333,407	28,724,769	244.7%	20,391,362
TRAN	4,187,475	7,854,607	8,940,544	8,774,423	6,021,352	8,996,532	49.4%	2,975,180
WHLS	35,184,438	203,905,853	234,921,588	263,634,332	295,052,191	336,622,470	14.1%	41,570,279
GOV	831,604	1,050,543	481,482	332,503	93,251	72,149	-22.6%	-21,102
TOTAL	215,378,758	426,927,310	448,574,264	478,946,289	509,075,826	582,408,021	14.4%	73,332,195

Table 7.1 For complete listing of Lines of Business, see page 13

Fourth Quarter GROSS Sales	
2003	215,378,758
2004	426,927,310
2005	448,574,264
2006	478,946,289
2007	509,075,826
2008	582,408,021

Table 7.2

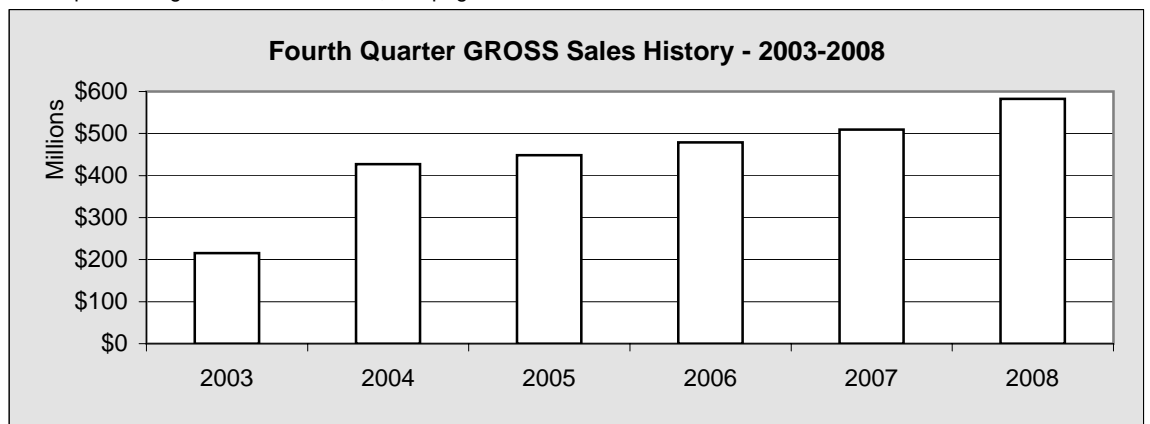

Chart 7.1

Five Year Change Fourth Quarter GROSS Sales		
	2003	2008
PROD	55,199,174	58,517,767
SALES	31,679,072	43,051,046
CONST	28,711,977	40,948,878
PROP	6,449,678	9,331,675
TOUR	4,503,967	3,959,159
SERV	11,029,002	29,031,330
PROF	3,786,209	6,444,914
UTIL	8,795,544	16,707,332
MANU	25,020,618	28,724,769
TRAN	4,187,475	8,996,532
WHLS	35,184,438	336,622,470
GOV	831,604	72,149
TOTAL	215,378,758	582,408,021

Table 7.3

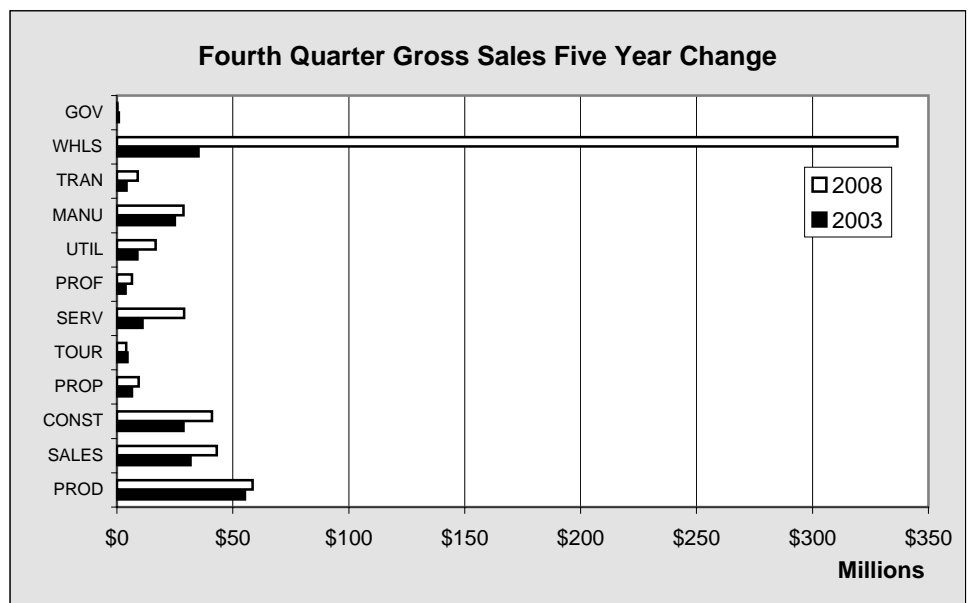

Chart 7.2

Other KPB Sales

Other KPB Fourth Quarter TAXABLE Sales by Line of Business - 2003-2008 - in \$

LOB	2003	2004	2005	2006	2007	2008	Annual Percent Change	Annual Amount Change
PROD	978,594	1,194,857	1,017,754	1,065,297	1,262,053	1,580,458	25.2%	318,405
SALES	16,116,634	15,063,091	15,831,783	16,881,665	18,095,709	20,507,787	13.3%	2,412,078
CONST	1,818,996	1,754,952	1,684,626	1,935,789	2,186,430	2,006,375	-8.2%	-180,055
PROP	2,149,517	2,224,711	2,407,781	2,678,530	2,825,829	3,025,480	7.1%	199,651
TOUR	3,943,177	4,017,454	4,205,017	4,534,785	4,473,486	3,092,473	-30.9%	-1,381,013
SERV	6,324,048	7,771,506	8,102,905	8,349,108	9,583,765	11,974,301	24.9%	2,390,536
PROF	964,463	1,037,860	1,161,660	1,223,788	1,398,597	1,294,260	-7.5%	-104,337
UTIL	5,770,580	6,249,975	7,137,578	9,142,420	8,820,971	10,758,298	22.0%	1,937,327
MANU	463,805	546,775	588,708	601,350	786,465	610,022	-22.4%	-176,443
TRAN	173,088	178,987	234,263	224,748	250,307	228,232	-8.8%	-22,075
WHLS	4,299,606	5,437,244	6,390,100	7,286,491	8,147,426	8,052,829	-1.2%	-94,597
GOV	39,501	18,063	10,330	7,500	5,790	13,660	135.9%	7,870
TOTAL	43,042,009	45,495,475	48,772,505	53,931,471	57,836,828	63,144,175	9.2%	5,307,347

Table 7.4

For complete listing of Lines of Business, see page 13

Fourth Quarter TAXABLE Sales	
2003	43,042,009
2004	45,495,475
2005	48,772,505
2006	53,931,471
2007	57,836,828
2008	63,144,175

Table 7.5

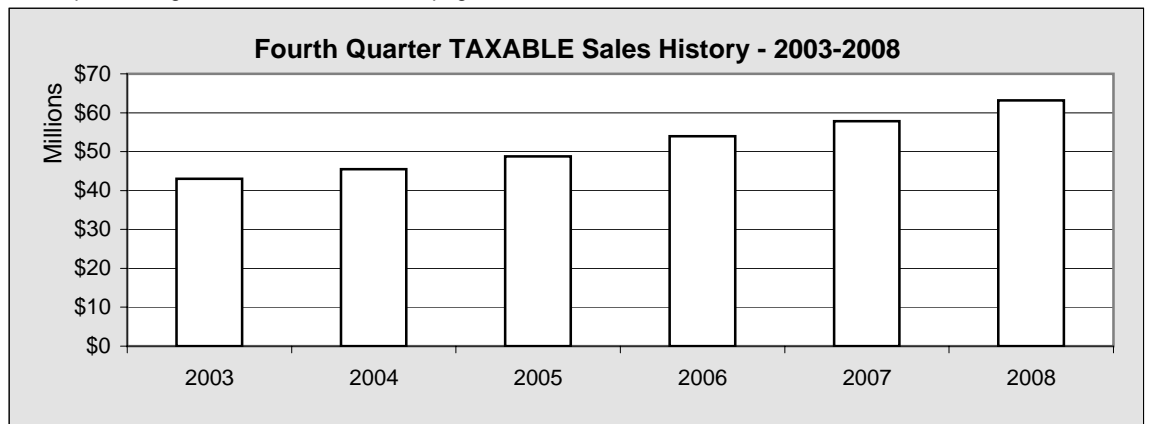

Chart 7.3

Five Year Change Fourth Quarter TAXABLE Sales		
	2003	2008
PROD	978,594	1,580,458
SALES	16,116,634	20,507,787
CONST	1,818,996	2,006,375
PROP	2,149,517	3,025,480
TOUR	3,943,177	3,092,473
SERV	6,324,048	11,974,301
PROF	964,463	1,294,260
UTIL	5,770,580	10,758,298
MANU	463,805	610,022
TRAN	173,088	228,232
WHLS	4,299,606	8,052,829
GOV	39,501	13,660
TOTAL	43,042,009	63,144,175

Table 7.6

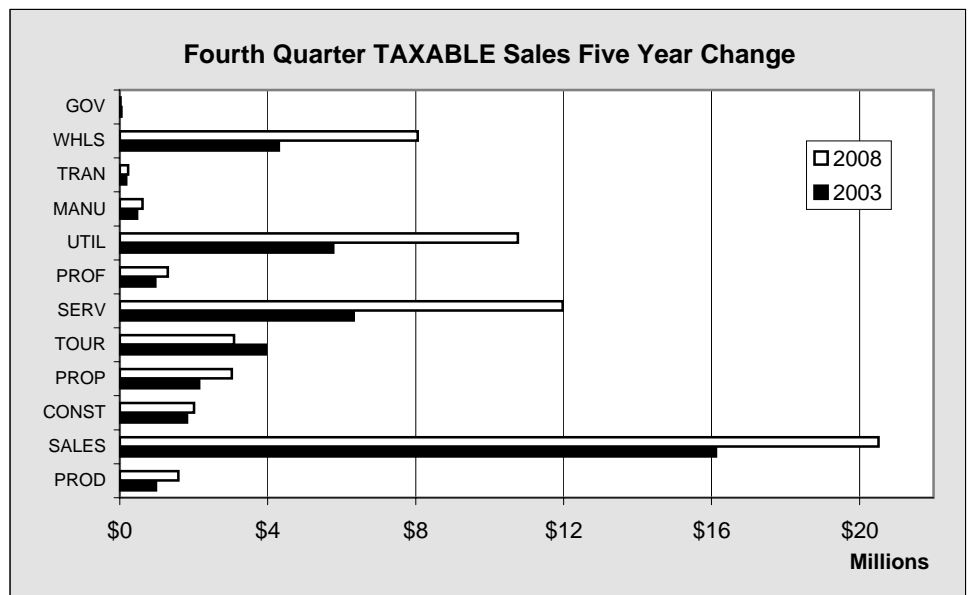

Chart 7.4

Other KPB Sales

Other KPB Annual GROSS Sales by Line of Business - 2003-2008 - in \$								
LOB	2003	2004	2005	2006	2007	2008	Annual Percent Change	Annual Amount Change
PROD	174,128,291	147,140,780	153,182,362	175,123,026	148,522,424	159,516,682	7.4%	10,994,258
SALES	182,478,029	143,382,467	149,803,836	156,580,806	167,378,000	186,671,626	11.5%	19,293,626
CONST	123,133,969	121,240,100	126,832,067	154,241,220	166,892,716	149,383,384	-10.5%	-17,509,332
PROP	24,513,440	24,867,031	26,574,731	29,109,553	34,102,197	34,417,613	0.9%	315,416
TOUR	58,915,736	66,630,028	69,825,987	74,506,229	78,138,957	69,275,667	-11.3%	-8,863,290
SERV	44,239,266	63,181,724	63,766,927	70,084,535	85,664,928	114,481,526	33.6%	28,816,598
PROF	15,800,255	17,160,184	17,007,030	21,149,978	23,394,233	27,438,146	17.3%	4,043,913
UTIL	33,607,375	36,341,683	43,002,998	49,256,836	55,585,131	57,647,745	3.7%	2,062,614
MANU	85,828,471	131,419,015	187,397,786	121,518,657	126,541,825	189,882,175	50.1%	63,340,350
TRAN	16,628,065	35,308,579	36,122,095	37,924,615	26,049,567	32,818,314	26.0%	6,768,747
WHLS	102,174,522	315,068,865	330,371,937	359,368,992	385,468,249	458,484,194	18.9%	73,015,945
GOV	831,604	1,063,212	820,042	512,629	139,082	537,738	286.6%	398,656
TOTAL	862,279,023	1,102,803,668	1,204,707,798	1,249,377,076	1,297,877,309	1,480,554,810	14.1%	182,677,501

Table 7.7

For complete listing of Lines of Business, see page 13

Annual GROSS Sales History	
2003	862,279,023
2004	1,102,803,668
2005	1,204,707,798
2006	1,249,377,076
2007	1,297,877,309
2008	1,480,554,810

Table 7.8

Chart 7.5

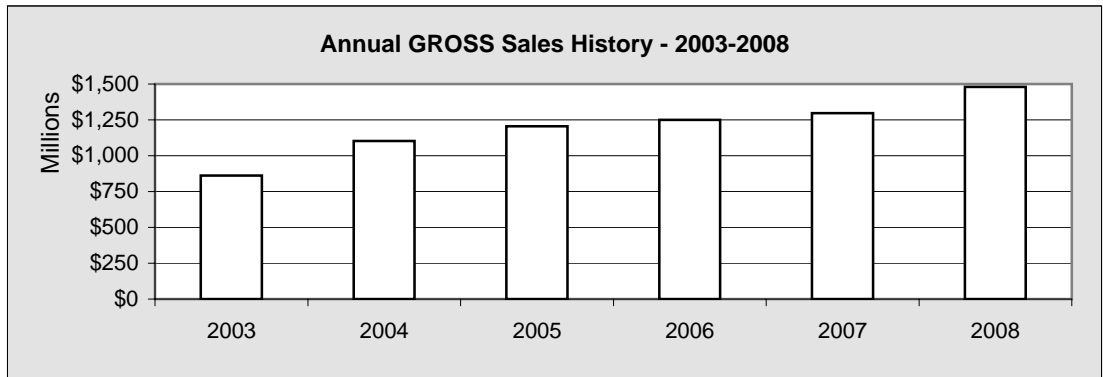

Five Year Change Annual GROSS Sales		
	2003	2008
PROD	174,128,291	159,516,682
SALES	182,478,029	186,671,626
CONST	123,133,969	149,383,384
PROP	24,513,440	34,417,613
TOUR	58,915,736	69,275,667
SERV	44,239,266	114,481,526
PROF	15,800,255	27,438,146
UTIL	33,607,375	57,647,745
MANU	85,828,471	189,882,175
TRAN	16,628,065	32,818,314
WHLS	102,174,522	458,484,194
GOV	831,604	537,738
TOTAL	862,279,023	1,480,554,810

Table 7.9

Chart 7.6

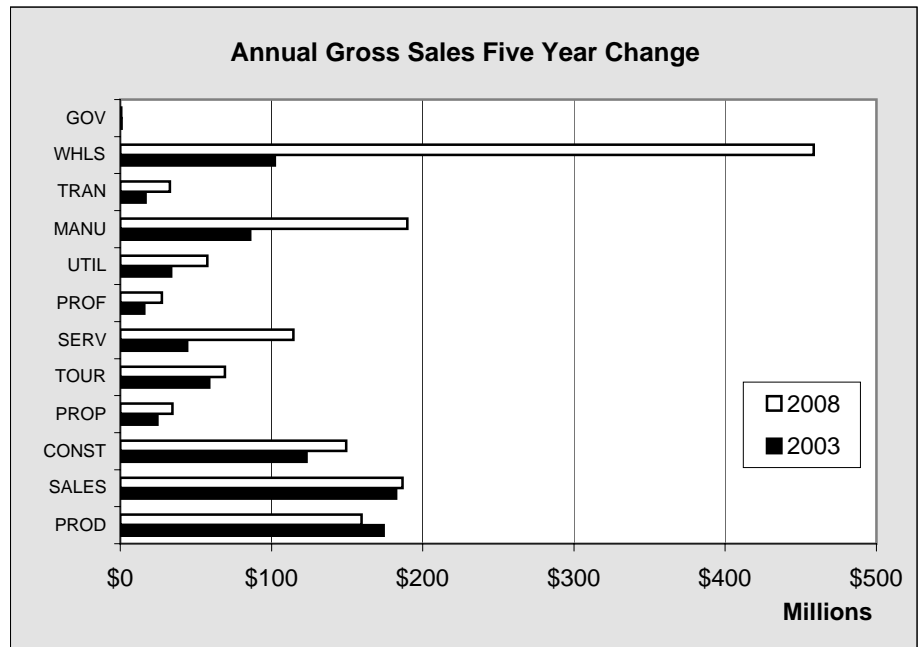

Other KPB Sales

Other KPB Annual TAXABLE Sales by Line of Business - 2003-2008 - in \$								
LOB	2003	2004	2005	2006	2007	2008	Annual Percent Change	Annual Amount Change
PROD	5,001,743	5,331,875	4,502,307	4,628,764	5,244,276	6,011,202	14.6%	766,926
SALES	72,262,286	68,560,411	69,150,050	75,416,814	80,153,012	94,935,337	18.4%	14,782,325
CONST	7,519,106	7,202,164	6,783,831	7,378,366	8,168,541	8,194,860	0.3%	26,319
PROP	9,331,726	9,312,213	9,995,154	11,243,745	12,556,206	13,240,502	5.4%	684,296
TOUR	44,178,366	49,103,371	51,654,969	54,875,324	66,029,697	58,673,244	-11.1%	-7,356,453
SERV	25,563,989	28,861,016	32,872,996	34,605,111	38,082,365	46,716,874	22.7%	8,634,509
PROF	4,218,877	4,399,051	4,637,341	5,106,239	5,705,529	5,517,029	-3.3%	-188,500
UTIL	22,028,897	22,822,064	26,157,508	31,333,082	34,536,924	36,976,492	7.1%	2,439,568
MANU	2,583,840	2,625,421	3,277,627	3,224,883	3,693,017	3,545,266	-4.0%	-147,751
TRAN	1,520,266	750,682	930,506	1,034,665	936,846	1,001,155	6.9%	64,309
WHLS	15,475,129	19,787,056	22,775,440	26,747,293	28,410,764	31,982,913	12.6%	3,572,149
GOV	39,501	30,667	50,936	15,303	26,808	53,750	100.5%	26,942
TOTAL	209,723,726	218,785,991	232,788,665	255,609,589	283,543,985	306,848,624	8.2%	23,304,639

Table 7.10

For complete listing of Lines of Business, see page 13

Annual TAXABLE Sales History	
2003	209,723,726
2004	218,785,991
2005	232,788,665
2006	255,609,589
2007	283,543,985
2008	306,848,624

Table 7.11

Chart 7.7

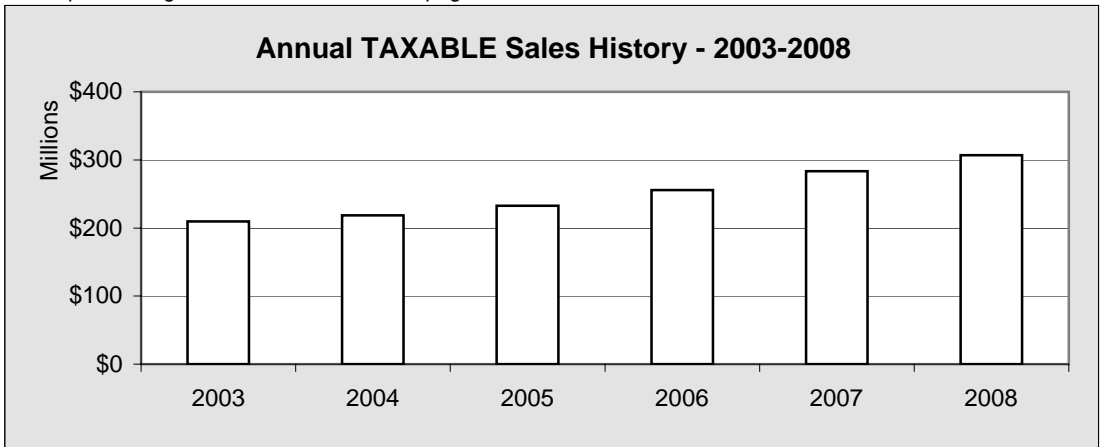

Five Year Change Annual TAXABLE Sales		
	2003	2008
PROD	5,001,743	6,011,202
SALES	72,262,286	94,935,337
CONST	7,519,106	8,194,860
PROP	9,331,726	13,240,502
TOUR	44,178,366	58,673,244
SERV	25,563,989	46,716,874
PROF	4,218,877	5,517,029
UTIL	22,028,897	36,976,492
MANU	2,583,840	3,545,266
TRAN	1,520,266	1,001,155
WHLS	15,475,129	31,982,913
GOV	39,501	53,750
TOTAL	209,723,726	306,848,624

Table 7.12

Chart 7.8

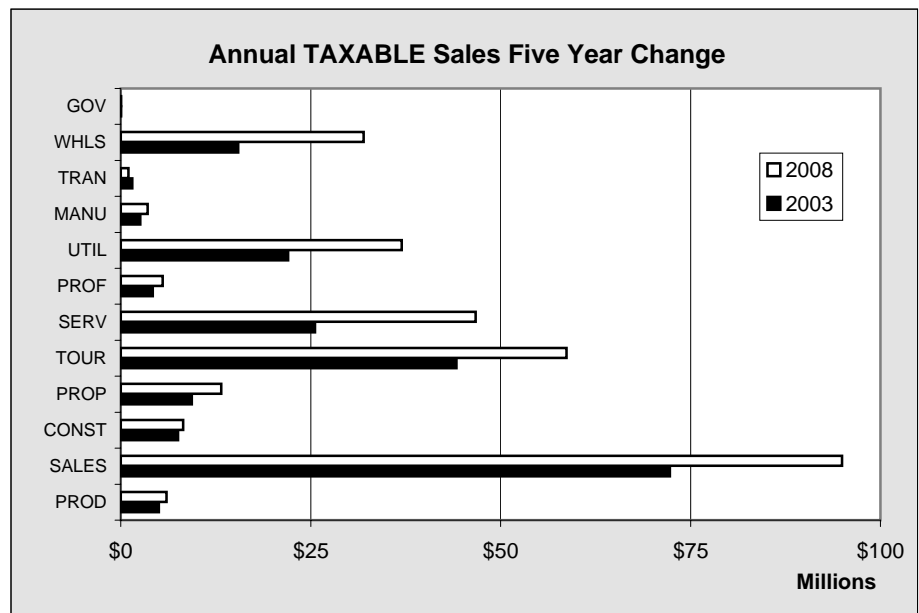

Other KPB Sales

Other KPB GROSS Sales by Line of Business by Quarter - 2008 - in \$					
LOB	1st Quarter	2nd Quarter	3rd Quarter	4th Quarter	Total
Resource Production	22,133,605	33,080,374	45,784,936	58,517,767	159,516,682
Sales	32,556,411	51,980,833	59,083,336	43,051,046	186,671,626
Construction	25,278,709	31,838,817	51,316,980	40,948,878	149,383,384
Property	5,550,990	8,408,459	11,126,489	9,331,675	34,417,613
Tourism	2,945,041	21,073,270	41,298,197	3,959,159	69,275,667
Services	22,393,415	29,435,249	33,621,532	29,031,330	114,481,526
Professional	5,180,824	7,835,377	7,977,031	6,444,914	27,438,146
Utility	15,739,528	12,833,201	12,367,684	16,707,332	57,647,745
Manufacturing	27,926,865	64,537,243	68,693,298	28,724,769	189,882,175
Transportation & Warehousing	5,093,222	8,126,006	10,602,554	8,996,532	32,818,314
Wholesale	32,500,366	40,939,315	48,422,043	336,622,470	458,484,194
Government	303,976	16,321	145,292	72,149	537,738
TOTAL	197,602,952	310,104,465	390,439,372	582,408,021	1,480,554,810

Table 7.13

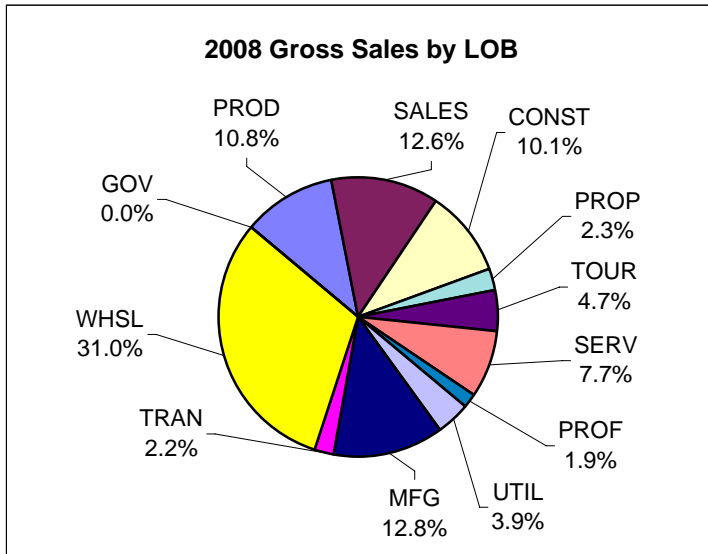

Chart 7.9

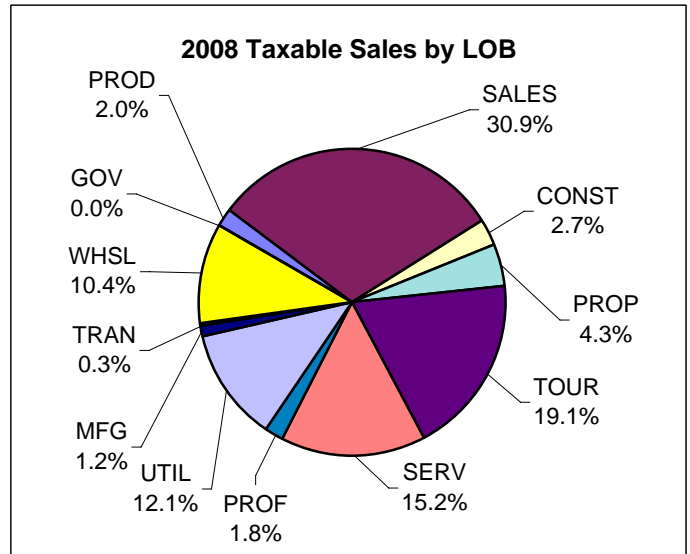

Chart 7.10

Other KPB TAXABLE Sales by Line of Business by Quarter - 2008 - in \$					
LOB	1st Quarter	2nd Quarter	3rd Quarter	4th Quarter	Total
Resource Production	912,669	1,939,300	1,578,775	1,580,458	6,011,202
Sales	15,978,538	26,163,244	32,285,768	20,507,787	94,935,337
Construction	1,495,920	1,999,973	2,692,592	2,006,375	8,194,860
Property	2,447,819	3,474,005	4,293,198	3,025,480	13,240,502
Tourism	2,636,558	18,479,839	34,464,374	3,092,473	58,673,244
Services	9,616,542	11,747,596	13,378,435	11,974,301	46,716,874
Professional	1,136,067	1,444,504	1,642,198	1,294,260	5,517,029
Utility	10,713,306	8,221,322	7,283,566	10,758,298	36,976,492
Manufacturing	407,765	940,643	1,586,836	610,022	3,545,266
Transportation & Warehousing	172,168	269,454	331,301	228,232	1,001,155
Wholesale	7,751,412	7,678,214	8,500,458	8,052,829	31,982,913
Government	15,266	8,551	16,273	13,660	53,750
TOTAL	53,284,030	82,366,645	108,053,774	63,144,175	306,848,624

Table 7.14

Other KPB Sales

Other KPB GROSS Sales by Line of Business by Quarter - 2007 - in \$					
LOB	1st Quarter	2nd Quarter	3rd Quarter	4th Quarter	Total
Resource Production	24,020,876	33,722,566	38,946,321	51,832,661	148,522,424
Sales	31,083,771	46,992,667	49,938,317	39,363,245	167,378,000
Construction	24,864,188	37,494,171	54,728,513	49,805,844	166,892,716
Property	6,001,714	8,171,623	9,730,259	10,198,601	34,102,197
Tourism	5,503,621	21,990,753	45,401,959	5,242,624	78,138,957
Services	17,094,489	21,589,435	24,183,117	22,797,887	85,664,928
Professional	4,900,707	5,367,801	6,515,407	6,610,318	23,394,233
Utility	16,970,630	12,163,388	12,726,668	13,724,445	55,585,131
Manufacturing	36,584,755	29,712,912	51,910,751	8,333,407	126,541,825
Transportation & Warehousing	4,658,253	6,698,060	8,671,902	6,021,352	26,049,567
Wholesale	25,345,813	29,204,686	35,865,559	295,052,191	385,468,249
Government	25,127	7,764	12,940	93,251	139,082
TOTAL	197,053,944	253,115,826	338,631,713	509,075,826	1,297,877,309

Table 7.15

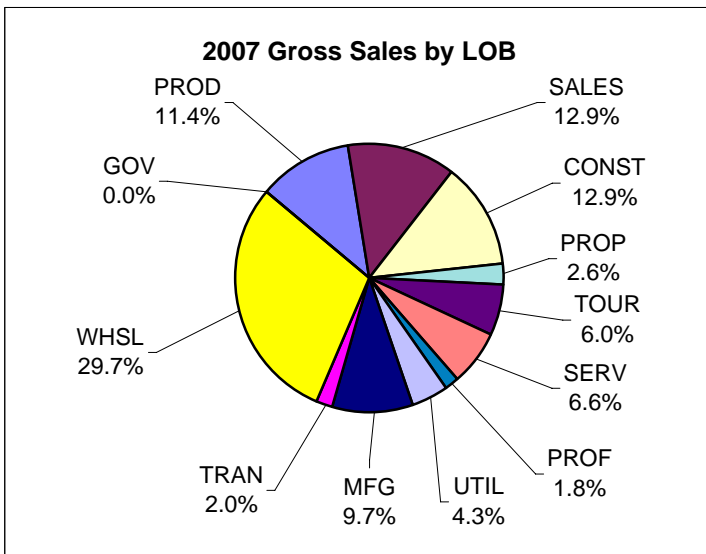

Chart 7.11

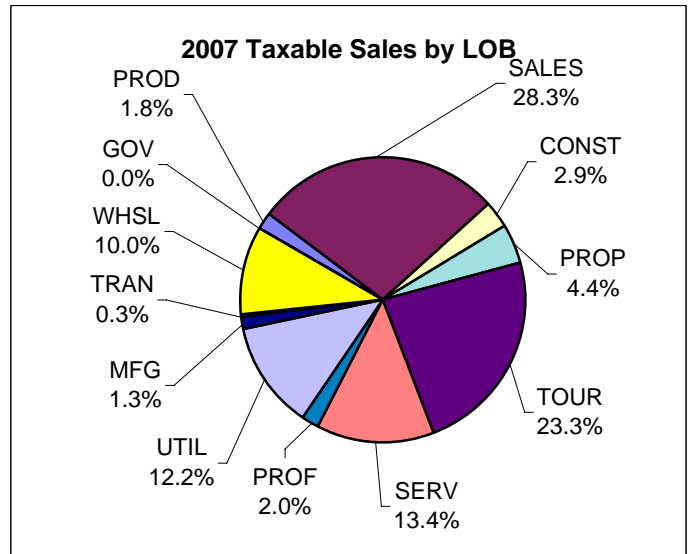

Chart 7.12

Other KPB TAXABLE Sales by Line of Business by Quarter - 2007 - in \$					
LOB	1st Quarter	2nd Quarter	3rd Quarter	4th Quarter	Total
Resource Production	831,139	1,764,037	1,387,047	1,262,053	5,244,276
Sales	13,703,348	22,280,866	26,073,089	18,095,709	80,153,012
Construction	1,380,642	2,023,788	2,577,681	2,186,430	8,168,541
Property	2,287,467	3,230,635	4,212,275	2,825,829	12,556,206
Tourism	3,937,072	19,442,729	38,176,410	4,473,486	66,029,697
Services	7,646,756	9,823,932	11,027,912	9,583,765	38,082,365
Professional	1,262,078	1,472,696	1,572,158	1,398,597	5,705,529
Utility	11,366,562	7,552,563	6,796,828	8,820,971	34,536,924
Manufacturing	405,938	1,036,940	1,463,674	786,465	3,693,017
Transportation & Warehousing	155,418	206,472	324,649	250,307	936,846
Wholesale	7,055,149	6,331,399	6,876,790	8,147,426	28,410,764
Government	12,918	3,500	4,600	5,790	26,808
TOTAL	50,044,487	75,169,557	100,493,113	57,836,828	283,543,985

Table 7.16

Other KPB Sales

Other KPB GROSS Sales by Line of Business by Quarter - 2006 - in \$					
LOB	1st Quarter	2nd Quarter	3rd Quarter	4th Quarter	Total
Resource Production	40,136,212	41,957,147	60,652,271	32,377,396	175,123,026
Sales	26,508,008	45,135,003	48,093,824	36,843,971	156,580,806
Construction	17,817,358	27,340,871	46,760,343	62,322,648	154,241,220
Property	5,259,580	7,716,904	8,956,250	7,176,819	29,109,553
Tourism	4,306,310	21,514,681	43,086,571	5,598,667	74,506,229
Services	14,306,132	17,396,627	19,221,244	19,160,532	70,084,535
Professional	4,316,631	4,661,169	5,516,835	6,655,343	21,149,978
Utility	14,204,879	10,777,719	10,142,989	14,131,249	49,256,836
Manufacturing	14,106,987	41,631,528	43,841,736	21,938,406	121,518,657
Transportation & Warehousing	6,124,411	11,159,723	11,866,058	8,774,423	37,924,615
Wholesale	25,363,123	32,318,210	38,053,327	263,634,332	359,368,992
Government	116,915	30,523	32,688	332,503	512,629
TOTAL	172,566,546	261,640,105	336,224,136	478,946,289	1,249,377,076

Table 7.17

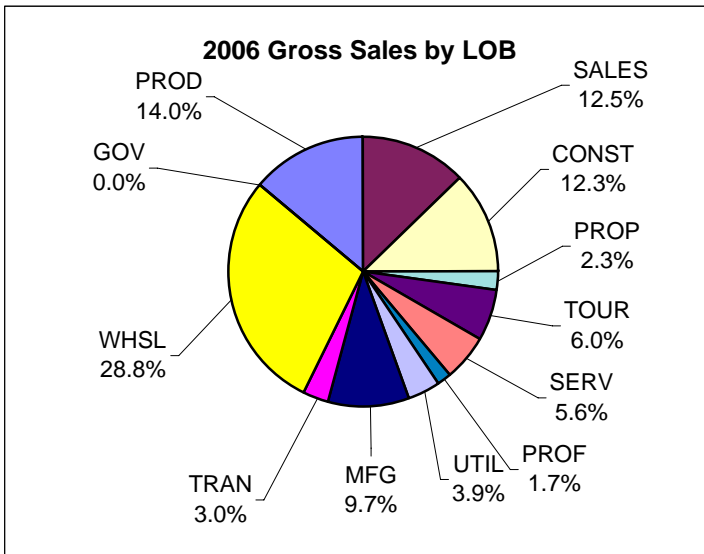

Chart 7.13

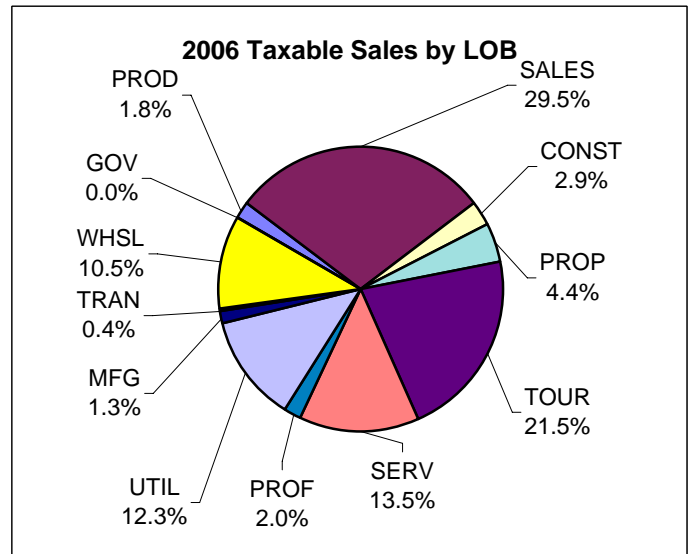

Chart 7.14

Other KPB TAXABLE Sales by Line of Business by Quarter - 2006 - in \$					
LOB	1st Quarter	2nd Quarter	3rd Quarter	4th Quarter	Total
Resource Production	802,513	1,578,756	1,182,198	1,065,297	4,628,764
Sales	13,259,849	21,001,208	24,274,092	16,881,665	75,416,814
Construction	1,206,598	1,949,022	2,286,957	1,935,789	7,378,366
Property	2,086,901	2,860,373	3,617,941	2,678,530	11,243,745
Tourism	3,860,547	16,514,092	29,965,900	4,534,785	54,875,324
Services	7,172,380	9,020,442	10,063,181	8,349,108	34,605,111
Professional	1,210,386	1,372,049	1,300,016	1,223,788	5,106,239
Utility	9,589,952	6,739,938	5,860,772	9,142,420	31,333,082
Manufacturing	383,815	864,966	1,374,752	601,350	3,224,883
Transportation & Warehousing	167,308	319,294	323,315	224,748	1,034,665
Wholesale	6,219,778	6,165,135	7,075,889	7,286,491	26,747,293
Government	1,500	3,279	3,024	7,500	15,303
TOTAL	45,961,527	68,388,554	87,328,037	53,931,471	255,609,589

Table 7.18

Other KPB Sales

Other KPB Annual Gross Sales by Quarter - in \$						
	1st Quarter	2nd Quarter	3rd Quarter	4th Quarter	Total	Annual Change
1995	129,319,512	176,942,172	232,992,009	155,265,007	694,518,700	
1996	118,786,765	164,578,524	200,339,231	146,554,575	630,259,095	-9.3%
1997	121,205,814	175,801,297	252,318,601	180,020,471	729,346,183	15.7%
1998	153,607,622	211,191,964	235,128,992	193,091,815	793,020,393	8.7%
1999	137,467,460	180,730,033	232,742,495	182,290,390	733,230,378	-7.5%
2000	126,664,981	183,977,517	225,474,396	172,187,791	708,304,685	-3.4%
2001	170,550,210	217,647,967	286,402,452	290,090,088	964,690,717	36.2%
2002	159,548,666	216,025,032	262,921,008	224,634,715	863,129,421	-10.5%
2003	154,468,221	208,425,856	284,006,188	215,378,758	862,279,023	-0.1%
2004	159,173,241	188,780,789	327,922,328	426,927,310	1,102,803,668	27.9%
2005	184,979,440	243,131,973	328,022,121	448,574,264	1,204,707,798	9.2%
2006	172,566,546	261,640,105	336,224,136	478,946,289	1,249,377,076	3.7%
2007	197,053,944	253,115,826	338,631,713	509,075,826	1,297,877,309	3.9%
2008	197,602,952	310,104,465	390,439,372	582,408,021	1,480,554,810	14.1%
Change	0.3%	22.5%	15.3%	14.4%	14.1%	

Table 7.19

Other KPB Annual Taxable Sales by Quarter - in \$						
	1st Quarter	2nd Quarter	3rd Quarter	4th Quarter	Total	Annual Change
1995	29,644,424	44,645,720	52,741,544	35,750,019	162,781,707	
1996	30,771,780	44,983,027	53,390,165	35,276,802	164,421,774	1.0%
1997	31,351,194	47,363,481	56,193,073	37,525,660	172,433,408	4.9%
1998	33,492,756	49,242,778	58,040,464	38,773,336	179,549,334	4.1%
1999	34,368,956	50,767,013	61,333,821	41,006,238	187,476,028	4.4%
2000	35,696,361	55,205,057	66,472,925	41,967,937	199,342,280	6.3%
2001	38,055,259	57,871,082	68,871,018	46,773,634	211,570,993	6.1%
2002	41,860,984	57,515,479	69,125,012	42,247,807	210,749,282	-0.4%
2003	38,386,873	58,301,294	69,993,550	43,042,009	209,723,726	-0.5%
2004	39,079,687	58,517,472	75,693,357	45,495,475	218,785,991	4.3%
2005	41,198,163	63,286,728	79,531,269	48,772,505	232,788,665	6.4%
2006	45,961,527	68,388,554	87,328,037	53,931,471	255,609,589	9.8%
2007	50,044,487	75,169,557	100,493,113	57,836,828	283,543,985	10.9%
2008	53,284,030	82,366,645	108,053,774	63,144,175	306,848,624	8.2%
Change	6.5%	9.6%	7.5%	9.2%	8.2%	

Table 7.20

Other KPB Annual Non-Taxable Sales by Quarter - in \$						
	1st Quarter	2nd Quarter	3rd Quarter	4th Quarter	Total	Annual Change
1995	99,675,088	132,296,452	180,250,465	119,514,988	531,736,993	
1996	88,014,985	119,595,497	146,949,066	111,277,773	465,837,321	-12.4%
1997	89,854,620	128,437,816	196,125,528	142,494,811	556,912,775	19.6%
1998	120,114,866	161,949,186	177,088,528	154,318,479	613,471,059	10.2%
1999	103,098,504	129,963,020	171,408,674	141,284,152	545,754,350	-11.0%
2000	90,968,620	128,772,460	159,001,471	130,219,854	508,962,405	-6.7%
2001	132,494,951	159,776,885	217,531,434	243,316,454	753,119,724	48.0%
2002	117,687,682	158,509,553	193,795,996	182,386,908	652,380,139	-13.4%
2003	116,081,348	150,124,562	214,012,638	172,336,749	652,555,297	0.0%
2004	120,093,554	130,263,317	252,228,971	381,431,835	884,017,677	35.5%
2005	143,781,277	179,845,245	248,490,852	399,801,759	971,919,133	9.9%
2006	126,605,019	193,251,551	248,896,099	425,014,818	993,767,487	2.2%
2007	147,009,457	177,946,269	238,138,600	451,238,998	1,014,333,324	2.1%
2008	144,318,922	227,737,820	282,385,598	519,263,846	1,173,706,186	15.7%
Change	-1.8%	28.0%	18.6%	15.1%	15.7%	

Table 7.21

Local Officials Directory

Kenai Peninsula Borough officials of the various governing bodies are listed on the following pages.

Officials listed are those who held office at the time of printing the report. Annual elections for public officials are held each October. For information regarding current public officials, check the appropriate website.

Kenai Peninsula Borough – <http://www.borough.kenai.ak.us/>

Kenai Peninsula Borough School District – <http://www.kpbsd.k12.ak.us/>

City of Homer – <http://www.ci.homer.ak.us/>

City of Kenai – <http://www.ci.kenai.ak.us/>

City of Seldovia – <http://www.cityofseldovia.com/>

City of Seward – <http://www.cityofseward.net/>

City of Soldotna – <http://www.ci.soldotna.ak.us/>

Local Officials Directory

Kenai Peninsula Borough Mayors

Kenai Peninsula Borough

Mayor David R. Carey 144 North Binkley
Soldotna, AK 99669
907-262-4441

City of Homer

Mayor Jim Hornady 491 East Pioneer Ave.
Homer, AK 99603
907-235-8121

City of Kachemak

Mayor Philemon Morris PO Box 958
Homer, AK 99603
907-235-8897

City of Kenai

Mayor Pat Porter 210 Fidalgo Street, Suite 200
Kenai, AK 99611
907-283-7535

City of Seldovia

Mayor Dick Wyland Drawer B
Seldovia, AK 99663
907-234-7643

City of Seward

Mayor Clark Corbridge PO Box 167
Seward, AK 99664
907-224-4046

City of Soldotna

Mayor Peter Miccichi 177 North Birch
Soldotna, AK 99669
907-262-9107

Table 8.1

Local Officials Directory

Kenai Peninsula Borough Mayor & Assembly				
144 N. Binkley Soldotna, Alaska 99669 Phone 907-714-2160 Assembly/Clerk Fax: 907-714-2388 Assembly e-mail: assemblyclerk@borough.kenai.ak.us				
Office / District	Name / Address	Phone / Fax / E-Mail	Term Expires	Previously Elected
Borough Mayor	David R. Carey 144 N. Binkley St. Soldotna, AK 99669	714-2150 W dcarey@borough.kenai.ak.us	2011	
Assembly 1 Kalifornsky	Gary Knopp 50465 Patrick Drive Kenai, AK 99611	283-9494 H 283-9800 F pa12gary@hotmail.com	2009	2006
Assembly 2 Kenai	Hal Smalley 105 Linwood Lane Kenai, AK 99611	283-7469 H hvsmalley@yahoo.com	2011	
Assembly 3 Nikiski	Gary Superman P.O. Box 8425 Nikiski, AK 99635	776-8448 H 776-8098 F 252-5264 W gsuperman@gci.net	2010	1989, 2001, 2004
Assembly 4 Soldotna	Pete Sprague - Vice President 188 Farnsworth Blvd. Soldotna, AK 99669	262-4073 H 262-8615 F psprague@acsalaska.net	2010	1998, 2001, 2002, 2004
Assembly 5 Sterling / Funny River	Charles "Charlie" Peirce Sterling AK 99672	260-6647 cpierce@gci.net	2011	
Assembly 6 East Peninsula	Ron Long P.O. Box 2464 Seward, AK 99664	224-7068 H 224-5707 F rlms@ptialaska.net	2009	2000, 2003, 2006
Assembly 7 Central	Paul Fischer P.O. Box 889 Kasilof, AK 99610	262-9269 H 262-4902 F akjfischer@hotmail.com	2010	1998, 2001, 2002, 2004, 2007
Assembly 8 Homer	Bill Smith P.O. Box 150 Homer, AK 99603	235-8932 H bsmith@xyz.net	2011	2006, 2008
Assembly 9 South Peninsula	Milli Martin - President P.O. Box 2652 Homer, AK 99603	235-6652 H 235-6652 F millimom@xyz.net	2009	2000, 2002, 2003, 2006
Borough Clerk	Johni Blankenship 144 N. Binkley St. Soldotna, AK 99669	714-2160 262-8615 Fax assemblyclerk@borough.kenai.ak.us		

Table 8.2

Local Officials Directory

KENAI PENINSULA BOROUGH		
PLANNING COMMISSION MEMBERS		
Member	Contact Information	Term Expires
CHAIRMAN Philip Bryson P.O. Box 1041 Kenai, Alaska 99611-1041	283-4672 work 283-4428 home	Kenai City Term Expires July 31, 2010
VICE CHAIRMAN Blair Martin P.O. Box 1776 Soldotna, Alaska 99669-1776	283-5227 - home	Kalifornsky Beach Term Expires July 31, 2009
JoAnne Collins P.O. Box 341 Anchor Point, Alaska 99556-0962	235-8071 home	Anchor Point/Ninilchik Term Expires July 31, 2010
Linda Murphy P.O. Box 4124 Soldotna, Alaska 99669	262-1686 - home	Soldotna City Term Expires July 31, 2011
Dr. Rick Foster P.O. Box 3328 Homer, AK 99603-3328	235-9100 - home	Homer City Term Expires July 31, 2010
Mari Anne Gross 57485 Clover Avenue Homer, Alaska 99603	235-7330 - home	Southwest Borough Term Expires July 31, 2011
Sue McClure P.O. Box 3686 Seward, Alaska 99664-3686	907-224-6784 - home	Seward City Term Expires July 31, 2011
Harry Lockwood 37085 Rafie Court Soldotna, Alaska 99669		Ridgeway Term Expires July 31, 2010
James Isham P.O. Box 51 Soldotna, Alaska 99669-0051	262-9200 - home	Sterling Term Expires July 31, 2009
Brent Johnson 20773 Porcupine Lane Clam Gulch, Alaska 99568-9713	262-4763 - home	Kasilof/Clam Gulch Term Expires July 31, 2009
Paulette Bokenko-Carluccio P.O. Box 116 Seldovia, Alaska 99663-0278	399-3711 - home	Seldovia City Term Expires July 31, 2009
Todd Petersen P.O. Box 651 Seward, Alaska 99664-0651	288-5050 - home 224-3350 - work 224-2388 - work fax	East Peninsula Term Expires July 31, 2010
Jason Tauriainen P.O. Box 7373 Nikiski, Alaska 99635-7373	776-3988 - home	Northwest Borough Term Expires July 31, 2011

Email address for the Planning Commission: planning@borough.kenai.ak.us

Fax Number for the Planning Commission: 907-262-8618

Table 8.3

Local Officials Directory

Kenai Peninsula Borough School District			
148 North Binkley Street Soldotna, AK 99669 907-262-5846			
<u>Board of Education</u>			
Sammie Crawford - President District 1	36615 Chinulna Drive Kenai, AK 99611	904-283-9271	Term Expires 2010
Sunni Hilts - Vice President District 9	P.O. Box 144 Seldovia, AK 99663	907-234-7692	Term Expires 2010
Lynn Hohl - Treasurer District 6	P.O. Box 333 Seward, AK 99664	907-224-7300	Term Expires 2010
Gregory Gabriel, Jr. District 2	P.O. Box 3392 Soldotna, AK 99669	907-394-4604	Term Expires 2009
Joe Arness District 3	P.O. Box 1470 Kenai AK 99611	907-776-8089	Term Expires 2011
Penny Vadla District 4	399 W. Riverview Avenue Soldotna, AK 99669	907-262-7249	Term Expires 2011
Marty Anderson District 5	P.O. Box 1388 Sterling, AK 99672	907-260-7500	Term Expires 2009
Bill Holt District 7	P.O. Box 794 Kasilof AK 99610	907-283-7260	Term Expires 2011
Elizabeth Downing District 8	1247 Bay Avenue Homer, AK 99603	907-235-8555	Term Expires 2009
Student Representative Theresa Ramponi	Skyview High School 46188 Sterling Highway Soldotna, AK 99669		Term Expires 9/2009

Table 8.4

<u>Administration</u>
Dr. Donna Peterson, Superintendent of Schools Steve Atwater, Assistant Superintendent Dave Jones, Assistant Superintendent Melody Douglas, Chief Financial Officer

Table 8.5

Local Officials Directory

Kenai Peninsula Borough Department Directors	
Switchboard	(907) 262-4441 or (800) 478-4441
Assessing	Shane Horan
Capital Projects	Kevin Lyon
Clerk	Johni Blankenship
Finance	Craig Chapman
Legal	Colette Thompson
Maintenance	Dave Tressler
Resource Planning	Max Best
Road Maintenance	Jim Conner
Solid Waste	Jack Maryott

Table 8.6

Kenai Peninsula Borough Economic Development Agencies
<p>Kenai Peninsula Economic Development District - EDD 14790 Kenai Spur Highway, Ste. 106A Kenai, AK 99611 907-283-3335</p>
<p>Kenai Peninsula Tourism Marketing Council - KPTMC 35477 Kenai Spur Highway, Ste. 205 Soldotna AK 99669 907-262-5229</p>
<p>Kenai Peninsula Resource Conservation and Development, Inc. Trading Bay Plaza, Suite 150 PO Box 800, Kenai, AK 99611 907-283-7493</p>

Table 8.7