

Index

	Page #
Introduction -----	2
Executive Summary -----	5
Kenai Peninsula Borough	
Sales - KPB Finance Department-----	13
Construction – City administrations throughout KPB -----	31
Employment St of AK, Dept of Labor -----	43
Population – U.S. Census Bureau, Alaska Department of Labor-----	47
Homer	
Sales - KPB Finance Department-----	53
Construction – City of Homer -----	61
Cost of Food – University of Fairbanks Cooperative Extension -----	69
Kenai	
Sales - KPB Finance Department-----	71
Construction – City of Kenai-----	79
Cost of Food – University of Fairbanks Cooperative Extension -----	87
Seldovia	
Sales - KPB Finance Department-----	89
Construction – City of Seldovia -----	97
Seward	
Sales - KPB Finance Department-----	101
Construction – City of Seward-----	109
Cost of Food – University of Alaska Fairbanks Cooperative Extension -----	117
Soldotna	
Sales - KPB Finance Department-----	119
Construction – City of Soldotna -----	127
Cost of Food – University of Fairbanks Cooperative Extension -----	135
Other	
Sales – KPB Finance Department -----	137
Directory of Local Officials-- -----	145

Data Sources are listed for each subsection.

Introduction

Kenai Peninsula Borough (KPB) staff develops quarterly reports containing economic data from throughout the area for use by businesses, agencies, and other entities to make planning and management decisions.

The publication is divided into eight sections: Kenai Peninsula Borough, Homer, Kenai, Seldovia, Seward, Soldotna, Other KPB, and a Local Officials Directory.

To provide unity within the document, certain conventions are applied:

- In the real estate section, the following abbreviations apply:
 - RN - Residential New
 - RA - Residential Alteration/Addition
 - CN - Commercial New
 - CA - Commercial Alteration/Addition

- In Sales and Employment sections, the following industry abbreviations apply:
 - AFF – Agriculture, Forestry and Fisheries (Includes Fish Buyers)
 - Min – Mining (Includes Oil & Gas Extraction and Production)
 - Const – Construction
 - Manu – Manufacturing (Includes Oil & Gas Manufacturing and Fish Processing)
 - TCPU – Travel, Communications, and Public Utilities
 - Whole – Wholesale Trade
 - Retail – Retail Trade
 - FIRE – Finance, Insurance and Real Estate
 - Service – Services
 - Govt – Public Administration, Education and Service

- Information sources for each section are listed in the index.

- General information applicable to all sections is provided in the Kenai Peninsula Borough section.

- Percentages of parts may not total 100%, due to rounding.

Information presented will assist in decision-making by providing economic and demographic information in graphic, table and text form. Local and state government officials; local, state and federal agencies; businesses within the Borough and elsewhere; and private citizens use data contained in the publication.

Data is received from various sources and is subject to change as updates, revisions and corrections are received. The KPB makes no claims to accuracy or completeness of information provided. Only summary information is published. For further detail, contact Jeanne Camp, Economic Analyst, Kenai Peninsula Borough, 907-714-2336, or the data source listed in the index.

Quarterly reports are available electronically on the KPB website located at <http://www.borough.kenai.ak.us>.

To correct your mailing address or to be added to or deleted from the mailing list for this report, please email jcamp@borough.kenai.ak.us or call 907-714-2336. Be certain to identify yourself and the complete mailing address to be added or deleted. For additions, an email address is appreciated to be used for notification of errors.

The Kenai Peninsula Borough wishes to thank all entities listed below for data provided for this publication.

Alaska Department of Labor and Workforce Development (AK DOL)

City of Homer

City of Kenai

City of Seldovia

City of Seward

City of Soldotna

Kenai Peninsula Borough Finance Department, Sales Tax Division

University of Alaska Fairbanks Cooperative Extension

The writer wishes to thank those persons who gave of their time to review this document, finding errors and making suggestions that result in a more professional and accurate document. Those individuals include Jane Stein, Community Leader; Sylvia Vinson, KPB Planning Department; and Betty Glick, former Assembly member.

Functions of the CEDD and the EDD

Recent changes in the KPB have caused changes in the functioning of the CEDD. As a result of Proposition 5 in the recent election, the sales tax rate in the KPB has been capped at 2%. The budget for the coming fiscal year was developed using revenues expected as a result of an increase to 3%. Among other consequences, the newly elected mayor, John J. Williams, has the task of revising the budget downward. Part of that revision includes dissolution of the Community and Economic Development Division of the Mayor's Office. The Grant's Manager remains active with an office in the Borough building. Duties include administration of Borough grants, both those received from other entities, and those granted to other establishments. Duties of the Oil & Gas Liaison have been changed and moved to the main Borough building. The Economic Analyst position will also be moved from the current office suite, probably to the main building. The Business Development Manager position has been eliminated.

What is a "Moving Average Trendline?"

Charts in the KPB economic reports frequently include "moving average trendlines." The purpose of a trendline is to demonstrate the average of data groupings and how that average relates to averages of similar groupings within the chart.

Imagine that a bar chart illustrates twelve quarters of data. The trendline begins at the fourth entry in the series and marks the point representing the average of the first through the fourth numbers in the series, in this case a 1st, 2nd, 3rd and 4th quarter value, one year. The trendline continues to the right in the chart. As the trendline reaches the next entry in the series, the line will move to the point on the scale representing the average of the second through the fifth entries in the series – still four quarters of data, but this time those values would be the 2nd, 3rd and 4th quarter of the first year plus the 1st quarter of the second year.

The process continues through the chart. As the line moves through the chart, it drops the entry marking the beginning of the trend point average, adds the entry just ahead of the previous set of four and indicates the average of the new set of four numbers in the series. The resulting "smoothing" effect allows the reader to more easily see change from one year to the next.

Executive Summary

Third quarter gross sales total \$712,923,275, topping \$700,000,000 for the first time ever and gaining 3.1% over 2004 third quarter. Taxable sales improved as well, gaining 3.8% to total \$279,414,727. Permitted construction project values declined 67.7% to \$12,117,491, but following the remarkable values of 2004, this was not surprising. Volume of permitting also declined from 116 permits to 95 permits. Labor force totals continue to increase, as do employment totals, resulting in continued declining unemployment rates. September's 2005 rate was 7.2%, compared to 7.9% during September 2004.

Highlights in the Oil & Gas industry include Agrium's announcement that it would not be closing its plant for at least another year because it has located a source of gas supplies to remain operative another year. Pioneer has acquired up to 50 percent of ConocoPhillip's Cosmopolitan unit offshore in lower Cook Inlet. Forest Oil announced in August their intention to drill five onshore wells as rigs become available.

During September, an agreement was submitted to the Regulatory Commission of Alaska for approval to use CIGGS, the privately owned Cook Inlet Gas Gathering System. The agreement between Marathon Oil, Unocal Corp., Agrium, Cook Inlet gas producers, Enstar Natural Gas Co. and the State of Alaska opens the system to users other than the owners, Marathon and Unocal. The main issue relates to the Alaska Right-of-Way Leasing Act requiring that pipelines crossing state lands or waters be regulated as common carrier lines. The proposed agreement would provide shipping access to both Agrium and Aurora, who in turn will make prepayments to cover costs associated with installation of meters and control instrumentation for the additional infrastructure.

Initial reports indicate commercial fisherman experienced a satisfactory harvest, as both fish count and price per pound were better than last year. Specific details are not yet available. Preliminary tourism data is also positive.

SALES

Reported gross sales within the KPB reached \$712,923,275, an increase of 3.1% over one year ago, and an increase of \$21,599,548 in sales. Of the ten active industries in the KPB, four experienced double-digit gains, five had single-digit gains, and only one reported a decline.

Taxable sales gained 3.8% reaching \$279,414,727, as six industry sectors reported gains and four experienced declining sales. Taxable sales were \$10,337,376 greater than third quarter 2004.

Quarterly Sales

Gross by Industry. Retail sales increased 4.5% in this large sector, from \$224,495,400 during third quarter 2004 to \$234,519,707 during the most recent quarter, a gain of \$10,024,307. Construction sales gained 11.6% or \$7,754,613, to reach \$74,807,797. Mining sales totaled \$45,642,802, gaining \$6,642,045 or 17.0% over third quarter 2004. The 2.5% gain in the service sector resulted in sales of \$122,989,270, an increase of \$2,976,089. Manufacturing reported a \$2,781,990 sales increase, 2.9%, with sales of \$99,989,169 for the quarter. Agriculture, forestry and fishing (AFF) sales increased by \$2,517,345 to total \$18,212,362, a 16.0% gain. Sales in finance, insurance and real estate (FIRE) grew by \$1,332,890 or 7.8% to total \$18,384,551. Sales in the transportation, communication and public utilities (TCPU) sector reached \$55,571,034, gaining 0.2% or \$138,574 over the \$55,432,460 reported sales of third quarter 2004. Lastly, government sales experienced the largest percentage gain, 29.6%, although the smallest monetary increase, reaching \$2,723, insignificant in the KPB total of \$712,923,275 sales.

The only sector with declining sales was wholesale goods where total sales dropped \$12,571,028 to \$42,794,676, a 22.7% decline. (See page 15 for detail.)

Taxable by Industry. The standard continues to rise as third quarter taxable sales increased 3.8% to reach \$279,414,727, a gain of \$10,337,376 over third quarter 2004. Six of ten industry sectors marked increased sales during third quarter 2005. Retail sales make up 57.7% of total taxable sales, and gained 5.1% over 2004 with sales reaching \$161,144,513. Last year, those sales totaled \$153,382,551. Service sales increased \$1,890,165 from \$69,142,137 to \$71,032,302, a gain of 2.7%. Tourism activity provides over twenty percent of taxable service sales. TCPU sales increased \$1,651,784 to reach \$22,873,141, a 7.8% gain for the quarter. AFF sales increased 10.6% or \$209,702, to total \$2,189,268. Finally, sales in the FIRE sector increased 0.7% or \$49,146 to a total of \$6,717,372. The sales by government entities totaled \$11,907, a gain of 29.6% but inconsequential in the total picture.

Four sectors experienced declining sales for the quarter. Reported mining sales dropped \$826,726 to \$1,081,489, a 43.3% decrease. Construction sales dropped 5.8% from \$3,278,174 to \$3,089,078. Sales in the wholesale sector were down 1.5% from \$7,644,161 to \$7,525,987. Lastly, the \$3,749,670 in the manufacturing sector sales marked a 2.4% decrease. (See page 16 for detail.)

Gross by Area. Gross sales increased 3.1% with all areas except the Other KPB area reporting gains, to total \$712,923,275. Seldovia had the greatest percentage gain, 23.5%, as sales increased \$424,707 to \$2,233,774, due in part to strong retail sales. Kenai sales increased 13.7% to \$111,294,018 with strength in the construction sector. Homer gained 6.2% with sales totaling \$99,774,615, also with strength in the construction sector. With sales of \$113,083,093, Soldotna sales increased 5.5% with a \$4 million increase in retail sales. Seward sales increased 3.9% to \$66,446,710.

Sales in Other KPB were down 2.0% to \$320,091,065. (See detail on page 17.)

Taxable by Area. All six areas of the KPB reported increased quarterly sales, resulting in a 3.8% gain. Kenai sales increased 6.5% to \$42,640,243 with strength in construction and manufacturing. Soldotna's \$69,580,021 in sales marked a 5.1% increase over last year when sales reached \$66,177,951. Seward sales reached \$38,375,511, a 3.5% increase over 2004 sales of \$37,077,424. Homer sales grew by 1.7% from \$49,027,379 to \$49,872,039. Lastly, Seldovia's \$1,199,541 in taxable sales marked a 1.5% increase over 2004 when sales reached \$1,182,138. (See Page 18 for detail.)

Year-to-Date Sales

Year-to-date gross sales gained 10.7% over 2004 while taxable sales were up 4.5%.

Gross by Industry. KPB year-to-date September 30 sales of \$1,693,742,030 were 10.7% greater than one year ago when sales reached \$1,529,501,413. The gain is equivalent to \$164,240,617 in sales. Manufacturing sales had the greatest monetary growth, up \$53,406,415 to \$192,260,878, a 38.5% increase with strength in various areas of the sector that includes fish processing and oil & gas value-added manufacturing. Construction sales increased \$48,933,525 to reach \$186,900,985, a 35.5% gain. TCPU sales of \$182,545,476 were \$39,854,769 above 2004, a 27.9% increase. Retail sales increased 5.0% or \$26,863,299 to total \$565,833,444. Mining sales increased \$10,160,344 or 9.2% to reach \$121,060,842. Service sales of \$254,829,851 were \$9,436,050 ahead of 2004, marking a 3.8% increase. AFF sales followed with a 22.7% gain for \$26,928,513 in sales, \$4,981,538 above 2004. Finally, FIRE sales grew by \$1,936,107 or 4.3% to \$46,903,113. The \$4,255 increase in government sales to \$35,623 is inconsequential.

The only sector with decreasing sales was wholesale, declining from \$147,778,990 to \$116,443,305, down 21.2%. (See detail on page 19.)

Taxable by Industry. Five of ten industries report increased sales during the first nine months of 2005 over those of 2004 with year-to-date taxable sales of \$643,804,637. Sales in the large retail sector increased \$18,634,824 or 5.2% from \$358,841,292 to \$377,476,116 during the same period 2005. TCPU sales increased \$6,216,939 to total \$67,933,763. Services gained \$4,277,183 growing from \$132,838,047 to \$137,115,230. AFF sales increased by \$330,855 to \$4,874,201. Lastly, government sales of \$35,623 were up by \$4,320.

Five sectors had declining sales. While sector gains were in the millions of dollars, declines were all less than one million. Mining sales dropped \$838,994 to \$3,199,393. Sales in the wholesale sector declined to \$19,847,684, down \$289,295. Manufacturing sales of \$7,817,044 were \$276,567 less than year-to-date 2004. Sales in the FIRE sector

reached \$17,230,305, down \$153,290. Lastly, construction sales decreased \$130,023 to \$8,275,278. (See detail on page 20.)

Gross by Area. Year-to-date gross sales grew by 10.7% as all reporting areas increased sales over 2004. Kenai sales increased 20.5% to \$288,274,479 with strength in construction, TCPU and retail sales. Seward sales increased to \$151,328,540, an 18.4% gain with strong growth in various sectors but notably in construction. Homer sales grew by 9.2% to reach \$237,823,817 with strength in retail and construction sales. Seldovia's 8.3% increase brought total year-to-date sales to \$5,615,390. Soldotna sales gained 0.1%, reaching \$266,654,393 with strength in retail sales. Sales in the Other KPB area gained 10.6% to total \$744,045,411. (See detail on page 21.)

Taxable by Area. KPB taxable sales increased 4.5% overall to \$643,804,637 as all areas experienced gains. Seward had the greatest percentage increase, 6.1%, with sales of \$73,796,694 for the first three quarters of 2005. Soldotna sales grew 5.2% to \$160,455,467, followed closely by Other KPB sales, which gained 5.1% to total \$181,630,361. Kenai sales gained 3.5% reaching \$109,555,176, while Homer sales, \$115,662,725, were 2.8% greater than sales reported last year at this time. Seldovia taxable sales increased 0.6% to \$2,704,214. (See detail on page 22.)

Annual Sales

KPB 2004 annual gross sales increased 16.4% over 2003, reaching \$2,236,865,510, the first time KPB annual sales topped the \$2 billion dollar mark. Seven sectors had improved sales while three experienced declining sales. Each of the six areas experienced increased gross sales.

Taxable sales increased 6.5% from 2003 to 2004 with sales reaching \$780,295,688, following a 1.2% increase one year ago and a 2.6% gain from 2001 to 2002. All reporting areas increased taxable sales from 2003 to 2004.

Gross by Industry. Gross sales during 2004 increased \$315,733,937 over those of 2003. The 16.4% increase brought total reported gross sales to \$2,236,865,510. The wholesale sector increased \$172,390,996, or 88.8%, to sales of \$366,603,918. Mining sector sales of \$165,354,111 were \$58,792,372 greater than during 2003, a 55.2% increase. Increasing by \$55,200,204, the retail sector increased sales by 8.6% with a total of \$699,837,432. The \$35,552,082 increase in TCPU sales marked a 22.4% gain to \$193,924,248. Service sales increased 11.3%, or \$31,486,970, to \$310,768,193. Lastly, AFF sales increased \$5,621,925 or 25.5% to reach \$27,631,235.

Three sectors marked sales declines during 2004. The decline in government sales, 16.4%, is inconsequential with total sales of \$35,105. The 8.1% decline in construction sales caused total sales to drop from \$258,251,958 to \$237,336,814 during 2004, in spite of tremendous construction permitting. Sales follow permitting. The 8.1% decline is equal to \$20,915,144 in sales. Manufacturing also saw decreasing sales, down

\$28,733,878, or 14.4% with sales totaling \$170,708,461 during 2004. (See detail on page 23.)

Taxable by Industry. Taxable sales increased 6.5% during 2004 over 2003 with seven of ten industries marking gains. Mining had the largest percentage increase, 12.6%, as sales reached \$5,502,300. AFF sales rose 10.3% to \$5,525,243 while sale of wholesale goods increased 8.3% to \$26,290,768. Sales in the large retail sector increased 7.6%, equivalent to \$32,423,092, to total \$461,629,346. Taxable manufacturing sales increased to \$9,859,946, a 6.7% gain. Services, the second largest sector, had sales of \$154,952,698, a 7.0% gain or \$10,140,348 more in sales than the previous year. The 1.6% increase in TCPU sales reflects a \$1,334,014 increase in sales, to \$82,707,524.

Taxable sales in the FIRE sector decreased 1.5% or \$340,991, to \$22,549,786. Sales in the construction sector were down 0.1% to \$11,243,037. The 16.4% decline in government sales is inconsequential with sales of \$35,040. (See detail on page 24.)

Gross by Area. As KPB sales grew by 16.4%, each of the reporting areas also experienced increased sales. With the largest percentage gain, Kenai sales rose 67.8% over 2003 to total \$475,463,260. The \$192,048,598 increase was largely a factor of increased wholesale and retail sales but growth was strong in every sector with the exception of manufacturing. Seldovia gross sales grew by 14.7%, reaching \$8,329,831 for the year. The Other KPB area sales increased 8.5% to \$935,151,337 while Soldotna, with \$361,243,013 in sales, marked a 6.9% gain. Homer's 6.0% sale increase resulted from total sales of \$290,454,399 as the TCPU, wholesale and FIRE sectors all reported double-digit expansion. Seward sales rose 5.9% to reach \$166,223,670 as both the retail and service sectors showed significant gains. (See detail on page 25.)

Taxable by Area. As total KPB taxable sales increased 6.5% for the year, all areas also experienced increased sales. Kenai's 14.3% gain was impacted by retail sales growth due in part to Home Depot's first full year of operation as Kenai sales topped out at \$138,672,979. Homer sales increased 6.3% to \$139,999,037 while Soldotna sales gained 4.9% to total \$200,044,811. Seward sales of \$79,955,659 marked a 4.7% increase while Other KPB sales increased 4.1% with \$218,236,890 in reported sales. Sales in Seldovia increased 0.3% to \$3,386,312. (See detail on page 26.)

CONSTRUCTION PERMITTING

Quarterly Permitting

By Area, Value. Permits issued within the KPB during third quarter had a total appraised value of \$11,117,491. This 67.7% decrease is due to strong permitting activity during 2004, a drop is not unexpected. Seward's permit values dropped 71.2% to \$653,661; Homer's permitting value, \$4,312,500, was down 54.8%, and Soldotna values were down 87.0%.

Seldovia permitted projects with a value of \$30,500, after a year with no activity. Kenai also increased permitting values with projects totaling \$4,035,100, a 102.6% increase.

By Type, Value. New residential permit values provided 40.1% of value with \$4,853,170 in assessed value permitting during third quarter 2005. New commercial permits added 40.0% of the total with \$4,841,400. Commercial alteration/addition permit values of \$1,627,150 provided 13.4% of the total while residential alteration permits issued during the quarter had a total value of \$795,771 or 6.6%. (See detail on page 32.)

By Area, Volume. Kenai issued 33 permits, two more than one year ago. Homer issued 27 permits, fifteen fewer than 3rd quarter 2004. Soldotna issued 20 permits, down from the 24 that were issued one year ago. Seward issued 13 permits, six less than third quarter 2004 when 19 were issued. The remote community of Seldovia issued two construction permits. (See detail on page 33.)

By Type, Volume. Of the 93 third quarter permits, 35 were issued for residential alteration or additions. New residential projects added 32 with 22 permits issued for commercial alterations. Six permits were issued for new commercial projects. (See detail on page 34.)

Year-to-Date Permitting

Year-to-date September 30 permit values reached to \$40,359,821, down from the strong showing of 2004 when several large projects were permitted and a new record high was set. Although the values were less, the volume increased to 300 from last year's 259. The record high volume was set during 2002 when 302 permits were issued YTD September 30.

By Area, Value. Although the permit value drop seems large, the 2005 YTD total is fourth highest on record, barely less than the third highest, but significantly behind the 1995 total when the SeaLife Center was permitted and 2004 when the Central Peninsula General Hospital addition was approved, as well as the Fred Meyer expansion, and several other large projects. Homer, issuing 46.2% of the value, has permitted \$18,660,400 in construction projects YTD. Soldotna reported \$11,339,520 in permit value, 28.1% of the KPB total. Kenai's total reached \$7,017,900 and 17.4% of the total, while Seward issued \$2,830,501 for 7.0%. Seldovia issued permits totaling \$511,500 in assessed value, year to date. (See detail on page 35.)

By Type, Value. New residential total permit value was strong with a total of \$15,884,025 being permitted, 39.4% of the KPB total. The total value of new residential permits issued during the first nine months of 2005 was greater than all prior full year's permitting except for one, 2004. Even then, the annual value was only \$51,319 less than this year's first three quarters.

New commercial permitting has provided 42.2% of total value YTD, \$17,043,248. Commercial alteration permits added \$5,384,077 and residential alteration another \$2,048,471 to the total. (See detail on page 36.)

By Area, Volume. There were 300 permits issued within the KPB cities, as of September 30. Homer issued 92 permits, 30.7% of the total. Kenai and Soldotna each issued 76 permits or 25.3%. Seward issued 47 for 15.7% and Seldovia has issued nine permits YTD. (See detail on page 37.)

By Type, Volume. Of the 300 permits issued during the first three quarters of 2005, 34.0% or 102 were for residential alterations or additions. Ninety-nine permits were for new homes. Commercial alterations added 63 permits and new commercial permits provided the final 36. (See detail on page 38.)

Annual Construction

Construction permits are required by KPB cities, but not by the KPB, resulting in incomplete construction activity data. Permit values during 2004 totaled \$84,041,457, a 92.7% increase over 2003 and the highest annual total value on record. There were 312 permits issued during 2004, 7.1% fewer than the 336 issued during 2003, but third highest on record.

By Area, Value. Soldotna's \$37,296,926 in construction permit assessed values provided 44.4% of KPB 2004 annual value; a 369.0% increase over 2003 permit values. Homer's \$24,070,631 total value added 28.6% to the KPB total, marking a 57.0% increase over 2003. Seward permit values increased 121.9% for the year to \$17,711,150, providing 21.1% of the annual total. Kenai permit values dropped 54.2% to \$4,786,550, providing 5.7% of the KPB total. Seldovia's \$176,200 value provided the remaining 0.2%. (See detail on page 39.)

By Type, Value. Total permit values for 2004 were 92.7% greater than those of 2003. The value of those permits was \$84,041,457. New projects provided 85.7% of permit activity with commercial and residential permits providing 66.7% and 19.0% of the total, respectively. New commercial values of \$56,079,343 led the way with new residential permit values totaling \$15,935,344. Commercial alteration/addition permit values totaled \$9,146,486 or 10.9% of the total. Finally, residential alteration/addition permits added \$2,880,284 for 3.4% of the KPB total. New commercial permit values were 254.5% above 2003 while residential alteration/ addition values were up 26.3%. New residential values increased 1.3% but commercial alteration/addition total value was down 6.4%. (See detail on page 40.)

By Area, Volume. During 2004 Homer issued 108 of the 312 permits, providing 34.6% of the KPB total. Kenai issued 79 permits while Soldotna issued 67 permits, 25.3% and 21.5%, respectively. Seward issued 54 permits, 17.3% of the total while Seldovia's 4 permits added 1.3% of the volume. Homer and Seward increased permit volume over 2003 with Homer issuing 25.6% more permits than one year ago and Seward's count increased by 8.0%.

On the down side, areas with declining permit activity include Kenai, down 30.7%, Soldotna down 9.5% and Seldovia issued 66.7% less than one year ago. Total Borough permitting was down 7.1% from the 2003 level. (See detail on page 41.)

By Type, Volume. Commercial alteration/addition annual activity for 2004 decreased 7.1% to 312 permits from 336 during 2003. New residential activity shows 94 permits were issued, down from 104 permits each of the last two years. Ninety-six residential alteration/addition permits were issued, 2.1% more than during 2003. New commercial activity was stable at 42 permits while commercial alteration/addition activity dropped from 96 to 80 permits. (See detail on page 42.)

EMPLOYMENT

Once again, the labor market increased, but employment increased to a greater extent, with the resultant decrease in unemployment. During July, August and September 2005, the labor force was larger by 333 persons, 210 persons, and 419 persons in relation to the same month during 2004.

During those same three months, the number of unemployed persons decreased 293, 251 and 139 persons from one year earlier. One would expect an increase in labor force to cause an increase in unemployment but, due to employment growth, the opposite occurred. Employment growth resulted in 626 more persons working during July 2005 than July 2004. August and September saw similar growth, with 461 and 558 additional persons working each month, respectively.

As a result of the above changes, KPB's unemployment rate has been decreasing. For the month of July, the rate decreased from 7.4% during 2004 to 6.2% during 2005. The August rate dropped from 7.4% to 6.4% and the September rate from 7.9% to 7.2% over the same period. Since 1993 the average September unemployment rate has been 8.8%, significantly above the 2005 rate, 7.2%. (See detail on pages 43-46)

POPULATION

Population estimates for 2004 show the KPB population at 50,980 persons, a 0.8% decrease for the year. Each of the incorporated cities also marked decreases. Homer dropped 9.1% to 5,332 while Kachemak City lost 0.6% to a total of 475 persons. Kenai also decreased, losing 4.4% to 6,809 residents. Seldovia decreased 5.7% to 263 and Seward lost 7.5%, down to 2,540 persons. Soldotna's population is down 5.6% to 3,767. Alaska's population, estimated at 655,435 for 2004, marked a 1.1% increase for the year. (See page 47 for detail.)

KPB Sales

Sales tax records provide data useful for predicting economic trends and provide a basis for administrative decisions. Data collected are specific to the area collecting and reporting sales but, by combining data from reporting communities, KPB trends can be determined. Routinely, three years or twelve quarters of information are revised each quarter. Sales data is provided by the KPB Finance Department, Sales Tax Division.

Homer sales and construction data reflects the impact due to annexation of 4.58 square miles which increased the total area of Homer by over twenty-eight percent. The annexation became effective April 1, 2002.

KPB sales data include detail from Homer, Kenai, Seldovia, Seward, Soldotna and "Other KPB" areas. "Other KPB" indicates areas within the KPB but outside the boundaries of the five incorporated cities. It also includes Kachemak City, which does not impose a sales tax. The 2% KPB sales tax is included in the city rates listed below, with revenues dedicated to funding the KPB school district. The balance is the tax imposed by each city with revenues being managed by that city.

The KPB does not provide an incentive for reporting non-taxable sales, resulting in incomplete Gross Sales data.

6.5%	6.0%	5.0%	4.0%	2.0%
Homer	Seward	Kenai	Seldovia	Other KPB
Seldovia (April - September)		Soldotna	(October - March)	

Gross and taxable sales data are received quarterly through Sales Tax Returns from businesses within the KPB. Sales that are exempt from sales tax include:

- Sales outside the Borough;
- Sales for resale;
- Sales to government agencies;
- Sales to tax exempt organizations; and
- Sales in excess of \$500.

Industry abbreviations used in sales data include the following:

- AFF - Agriculture, Forestry and Fisheries - includes Fish Buyers;
- Min - Mining - includes Oil & Gas extraction;
- Const - Construction;
- Manu - Manufacturing - includes Oil & Gas Manufacturing and Fish Processing;
- TCPU - Travel, Communications and Public Utilities;
- Whole - Wholesale Trade;
- Retail - Retail Trade;
- FIRE - Finance, Insurance and Real Estate;
- Service - Services;
- Govt - Public Administration, Education and Services.

KPB Sales

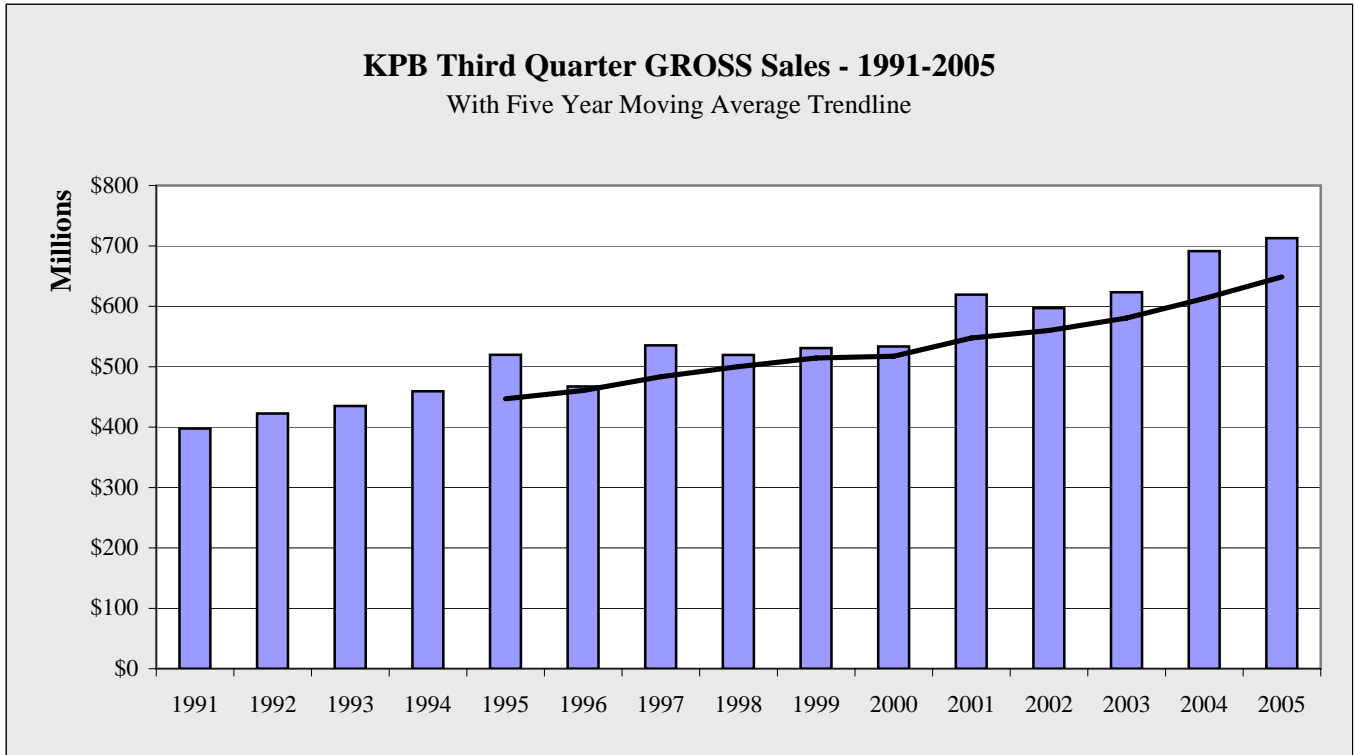

Chart 1.1

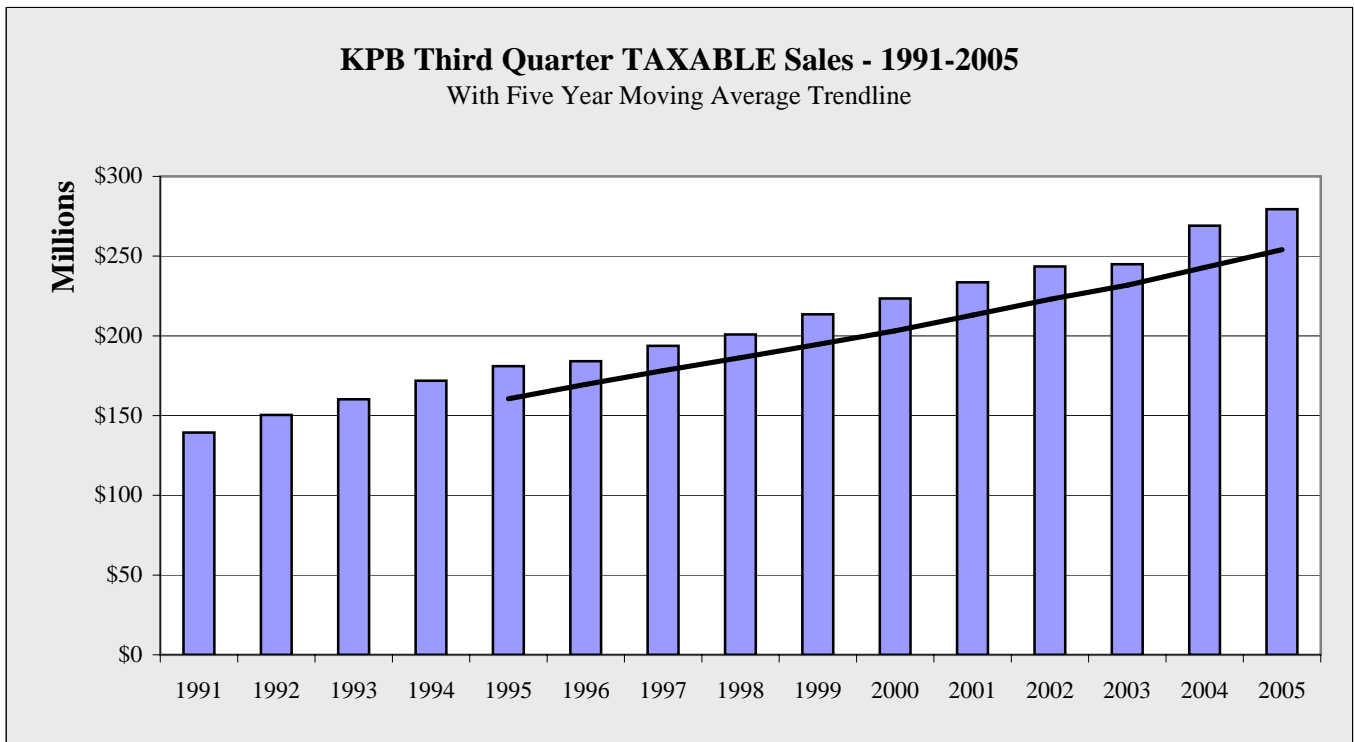

Chart 1.2

KPB Sales

KPB 3rd Quarter GROSS Sales by INDUSTRY - 1999-2005 - in \$								
	1999	2000	2001	2002	2003	2004	2005	Annual Change
AFF	25,699,730	16,087,099	11,255,799	9,835,705	13,491,140	15,695,017	18,212,362	16.0%
Min	22,762,273	36,716,025	35,734,043	26,316,221	30,366,980	39,000,757	45,642,802	17.0%
Const	53,692,037	60,347,340	86,781,531	72,113,003	81,917,870	67,053,184	74,807,797	11.6%
Manu	60,059,506	33,825,248	65,102,674	56,768,859	66,216,357	97,207,179	99,989,169	2.9%
TCPU	45,976,697	43,279,326	51,122,861	51,457,523	43,819,198	55,432,460	55,571,034	0.2%
Whole	48,350,292	56,037,950	56,194,826	57,145,760	60,869,241	55,365,704	42,794,676	-22.7%
Retail	171,652,352	181,293,959	195,058,287	198,420,434	201,806,657	224,495,400	234,519,707	4.5%
FIRE	15,295,826	13,551,624	16,361,489	15,233,449	16,119,572	17,051,661	18,384,551	7.8%
Service	87,382,828	92,333,294	101,637,009	109,778,499	108,559,994	120,013,181	122,989,270	2.5%
Govt	5,353	1,781	7,371	4,290	12,192	9,184	11,907	29.6%
Total	530,876,894	533,473,646	619,255,890	597,073,743	623,179,201	691,323,727	712,923,275	3.1%
Annual Change		0.5%	16.1%	-3.6%	4.4%	10.9%	3.1%	

Table 1.1

KPB 3rd Quarter GROSS Sales Ten Year Change by INDUSTRY - 1995 v. 2005 - in \$				
	10 Year Change			
	1995	2005	Percentage	Numerical
AFF	48,506,808	18,212,362	-62.5%	-30,294,446
Min	24,845,969	45,642,802	83.7%	20,796,833
Const	59,923,957	74,807,797	24.8%	14,883,840
Manu	59,664,211	99,989,169	67.6%	40,324,958
TCPU	70,330,736	55,571,034	-21.0%	-14,759,702
Whole	39,331,387	42,794,676	8.8%	3,463,289
Retail	136,831,941	234,519,707	71.4%	97,687,766
FIRE	12,018,075	18,384,551	53.0%	6,366,476
Service	68,347,630	122,989,270	79.9%	54,641,640
Govt	2,025	11,907	488.0%	9,882
Total	519,802,739	712,923,275	37.2%	193,120,536

Table 1.2

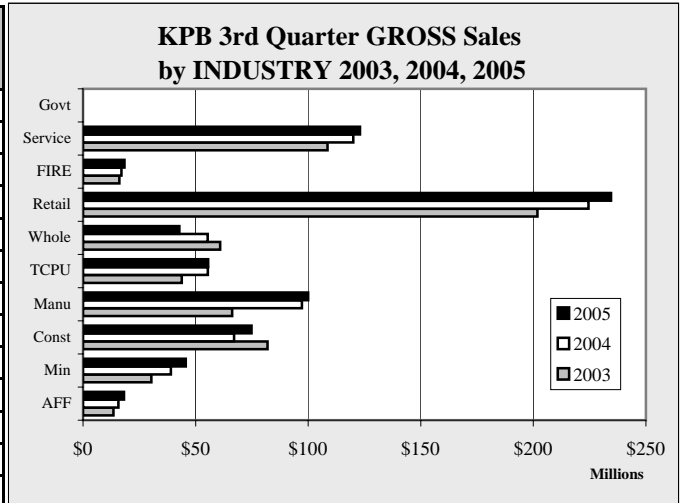

Chart 1.3

KPB 3rd Quarter GROSS Sales One Year Change by INDUSTRY - 2004 v. 2005 - in \$				
	1 Year Change			
	2004	2005	Percentage	Numerical
AFF	15,695,017	18,212,362	16.0%	2,517,345
Min	39,000,757	45,642,802	17.0%	6,642,045
Const	67,053,184	74,807,797	11.6%	7,754,613
Manu	97,207,179	99,989,169	2.9%	2,781,990
TCPU	55,432,460	55,571,034	0.2%	138,574
Whole	55,365,704	42,794,676	-22.7%	-12,571,028
Retail	224,495,400	234,519,707	4.5%	10,024,307
FIRE	17,051,661	18,384,551	7.8%	1,332,890
Service	120,013,181	122,989,270	2.5%	2,976,089
Govt	9,184	11,907	29.6%	2,723
Total	691,323,727	712,923,275	3.1%	21,599,548

Table 1.3

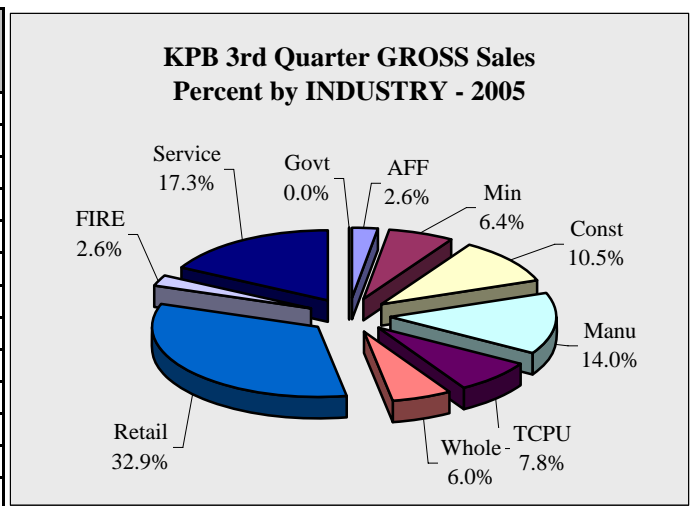

Chart 1.4

KPB Sales

KPB 3rd Quarter TAXABLE Sales by INDUSTRY - 1999-2005 - in \$

	1999	2000	2001	2002	2003	2004	2005	Annual Change
AFF	1,200,980	1,387,185	1,439,658	1,400,008	1,697,754	1,979,566	2,189,268	10.6%
Min	1,029,532	1,365,351	1,676,508	1,550,583	1,313,871	1,908,215	1,081,489	-43.3%
Const	2,984,509	2,912,742	3,052,052	3,288,688	3,316,609	3,278,174	3,089,078	-5.8%
Manu	3,249,141	3,521,436	3,503,699	3,717,020	3,333,206	3,843,780	3,749,670	-2.4%
TCPU	19,647,272	20,097,058	20,377,897	21,106,028	19,718,329	21,221,357	22,873,141	7.8%
Whole	5,397,023	6,335,381	6,323,351	6,316,722	7,103,240	7,644,161	7,525,987	-1.5%
Retail	118,892,395	124,077,139	131,159,386	136,536,484	139,052,180	153,382,551	161,144,513	5.1%
FIRE	5,291,396	5,945,402	6,675,601	6,917,181	6,490,125	6,668,226	6,717,372	0.7%
Service	55,857,912	57,808,788	59,321,464	62,644,991	62,844,657	69,142,137	71,032,302	2.7%
Govt	5,353	1,781	7,371	4,290	12,192	9,184	11,907	29.6%
Total	213,555,513	223,452,263	233,536,987	243,481,995	244,882,163	269,077,351	279,414,727	3.8%
Annual Change		4.6%	4.5%	4.3%	0.6%	9.9%	3.8%	

Table 1.4

KPB 3rd Quarter TAXABLE Sales Ten Year Change by INDUSTRY - 1995 v. 2005 - in \$

	10 Year Change			
	1995	2005	Percentage	Numerical
AFF	1,163,636	2,189,268	88.1%	1,025,632
Min	1,210,324	1,081,489	-10.6%	-128,835
Const	2,662,302	3,089,078	16.0%	426,776
Manu	3,035,702	3,749,670	23.5%	713,968
TCPU	16,660,836	22,873,141	37.3%	6,212,305
Whole	6,069,710	7,525,987	24.0%	1,456,277
Retail	101,315,641	161,144,513	59.1%	59,828,872
FIRE	5,250,137	6,717,372	27.9%	1,467,235
Service	43,666,117	71,032,302	62.7%	27,366,185
Govt	2,025	11,907	488.0%	9,882
Total	181,036,430	279,414,727	54.3%	98,378,297

Table 1.5

KPB 3rd Quarter TAXABLE Sales by INDUSTRY - 2003, 2004, 2005

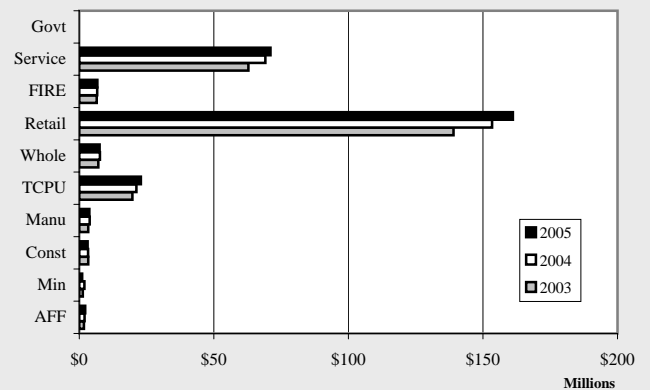

Chart 1.5

KPB 3rd Quarter TAXABLE Sales One Year Change by INDUSTRY - 2004 v. 2005 - in \$

	1 Year Change			
	2004	2005	Percentage	Numerical
AFF	1,979,566	2,189,268	10.6%	209,702
Min	1,908,215	1,081,489	-43.3%	-826,726
Const	3,278,174	3,089,078	-5.8%	-189,096
Manu	3,843,780	3,749,670	-2.4%	-94,110
TCPU	21,221,357	22,873,141	7.8%	1,651,784
Whole	7,644,161	7,525,987	-1.5%	-118,174
Retail	153,382,551	161,144,513	5.1%	7,761,962
FIRE	6,668,226	6,717,372	0.7%	49,146
Service	69,142,137	71,032,302	2.7%	1,890,165
Govt	9,184	11,907	29.6%	2,723
Total	269,077,351	279,414,727	3.8%	10,337,376

Table 1.6

KPB 3rd Quarter TAXABLE Sales Percent by INDUSTRY - 2005

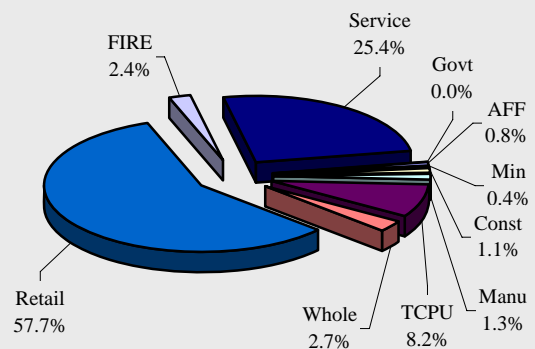

Chart 1.6

KPB Sales

KPB 3rd Quarter GROSS Sales by AREA - 1999-2005 - in \$								
	1999	2000	2001	2002	2003	2004	2005	Annual Change
Homer	66,353,121	70,009,668	77,453,956	89,690,601	87,203,992	93,935,395	99,774,615	6.2%
Kenai	91,880,728	89,505,566	94,911,501	82,601,639	81,240,276	97,858,795	111,294,018	13.7%
Seldovia	1,707,186	1,693,636	1,957,554	1,694,174	2,833,785	1,809,067	2,233,774	23.5%
Seward	50,509,645	57,260,079	62,873,649	56,721,649	61,707,771	63,926,605	66,446,710	3.9%
Soldotna	87,704,206	89,530,301	95,670,432	103,624,839	106,266,939	107,192,921	113,083,093	5.5%
Other KPB	232,722,008	225,474,396	286,388,798	262,740,841	283,926,438	326,600,944	320,091,065	-2.0%
Total	530,876,894	533,473,646	619,255,890	597,073,743	623,179,201	691,323,727	712,923,275	3.1%
Annual Change		0.5%	16.1%	-3.6%	4.4%	10.9%	3.1%	

Table 1.7

KPB 3rd Quarter GROSS Sales Ten Year Change by AREA - 1995 v. 2005 - in \$				
			10 Year Change	
	1995	2005	Percentage	Numerical
Homer	66,559,556	99,774,615	49.9%	33,215,059
Kenai	103,898,722	111,294,018	7.1%	7,395,296
Seldovia	1,869,108	2,233,774	19.5%	364,666
Seward	49,705,098	66,446,710	33.7%	16,741,612
Soldotna	64,724,383	113,083,093	74.7%	48,358,710
Other KPB	233,045,872	320,091,065	37.4%	87,045,193
Total	519,802,739	712,923,275	37.2%	193,120,536

Table 1.8

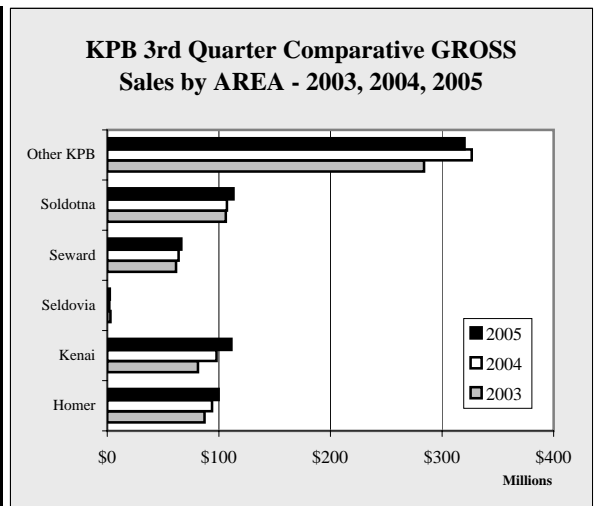

Chart 1.7

KPB 3rd Quarter GROSS Sales One Year Change by AREA - 2004 v. 2005 - in \$				
			1 Year Change	
	2004	2005	Percentage	Numerical
Homer	93,935,395	99,774,615	6.2%	5,839,220
Kenai	97,858,795	111,294,018	13.7%	13,435,223
Seldovia	1,809,067	2,233,774	23.5%	424,707
Seward	63,926,605	66,446,710	3.9%	2,520,105
Soldotna	107,192,921	113,083,093	5.5%	5,890,172
Other KPB	326,600,944	320,091,065	-2.0%	-6,509,879
Total	691,323,727	712,923,275	3.1%	21,599,548

Table 1.9

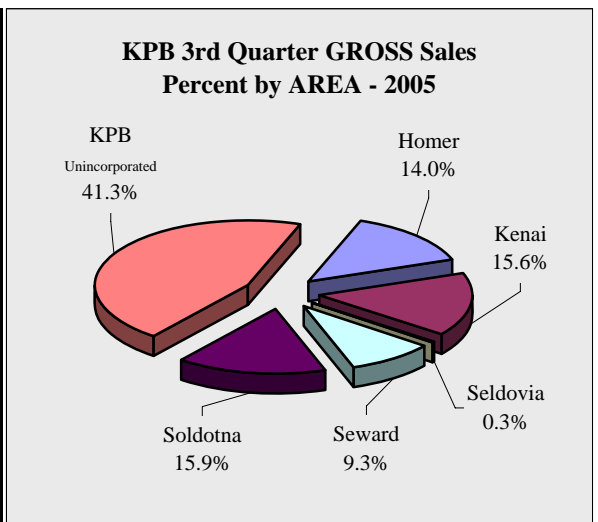

Chart 1.8

KPB Sales

KPB 3rd Quarter TAXABLE Sales by AREA - 1999-2005 - in \$								
	1999	2000	2001	2002	2003	2004	2005	Annual Change
Homer	34,247,729	35,677,211	37,574,702	43,251,111	45,104,233	49,027,379	49,872,039	1.7%
Kenai	34,560,194	36,634,363	38,162,815	38,192,980	31,362,238	40,041,325	42,640,243	6.5%
Seldovia	1,144,627	1,241,108	1,207,525	1,191,989	1,140,319	1,182,138	1,199,541	1.5%
Seward	31,789,068	32,903,473	33,591,333	34,338,060	34,702,382	37,077,424	38,375,511	3.5%
Soldotna	50,500,561	50,523,183	54,143,248	57,488,623	62,578,771	66,177,951	69,580,021	5.1%
Other KPB	61,313,334	66,472,925	68,857,364	69,019,232	69,994,220	75,571,134	77,747,372	2.9%
Total	213,555,513	223,452,263	233,536,987	243,481,995	244,882,163	269,077,351	279,414,727	3.8%
Annual Change		4.6%	4.5%	4.3%	0.6%	9.9%	3.8%	

Table 1.10

KPB 3rd Quarter TAXABLE Sales Ten Year Change by AREA - 1995 v. 2005 - in \$				
	1995	2005	10 Year Change	
			Percentage	Numerical
Homer	30,398,162	49,872,039	64.1%	19,473,877
Kenai	32,455,065	42,640,243	31.4%	10,185,178
Seldovia	1,306,693	1,199,541	-8.2%	-107,152
Seward	22,899,202	38,375,511	67.6%	15,476,309
Soldotna	41,181,901	69,580,021	69.0%	28,398,120
Other KPB	52,795,407	77,747,372	47.3%	24,951,965
Total	181,036,430	279,414,727	54.3%	98,378,297

Table 1.11

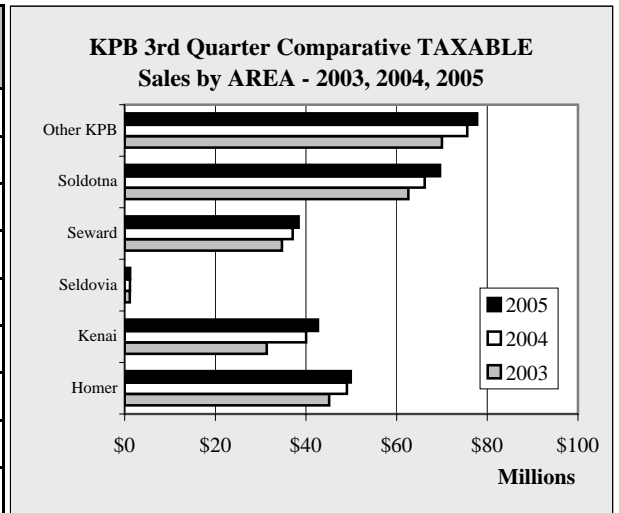

Chart 1.9

KPB 3rd Quarter TAXABLE Sales One Year Change by AREA - 2004 v. 2005 - in \$				
	2004	2005	1 Year Change	
			Percentage	Numerical
Homer	49,027,379	49,872,039	1.7%	844,660
Kenai	40,041,325	42,640,243	6.5%	2,598,918
Seldovia	1,182,138	1,199,541	1.5%	17,403
Seward	37,077,424	38,375,511	3.5%	1,298,087
Soldotna	66,177,951	69,580,021	5.1%	3,402,070
Other KPB	75,571,134	77,747,372	2.9%	2,176,238
Total	269,077,351	279,414,727	3.8%	10,337,376

Table 1.12

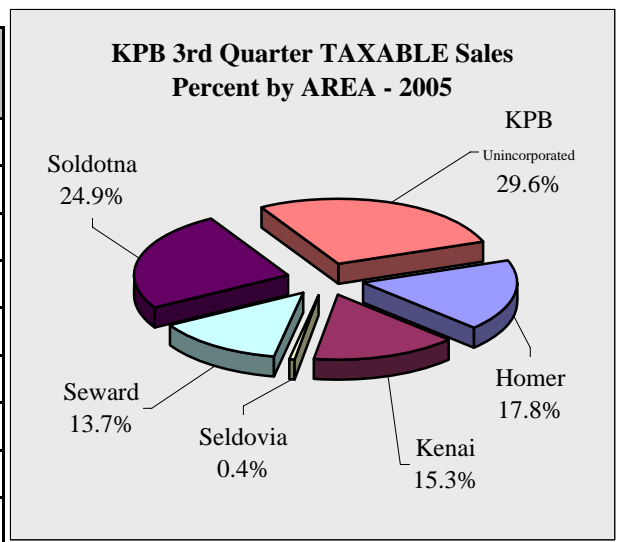

Chart 1.10

KPB Sales

KPB YTD 9/30 GROSS Sales by INDUSTRY - 1999-2005 - in \$

	1999	2000	2001	2002	2003	2004	2005	Annual Change
AFF	29,932,359	23,411,329	15,641,237	14,697,049	19,556,802	21,946,975	26,928,513	22.7%
Min	82,835,844	83,451,127	90,068,349	90,840,113	74,710,807	110,900,498	121,060,842	9.2%
Const	116,222,435	131,753,682	178,005,118	165,114,682	192,884,436	137,967,460	186,900,985	35.5%
Manu	124,440,056	93,340,549	170,252,210	122,774,068	139,052,552	138,854,463	192,260,878	38.5%
TCPU	125,754,388	117,071,511	129,692,291	134,559,094	120,878,237	142,690,707	182,545,476	27.9%
Whole	117,814,212	133,701,371	136,272,759	140,813,502	147,629,417	147,778,990	116,443,305	-21.2%
Retail	415,531,893	438,091,014	478,343,801	479,605,517	495,623,734	538,970,145	565,833,444	5.0%
FIRE	40,343,965	37,875,157	40,808,890	42,379,364	43,294,029	44,967,006	46,903,113	4.3%
Service	181,472,372	192,412,726	208,345,425	230,434,159	227,825,511	245,393,801	254,829,851	3.8%
Govt	25,165	15,103	19,116	18,849	33,191	31,368	35,623	13.6%
Total	1,234,372,689	1,251,123,569	1,447,449,196	1,421,236,397	1,461,488,716	1,529,501,413	1,693,742,030	10.7%
Annual Change		1.4%	15.7%	-1.8%	2.8%	4.7%	10.7%	

Table 1.13

KPB YTD 9/30 GROSS Sales Ten Year Change by INDUSTRY - 1995 v. 2005 - in \$

	10 Year Change			
	1995	2005	Percentage	Numerical
AFF	76,905,363	26,928,513	-65.0%	-49,976,850
Min	68,212,657	121,060,842	77.5%	52,848,185
Const	115,603,700	186,900,985	61.7%	71,297,285
Manu	129,933,142	192,260,878	48.0%	62,327,736
TCPU	172,327,093	182,545,476	5.9%	10,218,383
Whole	94,030,312	116,443,305	23.8%	22,412,993
Retail	329,622,664	565,833,444	71.7%	236,210,780
FIRE	32,041,589	46,903,113	46.4%	14,861,524
Service	143,698,769	254,829,851	77.3%	111,131,082
Govt	8,058	35,623	342.1%	27,565
Total	1,162,383,347	1,693,742,030	45.7%	531,358,683

Table 1.14

KPB YTD 9/30 GROSS Sales by INDUSTRY - 2003, 2004, 2005

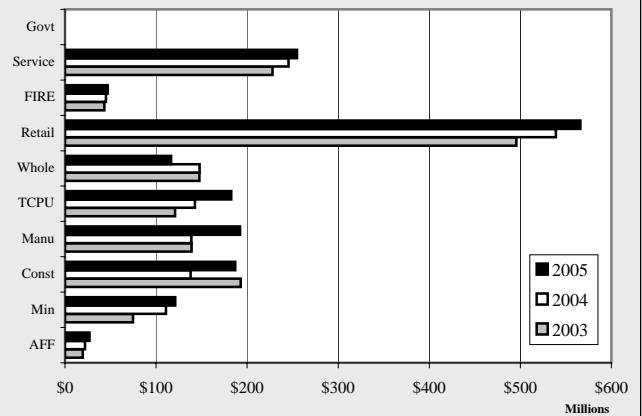

Chart 1.11

KPB YTD 9/30 GROSS Sales One Year Change by INDUSTRY - 2004 v. 2005 - in \$

	1 Year Change			
	2004	2005	Percentage	Numerical
AFF	21,946,975	26,928,513	22.7%	4,981,538
Min	110,900,498	121,060,842	9.2%	10,160,344
Const	137,967,460	186,900,985	35.5%	48,933,525
Manu	138,854,463	192,260,878	38.5%	53,406,415
TCPU	142,690,707	182,545,476	27.9%	39,854,769
Whole	147,778,990	116,443,305	-21.2%	-31,335,685
Retail	538,970,145	565,833,444	5.0%	26,863,299
FIRE	44,967,006	46,903,113	4.3%	1,936,107
Service	245,393,801	254,829,851	3.8%	9,436,050
Govt	31,368	35,623	13.6%	4,255
Total	1,529,501,413	1,693,742,030	10.7%	164,240,617

Table 1.15

KPB YTD 9/30 GROSS Sales Percent by INDUSTRY - 2005

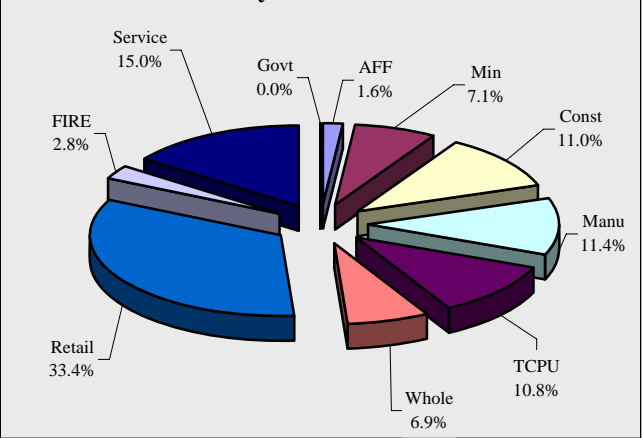

Chart 1.12

KPB Sales

KPB YTD 9/30 TAXABLE Sales by INDUSTRY - 1999-2005 - in \$								
	1999	2000	2001	2002	2003	2004	2005	Annual Change
AFF	2,819,203	3,290,269	3,569,750	3,620,376	4,038,077	4,543,346	4,874,201	7.3%
Min	2,730,828	3,353,218	4,253,804	4,517,435	3,717,982	4,038,387	3,199,393	-20.8%
Const	7,357,411	7,266,334	7,445,322	8,003,659	8,495,455	8,405,301	8,275,278	-1.5%
Manu	7,336,740	7,806,312	7,886,389	7,816,529	7,379,306	8,093,611	7,817,044	-3.4%
TCPU	57,677,741	58,455,005	58,762,803	64,157,165	61,689,992	61,716,824	67,933,763	10.1%
Whole	14,143,083	16,357,422	16,723,746	16,779,106	18,493,784	20,136,979	19,847,684	-1.4%
Retail	279,095,724	291,780,365	313,519,939	322,841,457	331,437,364	358,841,292	377,476,116	5.2%
FIRE	14,585,260	15,404,034	17,615,341	18,448,273	17,824,720	17,383,595	17,230,305	-0.9%
Service	109,801,892	114,374,411	118,074,505	122,937,553	123,144,617	132,838,047	137,115,230	3.2%
Govt	25,165	15,103	19,116	18,849	33,191	31,303	35,623	13.8%
Total	495,573,047	518,102,473	547,870,715	569,140,402	576,254,488	616,028,685	643,804,637	4.5%
Annual Change		4.5%	5.7%	3.9%	1.2%	6.9%	4.5%	

Table 1.16

KPB YTD 9/30 TAXABLE Sales Ten Year Change by INDUSTRY - 1995 v. 2005 - in \$				
	1995	2005	10 Year Change	
			Percentage	Numerical
AFF	2,703,856	4,874,201	80.3%	2,170,345
Min	3,268,443	3,199,393	-2.1%	-69,050
Const	6,363,621	8,275,278	30.0%	1,911,657
Manu	6,713,420	7,817,044	16.4%	1,103,624
TCPU	48,860,495	67,933,763	39.0%	19,073,268
Whole	15,794,077	19,847,684	25.7%	4,053,607
Retail	239,804,942	377,476,116	57.4%	137,671,174
FIRE	14,343,389	17,230,305	20.1%	2,886,916
Service	90,031,804	137,115,230	52.3%	47,083,426
Govt	8,058	35,623	342.1%	27,565
Total	427,892,105	643,804,637	50.5%	215,912,532

Table 1.17

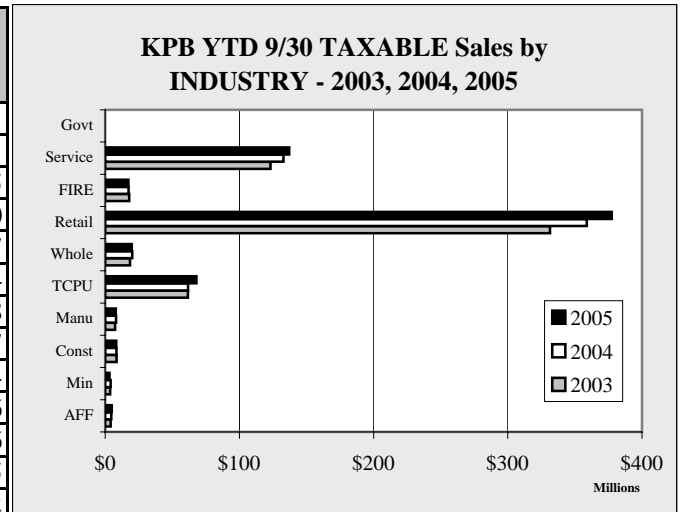

Chart 1.13

KPB YTD 9/30 TAXABLE Sales One Year Change by INDUSTRY - 2004 v. 2005 - in \$				
	2004	2005	1 Year Change	
			Percentage	Numerical
AFF	4,543,346	4,874,201	7.3%	330,855
Min	4,038,387	3,199,393	-20.8%	-838,994
Const	8,405,301	8,275,278	-1.5%	-130,023
Manu	8,093,611	7,817,044	-3.4%	-276,567
TCPU	61,716,824	67,933,763	10.1%	6,216,939
Whole	20,136,979	19,847,684	-1.4%	-289,295
Retail	358,841,292	377,476,116	5.2%	18,634,824
FIRE	17,383,595	17,230,305	-0.9%	-153,290
Service	132,838,047	137,115,230	3.2%	4,277,183
Govt	31,303	35,623	13.8%	4,320
Total	616,028,685	643,804,637	4.5%	27,775,952

Table 1.18

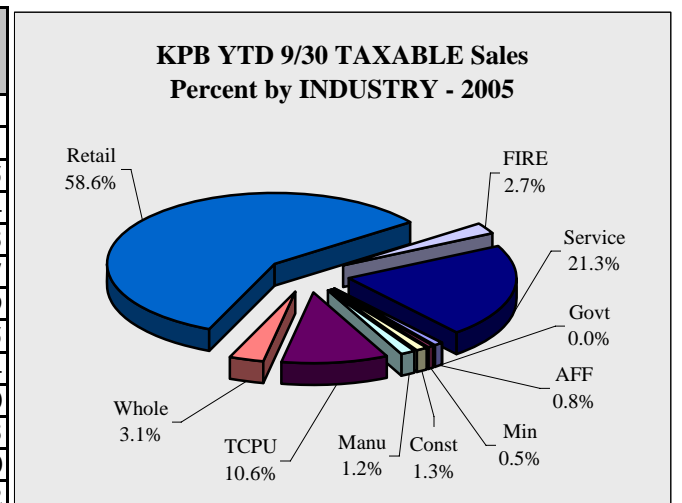

Chart 1.14

KPB Sales

KPB YTD 9/30 GROSS Sales by AREA - 1999-2005 - in \$

	1999	2000	2001	2002	2003	2004	2005	Annual Change
Homer	159,777,957	167,752,417	175,156,409	202,627,292	213,720,212	217,829,195	237,823,817	9.2%
Kenai	202,795,789	211,273,705	234,003,723	211,127,299	210,825,932	239,329,161	288,274,479	20.5%
Seldovia	4,003,432	4,371,228	4,329,670	3,860,941	5,310,245	5,185,784	5,615,390	8.3%
Seward	109,907,857	114,361,913	127,857,199	120,061,038	129,627,108	127,862,694	151,328,540	18.4%
Soldotna	207,009,128	217,247,412	231,515,220	245,718,237	255,743,117	266,429,890	266,654,393	0.1%
Other KPB	550,878,526	536,116,894	674,586,975	637,841,590	646,262,102	672,864,689	744,045,411	10.6%
Total	1,234,372,689	1,251,123,569	1,447,449,196	1,421,236,397	1,461,488,716	1,529,501,413	1,693,742,030	10.7%
Annual Change		1.4%	15.7%	-1.8%	2.8%	4.7%	10.7%	

Table 1.19

**KPB YTD 9/30 GROSS Sales Ten Year Change
by AREA - 1995 v. 2005 - in \$**

	10 Year Change			
	1995	2005	Percentage	Numerical
Homer	146,846,008	237,823,817	62.0%	90,977,809
Kenai	214,123,745	288,274,479	34.6%	74,150,734
Seldovia	4,634,581	5,615,390	21.2%	980,809
Seward	98,754,048	151,328,540	53.2%	52,574,492
Soldotna	158,714,935	266,654,393	68.0%	107,939,458
Other KPB	539,310,030	744,045,411	38.0%	204,735,381
Total	1,162,383,347	1,693,742,030	45.7%	531,358,683

Table 1.20

**KPB YTD 9/30 Comparative GROSS Sales
by AREA - 2003, 2004, 2005**

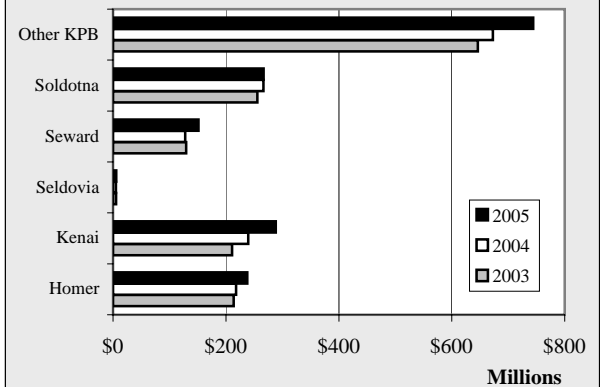

Chart 1.15

**KPB YTD 9/30 GROSS Sales One Year Change
by AREA - 2004 v. 2005 - in \$**

	1 Year Change			
	2004	2005	Percentage	Numerical
Homer	217,829,195	237,823,817	9.2%	19,994,622
Kenai	239,329,161	288,274,479	20.5%	48,945,318
Seldovia	5,185,784	5,615,390	8.3%	429,606
Seward	127,862,694	151,328,540	18.4%	23,465,846
Soldotna	266,429,890	266,654,393	0.1%	224,503
Other KPB	672,864,689	744,045,411	10.6%	71,180,722
Total	1,529,501,413	1,693,742,030	10.7%	164,240,617

Table 1.21

**KPB YTD 9/30 GROSS Sales
Percent by AREA - 2005**

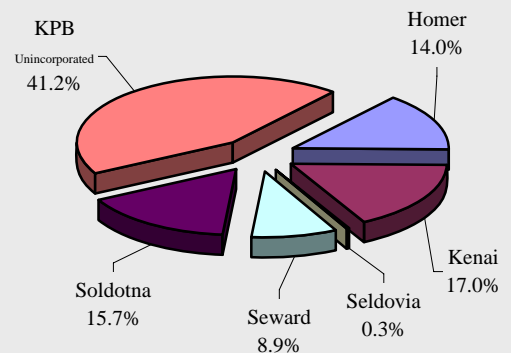

Chart 1.16

KPB Sales

KPB YTD 9/30 TAXABLE Sales by AREA - 1999-2005 - in \$								
	1999	2000	2001	2002	2003	2004	2005	Annual Change
Homer	77,824,755	81,802,943	85,531,383	96,215,704	104,598,983	112,500,823	115,662,725	2.8%
Kenai	90,649,276	93,703,781	101,040,725	101,780,887	92,278,268	105,860,974	109,555,176	3.5%
Seldovia	2,630,027	2,828,456	2,747,113	2,664,443	2,702,255	2,688,453	2,704,214	0.6%
Seward	60,914,932	63,438,731	64,218,090	65,565,578	66,058,967	69,569,233	73,796,694	6.1%
Soldotna	117,145,729	118,954,219	129,549,699	134,729,165	144,062,542	152,572,208	160,455,467	5.2%
Other KPB	146,408,328	157,374,343	164,783,705	168,184,625	166,553,473	172,836,994	181,630,361	5.1%
Total	495,573,047	518,102,473	547,870,715	569,140,402	576,254,488	616,028,685	643,804,637	4.5%
Annual Change		4.5%	5.7%	3.9%	1.2%	6.9%	4.5%	

Table 1.22

KPB YTD 9/30 TAXABLE Sales Ten Year Change by AREA - 1995-2005 - in \$				
	10 Year Change			
	1995	2005	Percentage	Numerical
Homer	70,096,768	115,662,725	65.0%	45,565,957
Kenai	83,600,496	109,555,176	31.0%	25,954,680
Seldovia	2,891,320	2,704,214	-6.5%	-187,106
Seward	47,295,117	73,796,694	56.0%	26,501,577
Soldotna	96,920,379	160,455,467	65.6%	63,535,088
Other KPB	127,088,025	181,630,361	42.9%	54,542,336
Total	427,892,105	643,804,637	50.5%	215,912,532

Table 1.23

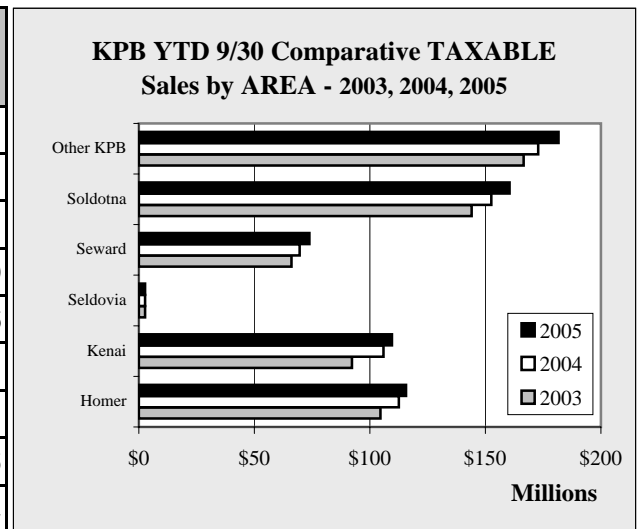

Chart 1.17

KPB YTD 9/30 TAXABLE Sales One Year Change by AREA - 2004 v. 2005 - in \$				
	1 Year Change			
	2004	2005	Percentage	Numerical
Homer	112,500,823	115,662,725	2.8%	3,161,902
Kenai	105,860,974	109,555,176	3.5%	3,694,202
Seldovia	2,688,453	2,704,214	0.6%	15,761
Seward	69,569,233	73,796,694	6.1%	4,227,461
Soldotna	152,572,208	160,455,467	5.2%	7,883,259
Other KPB	172,836,994	181,630,361	5.1%	8,793,367
Total	616,028,685	643,804,637	4.5%	27,775,952

Table 1.24

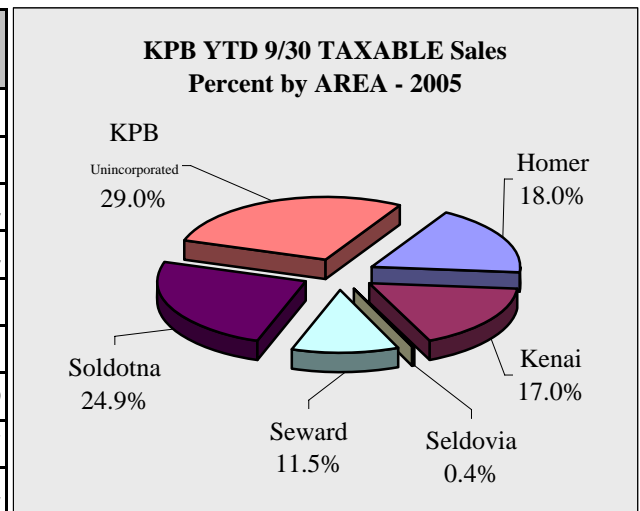

Chart 1.18

KPB Sales

KPB Annual GROSS Sales by INDUSTRY - 1998-2004 - in \$								
	1998	1999	2000	2001	2002	2003	2004	Annual Change
AFF	30,373,442	32,347,943	24,816,872	17,584,763	16,750,059	22,009,310	27,631,235	25.5%
Min	190,689,442	115,241,075	121,868,065	126,250,792	113,521,181	106,561,739	165,354,111	55.2%
Const	187,102,648	166,008,223	185,994,582	241,706,588	229,399,098	258,251,958	237,336,814	-8.1%
Manu	147,360,433	165,066,528	117,856,947	287,725,053	201,047,383	199,442,339	170,708,461	-14.4%
TCPU	159,766,641	169,321,042	156,272,089	173,246,581	172,554,610	158,372,166	193,924,248	22.4%
Whole	149,117,372	155,121,630	171,235,874	177,036,125	188,223,387	194,212,922	366,603,918	88.8%
Retail	547,202,550	545,752,691	580,370,933	633,597,773	625,008,358	644,637,228	699,837,432	8.6%
FIRE	50,782,517	51,186,806	50,390,903	54,153,772	54,924,793	58,320,708	64,665,993	10.9%
Service	211,144,805	220,251,298	235,820,173	256,185,223	276,510,185	279,281,223	310,768,193	11.3%
Govt	26,751	28,814	17,350	20,316	22,579	41,980	35,105	-16.4%
Total	1,673,566,601	1,620,326,050	1,644,643,788	1,967,506,986	1,877,961,633	1,921,131,573	2,236,865,510	16.4%
Annual Change		-3.2%	1.5%	19.6%	-4.6%	2.3%	16.4%	

Table 1.25

KPB Annual GROSS Sales Ten Year Change by INDUSTRY - 1994-2004 - in \$				
	1994	2004	10 Year Change	
			Percentage	Numerical
AFF	55,520,292	27,631,235	-50.2%	-27,889,057
Min	124,428,885	165,354,111	32.9%	40,925,226
Const	144,672,165	237,336,814	64.1%	92,664,649
Manu	125,684,092	170,708,461	35.8%	45,024,369
TCPU	216,882,266	193,924,248	-10.6%	-22,958,018
Whole	88,960,238	366,603,918	312.1%	277,643,680
Retail	406,692,795	699,837,432	72.1%	293,144,637
FIRE	55,375,125	64,665,993	16.8%	9,290,868
Service	165,995,597	310,768,193	87.2%	144,772,596
Govt	10,251	35,105	242.5%	24,854
Total	1,384,221,706	2,236,865,510	61.6%	852,643,804

Table 1.26

KPB Annual GROSS Sales One Year Change by INDUSTRY - 2003 v. 2004 - in \$				
	2003	2004	1 Year Change	
			Percentage	Numerical
AFF	22,009,310	27,631,235	25.5%	5,621,925
Min	106,561,739	165,354,111	55.2%	58,792,372
Const	258,251,958	237,336,814	-8.1%	-20,915,144
Manu	199,442,339	170,708,461	-14.4%	-28,733,878
TCPU	158,372,166	193,924,248	22.4%	35,552,082
Whole	194,212,922	366,603,918	88.8%	172,390,996
Retail	644,637,228	699,837,432	8.6%	55,200,204
FIRE	58,320,708	64,665,993	10.9%	6,345,285
Service	279,281,223	310,768,193	11.3%	31,486,970
Govt	41,980	35,105	-16.4%	-6,875
Total	1,921,131,573	2,236,865,510	16.4%	315,733,937

Table 1.27

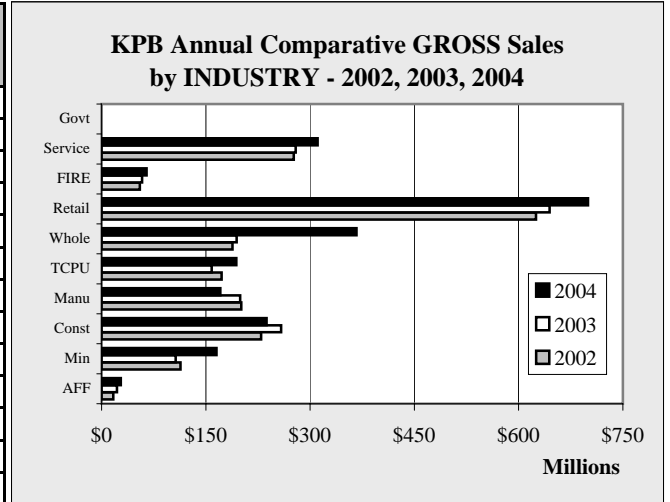

Chart 1.19

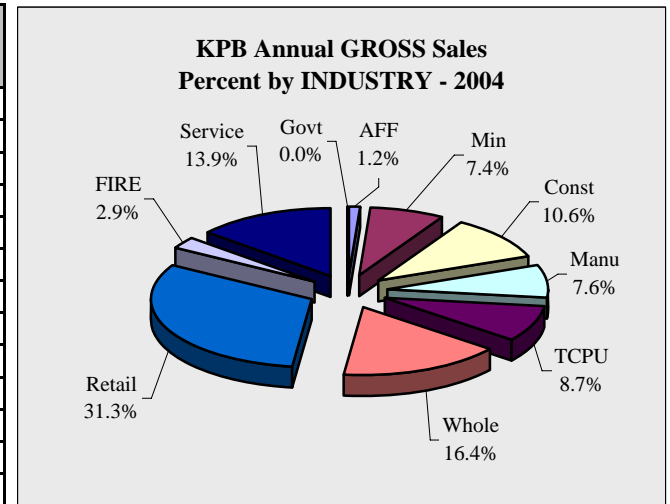

Chart 1.20

KPB Sales

KPB Annual TAXABLE Sales by INDUSTRY - 1998-2004 - in \$								
	1998	1999	2000	2001	2002	2003	2004	Annual Change
AFF	3,458,989	3,539,802	4,148,862	4,391,790	4,461,252	5,010,961	5,525,243	10.3%
Min	5,202,698	3,828,650	4,613,878	5,863,223	5,848,904	4,885,262	5,502,300	12.6%
Const	9,821,330	9,921,434	9,658,671	10,002,648	10,709,485	11,258,243	11,243,037	-0.1%
Manu	9,578,020	9,251,298	9,792,611	9,654,663	9,616,559	9,239,486	9,859,946	6.7%
TCPU	72,108,745	79,282,344	77,420,153	79,415,747	83,947,088	81,373,510	82,707,524	1.6%
Whole	18,357,305	19,290,256	21,493,691	22,282,063	21,690,782	24,282,313	26,290,768	8.3%
Retail	353,131,302	367,123,730	383,777,809	411,721,005	419,549,532	429,206,254	461,629,346	7.6%
FIRE	18,576,711	18,862,816	20,702,551	23,486,072	24,084,827	22,890,777	22,549,786	-1.5%
Service	122,225,757	129,434,976	135,510,623	139,066,219	144,301,953	144,812,350	154,952,698	7.0%
Govt	26,744	28,814	17,350	20,316	22,579	41,980	35,040	-16.5%
Total	612,487,601	640,564,120	667,136,199	705,903,746	724,232,961	733,001,136	780,295,688	6.5%
Annual Change		4.6%	4.1%	5.8%	2.6%	1.2%	6.5%	

Table 1.28

KPB Annual TAXABLE Sales Ten Year Change by INDUSTRY - 1994 v. 2004 - in \$				
			10 Year Change	
	1994	2004	Percentage	Numerical
AFF	3,454,687	5,525,243	59.9%	2,070,556
Min	6,132,287	5,502,300	-10.3%	-629,987
Const	8,077,694	11,243,037	39.2%	3,165,343
Manu	7,808,695	9,859,946	26.3%	2,051,251
TCPU	64,017,267	82,707,524	29.2%	18,690,257
Whole	19,542,465	26,290,768	34.5%	6,748,303
Retail	299,416,591	461,629,346	54.2%	162,212,755
FIRE	18,378,264	22,549,786	22.7%	4,171,522
Service	100,262,803	154,952,698	54.5%	54,689,895
Govt	10,251	35,040	241.8%	24,789
Total	527,101,004	780,295,688	48.0%	253,194,684

Table 1.29

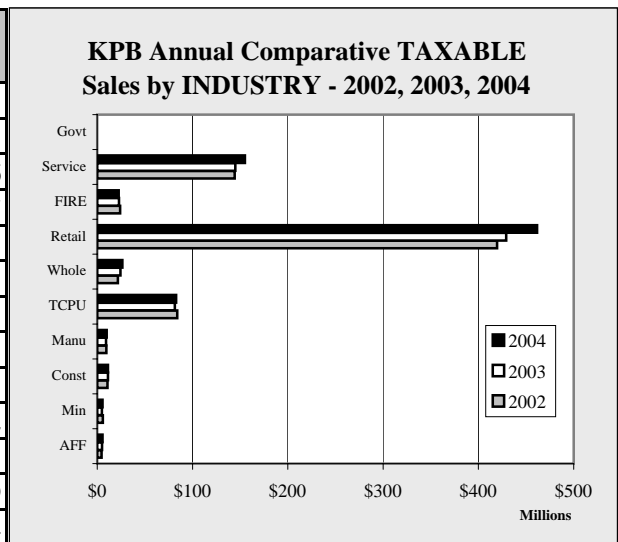

Chart 1.21

KPB Annual TAXABLE Sales One Year Change by INDUSTRY - 2003 v. 2004 - in \$				
			1 Year Change	
	2003	2004	Percentage	Numerical
AFF	5,010,961	5,525,243	10.3%	514,282
Min	4,885,262	5,502,300	12.6%	617,038
Const	11,258,243	11,243,037	-0.1%	-15,206
Manu	9,239,486	9,859,946	6.7%	620,460
TCPU	81,373,510	82,707,524	1.6%	1,334,014
Whole	24,282,313	26,290,768	8.3%	2,008,455
Retail	429,206,254	461,629,346	7.6%	32,423,092
FIRE	22,890,777	22,549,786	-1.5%	-340,991
Service	144,812,350	154,952,698	7.0%	10,140,348
Govt	41,980	35,040	-16.5%	-6,940
Total	733,001,136	780,295,688	6.5%	47,294,552

Table 1.30

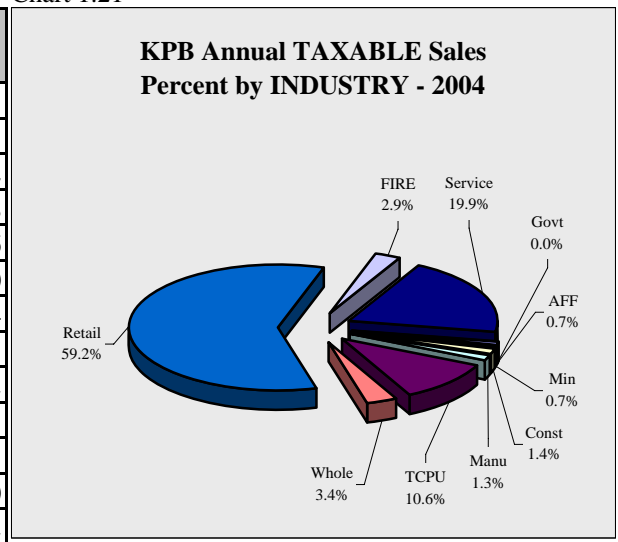

Chart 1.22

KPB Sales

KPB Annual GROSS Sales by AREA - 1998-2004 - in \$								
	1998	1999	2000	2001	2002	2003	2004	Annual Change
Homer	212,442,617	203,842,475	215,981,724	229,703,507	263,195,800	274,049,116	290,454,399	6.0%
Kenai	280,079,940	270,746,118	283,682,464	310,426,425	279,745,403	283,414,662	475,463,260	67.8%
Seldovia	4,723,739	4,844,770	5,267,325	5,249,471	4,817,877	7,259,554	8,329,831	14.7%
Seward	132,506,248	130,155,521	142,152,279	148,360,553	142,367,126	156,961,522	166,223,670	5.9%
Soldotna	250,793,664	277,588,737	289,255,311	309,118,231	325,899,019	337,898,235	361,243,013	6.9%
Other KPB	793,020,393	733,148,429	708,304,685	964,648,799	861,936,408	861,548,484	935,151,337	8.5%
Total	1,673,566,601	1,620,326,050	1,644,643,788	1,967,506,986	1,877,961,633	1,921,131,573	2,236,865,510	16.4%
Annual Change		-3.2%	1.5%	19.6%	-4.6%	2.3%	16.4%	

Table 1.31

KPB Annual GROSS Sales Ten Year Change by AREA - 1994 v. 2004 - in \$				
	10 Year Change			
	1994	2004	Percentage	Numerical
Homer	171,092,369	290,454,399	69.8%	119,362,030
Kenai	249,216,590	475,463,260	90.8%	226,246,670
Seldovia	5,275,307	8,329,831	57.9%	3,054,524
Seward	99,875,014	166,223,670	66.4%	66,348,656
Soldotna	194,609,544	361,243,013	85.6%	166,633,469
Other KPB	664,152,882	935,151,337	40.8%	270,998,455
Total	1,384,221,706	2,236,865,510	61.6%	852,643,804

Table 1.32

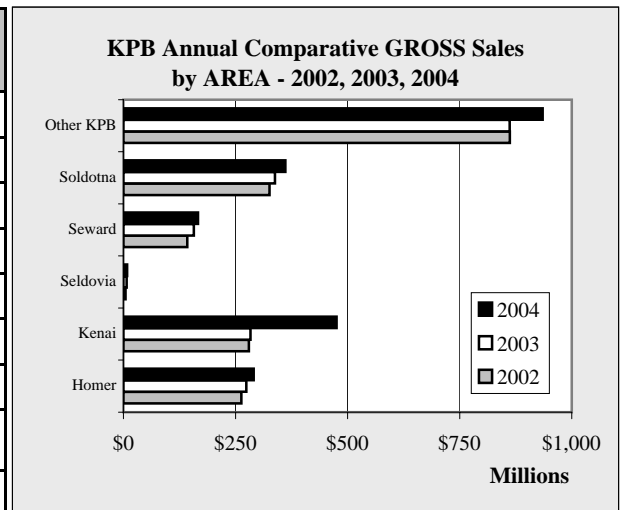

Chart 1.23

KPB Annual GROSS Sales One Year Change by AREA - 2003-2004 - in \$				
	1 Year Change			
	2003	2004	Percentage	Numerical
Homer	274,049,116	290,454,399	6.0%	16,405,283
Kenai	283,414,662	475,463,260	67.8%	192,048,598
Seldovia	7,259,554	8,329,831	14.7%	1,070,277
Seward	156,961,522	166,223,670	5.9%	9,262,148
Soldotna	337,898,235	361,243,013	6.9%	23,344,778
Other KPB	861,548,484	935,151,337	8.5%	73,602,853
Total	1,921,131,573	2,236,865,510	16.4%	315,733,937

Table 1.33

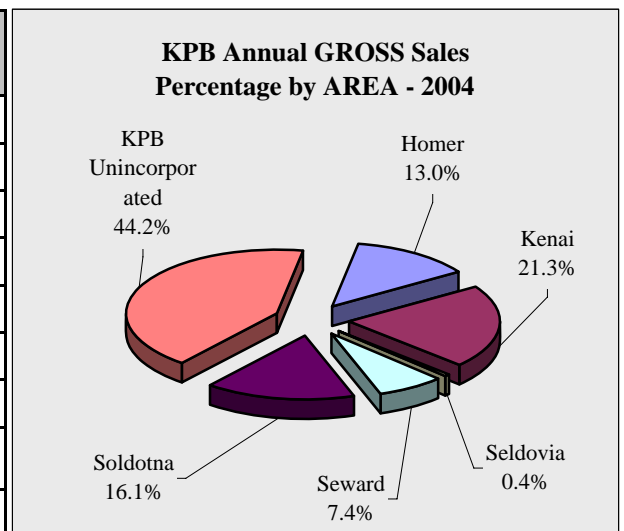

Chart 1.24

KPB Sales

KPB Annual TAXABLE Sales by AREA - 1998-2004 - in \$								
	1998	1999	2000	2001	2002	2003	2004	Annual Change
Homer	94,441,342	98,148,738	103,190,116	107,311,539	121,268,118	131,704,530	139,999,037	6.3%
Kenai	120,030,707	124,367,091	127,766,126	137,043,924	136,769,610	121,354,719	138,672,979	14.3%
Seldovia	3,398,293	3,229,249	3,418,123	3,359,279	3,272,389	3,376,944	3,386,312	0.3%
Seward	67,278,264	71,472,199	73,983,426	74,225,591	75,598,696	76,348,269	79,955,659	4.7%
Soldotna	147,789,661	155,952,764	159,436,128	172,418,438	176,977,868	190,620,882	200,044,811	4.9%
Other KPB	179,549,334	187,394,079	199,342,280	211,544,975	210,346,280	209,595,792	218,236,890	4.1%
Total	612,487,601	640,564,120	667,136,199	705,903,746	724,232,961	733,001,136	780,295,688	6.5%
Annual Change		4.6%	4.1%	5.8%	2.6%	1.2%	6.5%	

Table 1.34

KPB Annual TAXABLE Sales Ten Year Change by AREA - 1994 v. 2004 - in \$				
	10 Year Change			
	1994	2004	Percentage	Numerical
Homer	84,045,458	139,999,037	66.6%	55,953,579
Kenai	114,402,035	138,672,979	21.2%	24,270,944
Seldovia	3,117,185	3,386,312	8.6%	269,127
Seward	53,259,177	79,955,659	50.1%	26,696,482
Soldotna	119,702,481	200,044,811	67.1%	80,342,330
Other KPB	152,574,668	218,236,890	43.0%	65,662,222
Total	527,101,004	780,295,688	48.0%	253,194,684

Table 1.35

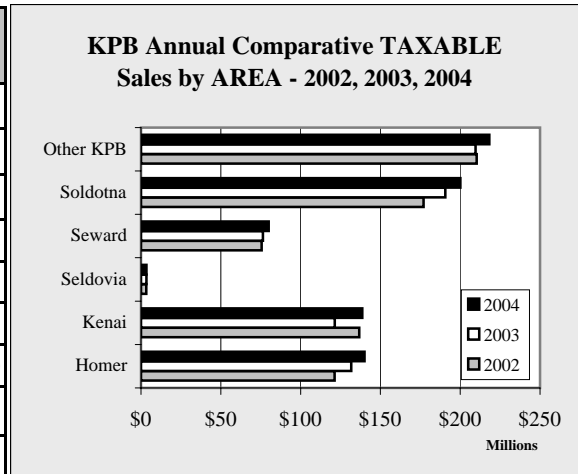

Chart 1.25

KPB Annual TAXABLE Sales One Year Change by AREA - 2003 v. 2004 - in \$				
	1 Year Change			
	2003	2004	Percentage	Numerical
Homer	131,704,530	139,999,037	6.3%	8,294,507
Kenai	121,354,719	138,672,979	14.3%	17,318,260
Seldovia	3,376,944	3,386,312	0.3%	9,368
Seward	76,348,269	79,955,659	4.7%	3,607,390
Soldotna	190,620,882	200,044,811	4.9%	9,423,929
Other KPB	209,595,792	218,236,890	4.1%	8,641,098
Total	733,001,136	780,295,688	6.5%	47,294,552

Table 1.36

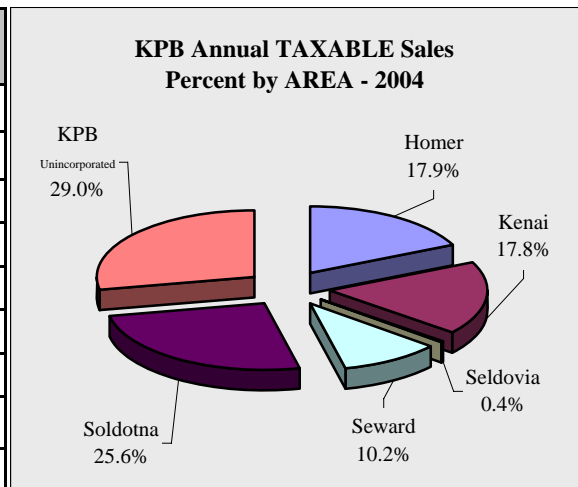

Chart 1.26

KPB Sales

KPB Annual GROSS Sales by INDUSTRY by Quarter - 2002-2005 - in \$					
	1st Quarter	2nd Quarter	3rd Quarter	4th Quarter	Total
2002					
AFF	2,004,841	2,856,503	9,835,705	2,053,010	16,750,059
Min	34,662,385	29,861,507	26,316,221	22,681,068	113,521,181
Const	43,149,133	49,852,546	72,113,003	64,284,416	229,399,098
Manu	21,341,761	44,663,448	56,768,859	78,273,315	201,047,383
TCPU	40,723,392	42,378,179	51,457,523	37,995,516	172,554,610
Whole	37,128,746	46,538,996	57,145,760	47,409,885	188,223,387
Retail	115,899,097	165,285,986	198,420,434	145,402,841	625,008,358
FIRE	12,389,238	14,756,677	15,233,449	12,545,429	54,924,793
Service	43,234,458	77,421,202	109,778,499	46,076,026	276,510,185
Govt	6,700	7,859	4,290	3,730	22,579
Total	350,539,751	473,622,903	597,073,743	456,725,236	1,877,961,633
2003					
AFF	2,019,939	4,045,723	13,491,140	2,452,508	22,009,310
Min	19,260,142	25,083,685	30,366,980	31,850,932	106,561,739
Const	43,286,848	67,679,718	81,917,870	65,367,522	258,251,958
Manu	38,576,448	34,259,747	66,216,357	60,389,787	199,442,339
TCPU	38,217,073	38,841,966	43,819,198	37,493,929	158,372,166
Whole	35,918,425	50,841,751	60,869,241	46,583,505	194,212,922
Retail	123,115,445	170,701,632	201,806,657	149,013,494	644,637,228
FIRE	11,797,457	15,377,000	16,119,572	15,026,679	58,320,708
Service	41,577,775	77,687,742	108,559,994	51,455,712	279,281,223
Govt	12,319	8,680	12,192	8,789	41,980
Total	353,781,871	484,527,644	623,179,201	459,642,857	1,921,131,573
2004					
AFF	2,340,926	3,911,032	15,695,017	5,684,260	27,631,235
Min	39,801,394	32,098,347	39,000,757	54,453,613	165,354,111
Const	28,598,260	42,316,016	67,053,184	99,369,354	237,336,814
Manu	26,107,055	15,540,229	97,207,179	31,853,998	170,708,461
TCPU	38,967,049	48,291,198	55,432,460	51,233,541	193,924,248
Whole	41,782,771	50,630,515	55,365,704	218,824,928	366,603,918
Retail	126,806,114	187,668,631	224,495,400	160,867,287	699,837,432
FIRE	13,390,042	14,525,303	17,051,661	19,698,987	64,665,993
Service	43,096,322	82,284,298	120,013,181	65,374,392	310,768,193
Govt	13,663	8,521	9,184	3,737	35,105
Total	360,903,596	477,274,090	691,323,727	707,364,097	2,236,865,510
2005					
					Year To Date
AFF	2,974,036	5,742,115	18,212,362		26,928,513
Min	39,831,609	35,586,431	45,642,802		121,060,842
Const	42,289,400	69,803,788	74,807,797		186,900,985
Manu	34,011,661	58,260,048	99,989,169		192,260,878
TCPU	58,382,859	68,591,583	55,571,034		182,545,476
Whole	37,234,787	36,413,842	42,794,676		116,443,305
Retail	131,203,016	200,110,721	234,519,707		565,833,444
FIRE	11,946,348	16,572,214	18,384,551		46,903,113
Service	46,134,713	85,705,868	122,989,270		254,829,851
Govt	15,214	8,502	11,907		35,623
Total	404,023,643	576,795,112	712,923,275		1,693,742,030

Table 1.37

KPB Sales

KPB Annual TAXABLE Sales by INDUSTRY by Quarter - 2002-2005 - in \$					
	1st Quarter	2nd Quarter	3rd Quarter	4th Quarter	Total
2002					
AFF	796,380	1,423,988	1,400,008	840,876	4,461,252
Min	1,482,601	1,484,251	1,550,583	1,331,469	5,848,904
Const	2,037,148	2,677,823	3,288,688	2,705,826	10,709,485
Manu	1,307,744	2,791,765	3,717,020	1,800,030	9,616,559
TCPU	21,573,935	21,477,202	21,106,028	19,789,923	83,947,088
Whole	4,783,261	5,679,123	6,316,722	4,911,676	21,690,782
Retail	76,421,463	109,883,510	136,536,484	96,708,075	419,549,532
FIRE	5,453,086	6,078,006	6,917,181	5,636,554	24,084,827
Service	18,939,288	41,353,274	62,644,991	21,364,400	144,301,953
Govt	6,700	7,859	4,290	3,730	22,579
Total	132,801,606	192,856,801	243,481,995	155,092,559	724,232,961
2003					
AFF	763,045	1,577,278	1,697,754	972,884	5,010,961
Min	1,233,618	1,170,493	1,313,871	1,167,280	4,885,262
Const	2,051,978	3,126,868	3,316,609	2,762,788	11,258,243
Manu	1,438,887	2,607,213	3,333,206	1,860,180	9,239,486
TCPU	21,650,525	20,321,138	19,718,329	19,683,518	81,373,510
Whole	5,052,561	6,337,983	7,103,240	5,788,529	24,282,313
Retail	79,978,199	112,406,985	139,052,180	97,768,890	429,206,254
FIRE	5,334,747	5,999,848	6,490,125	5,066,057	22,890,777
Service	18,779,148	41,520,812	62,844,657	21,667,733	144,812,350
Govt	12,319	8,680	12,192	8,789	41,980
Total	136,295,027	195,077,298	244,882,163	156,746,648	733,001,136
2004					
AFF	889,277	1,674,503	1,979,566	981,897	5,525,243
Min	1,047,668	1,082,504	1,908,215	1,463,913	5,502,300
Const	2,209,429	2,917,698	3,278,174	2,837,736	11,243,037
Manu	1,512,130	2,737,701	3,843,780	1,766,335	9,859,946
TCPU	21,021,541	19,473,926	21,221,357	20,990,700	82,707,524
Whole	5,892,430	6,600,388	7,644,161	6,153,789	26,290,768
Retail	83,126,196	122,332,545	153,382,551	102,788,054	461,629,346
FIRE	4,941,391	5,773,978	6,668,226	5,166,191	22,549,786
Service	19,252,256	44,443,654	69,142,137	22,114,651	154,952,698
Govt	13,598	8,521	9,184	3,737	35,040
Total	139,905,916	207,045,418	269,077,351	164,267,003	780,295,688
2005					
					Year To Date
AFF	947,666	1,737,267	2,189,268		4,874,201
Min	1,087,830	1,030,074	1,081,489		3,199,393
Const	2,075,966	3,110,234	3,089,078		8,275,278
Manu	1,343,696	2,723,678	3,749,670		7,817,044
TCPU	23,073,894	21,986,728	22,873,141		67,933,763
Whole	5,623,554	6,698,143	7,525,987		19,847,684
Retail	85,815,597	130,516,006	161,144,513		377,476,116
FIRE	4,729,047	5,783,886	6,717,372		17,230,305
Service	19,623,102	46,459,826	71,032,302		137,115,230
Govt	15,214	8,502	11,907		35,623
Total	144,335,566	220,054,344	279,414,727		643,804,637

Table 1.38

KPB Sales

KPB Annual GROSS Sales by AREA by Quarter - 2000-2005 - in \$					
	1st Qtr	2nd Qtr	3rd Qtr	4th Qtr	Total
2000					
Homer	38,455,167	59,287,582	70,009,668	48,229,307	215,981,724
Kenai	55,609,576	66,158,563	89,505,566	72,408,759	283,682,464
Seldovia	1,150,692	1,526,900	1,693,636	896,097	5,267,325
Seward	19,087,797	38,014,037	57,260,079	27,790,366	142,152,279
Soldotna	55,201,896	72,515,215	89,530,301	72,007,899	289,255,311
Other KPB	126,664,981	183,977,517	225,474,396	172,187,791	708,304,685
Total	296,170,109	421,479,814	533,473,646	393,520,219	1,644,643,788
2001					
Homer	40,844,978	56,857,475	77,453,956	54,547,098	229,703,507
Kenai	62,418,286	76,673,936	94,911,501	76,422,702	310,426,425
Seldovia	898,811	1,473,305	1,957,554	919,801	5,249,471
Seward	20,531,272	44,452,278	62,873,649	20,503,354	148,360,553
Soldotna	60,802,277	75,042,511	95,670,432	77,603,011	309,118,231
Other KPB	170,550,210	217,647,967	286,388,798	290,061,824	964,648,799
Total	356,045,834	472,147,472	619,255,890	520,057,790	1,967,506,986
2002					
Homer	44,264,946	68,671,745	89,690,601	60,568,508	263,195,800
Kenai	60,596,369	67,929,291	82,601,639	68,618,104	279,745,403
Seldovia	1,011,712	1,155,055	1,694,174	956,936	4,817,877
Seward	22,954,013	40,385,376	56,721,649	22,306,088	142,367,126
Soldotna	62,331,750	79,761,648	103,624,839	80,180,782	325,899,019
Other KPB	159,380,961	215,719,788	262,740,841	224,094,818	861,936,408
Total	350,539,751	473,622,903	597,073,743	456,725,236	1,877,961,633
2003					
Homer	51,228,276	75,287,944	87,203,992	60,328,904	274,049,116
Kenai	62,150,857	67,434,799	81,240,276	72,588,730	283,414,662
Seldovia	847,005	1,629,455	2,833,785	1,949,309	7,259,554
Seward	20,935,184	46,984,153	61,707,771	27,334,414	156,961,522
Soldotna	64,254,952	85,221,226	106,266,939	82,155,118	337,898,235
Other KPB	154,365,597	207,970,067	283,926,438	215,286,382	861,548,484
Total	353,781,871	484,527,644	623,179,201	459,642,857	1,921,131,573
2004					
Homer	48,141,586	75,752,214	93,935,395	72,625,204	290,454,399
Kenai	61,083,004	80,387,362	97,858,795	236,134,099	475,463,260
Seldovia	1,405,047	1,971,670	1,809,067	3,144,047	8,329,831
Seward	21,175,289	42,760,800	63,926,605	38,360,976	166,223,670
Soldotna	69,928,154	89,308,815	107,192,921	94,813,123	361,243,013
Other KPB	159,170,516	187,093,229	326,600,944	262,286,648	935,151,337
Total	360,903,596	477,274,090	691,323,727	707,364,097	2,236,865,510
2005					
					Year to Date
Homer	51,880,635	86,168,567	99,774,615		237,823,817
Kenai	75,542,168	101,438,293	111,294,018		288,274,479
Seldovia	1,261,067	2,120,549	2,233,774		5,615,390
Seward	26,459,285	58,422,545	66,446,710		151,328,540
Soldotna	65,971,798	87,599,502	113,083,093		266,654,393
Other KPB	182,908,690	241,045,656	320,091,065		744,045,411
Total	404,023,643	576,795,112	712,923,275		1,693,742,030

Table 1.39

KPB Sales

KPB Annual TAXABLE Sales by AREA by Quarter - 2000-2005 - in \$					
	1st Qtr	2nd Qtr	3rd Qtr	4th Qtr	Total
2000					
Homer	17,327,860	28,797,872	35,677,211	21,387,173	103,190,116
Kenai	25,521,513	31,547,905	36,634,363	34,062,345	127,766,126
Seldovia	569,093	1,018,255	1,241,108	589,667	3,418,123
Seward	9,374,360	21,160,898	32,903,473	10,544,695	73,983,426
Soldotna	29,664,420	38,766,616	50,523,183	40,481,909	159,436,128
Other KPB	35,696,361	55,205,057	66,472,925	41,967,937	199,342,280
Total	118,153,607	176,496,603	223,452,263	149,033,726	667,136,199
2001					
Homer	17,765,204	30,191,477	37,574,702	21,780,156	107,311,539
Kenai	27,889,241	34,988,669	38,162,815	36,003,199	137,043,924
Seldovia	583,555	956,033	1,207,525	612,166	3,359,279
Seward	9,073,493	21,553,264	33,591,333	10,007,501	74,225,591
Soldotna	32,492,377	42,914,074	54,143,248	42,868,739	172,418,438
Other KPB	38,055,259	57,871,082	68,857,364	46,761,270	211,544,975
Total	125,859,129	188,474,599	233,536,987	158,033,031	705,903,746
2002					
Homer	18,697,104	34,267,489	43,251,111	25,052,414	121,268,118
Kenai	28,938,342	34,649,565	38,192,980	34,988,723	136,769,610
Seldovia	573,624	898,830	1,191,989	607,946	3,272,389
Seward	9,051,044	22,176,474	34,338,060	10,033,118	75,598,696
Soldotna	33,736,608	43,503,934	57,488,623	42,248,703	176,977,868
Other KPB	41,804,884	57,360,509	69,019,232	42,161,655	210,346,280
Total	132,801,606	192,856,801	243,481,995	155,092,559	724,232,961
2003					
Homer	22,456,282	37,038,468	45,104,233	27,105,547	131,704,530
Kenai	31,103,976	29,812,054	31,362,238	29,076,451	121,354,719
Seldovia	598,970	962,966	1,140,319	674,689	3,376,944
Seward	9,284,504	22,072,081	34,702,382	10,289,302	76,348,269
Soldotna	34,464,122	47,019,649	62,578,771	46,558,340	190,620,882
Other KPB	38,387,173	58,172,080	69,994,220	43,042,319	209,595,792
Total	136,295,027	195,077,298	244,882,163	156,746,648	733,001,136
2004					
Homer	23,824,920	39,648,524	49,027,379	27,498,214	139,999,037
Kenai	29,556,491	36,263,158	40,041,325	32,812,005	138,672,979
Seldovia	566,726	939,589	1,182,138	697,859	3,386,312
Seward	9,494,764	22,997,045	37,077,424	10,386,426	79,955,659
Soldotna	37,383,828	49,010,429	66,177,951	47,472,603	200,044,811
Other KPB	39,079,187	58,186,673	75,571,134	45,399,896	218,236,890
Total	139,905,916	207,045,418	269,077,351	164,267,003	780,295,688
2005					
					Year to Date
Homer	24,327,178	41,463,508	49,872,039		115,662,725
Kenai	29,515,922	37,399,011	42,640,243		109,555,176
Seldovia	572,517	932,156	1,199,541		2,704,214
Seward	10,091,400	25,329,783	38,375,511		73,796,694
Soldotna	38,736,793	52,138,653	69,580,021		160,455,467
Other KPB	41,091,756	62,791,233	77,747,372		181,630,361
Total	144,335,566	220,054,344	279,414,727		643,804,637

Table 1.40

KPB Construction Permitting

KPB 3rd Quarter Permit VALUES by AREA - 1999-2005 - in \$								
	1999	2000	2001	2002	2003	2004	2005	Annual Change
Homer	5,745,000	2,146,970	2,996,350	5,777,330	3,020,075	9,531,900	4,312,500	-54.8%
Kenai	6,122,650	5,094,000	4,506,200	6,814,000	3,700,350	1,991,750	4,035,100	102.6%
Seldovia	87,500	57,900	15,525	318,500	1,835,000	0	30,500	NA
Seward	1,615,749	711,465	642,042	1,307,576	1,832,900	2,266,300	653,661	-71.2%
Soldotna	4,126,579	1,676,910	2,509,916	2,697,346	2,418,310	23,780,115	3,085,730	-87.0%
Total	17,697,478	9,687,245	10,670,033	16,914,752	12,806,635	37,570,065	12,117,491	-67.7%
Annual Change		-45.3%	10.1%	58.5%	-24.3%	193.4%	-67.7%	

Table 1.41

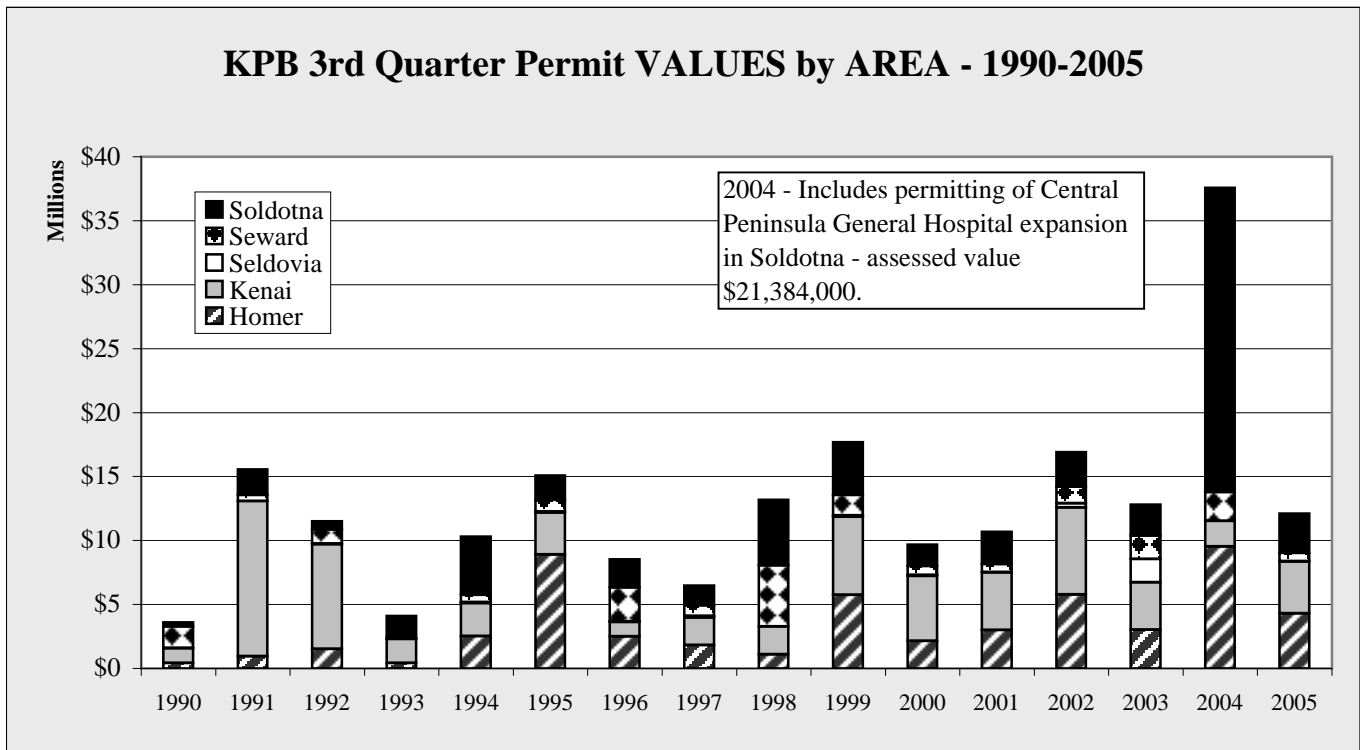

Chart 1.27

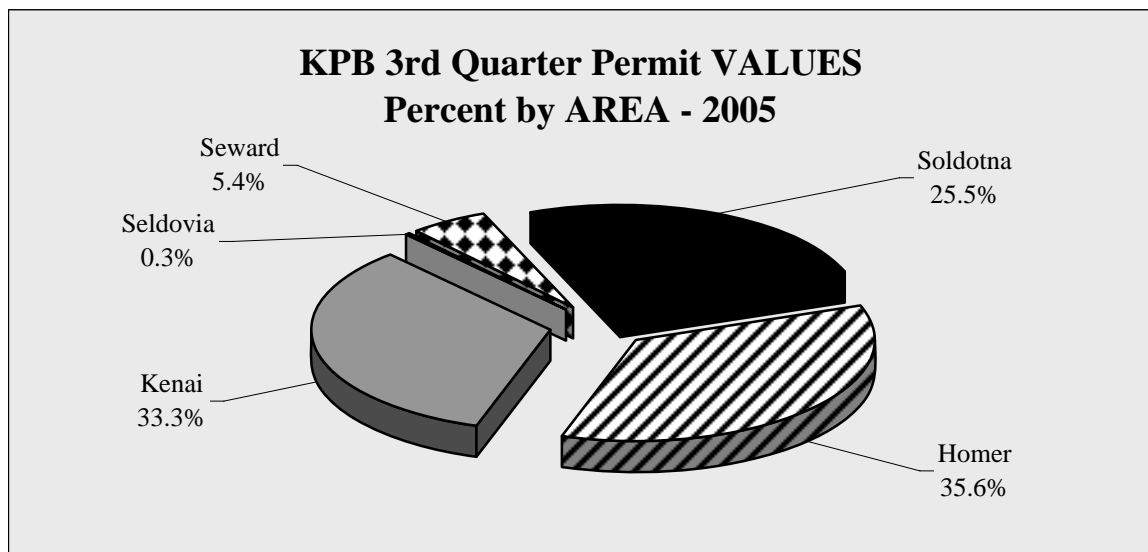

Chart 1.28

KPB Construction Permitting

KPB 3rd Quarter Permit VALUES by TYPE - 1999-2005 - in \$								
	1999	2000	2001	2002	2003	2004	2005	Annual Change
Residential New	3,722,300	3,137,930	3,984,532	5,567,502	4,209,163	4,950,200	4,853,170	-2.0%
Residential Alter/Add	694,267	672,025	531,907	875,861	611,572	1,605,471	795,771	-50.4%
Commercial New	12,808,341	4,966,665	2,707,972	5,955,418	4,636,000	28,989,901	4,841,400	-83.3%
Commercial Alter/Add	472,570	910,625	3,445,622	4,515,971	3,349,900	2,024,493	1,627,150	-19.6%
Total	17,697,478	9,687,245	10,670,033	16,914,752	12,806,635	37,570,065	12,117,491	-67.7%
Annual Change		-45.3%	10.1%	58.5%	-24.3%	193.4%	-67.7%	

Table 1.42

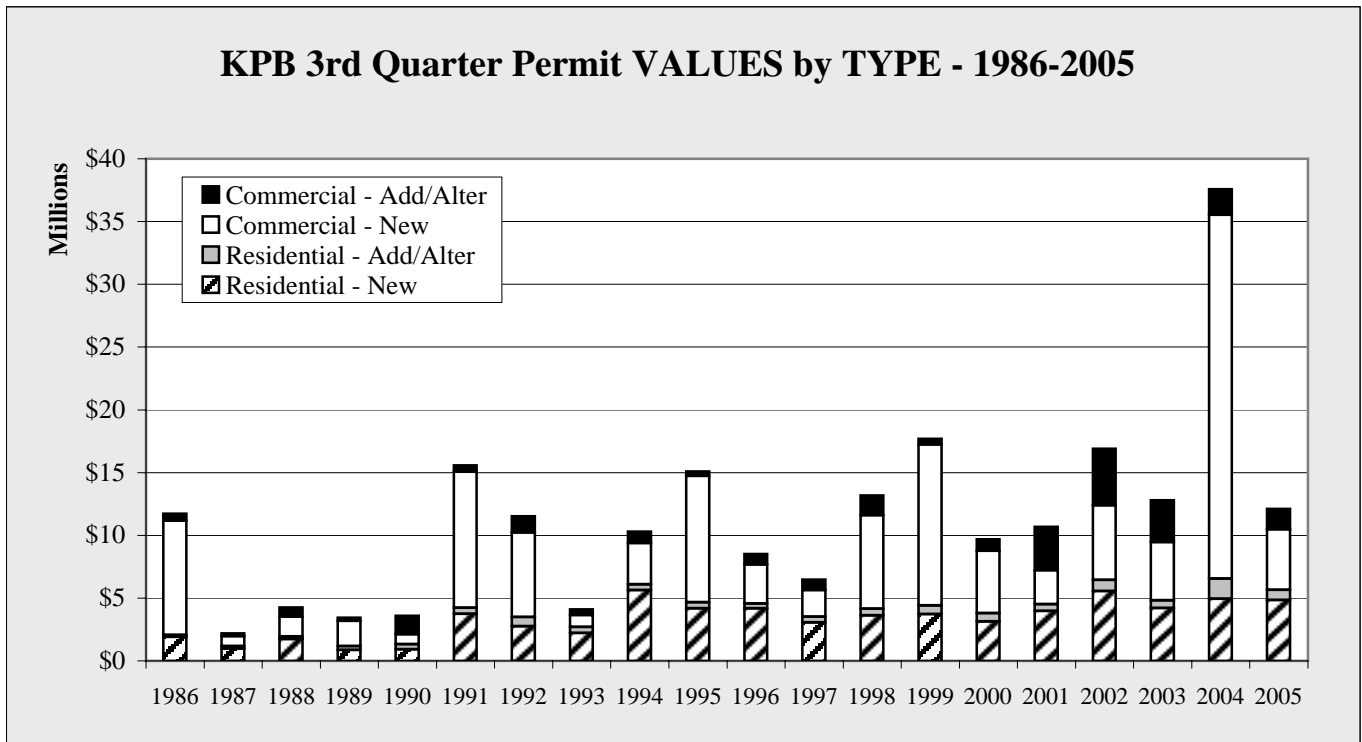

Chart 1.29

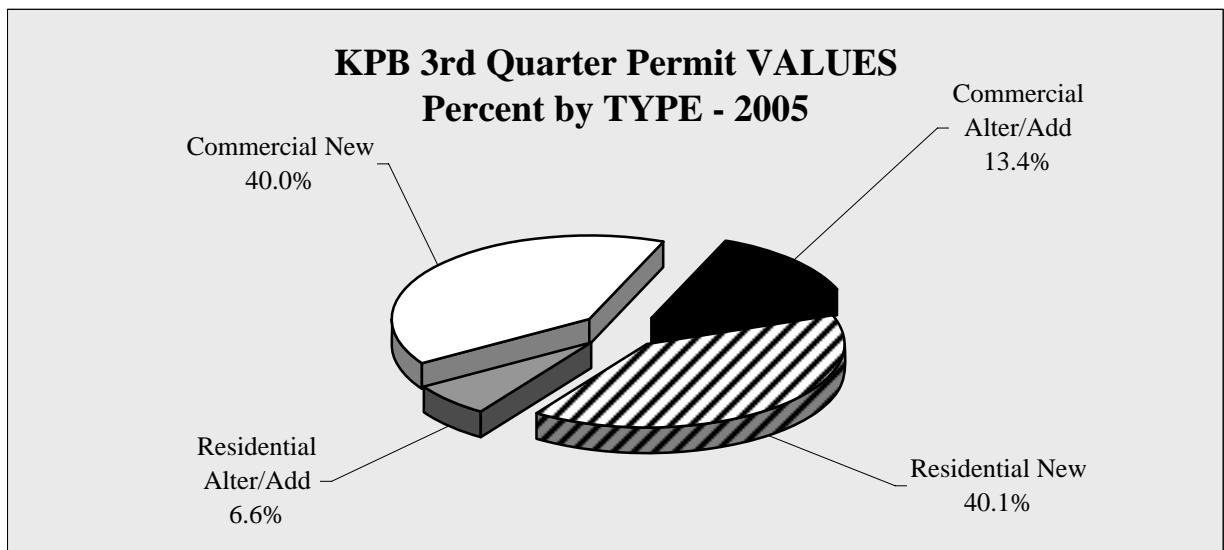

Chart 1.30

KPB Construction Permitting

KPB 3rd Quarter Permit VOLUME by AREA - 1999-2005								
	1999	2000	2001	2002	2003	2004	2005	Annual Change
Homer	20	21	22	27	21	42	27	-35.7%
Kenai	40	36	23	59	45	31	33	6.5%
Seldovia	7	6	5	4	5	0	2	NA
Seward	23	17	14	14	15	19	13	-31.6%
Soldotna	23	26	35	25	19	24	20	-16.7%
Total	113	106	99	129	105	116	95	-18.1%
Annual Change		-6.2%	-6.6%	30.3%	-18.6%	10.5%	-18.1%	

Table 1.43

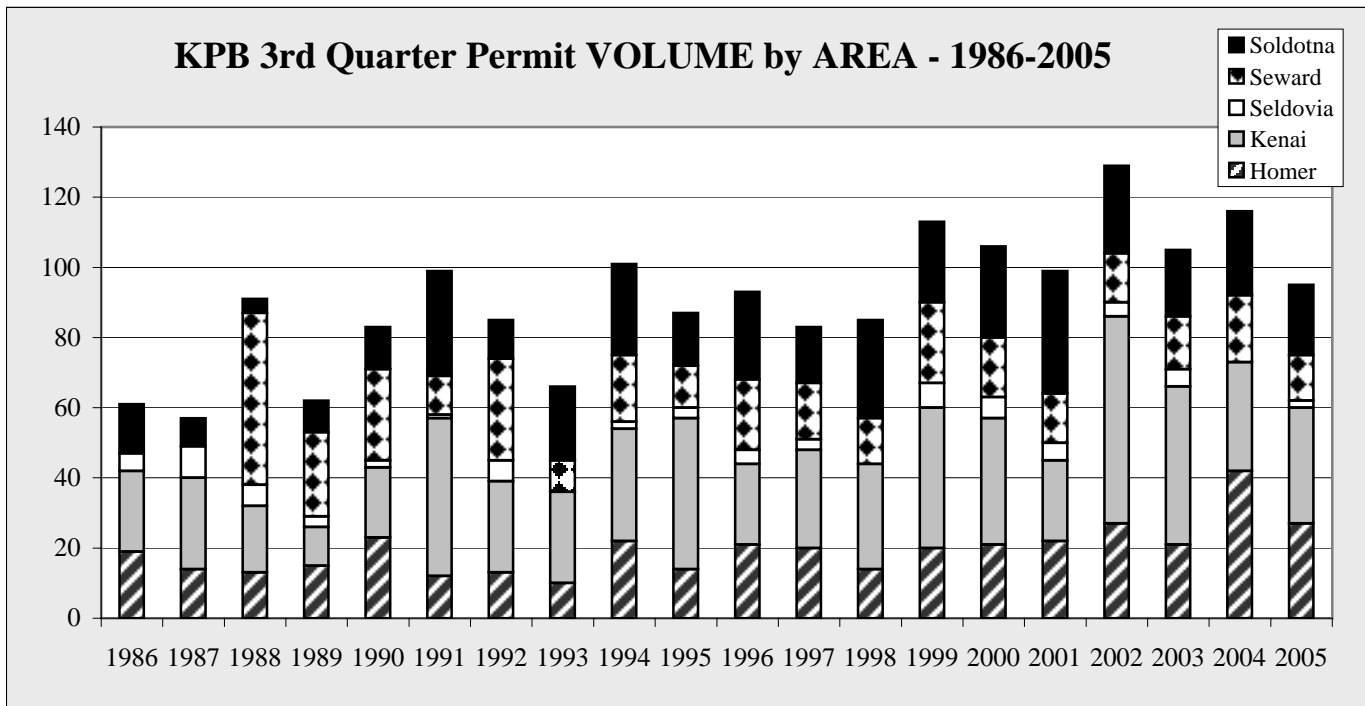

Chart 1.31

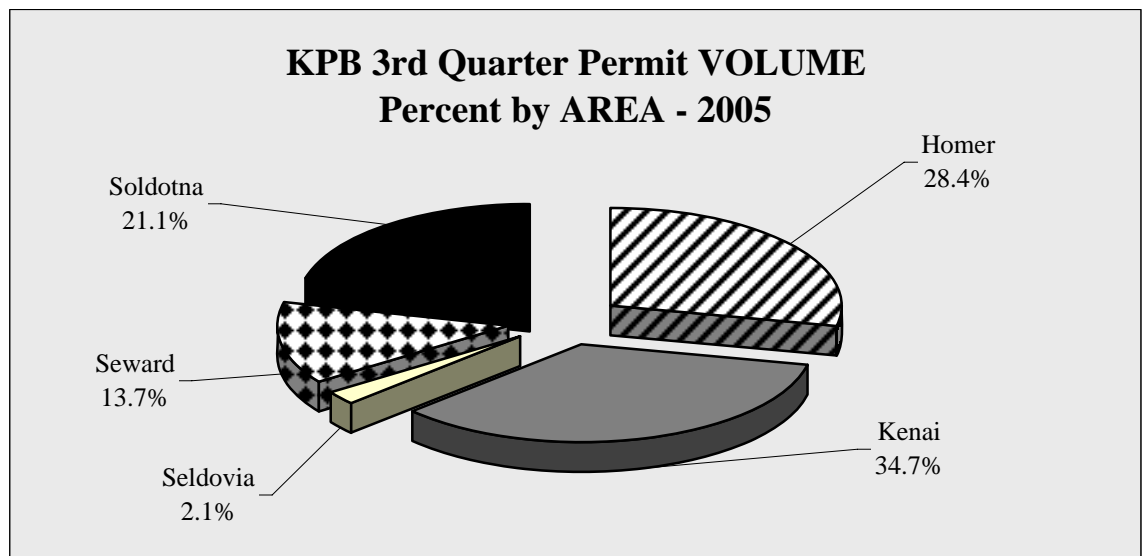

Chart 1.32

KPB Construction Permitting

KPB 3rd Quarter Permit VOLUME by TYPE - 1999-2005

	1999	2000	2001	2002	2003	2004	2005	Annual Change
Residential New	25	28	29	38	28	32	32	0.0%
Residential Alter/Add	36	40	31	49	34	44	35	-20.5%
Commercial New	24	16	15	14	17	15	6	-60.0%
Commercial Alter/Add	28	22	24	28	26	25	22	-12.0%
Total	113	106	99	129	105	116	95	-18.1%
Annual Change		-6.2%	-6.6%	30.3%	-18.6%	10.5%	-18.1%	

Table 1.44

KPB 3rd Quarter Permit VOLUME by TYPE - 1986-2005

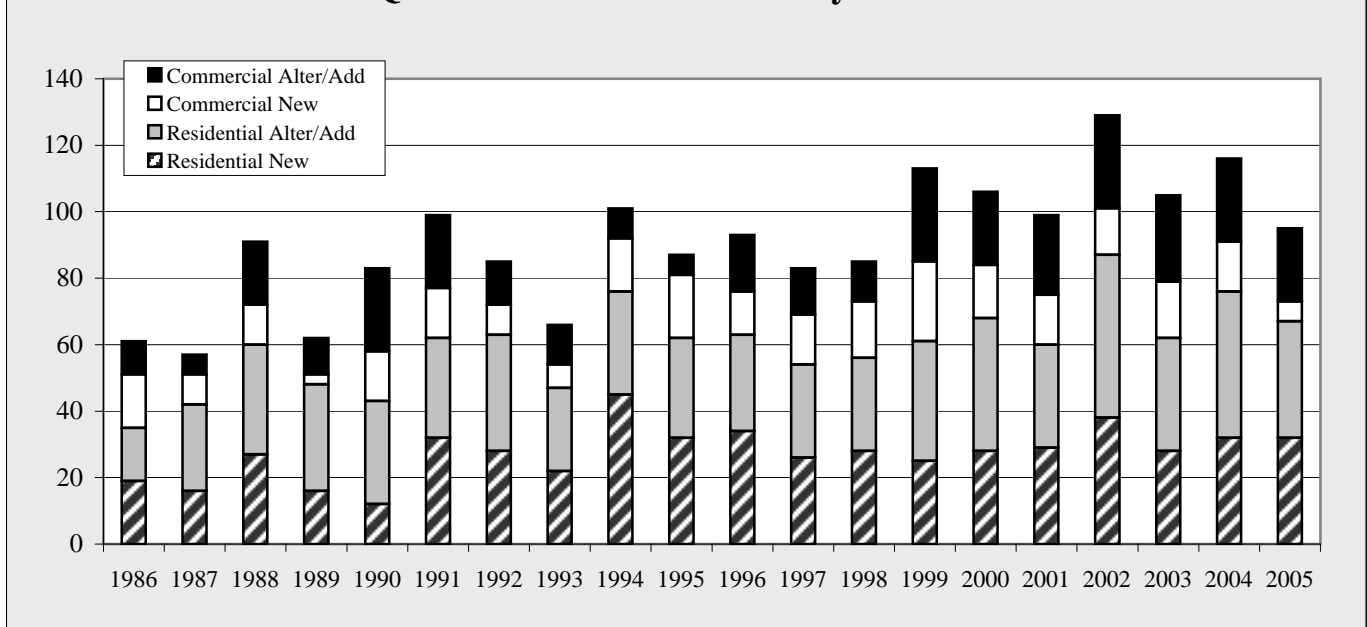

Chart 1.33

**KPB 3rd Quarter Permit VOLUME
Percent by TYPE - 2005**

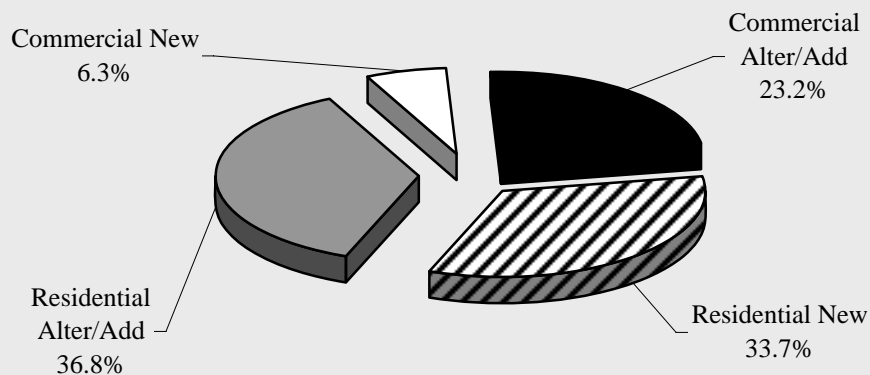

Chart 1.34

KPB Construction Permitting

KPB YTD 9/30 Permit VALUES by AREA - 1999-2005 - in \$								
	1999	2000	2001	2002	2003	2004	2005	Annual Change
Homer	10,379,000	6,210,990	7,788,390	9,234,259	12,283,915	20,679,631	18,660,400	-9.8%
Kenai	8,384,750	8,719,900	12,923,600	15,271,600	7,986,300	4,201,150	7,017,900	67.0%
Seldovia	461,000	104,200	50,525	336,500	1,866,000	176,200	511,500	190.3%
Seward	3,738,413	2,832,165	1,724,981	5,677,903	7,410,265	17,451,800	2,830,501	-83.8%
Soldotna	8,995,327	6,764,468	8,792,324	10,906,394	7,079,252	32,593,011	11,339,520	-65.2%
Total	31,958,490	24,631,723	31,279,820	41,426,656	36,625,732	75,101,792	40,359,821	-46.3%
Annual Change		-22.9%	27.0%	32.4%	-11.6%	105.1%	-46.3%	

Table 1.45

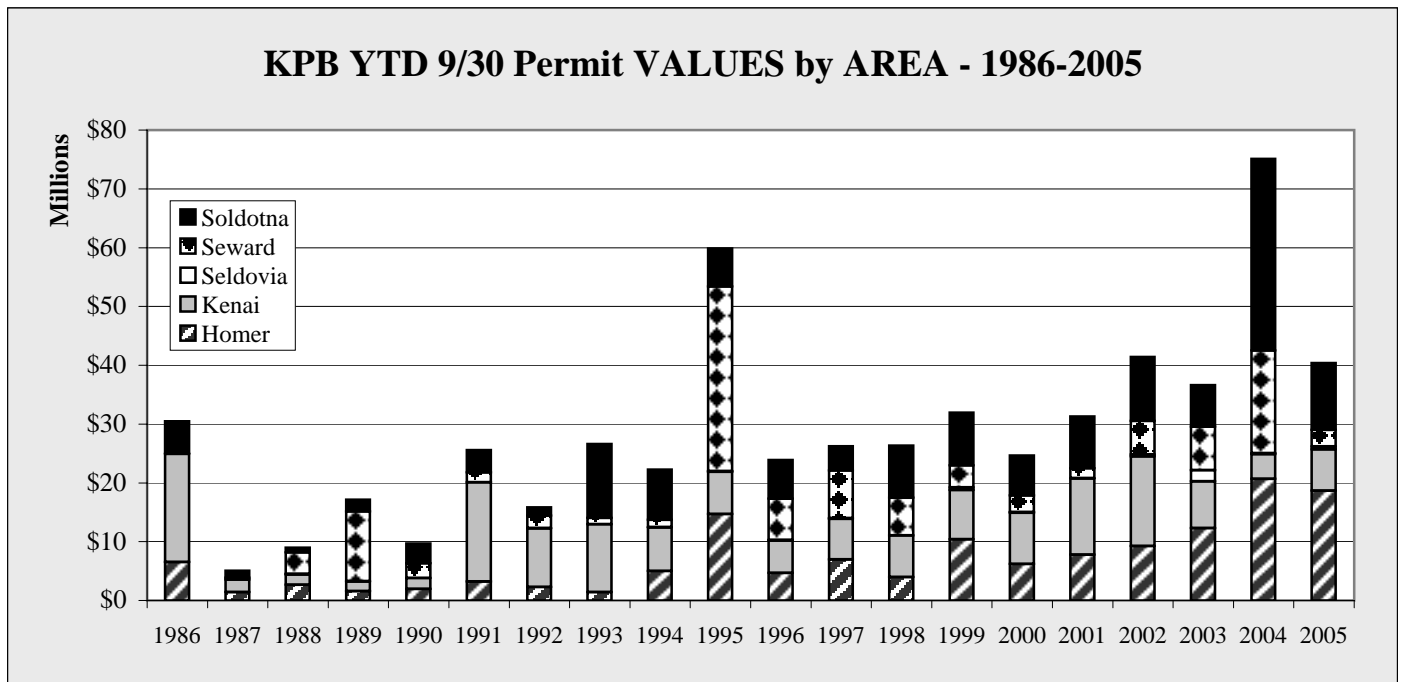

Chart 1.35

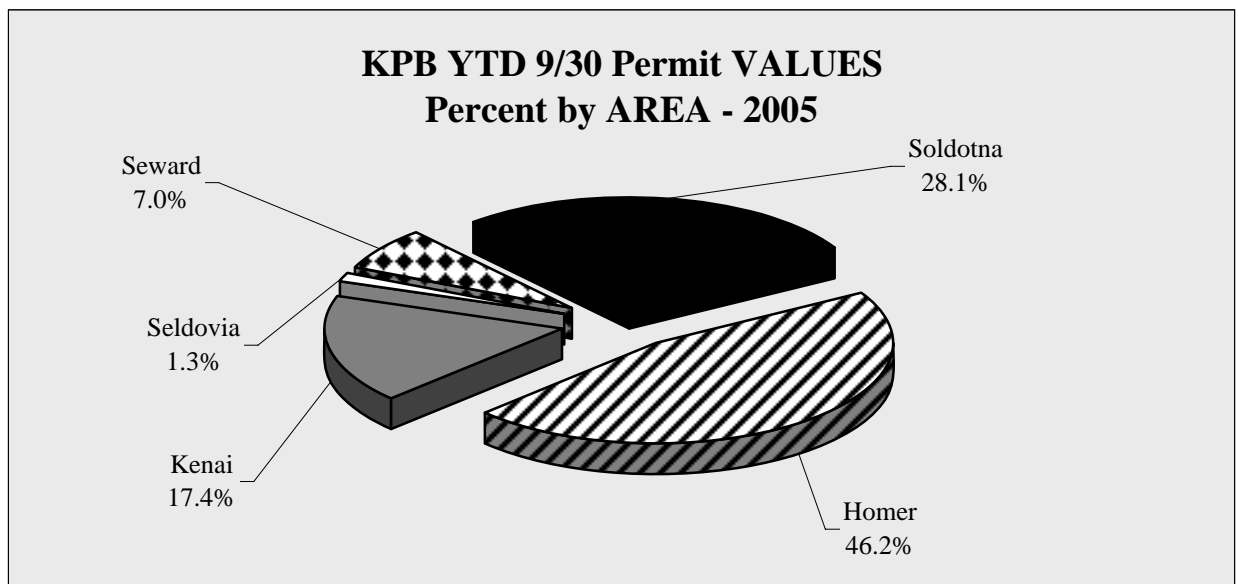

Chart 1.36

KPB Construction Permitting

KPB YTD 9/30 Permit VALUES by TYPE - 1999-2005 - in \$								
	1999	2000	2001	2002	2003	2004	2005	Annual Change
Residential New	10,149,974	8,912,390	12,275,333	13,244,864	13,175,797	14,781,484	15,884,025	7.5%
Residential Alter/Add	1,543,428	1,551,099	1,647,546	2,080,195	1,989,779	2,350,830	2,048,471	-12.9%
Commercial New	17,899,659	9,200,060	11,051,350	18,625,729	13,673,210	53,017,742	17,043,248	-67.9%
Commercial Alter/Add	2,365,429	4,968,174	6,305,591	7,475,868	7,786,946	4,951,736	5,384,077	8.7%
Total	31,958,490	24,631,723	31,279,820	41,426,656	36,625,732	75,101,792	40,359,821	-46.3%
Annual Change		-22.9%	27.0%	32.4%	-11.6%	105.1%	-46.3%	

Table 1.46

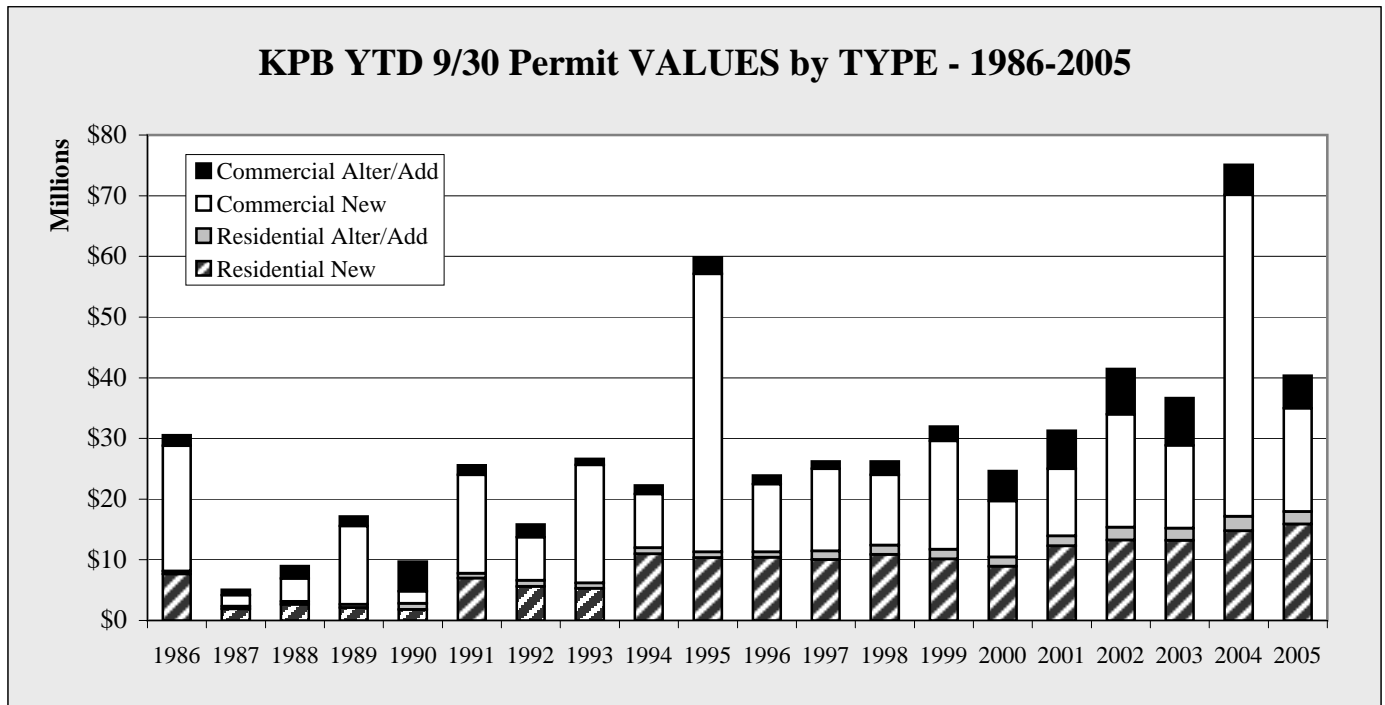

Chart 1.37

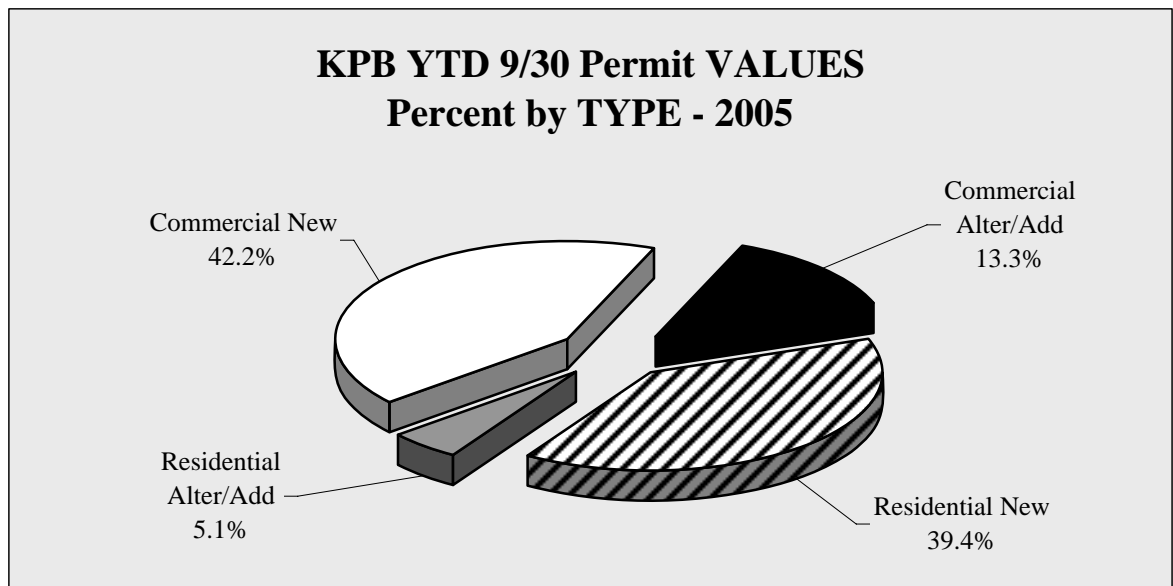

Chart 1.38

KPB Construction Permitting

KPB YTD 9/30 Permit VOLUME by AREA - 1999-2005								
	1999	2000	2001	2002	2003	2004	2005	Annual Change
Homer	46	50	63	54	73	84	92	9.5%
Kenai	80	80	76	101	93	65	76	16.9%
Seldovia	17	12	7	7	8	4	9	125.0%
Seward	46	42	39	53	39	47	47	0.0%
Soldotna	68	68	82	87	61	59	76	28.8%
Total	257	252	267	302	274	259	300	15.8%
Annual Change		-1.9%	6.0%	13.1%	-9.3%	-5.5%	15.8%	

Table 1.47

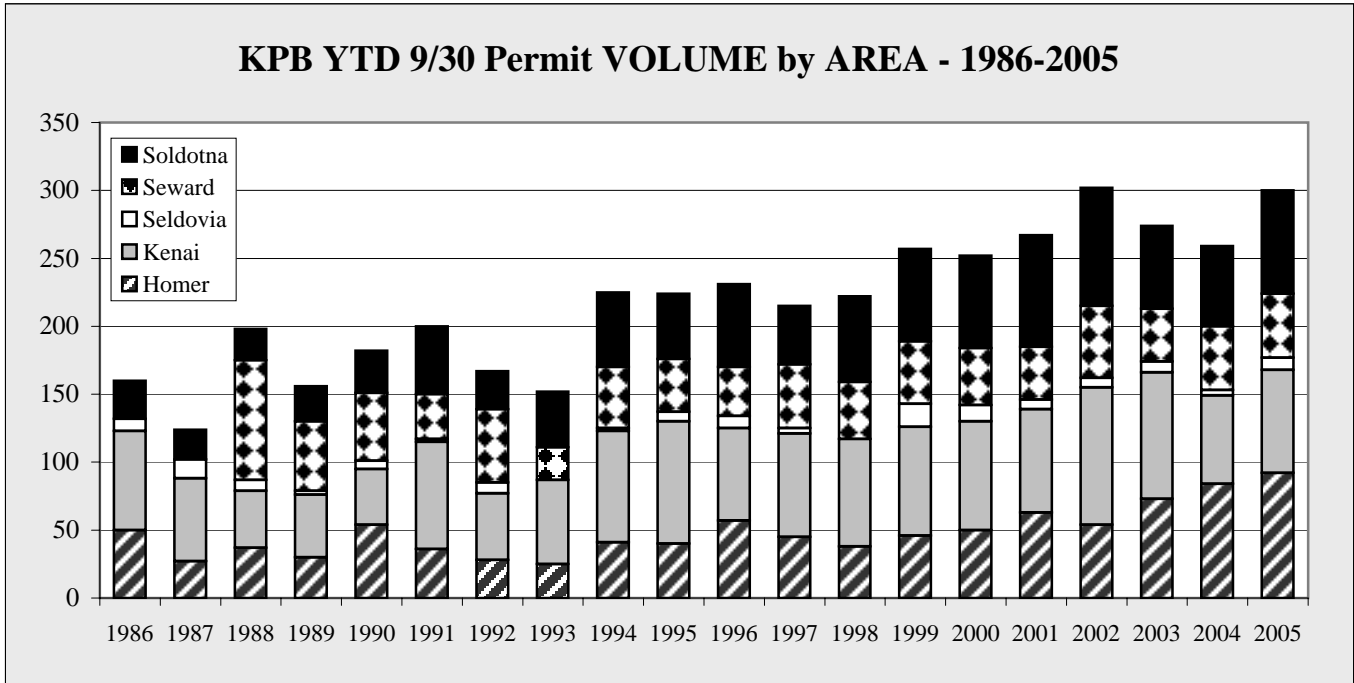

Chart 1.39

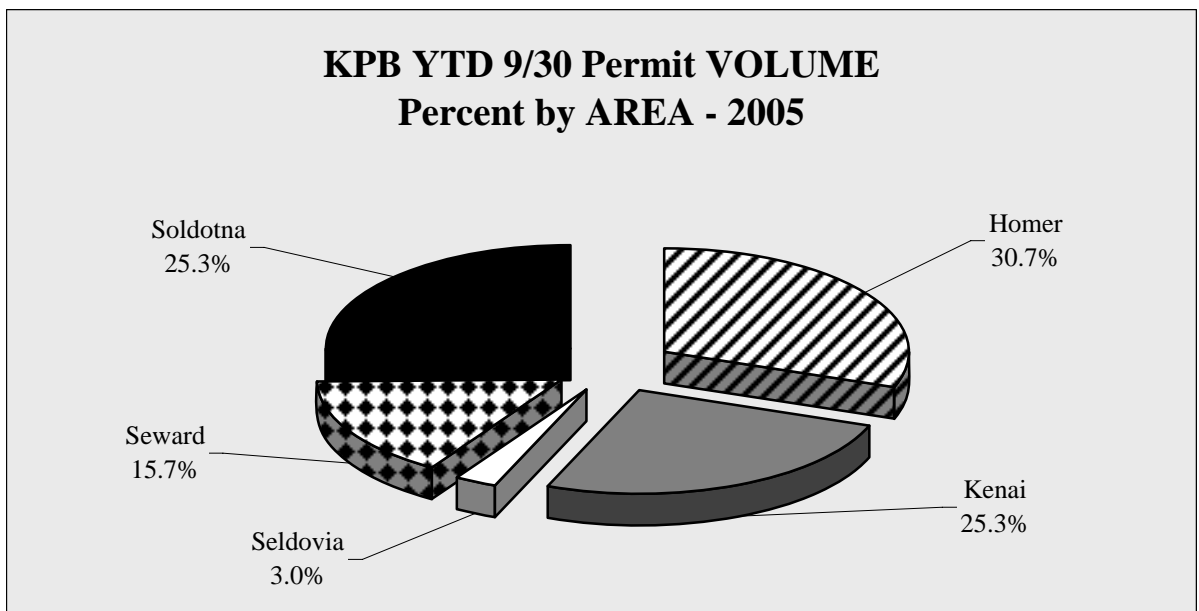

Chart 1.40

KPB Construction Permitting

KPB YTD 9/30 Permit VOLUME by TYPE - 1999-2005

	1999	2000	2001	2002	2003	2004	2005	Annual Change
Residential New	66	70	81	95	82	83	99	19.3%
Residential Alter/Add	80	82	82	99	84	79	102	29.1%
Commercial New	48	33	30	36	35	33	36	9.1%
Commercial Alter/Add	63	67	74	72	73	64	63	-1.6%
Total	257	252	267	302	274	259	300	15.8%
Annual Change		-1.9%	6.0%	13.1%	-9.3%	-5.5%	15.8%	

Table 1.48

KPB YTD 9/30 Permit VOLUME by TYPE - 1986-2005

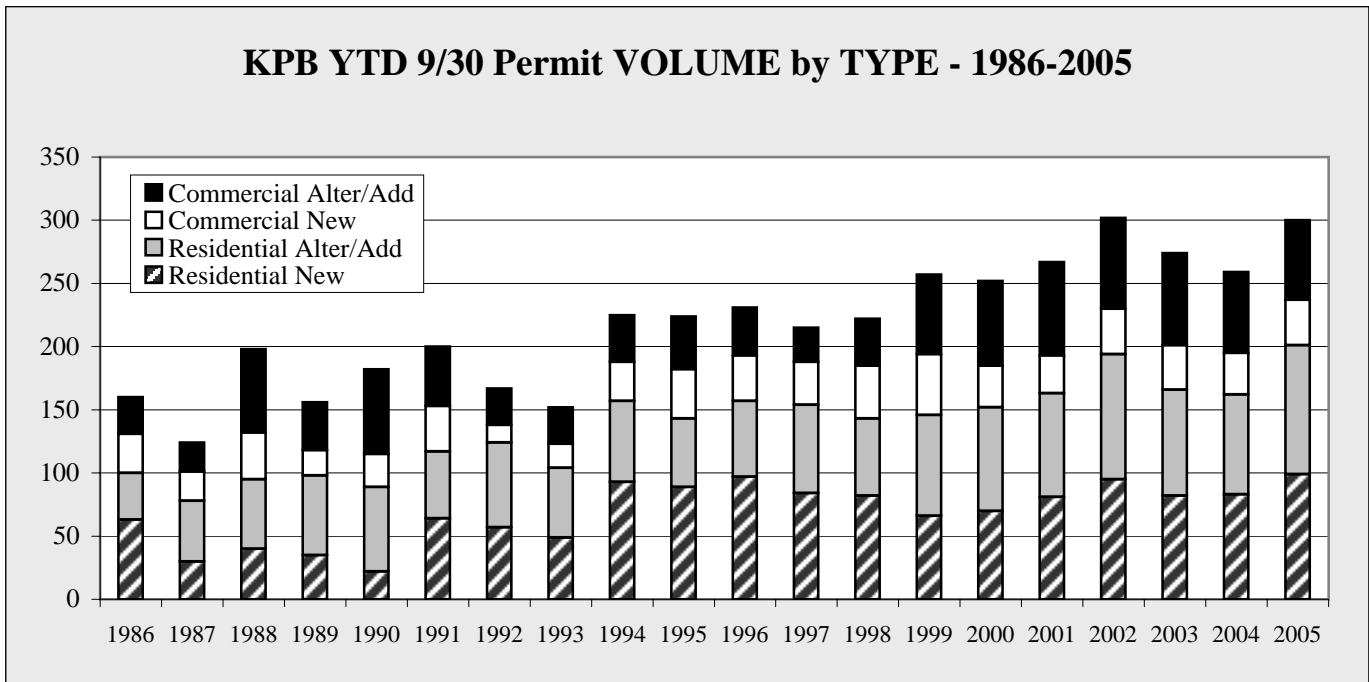

Chart 1.41

**KPB YTD 9/30 Permit VOLUME
Percent by TYPE - 2005**

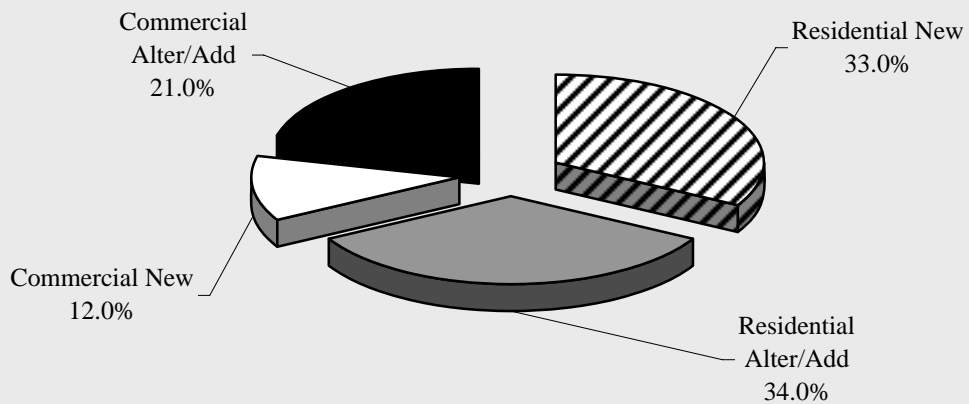

Chart 1.42

KPB Construction Permitting

KPB Permit VALUES by AREA - 1999-2005 - in \$					
	1st Quarter	2nd Quarter	3rd Quarter	4th Quarter	Total
1999					
Homer	1,943,000	2,691,000	5,745,000	561,000	10,940,000
Kenai	239,500	2,022,600	6,122,650	1,057,000	9,441,750
Seldovia	8,000	365,500	87,500	18,000	479,000
Seward	1,040,550	1,082,114	1,615,749	503,000	4,241,413
Soldotna	83,696	4,785,052	4,126,579	509,793	9,505,120
TOTAL	3,314,746	10,946,266	17,697,478	2,648,793	34,607,283
2000					
Homer	1,798,100	2,265,920	2,146,970	917,982	7,128,972
Kenai	462,900	3,163,000	5,094,000	678,200	9,398,100
Seldovia	24,000	22,300	57,900	5,000	109,200
Seward	355,300	1,765,400	711,465	619,400	3,451,565
Soldotna	1,078,202	4,009,356	1,676,910	1,402,952	8,167,420
TOTAL	3,718,502	11,225,976	9,687,245	3,623,534	28,255,257
2001					
Homer	690,000	4,102,040	2,996,350	12,012,300	19,800,690
Kenai	819,500	7,597,900	4,506,200	655,300	13,578,900
Seldovia	10,000	25,000	15,525	15,000	65,525
Seward	416,700	666,239	642,042	992,000	2,716,981
Soldotna	3,051,218	3,231,190	2,509,916	162,648	8,954,972
TOTAL	4,987,418	15,622,369	10,670,033	13,837,248	45,117,068
2002					
Homer	928,720	2,528,209	5,777,330	814,520	10,048,779
Kenai	3,888,200	4,569,400	6,814,000	1,527,800	16,799,400
Seldovia	10,000	8,000	318,500	20,000	356,500
Seward	481,440	3,888,887	1,307,576	2,232,800	7,910,703
Soldotna	1,205,590	7,003,458	2,697,346	257,500	11,163,894
TOTAL	6,513,950	17,997,954	16,914,752	4,852,620	46,279,276
2003					
Homer	1,334,340	7,929,500	3,020,075	3,042,900	15,326,815
Kenai	1,557,600	2,728,350	3,700,350	2,455,500	10,441,800
Seldovia	31,000	0	1,835,000	36,500	1,902,500
Seward	1,905,355	3,672,010	1,832,900	572,500	7,982,765
Soldotna	427,018	4,233,924	2,418,310	873,045	7,952,297
TOTAL	5,255,313	18,563,784	12,806,635	6,980,445	43,606,177
2004					
Homer	3,714,020	7,433,711	9,531,900	3,391,000	24,070,631
Kenai	312,000	1,897,400	1,991,750	585,400	4,786,550
Seldovia	20,000	156,200	0	0	176,200
Seward	7,741,600	7,443,900	2,266,300	259,350	17,711,150
Soldotna	5,064,323	3,748,573	23,780,115	4,703,915	37,296,926
TOTAL	16,851,943	20,679,784	37,570,065	8,939,665	84,041,457
2005					Year to Date
Homer	3,105,900	11,242,000	4,312,500		18,660,400
Kenai	425,500	2,557,300	4,035,100		7,017,900
Seldovia	15,000	466,000	30,500		511,500
Seward	1,507,300	669,540	653,661		2,830,501
Soldotna	1,421,555	6,832,235	3,085,730		11,339,520
TOTAL	6,475,255	21,767,075	12,117,491		40,359,821

Table 1.49

KPB Construction Permitting

KPB Permit VALUES by TYPE - 1999-2005 - in \$					
	1st Quarter	2nd Quarter	3rd Quarter	4th Quarter	Total
1999					
Residential - New	1,673,000	4,754,674	3,722,300	1,245,888	11,395,862
Residential - Add/Alter	181,200	667,961	694,267	291,400	1,834,828
Commercial - New	292,500	4,798,818	12,808,341	962,905	18,862,564
Commercial - Add/Alter	1,168,046	724,813	472,570	148,600	2,514,029
TOTAL	3,314,746	10,946,266	17,697,478	2,648,793	34,607,283
2000					
Residential - New	1,242,529	4,531,931	3,137,930	972,668	9,885,058
Residential - Add/Alter	18,500	860,574	672,025	439,300	1,990,399
Commercial - New	669,273	3,564,122	4,966,665	1,462,484	10,662,544
Commercial - Add/Alter	1,788,200	2,269,349	910,625	749,082	5,717,256
TOTAL	3,718,502	11,225,976	9,687,245	3,623,534	28,255,257
2001					
Residential - New	923,000	7,367,801	3,984,532	1,116,300	13,391,633
Residential - Add/Alter	356,860	758,779	531,907	348,948	1,996,494
Commercial - New	2,958,578	5,384,800	2,707,972	514,000	11,565,350
Commercial - Add/Alter	748,980	2,110,989	3,445,622	11,858,000	18,163,591
TOTAL	4,987,418	15,622,369	10,670,033	13,837,248	45,117,068
2002					
Residential - New	1,531,609	6,145,753	5,567,502	1,113,200	14,358,064
Residential - Add/Alter	159,391	1,044,943	875,861	225,620	2,305,815
Commercial - New	4,294,006	8,376,305	5,955,418	3,168,000	21,793,729
Commercial - Add/Alter	528,944	2,430,953	4,515,971	345,800	7,821,668
TOTAL	6,513,950	17,997,954	16,914,752	4,852,620	46,279,276
2003					
Residential - New	1,097,800	7,868,834	4,209,163	2,554,091	15,729,888
Residential - Add/Alter	393,867	984,340	611,572	291,000	2,280,779
Commercial - New	72,000	8,965,210	4,636,000	2,146,991	15,820,201
Commercial - Add/Alter	3,691,646	745,400	3,349,900	1,988,363	9,775,309
TOTAL	5,255,313	18,563,784	12,806,635	6,980,445	43,606,177
2004					
Residential - New	3,456,797	6,374,487	4,950,200	1,153,860	15,935,344
Residential - Add/Alter	261,520	483,839	1,605,471	529,454	2,880,284
Commercial - New	12,880,026	11,147,815	28,989,901	3,061,601	56,079,343
Commercial - Add/Alter	253,600	2,673,643	2,024,493	4,194,750	9,146,486
TOTAL	16,851,943	20,679,784	37,570,065	8,939,665	84,041,457
2005					
					Year to Date
Residential - New	3,470,356	7,560,499	4,853,170		15,884,025
Residential - Add/Alter	418,930	833,770	795,771		2,048,471
Commercial - New	509,000	11,692,848	4,841,400		17,043,248
Commercial - Add/Alter	2,076,969	1,679,958	1,627,150		5,384,077
TOTAL	6,475,255	21,767,075	12,117,491		40,359,821

Table 1.50

KPB Construction Permitting

KPB Permit VOLUME by AREA - 1999-2005					
	1st Quarter	2nd Quarter	3rd Quarter	4th Quarter	Total
1999					
Homer	5	21	20	6	52
Kenai	7	33	40	22	102
Seldovia	1	9	7	3	20
Seward	5	18	23	10	56
Soldotna	10	35	23	9	77
TOTAL	28	116	113	50	307
2000					
Homer	9	20	21	8	58
Kenai	8	36	36	13	93
Seldovia	3	3	6	1	13
Seward	5	20	17	9	51
Soldotna	8	34	26	20	88
TOTAL	33	113	106	51	303
2001					
Homer	7	34	22	9	72
Kenai	11	42	23	11	87
Seldovia	1	1	5	2	9
Seward	11	14	14	9	48
Soldotna	10	37	35	11	93
TOTAL	40	128	99	42	309
2002					
Homer	10	17	27	13	67
Kenai	5	37	59	20	121
Seldovia	1	2	4	1	8
Seward	10	29	14	11	64
Soldotna	11	51	25	4	91
TOTAL	37	136	129	49	351
2003					
Homer	18	34	21	13	86
Kenai	8	40	45	21	114
Seldovia	3	0	5	4	12
Seward	11	13	15	11	50
Soldotna	6	36	19	13	74
TOTAL	46	123	105	62	336
2004					
Homer	16	26	42	24	108
Kenai	4	30	31	14	79
Seldovia	1	3	0	0	4
Seward	7	21	19	7	54
Soldotna	9	26	24	8	67
TOTAL	37	106	116	53	312
2005					Year to Date
Homer	18	47	27		92
Kenai	10	33	33		76
Seldovia	1	6	2		9
Seward	13	21	13		47
Soldotna	16	40	20		76
TOTAL	58	147	95		300

Table 1.51

KPB Construction Permitting

KPB Permit VOLUME by TYPE - 1999-2005					
	1st Quarter	2nd Quarter	3rd Quarter	4th Quarter	Total
1999					
Residential - New	3	38	25	13	79
Residential - Add/Alter	8	36	36	18	98
Commercial - New	4	20	24	9	57
Commercial - Add/Alter	13	22	28	10	73
TOTAL	28	116	113	50	307
2000					
Residential - New	10	32	28	9	79
Residential - Add/Alter	4	38	40	15	97
Commercial - New	4	13	16	12	45
Commercial - Add/Alter	15	30	22	15	82
TOTAL	33	113	106	51	303
2001					
Residential - New	7	45	29	8	89
Residential - Add/Alter	13	38	31	14	96
Commercial - New	6	9	15	2	32
Commercial - Add/Alter	14	36	24	18	92
TOTAL	40	128	99	42	309
2002					
Residential - New	12	45	38	9	104
Residential - Add/Alter	8	42	49	17	116
Commercial - New	5	17	14	7	43
Commercial - Add/Alter	12	32	28	16	88
TOTAL	37	136	129	49	351
2003					
Residential - New	7	47	28	22	104
Residential - Add/Alter	17	33	34	10	94
Commercial - New	1	17	17	7	42
Commercial - Add/Alter	21	26	26	23	96
TOTAL	46	123	105	62	336
2004					
Residential - New	17	34	32	11	94
Residential - Add/Alter	5	30	44	17	96
Commercial - New	7	11	15	9	42
Commercial - Add/Alter	8	31	25	16	80
TOTAL	37	106	116	53	312
2005					Year to Date
Residential - New	18	49	32		99
Residential - Add/Alter	15	52	35		102
Commercial - New	6	24	6		36
Commercial - Add/Alter	19	22	22		63
TOTAL	58	147	95		300

Table 1.52

KPB Employment

Employment data are acquired from the Alaska Department of Labor and Workforce Development (AK DOLWD) as reported by administrative personnel of each business. When administrative headquarters of a business is located in a specific area, all employees of that business are reported as being employed in that area, resulting in skewed employment data.

Government employees include federal, state, borough and local government as well as public school and state university employees. Employees of both Central Peninsula General Hospital in Soldotna and South Peninsula General Hospital in Homer are included in government data because they are managed by the KPB.

The AK DOLWD updates employment data regularly as information trickles in and adjustments are made. Data varies in quarterly reports as corrected reports are received or delinquent reports are filed and included in totals. Self-employed workers, fishers, domestics and unpaid family workers are excluded from these data due to exemption from certain reporting requirements.

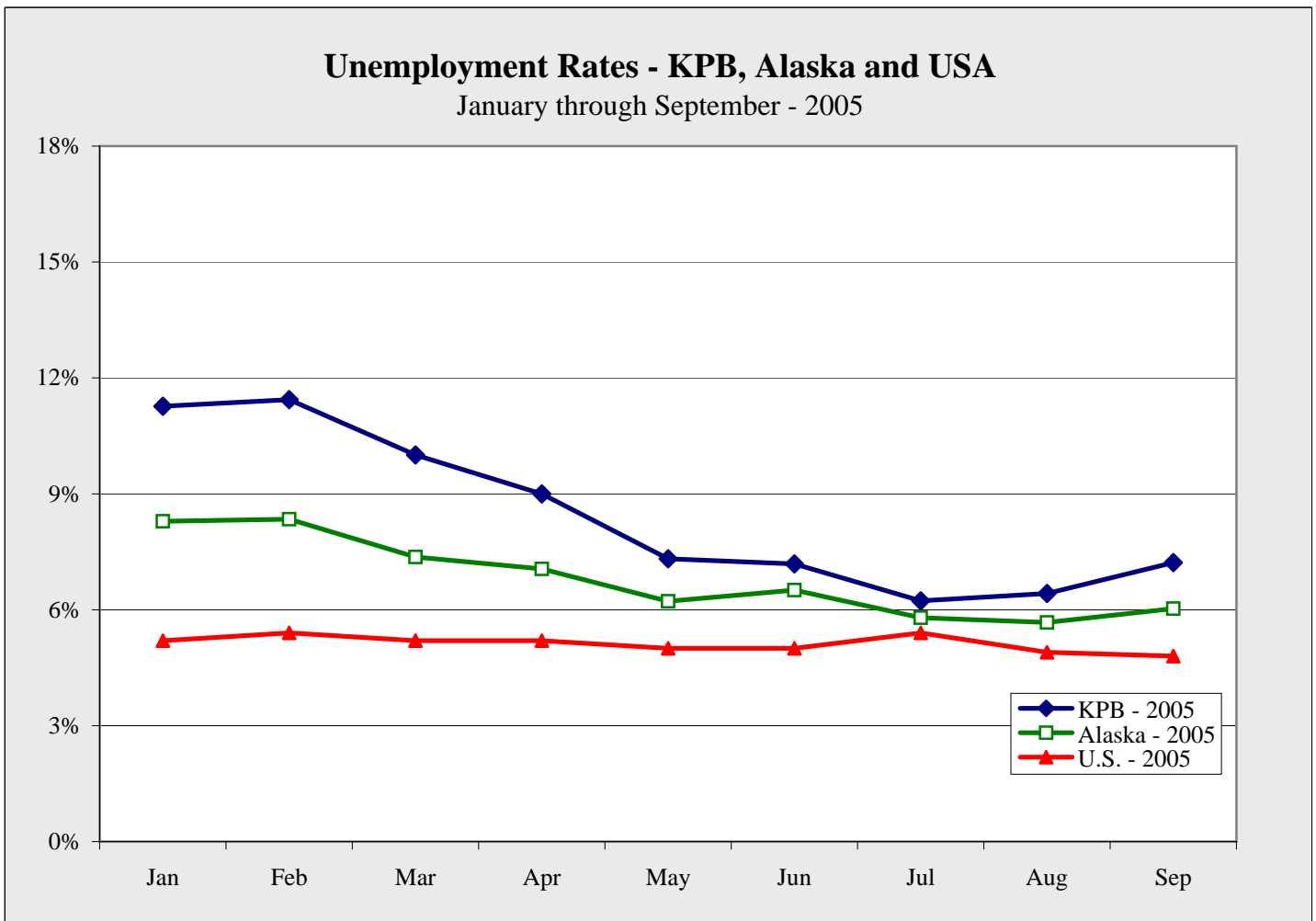

Chart 1.43

KPB Employment

KPB Labor Force by Month - 2003-2005

	Jan	Feb	Mar	Apr	May	Jun	Jul	Aug	Sep	Oct	Nov	Dec	Avg
2003	24,298	24,108	24,243	24,379	25,394	26,781	27,170	26,352	24,571	24,028	23,988	23,875	24,932
2004	23,874	24,000	24,130	24,130	25,302	27,119	27,599	26,342	24,958	24,334	24,116	23,981	24,990
2005	23,873	24,157	24,295	24,749	25,830	27,354	27,932	26,552	25,377				

Table 1.53

KPB Comparative Labor Force by Month - YTD 2003, 2004, 2005

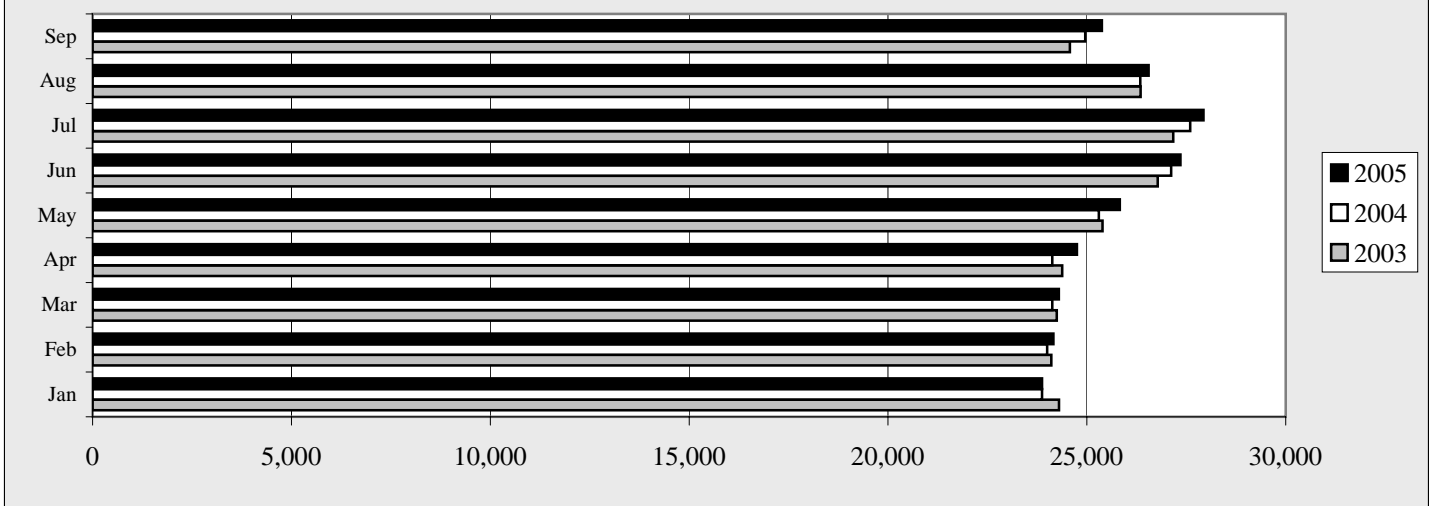

Chart 1.44

KPB Unemployment by Month - 2003-2005

	Jan	Feb	Mar	Apr	May	Jun	Jul	Aug	Sep	Oct	Nov	Dec	Avg
2003	2,935	3,048	2,795	2,564	2,345	2,542	2,169	2,122	2,126	2,301	2,508	2,636	2,508
2004	2,956	2,969	2,897	2,508	2,272	2,419	2,033	1,956	1,971	2,129	2,309	2,429	2,404
2005	2,690	2,763	2,431	2,227	1,891	1,966	1,740	1,705	1,832				

Table 1.54

KPB Comparative Unemployment by Month - YTD 2003, 2004, 2005

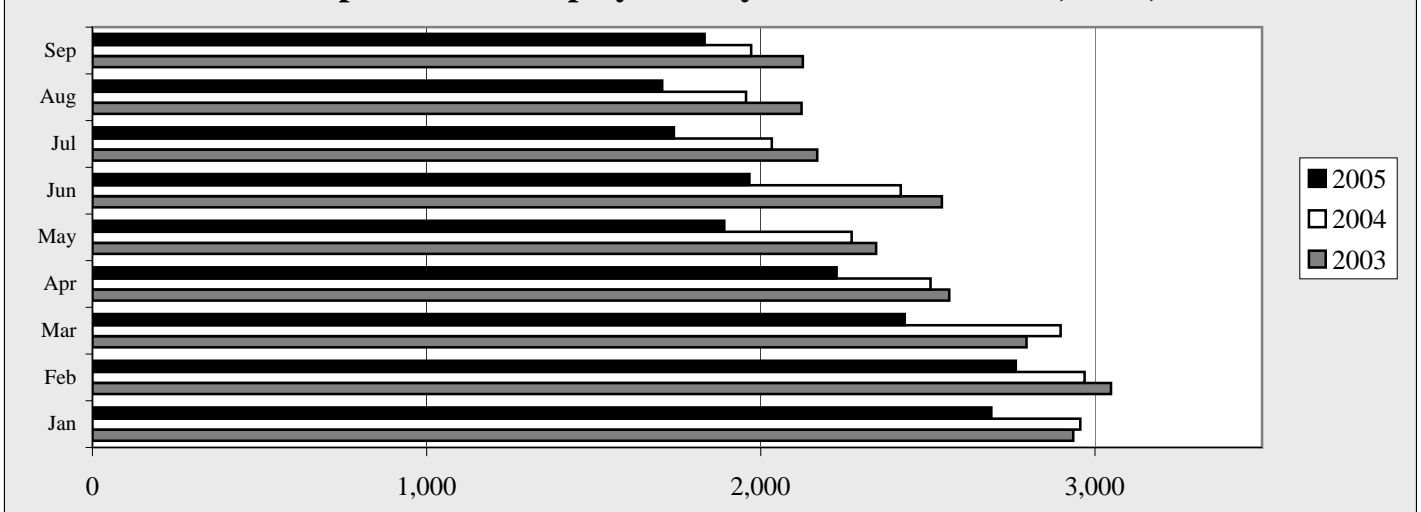

Chart 1.45

KPB Employment

Unemployment Rates by Month - 2003-2005

	Jan	Feb	Mar	Apr	May	Jun	Jul	Aug	Sep	Oct	Nov	Dec	Avg
2003	12.1%	12.6%	11.5%	10.5%	9.2%	9.5%	8.0%	8.1%	8.7%	9.6%	10.5%	11.0%	10.1%
2004	12.4%	12.4%	12.0%	10.4%	9.0%	8.9%	7.4%	7.4%	7.9%	8.7%	9.6%	10.1%	9.7%
2005	11.3%	11.4%	10.0%	9.0%	7.3%	7.2%	6.2%	6.4%	7.2%				

Table 1.55

KPB Comparative Unemployment Rates - 2003, 2004, 2005

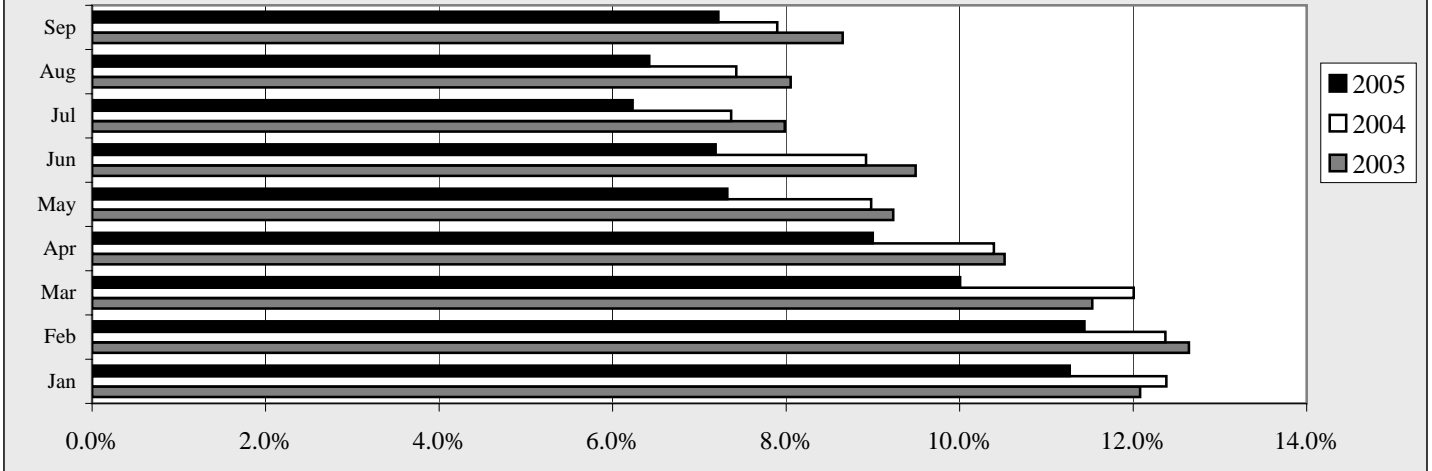

Chart 1.46

Employment by Month - 2003-2005

	Jan	Feb	Mar	Apr	May	Jun	Jul	Aug	Sep	Oct	Nov	Dec	Avg
2003	21,363	21,060	21,448	21,815	23,049	24,239	25,001	24,230	22,445	21,727	21,480	21,239	22,425
2004	20,918	21,031	21,233	21,622	23,030	24,700	25,566	24,386	22,987	22,205	21,807	21,552	22,586
2005	21,183	21,394	21,864	22,522	23,939	25,388	26,192	24,847	23,545				

Table 1.56

KPB Comparative Employment by Month - 2003, 2004, 2005

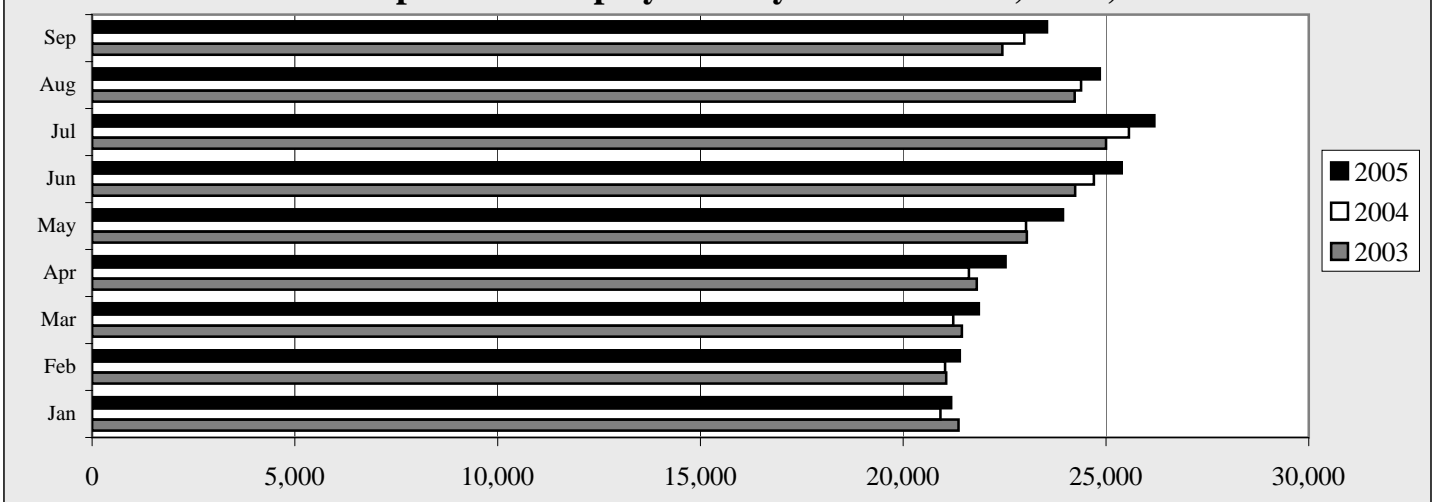

Chart 1.47

KPB Population

KPB CDP's Population Estimates - 2000 - 2004						
KPB Community	2000 Census	June 1 Estimate (Subject to Annual Revision)				Annual Change
		2001	2002	2003	2004	
Anchor Point	1,845	1,809	1,784	1,812	1,792	-1.10%
Bear Creek	1,748	1,836	1,832	1,835	1,897	3.40%
Beluga	32	24	25	27	26	-3.70%
Clam Gulch	173	168	173	176	164	-6.80%
Cohoe	1,168	1,175	1,209	1,206	1,312	8.80%
Cooper Landing	369	391	372	358	351	-2.00%
Crown Point	75	89	88	78	89	14.10%
Diamond Ridge*	1,802	1,812	404	306	761	148.70%
Fox River	616	594	574	572	587	2.60%
Fritz Creek	1,603	1,662	1,735	1,744	1,732	-0.70%
Funny River	636	624	688	707	727	2.80%
Halibut Cove	35	29	28	27	26	-3.70%
Happy Valley	489	505	521	505	525	4.00%
Homer*	3,946	4,065	5,527	5,865	5,332	-9.10%
Hope	137	145	152	161	165	2.50%
Kachemak	431	426	433	478	475	-0.60%
Kalifornsky	5,846	6,011	6,153	6,249	6,617	5.90%
Kasilof	471	451	504	568	473	-16.70%
Kenai	6,942	6,870	7,071	7,123	6,809	-4.40%
Lowell Point	92	96	108	89	74	-16.90%
Miller Landing*	74	70				
Moose Pass	206	206	217	221	220	-0.50%
Nanwalek	177	184	219	214	203	-5.10%
Nikiski	4,327	4,362	4,360	4,356	4,279	-1.80%
Nikolaevsk	345	345	331	312	306	-1.90%
Ninilchik	772	758	760	774	783	1.20%
Port Graham	171	178	174	165	153	-7.30%
Primrose	93	98	92	86	90	4.70%
Ridgeway	1,932	1,961	1,963	2,022	2,047	1.20%
Salamatof	954	894	897	904	900	-0.40%
Seldovia**	430	435	450	431	426	-1.20%
Seldovia City**	286	285	288	279	263	-5.70%
Seldovia Village**	144	150	166	155	170	9.70%
Seward	2,830	2,759	2,754	2,745	2,540	-7.50%
Soldotna	3,759	3,791	3,856	3,992	3,767	-5.60%
Sterling	4,705	4,753	4,771	4,880	4,940	1.20%
Sunrise	18	16	14	15	19	26.70%
Tyonek	193	161	181	192	184	-4.20%
Remainder Kenai/Cook Inlet census sub area		229	188	190	181	-4.70%
Remainder Seward census sub area		23	13	13	8	-38.50%
Remainder of KPB	249					
Kenai Peninsula Borough	49,691	50,005	50,621	51,398	50,980	-0.80%

Table 1.57

* - Homer annexation included all of Miller Landing CDP and part of Diamond Ridge CDP. Annexation was effective March 20, 2002.

**Seldovia City plus Seldovia Village is not equal to the Seldovia CDP.

Note - All Estimates since 2000 have been revised by the State of Alaska Department of Labor and Workforce Development.

KPB Population

KPB Census by CDP - 1940-2000									
KPB Community	KPB Region	1940							10 Year Change
		1940	1950	1960	1970	1980	1990	2000	
Anchor Point	S	20	65	171	102	226	866	1,845	113.0%
Grouse Creek	E	New					580	1,748	201.4%
Beluga	W	New						32	NA
Clam Gulch	C	0	0	0	47	50	79	173	119.0%
Cohoe	C	0	0	122	0	0	508	1,168	129.9%
Cooper Landing	S	0	60	130	31	116	243	369	51.9%
Crown Point	E	0	0	0	0	0	62	75	21.0%
Diamond Ridge	S	New						1,802	NA
Fox River	S	0	0	0	0	0	382	616	61.3%
Fritz Creek	S	0	0	0	27	404	1,426	1,603	12.4%
Funny River	C	New						636	NA
Halibut Cove	S	0	0	25	44	47	78	35	-55.1%
Happy Valley	S	0	0	0	0	0	309	489	58.3%
Homer	S	325	307	1,247	1,803	2,209	3,660	3,946	7.8%
Hope	E	71	63	44	51	103	161	137	-14.9%
Jakolof Bay	S	0	0	0	0	36	28	Discontinued	NA
Kachemak	S	0	0	0	76	301	365	431	18.1%
Kalifornsky	C	0	0	0	0	92	285	5,846	1951.2%
Kasilof	C	62	62	89	71	201	383	471	23.0%
Kenai	C	303	321	778	3,533	4,324	6,327	6,942	9.7%
Lowell Point	E	New						92	NA
Miller Landing	S	New						74	NA
Moose Pass	E	84	70	136	53	76	81	206	154.3%
Nanwalek	S	48	75	78	58	124	158	177	12.0%
Nikiski	C	0	0	0	0	1,109	2,743	4,327	57.7%
Nikolaevsk	S	0	0	0	0	0	371	345	-7.0%
Ninilchik	S	132	97	169	134	341	456	772	69.3%
Port Graham	S	93	92	139	107	161	166	171	3.0%
Primrose	E	0	0	0	0	0	63	93	47.6%
Ridgeway	C	0	0	0	0	0	2,018	1,932	-4.3%
Salamatof	C	0	0	0	0	334	999	954	-4.5%
Seldovia Village	S	410	437	460	437	479	459	144	-68.6%
Seldovia City	S	0	0	0	0	0	316	286	-9.5%
Seward	E	949	2,114	1,891	1,587	1,843	2,699	2,830	4.9%
Soldotna	C	0	0	32	1,202	2,320	3,482	3,759	8.0%
Sterling	C	0	0	115	30	919	3,802	4,705	23.8%
Sunrise	C	New						18	NA
Tyonek	W	136	132	187	232	239	154	193	25.3%
Remainder of Census area	E			2,956	2,337	9,228	7,409	249	-96.6%
Kenai Peninsula Borough		2,633	3,895	8,769	11,962	25,282	40,802	49,691	21.8%

Table 1.58

KPB Population

KPB Population and Housing Density - Census 2000							
	Population	Housing Units	Area in Square Miles			Density per Square Mile of land area	
			Total Area	Water Area	Land Area	Population	Housing Units
Anchor Point	1,845	979	90.9	0.12	90.79	20.3	10.8
Bear Creek	1,748	806	42.78	0.89	41.89	41.7	19.2
Beluga	32	54	103.38	0.74	102.65	0.3	0.5
Clam Gulch	173	115	13.73	0	13.73	12.6	8.4
Cohoe	1,168	630	72.63	2.9	69.73	16.7	9
Cooper Landing	369	379	69.91	3.92	66	5.6	6
Crown Point	75	38	3.55	0	3.55	21.1	11
Diamond Ridge	1,802	850	47.67	0.04	47.63	37.8	18
Fox River	616	170	129.44	2.85	126.59	4.9	1.3
Fritz Creek	1,603	854	54.4	0	54.4	29.5	15.7
Funny River	636	621	29.32	2.13	27.19	23.4	22.8
Halibut Cove	35	123	11.36	3.25	8.12	4.3	15.2
Happy Valley	489	398	88.65	0.07	88.58	5.5	4.5
Homer	3,946	1,873	22.43	11.85	10.58	372.9	177
Hope	137	175	51.79	0.08	51.7	2.6	3.4
Kachemak	431	219	1.61	0	1.61	268	136.2
Kalifornsky	5,846	2,479	70.15	0.96	69.19	84.5	35.8
Kasilof	471	208	10.57	0.21	10.36	45.4	20.1
Kenai	6,942	3,003	35.53	5.63	29.9	232.2	100.4
Lowell Point	92	72	11.78	0	11.77	7.8	6.1
Miller Landing	74	35	0.25	0	0.25	292.9	138.6
Moose Pass	206	119	18.1	0.06	18.04	11.4	6.6
Nanwalek	177	54	8.51	0	8.51	20.8	6.3
Nikiski	4,327	1,766	76.21	6.6	69.62	62.2	25.4
Nikolaevsk	345	122	36.27	0	36.27	9.5	3.4
Ninilchik	772	762	207.6	0.03	207.57	3.7	3.7
Port Graham	171	82	5.93	0	5.93	28.8	13.8
Primrose	93	47	38.37	0.97	37.39	2.5	1.3
Ridgeway	1,932	938	17.6	0.95	16.65	116.0	56.3
Salamatof	954	282	8.25	0.14	8.11	117.7	34.8
Seldovia City	286	232	0.57	0.19	0.38	749.9	608.3
Seldovia Village	144	159	20.83	1.01	19.82	7.3	8
Seward	2,830	1,058	21.53	7.09	14.44	196.0	73.3
Soldotna	3,759	1,670	7.41	0.47	6.94	541.9	240.7
Sterling	4,705	2,554	79.4	2.08	77.31	60.9	33
Sunrise	18	25	13.02	0	13.02	1.4	1.9
Tyonek	193	134	68.8	1.19	67.61	2.9	2
KPB Remainder	249	786	23,164.37	8,684.94	14,479.43	0.0	0.1
Kenai Peninsula Borough	49,691	24,871	24,754.60	8,741.34	16,013.26	3.1	1.6

Table 1.59

KPB Population

KPB Select Detail - 1990 v 2000

Population					Housing				
	1990	2000	Percent Change	Percent of Total		1990	2000	Percent Change	Percent of Total
Total Population	40,802	49,691	21.8%	100.0%	Total Households	14,250	18,438	29.4%	100.0%
Male	21,606	25,853	19.7%	52.0%	Family Households	10,216	12,716	24.5%	69.0%
Female	19,196	23,838	24.2%	48.0%	With Children Under 18	NA	7,003	NA	38.0%
Under 5 years	3,795	3,288	-13.4%	6.6%	Married Couple Family	8,456	10,218	20.8%	55.4%
5 to 9 years	4,104	4,024	-1.9%	8.1%	With Own Children Under 18	NA	5,133	NA	27.8%
10 to 14 years	3,505	4,698	34.0%	9.5%	Female Householder, no husband present	NA	1,654	NA	9.0%
15 to 19 years	2,939	4,140	40.9%	8.3%	With Own Children Under 18	NA	1,276	NA	6.9%
20 to 24 years	2,086	2,132	2.2%	4.3%	Average Household Size	2.79	2.62	-6.1%	0.0%
25 to 34 years	7,281	5,648	-22.4%	11.4%	Average Family Size	NA	3.15	NA	0.0%
35 to 44 years	8,229	9,074	10.3%	18.3%	Total Housing Units	19,364	24,871	NA	100.0%
45 to 54 years	4,280	8,739	104.2%	17.6%	Occupied Housing Units	14,250	18,438	29.4%	74.1%
55 to 59 years	1,387	2,632	89.8%	5.3%	Vacant Housing Units	5,114	6,433	25.8%	25.9%
60 to 64 years	1,181	1,667	41.2%	3.4%	Seasonal, Recreational, Occasional Use	2,819	4,560	61.8%	18.3%
65 to 74 years	1,503	2,361	57.1%	4.8%	Owner Vacancy Rate	4.1%	2.9%	NA	NA
75 to 84 years	431	1,077	149.9%	2.2%	Rental Vacancy Rate	13.9%	14.4%	NA	NA
85 years and over	81	211	160.5%	0.4%	Owner Occupied Units	9,677	13,585	40.4%	54.6%
Median Age	31.1	36.3	16.7%	NA	Renter Occupied Units	4,573	4,853	6.1%	19.5%
18 Years and Over	13,396	34,832	160.0%	70.1%	Marital Status (over 15)	NA	37,696	NA	100.0%
Male	NA	18,239	NA	36.7%	Never married	NA	8,829	NA	23.4%
Female	NA	16,593	NA	33.4%	Married except separated	NA	22,022	NA	58.4%
65 Years and Over	2,015	3,649	81.1%	7.3%	Separated	NA	698	NA	1.9%
Male	NA	1,765	NA	3.6%	Widowed	NA	1,330	NA	3.5%
Female	NA	1,884	NA	3.8%	Divorced	NA	4,817	NA	12.8%
Place of Birth					Disabled, Noninstitutionalized				
Native Born	39,726	48,335	21.7%	97.3%	Population 5 to 20	NA	13,244	NA	100.0%
Born in Alaska	NA	17,440	NA	35.1%	With a Disability	NA	842	NA	6.4%
Born in other state	NA	30,444	NA	61.3%	Population 21 to 64	NA	28,547	NA	100.0%
Foreign Born	1,076	1,356	26.0%	2.7%	With a Disability	NA	4,843	NA	17.0%
Naturalized Citizen	NA	872	NA	1.8%	Percent Employed	NA	45.4%	NA	45.4%
Not a Citizen	NA	484	NA	1.0%	Without a Disability	NA	23,704	NA	83.0%
Veteran Status					Percent Employed	NA	69.9%	NA	69.9%
Civilian veterans	5,335	5,941	11.4%	17.1%	Income in 1999 - Families				
Educational Attainment					Total Families - 12,736				
Population 25 years and over	Total 31,388				Less than \$10,000	604	602	-0.3%	4.7%
Less than 9th grade	934	985	5.5%	3.1%	\$10,000 - \$14,999	548	512	-6.6%	4.0%
9th-12th, no diploma	2,185	2,620	19.9%	8.3%	\$15,000 - \$24,999	1,177	1,248	6.0%	9.8%
High School Diploma	8,560	9,990	16.7%	31.8%	\$25,000 - \$34,999	1,151	1,396	21.3%	11.0%
College, no degree	6,581	9,492	44.2%	30.2%	\$35,000 - \$49,999	1,895	1,970	4.0%	15.5%
Associate Degree	1,789	1,939	8.4%	6.2%	\$50,000 - \$74,999	2,688	3,148	17.1%	24.7%
Bachelor's Degree	3,165	4,254	34.4%	13.6%	\$75,000 - \$99,999	1,361	1,855	36.3%	14.6%
Graduate, Profess Degree	1,209	2,108	74.4%	6.7%	\$100,000 - \$149,999	687	1,561	127.2%	12.3%
Percent HS Grad	87.2%	88.5%	1.5%	NA	\$150,000 - \$199,999	279	245	-12.2%	1.9%
Percent Bachelor's +	17.9%	20.3%	13.4%	NA	\$200,000 or more	NA	199	NA	1.6%
					Median Income - \$	48,339	54,106	11.9%	NA

Table 1.60

KPB Population

Population Projections

The Alaska Department of Labor projects population on five-year increments, and by several standards, for Alaska and the boroughs of Alaska. Each projection carries a high, low and middle amount. Data listed in the following tables reports the middle projected population for each year projected. Amounts are reported for Alaska, the KPB and for Anchorage in the following.

Population Projections through 2018							
	2003	2008	Change	2013	Change	2018	Change
Alaska	656,150	693,018	5.6%	733,852	5.9%	712,146	-3.0%
KPB	52,382	56,110	7.1%	60,234	7.3%	62,124	3.1%
Anchorage Muni	333,042	353,770	6.2%	376,779	6.5%	401,121	6.5%

Table 1.61

Projected Population with Components* of Change through 2018										
	2003	Natural Increase	Net Migration	2008	Natural Increase	Net Migration	2013	Natural Increase	Net Migration	2018
Alaska	656,150	37,130	-262	693,018	41,032	-198	733,852	42,791	-155	776,488
KPB	52,382	2,341	1,387	56,110	2,448	1,676	60,234	2,299	1,772	64,305
Anchorage Muni	269,567	14,777	-4,637	279,707	15,835	-6,014	289,528	16,409	-7,062	298,875

Table 1.62

* - Components are natural increase and net migration.

Projected Population Ages 5-17 through 2018							
	2003	2008	Change	2013	Change	2018	Change
Alaska	149,307	147,811	-1.0%	151,044	2.2%	163,411	8.2%
KPB	16,786	11,691	-30.4%	12,876	10.1%	14,642	13.7%
Anchorage Muni	60,261	57,465	-4.6%	54,651	-4.9%	55,017	0.7%

Table 1.63

Projected Population 16+ through 2018							
	2003	2008	Change	2013	Change	2018	Change
Alaska	478,033	513,290	7.4%	542,527	5.7%	567,703	4.6%
KPB	38,841	41,621	7.2%	43,950	5.6%	46,380	5.5%
Anchorage Muni	199,540	212,640	6.6%	222,991	4.9%	228,775	2.6%

Table 1.64

Projected Population 18+ through 2018							
	2003	2008	Change	2013	Change	2018	Change
Alaska	455,180	488,777	7.4%	519,343	6.3%	544,618	4.9%
KPB	36,939	39,696	7.5%	42,185	6.3%	44,277	5.0%
Anchorage Muni	190,555	202,668	6.4%	213,223	5.2%	220,596	3.5%

Table 1.65

Projected Population 65+ through 2018							
	2003	2008	Change	2013	Change	2018	Change
Alaska	40,379	52,298	29.5%	69,555	33.0%	93,272	34.1%
KPB	3,904	5,022	28.6%	6,797	35.3%	9,410	38.4%
Anchorage Muni	16,146	21,134	30.9%	28,056	32.8%	36,473	30.0%

Table 1.66

KPB Population



Homer Sales

Homer 3rd Quarter GROSS Sales by Industry - 1999-2005 - in \$								
	1999	2000	2001	2002	2003	2004	2005	Annual Change
AFF	271,045	617,216	369,625	358,911	485,712	512,372	604,181	17.9%
Min	13,400	23,747	4,209	3,383	448	695	582	-16.3%
Const	7,328,638	13,266,938	13,713,481	15,972,357	11,629,038	9,736,168	12,484,533	28.2%
Manu	6,232,592	1,509,013	1,967,400	2,153,455	2,019,280	1,752,124	1,877,850	7.2%
TCPU	9,083,098	9,917,768	12,698,696	11,525,181	11,335,988	13,967,425	14,428,731	3.3%
Whole	5,492,391	5,604,085	6,252,096	6,595,619	6,629,440	7,325,763	7,691,969	5.0%
Retail	21,600,116	22,996,502	24,152,918	28,967,558	31,205,896	34,477,697	36,092,714	4.7%
FIRE	1,926,974	1,960,065	2,278,077	2,696,231	2,825,493	3,341,741	3,259,352	-2.5%
Service	14,404,867	14,114,334	16,017,454	21,417,906	21,072,697	22,821,410	23,334,703	2.2%
Govt	0	0	0	0	0	0	0	0.0%
Total	66,353,121	70,009,668	77,453,956	89,690,601	87,203,992	93,935,395	99,774,615	6.2%
Annual Change		5.5%	10.6%	15.8%	-2.8%	7.7%	6.2%	

Table 2.1

Homer 3rd Quarter GROSS Sales Ten Year Change by INDUSTRY - 1995 v. 2005 - in \$				
			10 Year Change	
	1995	2005	Percentage	Numerical
AFF	233,940	604,181	158.3%	370,241
Min	1,583	582	-63.2%	-1,001
Const	8,751,295	12,484,533	42.7%	3,733,238
Manu	12,600,957	1,877,850	-85.1%	-10,723,107
TCPU	7,973,988	14,428,731	80.9%	6,454,743
Whole	4,788,633	7,691,969	60.6%	2,903,336
Retail	18,948,533	36,092,714	90.5%	17,144,181
FIRE	1,689,991	3,259,352	92.9%	1,569,361
Service	11,570,636	23,334,703	101.7%	11,764,067
Govt	0	0	0.0%	0
Total	66,559,556	99,774,615	49.9%	33,215,059

Table 2.2

Homer 3rd Quarter GROSS Sales One Year Change by INDUSTRY - 2004 v. 2005 - in \$				
			1 Year Change	
	2004	2005	Percentage	Numerical
AFF	512,372	604,181	17.9%	91,809
Min	695	582	-16.3%	-113
Const	9,736,168	12,484,533	28.2%	2,748,365
Manu	1,752,124	1,877,850	7.2%	125,726
TCPU	13,967,425	14,428,731	3.3%	461,306
Whole	7,325,763	7,691,969	5.0%	366,206
Retail	34,477,697	36,092,714	4.7%	1,615,017
FIRE	3,341,741	3,259,352	-2.5%	-82,389
Service	22,821,410	23,334,703	2.2%	513,293
Govt	0	0	0.0%	0
Total	93,935,395	99,774,615	6.2%	5,839,220

Table 2.3

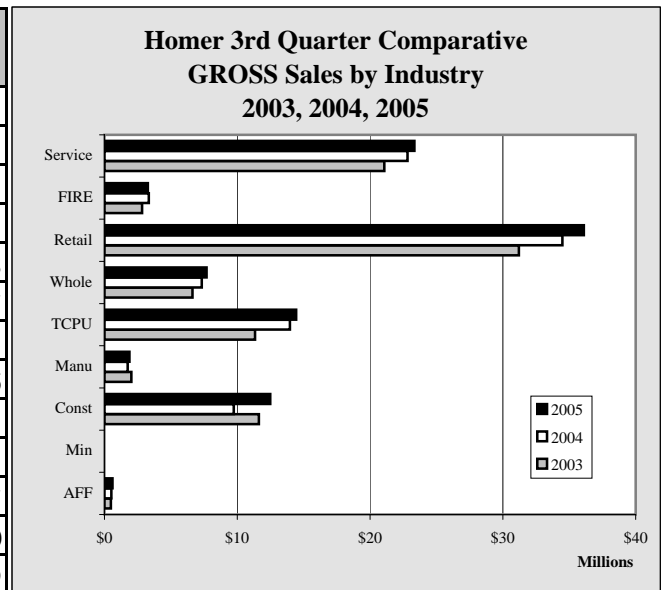

Chart 2.1

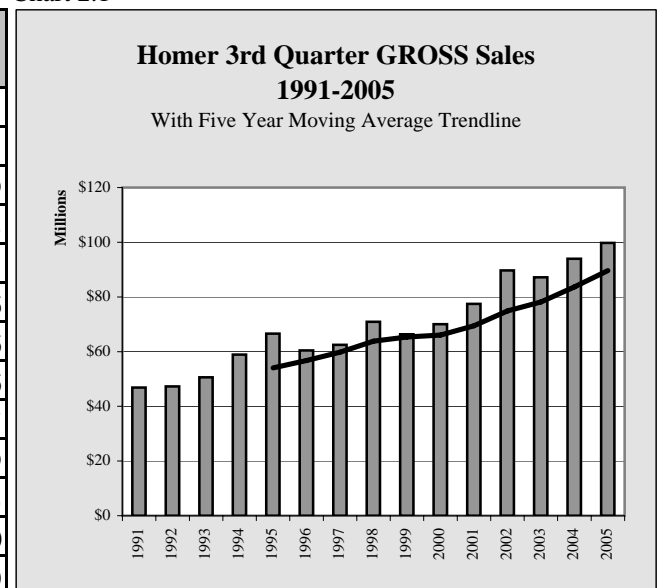

Chart 2.2

Homer Sales

Homer 3rd Quarter TAXABLE Sales by Industry - 1999-2005 - in \$							
	1999	2000	2001	2002	2003	2004	2005
AFF	146,340	149,462	177,823	195,905	250,473	305,982	289,599
Min	0	500	2,175	0	0	0	0
Const	223,001	239,938	280,862	324,412	335,295	300,979	355,027
Manu	619,889	588,489	525,720	597,126	618,081	632,048	577,480
TCPU	2,999,198	3,098,352	3,245,406	3,752,729	3,752,532	3,909,932	3,926,542
Whole	2,550,653	2,803,690	2,883,405	2,928,198	3,370,701	3,998,096	3,606,796
Retail	16,429,320	17,384,695	18,278,875	21,308,629	22,642,061	24,233,534	25,515,618
FIRE	848,368	921,668	1,006,507	1,165,651	1,146,791	1,453,205	1,352,922
Service	10,430,960	10,490,417	11,173,929	12,978,461	12,988,299	14,193,603	14,248,055
Govt	0	0	0	0	0	0	0
Total	34,247,729	35,677,211	37,574,702	43,251,111	45,104,233	49,027,379	49,872,039
Annual Change		4.2%	5.3%	15.1%	4.3%	8.7%	1.7%

Table 2.4

Homer 3rd Quarter TAXABLE Sales Ten Year Change by INDUSTRY - 1995 v. 2005 - in \$				
	10 Year Change			
	1995	2005	Percentage	Numerical
AFF	164,655	289,599	75.9%	124,944
Min	500	0	-100.0%	-500
Const	199,159	355,027	78.3%	155,868
Manu	641,456	577,480	-10.0%	-63,976
TCPU	2,493,523	3,926,542	57.5%	1,433,019
Whole	2,482,414	3,606,796	45.3%	1,124,382
Retail	14,753,692	25,515,618	72.9%	10,761,926
FIRE	966,302	1,352,922	40.0%	386,620
Service	8,696,461	14,248,055	63.8%	5,551,594
Govt	0	0	0.0%	0
Total	30,398,162	49,872,039	64.1%	19,473,877

Table 2.5

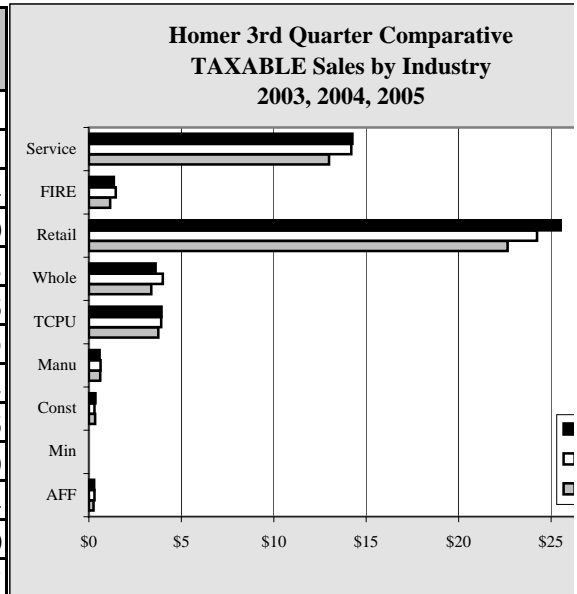

Chart 2.3

Homer 3rd Quarter TAXABLE Sales One Year Change by INDUSTRY - 2004 v. 2005 - in \$				
	1 Year Change			
	2004	2005	Percentage	Numerical
AFF	305,982	289,599	-5.4%	-16,383
Min	0	0	0.0%	0
Const	300,979	355,027	18.0%	54,048
Manu	632,048	577,480	-8.6%	-54,568
TCPU	3,909,932	3,926,542	0.4%	16,610
Whole	3,998,096	3,606,796	-9.8%	-391,300
Retail	24,233,534	25,515,618	5.3%	1,282,084
FIRE	1,453,205	1,352,922	-6.9%	-100,283
Service	14,193,603	14,248,055	0.4%	54,452
Govt	0	0	0.0%	0
Total	49,027,379	49,872,039	1.7%	844,660

Table 2.6

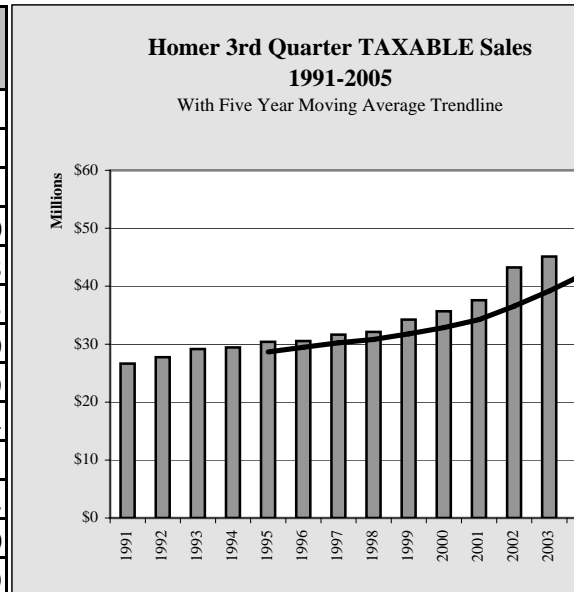
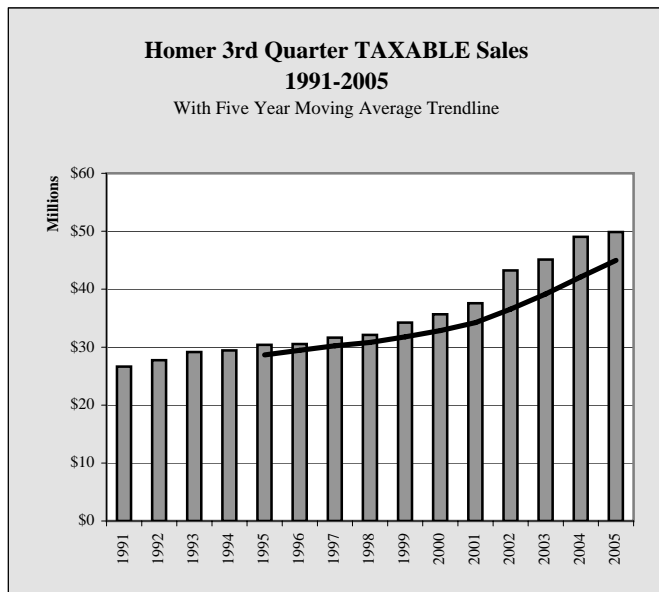
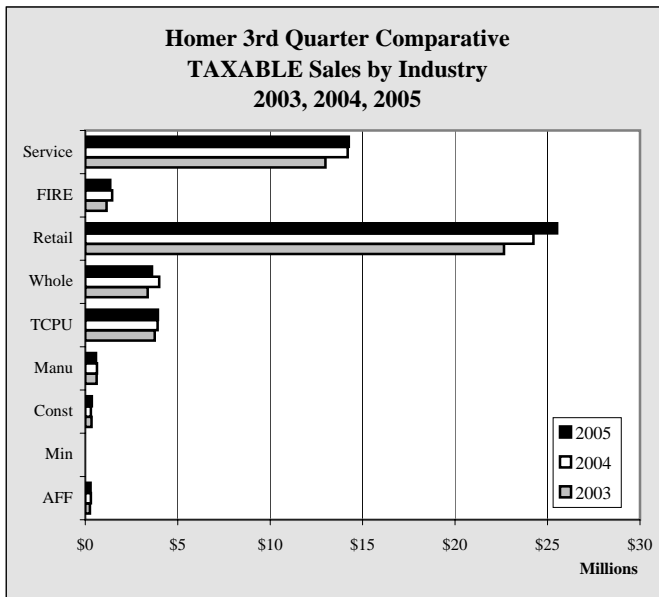

Chart 2.4

Homer Sales

Annual Change
-5.4%
NA
18.0%
-8.6%
0.4%
-9.8%
5.3%
-6.9%
0.4%
0.0%
1.7%



Homer Sales

Homer YTD 9/30 GROSS Sales by Industry - 1999-2005 - in \$

	1999	2000	2001	2002	2003	2004	2005	Annual Change
AFF	662,392	1,407,492	751,448	744,012	1,155,191	1,171,819	1,399,152	19.4%
Min	13,595	23,747	15,190	8,582	448	1,055	15,992	1415.8%
Const	19,217,701	32,370,872	28,564,046	31,841,012	32,495,599	19,747,683	29,224,522	48.0%
Manu	14,480,398	5,201,883	4,747,986	5,197,710	5,236,851	4,675,914	4,232,405	-9.5%
TCPU	25,636,218	26,264,813	30,018,520	32,291,566	30,575,179	35,750,315	37,757,571	5.6%
Whole	14,235,936	13,233,736	14,956,778	15,313,761	16,766,848	17,869,672	19,306,818	8.0%
Retail	51,215,265	55,085,151	58,054,191	67,732,439	75,872,385	82,726,530	88,293,496	6.7%
FIRE	5,801,863	5,093,780	5,665,391	6,270,545	7,363,162	8,208,409	8,098,348	-1.3%
Service	28,514,589	29,070,943	32,382,859	43,227,665	44,254,549	47,677,404	49,495,513	3.8%
Govt	0	0	0	0	0	394	0	NA
Total	159,777,957	167,752,417	175,156,409	202,627,292	213,720,212	217,829,195	237,823,817	9.2%
Annual Change		5.0%	4.4%	15.7%	5.5%	1.9%	9.2%	

Table 2.7

**Homer YTD 9/30 GROSS Sales Ten Year Change
by INDUSTRY - 1995 v. 2005 - in \$**

	1995	2005	10 Year Change	
			Percentage	Numerical
AFF	511,696	1,399,152	173.4%	887,456
Min	1,670	15,992	857.6%	14,322
Const	14,267,079	29,224,522	104.8%	14,957,443
Manu	25,453,383	4,232,405	-83.4%	-21,220,978
TCPU	21,657,962	37,757,571	74.3%	16,099,609
Whole	11,939,932	19,306,818	61.7%	7,366,886
Retail	45,057,146	88,293,496	96.0%	43,236,350
FIRE	4,398,661	8,098,348	84.1%	3,699,687
Service	23,558,479	49,495,513	110.1%	25,937,034
Govt	0	0	0.0%	0
Total	146,846,008	237,823,817	62.0%	90,977,809

Table 2.8

**Homer YTD 9/30 Comparative
GROSS Sales by Industry
2003, 2004, 2005**

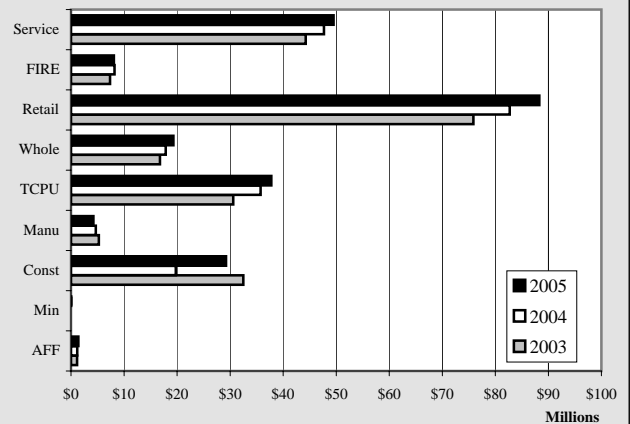

Chart 2.5

**Homer YTD 9/30 GROSS Sales One Year Change
by INDUSTRY - 2004 v. 2005 - in \$**

	2004	2005	1 Year Change	
			Percentage	Numerical
AFF	1,171,819	1,399,152	19.4%	227,333
Min	1,055	15,992	0.0%	14,937
Const	19,747,683	29,224,522	48.0%	9,476,839
Manu	4,675,914	4,232,405	-9.5%	-443,509
TCPU	35,750,315	37,757,571	5.6%	2,007,256
Whole	17,869,672	19,306,818	8.0%	1,437,146
Retail	82,726,530	88,293,496	6.7%	5,566,966
FIRE	8,208,409	8,098,348	-1.3%	-110,061
Service	47,677,404	49,495,513	3.8%	1,818,109
Govt	394	0	-100.0%	-394
Total	217,829,195	237,823,817	9.2%	19,994,622

Table 2.9

**Homer YTD 9/30 GROSS Sales
1991-2005
With Five Year Moving Average Trendline**

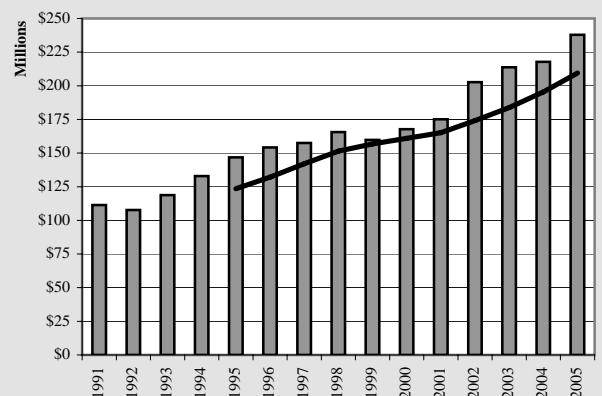

Chart 2.6

Homer Sales

Homer YTD 9/30 TAXABLE Sales by Industry - 1999-2005 - in \$								
	1999	2000	2001	2002	2003	2004	2005	Annual Change
AFF	345,718	392,441	432,147	480,160	598,746	711,569	719,080	1.1%
Min	195	500	5,364	2,665	0	104	0	NA
Const	648,667	678,257	677,038	829,040	891,291	897,183	870,403	-3.0%
Manu	1,594,218	1,545,881	1,379,972	1,417,473	1,428,073	1,545,433	1,313,605	-15.0%
TCPU	7,872,654	7,888,296	7,956,118	8,850,894	9,856,122	9,964,635	10,021,110	0.6%
Whole	6,197,645	6,880,881	7,113,752	7,108,879	8,347,761	9,553,311	9,155,531	-4.2%
Retail	39,060,200	41,471,887	43,689,648	49,656,600	54,403,653	58,480,170	61,717,232	5.5%
FIRE	2,261,268	2,411,275	2,622,360	2,939,956	3,109,546	3,497,080	3,288,047	-6.0%
Service	19,844,190	20,533,525	21,654,984	24,930,037	25,963,791	27,850,944	28,577,717	2.6%
Govt	0	0	0	0	0	394	0	NA
Total	77,824,755	81,802,943	85,531,383	96,215,704	104,598,983	112,500,823	115,662,725	2.8%
Annual Change		5.1%	4.6%	12.5%	8.7%	7.6%	2.8%	

Table 2.10

Homer YTD 9/30 TAXABLE Sales Ten Year Change by INDUSTRY - 1995 v. 2005 - in \$				
	10 Year Change			
	1995	2005	Percentage	Numerical
AFF	362,015	719,080	98.6%	357,065
Min	500	0	-100.0%	-500
Const	624,772	870,403	39.3%	245,631
Manu	1,647,803	1,313,605	-20.3%	-334,198
TCPU	6,334,521	10,021,110	58.2%	3,686,589
Whole	6,074,775	9,155,531	50.7%	3,080,756
Retail	35,434,115	61,717,232	74.2%	26,283,117
FIRE	2,413,215	3,288,047	36.3%	874,832
Service	17,205,052	28,577,717	66.1%	11,372,665
Govt	0	0	0.0%	0
Total	70,096,768	115,662,725	65.0%	45,565,957

Table 2.11

Homer YTD 9/30 TAXABLE Sales One Year Change by INDUSTRY - 2004 v. 2005 - in \$				
	1 Year Change			
	2004	2005	Percentage	Numerical
AFF	711,569	719,080	1.1%	7,511
Min	104	0	0.0%	-104
Const	897,183	870,403	-3.0%	-26,780
Manu	1,545,433	1,313,605	-15.0%	-231,828
TCPU	9,964,635	10,021,110	0.6%	56,475
Whole	9,553,311	9,155,531	-4.2%	-397,780
Retail	58,480,170	61,717,232	5.5%	3,237,062
FIRE	3,497,080	3,288,047	-6.0%	-209,033
Service	27,850,944	28,577,717	2.6%	726,773
Govt	394	0	-100.0%	-394
Total	112,500,823	115,662,725	2.8%	3,161,902

Table 2.12

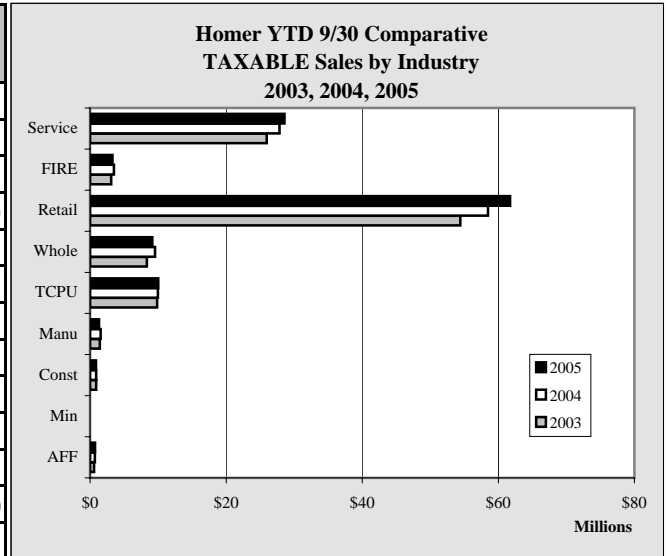

Chart 2.7

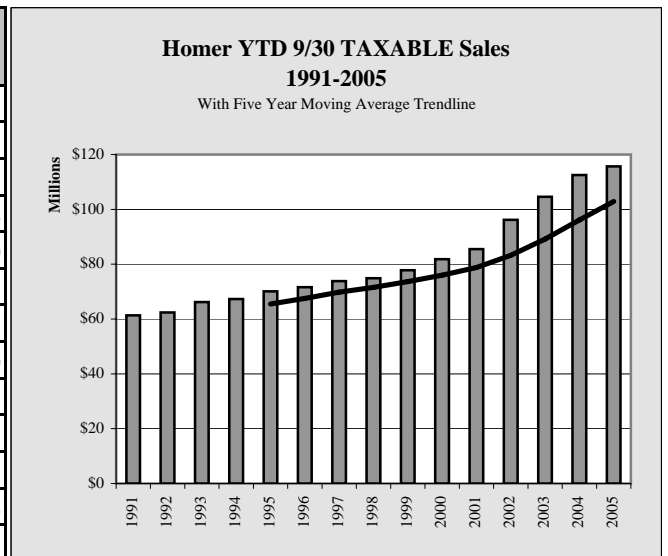

Chart 2.8

Homer Sales

Homer Annual GROSS Sales by Industry - 1998-2004 - in \$

	1998	1999	2000	2001	2002	2003	2004	Annual Change
AFF	1,231,758	1,132,289	1,763,891	931,926	1,013,352	1,592,413	1,520,013	-4.5%
Min	130	13,595	24,864	15,819	8,582	1,283	151,171	11682.6%
Const	37,787,332	27,642,104	42,378,954	40,149,696	45,829,436	41,984,440	32,449,476	-22.7%
Manu	19,649,701	16,450,883	6,761,789	6,482,895	6,590,594	6,755,907	5,657,729	-16.3%
TCPU	34,491,856	33,675,536	34,493,682	40,495,596	42,137,752	39,996,686	47,283,230	18.2%
Whole	14,672,913	17,513,809	16,999,389	18,602,483	19,915,750	22,075,685	27,077,381	22.7%
Retail	64,712,270	66,221,369	71,465,479	75,795,576	88,239,711	97,820,663	105,673,533	8.0%
FIRE	8,574,588	7,448,936	6,682,678	7,544,432	8,453,334	9,936,484	11,521,431	16.0%
Service	31,322,069	33,743,954	35,410,998	39,685,084	51,007,289	53,885,292	59,120,041	9.7%
Govt	0	0	0	0	0	263	394	49.8%
Total	212,442,617	203,842,475	215,981,724	229,703,507	263,195,800	274,049,116	290,454,399	6.0%
Annual Change		-4.0%	6.0%	6.4%	14.6%	4.1%	6.0%	

Table 2.13

**Homer Annual GROSS Sales Ten Year Change
by INDUSTRY - 1994 v. 2004 - in \$**

	1994	2004	10 Year Change	
			Percentage	Numerical
AFF	1,222,880	1,520,013	24.3%	297,133
Min	330	151,171	45709.4%	150,841
Const	16,232,990	32,449,476	99.9%	16,216,486
Manu	21,881,742	5,657,729	-74.1%	-16,224,013
TCPU	27,566,951	47,283,230	71.5%	19,716,279
Whole	16,824,829	27,077,381	60.9%	10,252,552
Retail	53,704,143	105,673,533	96.8%	51,969,390
FIRE	5,794,509	11,521,431	98.8%	5,726,922
Service	27,863,995	59,120,041	112.2%	31,256,046
Govt	0	394	0.0%	394
Total	171,092,369	290,454,399	69.8%	119,362,030

Table 2.14

**Homer Annual GROSS Sales One Year Change
by INDUSTRY - 2003 v. 2004 - in \$**

	2003	2004	1 Year Change	
			Percentage	Numerical
AFF	1,592,413	1,520,013	-4.5%	-72,400
Min	1,283	151,171	0.0%	149,888
Const	41,984,440	32,449,476	-22.7%	-9,534,964
Manu	6,755,907	5,657,729	-16.3%	-1,098,178
TCPU	39,996,686	47,283,230	18.2%	7,286,544
Whole	22,075,685	27,077,381	22.7%	5,001,696
Retail	97,820,663	105,673,533	8.0%	7,852,870
FIRE	9,936,484	11,521,431	16.0%	1,584,947
Service	53,885,292	59,120,041	9.7%	5,234,749
Govt	263	394	49.8%	131
Total	274,049,116	290,454,399	6.0%	16,405,283

Table 2.15

**Homer Annual Comparative
GROSS Sales by Industry
2002, 2003, 2004**

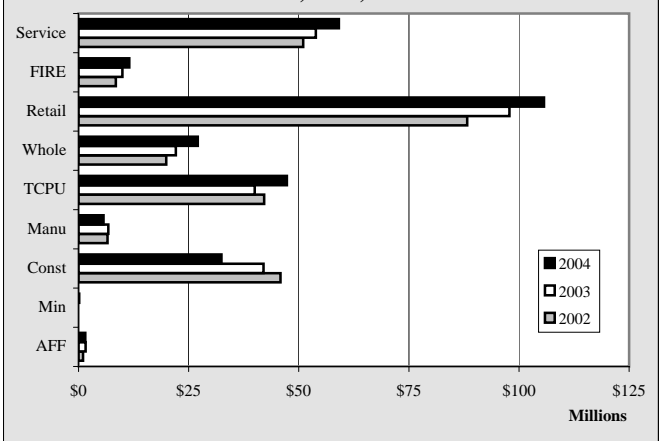

Chart 2.9

**Homer Annual GROSS Sales
1991-2004
With Five Year Moving Average Trendline**

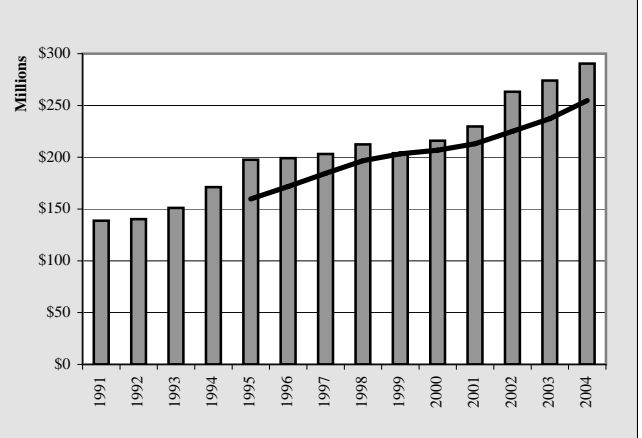

Chart 2.10

Homer Sales

Homer Annual TAXABLE Sales by Industry - 1998-2004 - in \$								
	1998	1999	2000	2001	2002	2003	2004	Annual Change
AFF	626,058	461,892	519,595	577,360	641,294	773,421	912,356	18.0%
Min	130	195	1,104	5,993	2,665	347	104	-70.0%
Const	820,655	891,101	891,188	940,211	1,125,715	1,208,909	1,182,169	-2.2%
Manu	2,087,103	2,084,079	2,045,894	1,769,534	1,822,345	1,848,166	1,857,314	0.5%
TCPU	9,578,082	10,137,988	10,110,454	10,200,922	11,698,087	12,717,059	12,827,427	0.9%
Whole	7,485,103	8,034,552	8,633,107	8,953,325	8,876,648	10,611,085	11,951,881	12.6%
Retail	48,994,370	50,357,048	53,206,860	56,027,806	63,864,887	69,823,667	74,188,687	6.3%
FIRE	2,814,367	2,949,461	3,147,793	3,460,712	3,890,685	4,074,657	4,455,978	9.4%
Service	22,035,474	23,232,422	24,634,121	25,375,676	29,345,792	30,646,956	32,622,727	6.4%
Govt	0	0	0	0	0	263	394	49.8%
Total	94,441,342	98,148,738	103,190,116	107,311,539	121,268,118	131,704,530	139,999,037	6.3%
Annual Change		3.9%	5.1%	4.0%	13.0%	8.6%	6.3%	

Table 2.16

Homer Annual TAXABLE Sales Ten Year Change by INDUSTRY - 1994 v. 2004 - in \$				
			10 Year Change	
	1994	2004	Percentage	Numerical
AFF	559,816	912,356	63.0%	352,540
Min	71	104	46.5%	33
Const	837,147	1,182,169	41.2%	345,022
Manu	1,899,920	1,857,314	-2.2%	-42,606
TCPU	7,914,816	12,827,427	62.1%	4,912,611
Whole	7,630,601	11,951,881	56.6%	4,321,280
Retail	42,860,842	74,188,687	73.1%	31,327,845
FIRE	3,022,085	4,455,978	47.4%	1,433,893
Service	19,320,160	32,622,727	68.9%	13,302,567
Govt	0	394	0.0%	394
Total	84,045,458	139,999,037	66.6%	55,953,579

Table 2.17

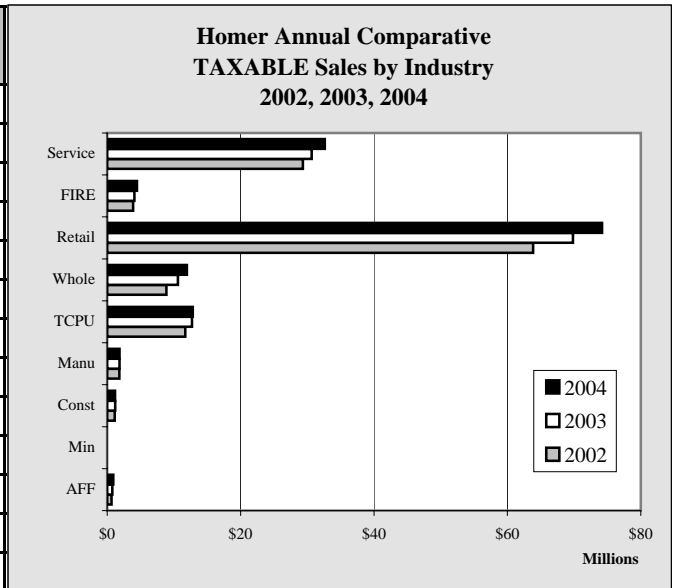

Chart 2.11

Homer Annual TAXABLE Sales One Year Change by INDUSTRY - 2003 v. 2004 - in \$				
			1 Year Change	
	2003	2004	Percentage	Numerical
AFF	773,421	912,356	18.0%	138,935
Min	347	104	0.0%	-243
Const	1,208,909	1,182,169	-2.2%	-26,740
Manu	1,848,166	1,857,314	0.5%	9,148
TCPU	12,717,059	12,827,427	0.9%	110,368
Whole	10,611,085	11,951,881	12.6%	1,340,796
Retail	69,823,667	74,188,687	6.3%	4,365,020
FIRE	4,074,657	4,455,978	9.4%	381,321
Service	30,646,956	32,622,727	6.4%	1,975,771
Govt	263	394	49.8%	131
Total	131,704,530	139,999,037	6.3%	8,294,507

Table 2.18

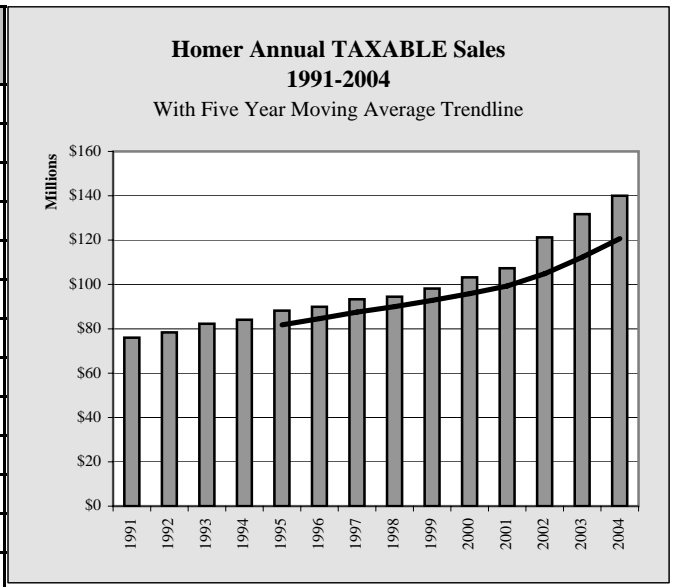

Chart 2.12

Homer Sales

Homer GROSS Sales by Industry by Quarter - 2002-2005 - in \$					
	1st Quarter	2nd Quarter	3rd Quarter	4th Quarter	Total
2002					
AFF	134,712	250,389	358,911	269,340	1,013,352
Min	1,363	3,836	3,383	0	8,582
Const	8,430,924	7,437,731	15,972,357	13,988,424	45,829,436
Manu	1,253,834	1,790,421	2,153,455	1,392,884	6,590,594
TCPU	9,784,288	10,982,097	11,525,181	9,846,186	42,137,752
Whole	3,358,010	5,360,132	6,595,619	4,601,989	19,915,750
Retail	13,767,872	24,997,009	28,967,558	20,507,272	88,239,711
FIRE	1,527,725	2,046,589	2,696,231	2,182,789	8,453,334
Service	6,006,218	15,803,541	21,417,906	7,779,624	51,007,289
Govt	0	0	0	0	0
Total	44,264,946	68,671,745	89,690,601	60,568,508	263,195,800
2003					
AFF	249,333	420,146	485,712	437,222	1,592,413
Min	0	0	448	835	1,283
Const	9,795,523	11,071,038	11,629,038	9,488,841	41,984,440
Manu	1,317,636	1,899,935	2,019,280	1,519,056	6,755,907
TCPU	9,460,657	9,778,534	11,335,988	9,421,507	39,996,686
Whole	4,044,595	6,092,813	6,629,440	5,308,837	22,075,685
Retail	17,108,705	27,557,784	31,205,896	21,948,278	97,820,663
FIRE	1,989,925	2,547,744	2,825,493	2,573,322	9,936,484
Service	7,261,902	15,919,950	21,072,697	9,630,743	53,885,292
Govt	0	0	0	263	263
Total	51,228,276	75,287,944	87,203,992	60,328,641	274,048,853
2004					
AFF	229,352	430,095	512,372	348,194	1,520,013
Min	256	104	695	150,116	151,171
Const	4,325,965	5,685,550	9,736,168	12,701,793	32,449,476
Manu	1,116,143	1,807,647	1,752,124	981,815	5,657,729
TCPU	9,977,448	11,805,442	13,967,425	11,532,915	47,283,230
Whole	4,122,172	6,421,737	7,325,763	9,207,709	27,077,381
Retail	18,227,417	30,021,416	34,477,697	22,947,003	105,673,533
FIRE	2,247,358	2,619,310	3,341,741	3,313,022	11,521,431
Service	7,895,081	16,960,913	22,821,410	11,442,637	59,120,041
Govt	394	0	0	0	394
Total	48,141,586	75,752,214	93,935,395	72,625,204	290,454,399
2005					
AFF	272,277	522,694	604,181		1,399,152
Min	0	15,410	582		15,992
Const	5,255,340	11,484,649	12,484,533		29,224,522
Manu	764,355	1,590,200	1,877,850		4,232,405
TCPU	10,860,964	12,467,876	14,428,731		37,757,571
Whole	4,480,452	7,134,397	7,691,969		19,306,818
Retail	19,799,137	32,401,645	36,092,714		88,293,496
FIRE	2,073,521	2,765,475	3,259,352		8,098,348
Service	8,374,589	17,786,221	23,334,703		49,495,513
Govt	0	0	0		0
Total	51,880,635	86,168,567	99,774,615		237,823,817

Table 2.19

Homer Sales

Homer TAXABLE Sales by Industry by Quarter - 2002-2005 - i				
	1st Quarter	2nd Quarter	3rd Quarter	4th Quarter
2002				
AFF	117,273	166,982	195,905	161,134
Min	710	1,955	0	0
Const	237,634	266,994	324,412	296,675
Manu	263,252	557,095	597,126	404,872
TCPU	2,225,122	2,873,043	3,752,729	2,847,193
Whole	1,662,455	2,518,226	2,928,198	1,767,769
Retail	10,100,688	18,247,283	21,308,629	14,208,287
FIRE	768,568	1,005,737	1,165,651	950,729
Service	3,321,402	8,630,174	12,978,461	4,415,755
Govt	0	0	0	0
Total	18,697,104	34,267,489	43,251,111	25,052,414
2003				
AFF	135,734	212,539	250,473	174,675
Min	0	0	0	347
Const	243,346	312,650	335,295	317,618
Manu	277,526	532,466	618,081	420,093
TCPU	2,890,615	3,212,975	3,752,532	2,860,937
Whole	2,010,808	2,966,252	3,370,701	2,263,324
Retail	11,998,705	19,762,887	22,642,061	15,420,014
FIRE	900,146	1,062,609	1,146,791	965,111
Service	3,999,402	8,976,090	12,988,299	4,683,165
Govt	0	0	0	263
Total	22,456,282	37,038,468	45,104,233	27,105,284
2004				
AFF	157,957	247,630	305,982	200,787
Min	0	104	0	0
Const	276,885	319,319	300,979	284,986
Manu	305,351	608,034	632,048	311,881
TCPU	2,806,506	3,248,197	3,909,932	2,862,792
Whole	2,234,379	3,320,836	3,998,096	2,398,570
Retail	12,978,758	21,267,878	24,233,534	15,708,517
FIRE	890,553	1,153,322	1,453,205	958,898
Service	4,174,137	9,483,204	14,193,603	4,771,783
Govt	394	0	0	0
Total	23,824,526	39,648,524	49,027,379	27,498,214
2005				
AFF	189,282	240,199	289,599	
Min	0	0	0	
Const	237,642	277,734	355,027	
Manu	221,919	514,206	577,480	
TCPU	2,820,114	3,274,454	3,926,542	
Whole	2,185,916	3,362,819	3,606,796	
Retail	13,489,044	22,712,570	25,515,618	
FIRE	853,085	1,082,040	1,352,922	
Service	4,330,176	9,999,486	14,248,055	
Govt	0	0	0	
Total	24,327,178	41,463,508	49,872,039	0

Table 2.20

Homer Sales

in \$
Total
641,294
2,665
1,125,715
1,822,345
11,698,087
8,876,648
63,864,887
3,890,685
29,345,792
0
121,268,118
773,421
347
1,208,909
1,848,166
12,717,059
10,611,085
69,823,667
4,074,657
30,646,956
263
131,704,267
912,356
104
1,182,169
1,857,314
12,827,427
11,951,881
74,188,687
4,455,978
32,622,727
394
139,998,643
Year to Date
719,080
0
870,403
1,313,605
10,021,110
9,155,531
61,717,232
3,288,047
28,577,717
0
115,662,725

Homer Construction Permitting

Homer 3rd Quarter Permit VALUES by Type - 1999-2005 - in \$								
	1999	2000	2001	2002	2003	2004	2005	Annual Change
Residential New	740,000	1,025,000	1,161,680	1,466,300	2,106,275	1,225,600	1,558,500	27.2%
Residential Alter/Add	199,000	109,560	122,720	217,940	285,000	851,300	364,000	-57.2%
Commercial New	4,800,000	805,000	340,000	3,912,740	628,800	6,225,000	2,240,000	-64.0%
Commercial Alter/Add	6,000	207,410	1,371,950	180,350	0	1,230,000	150,000	-87.8%
Total	5,745,000	2,146,970	2,996,350	5,777,330	3,020,075	9,531,900	4,312,500	-54.8%
Annual Change		-62.6%	39.6%	92.8%	-47.7%	215.6%	-54.8%	

Table 2.21

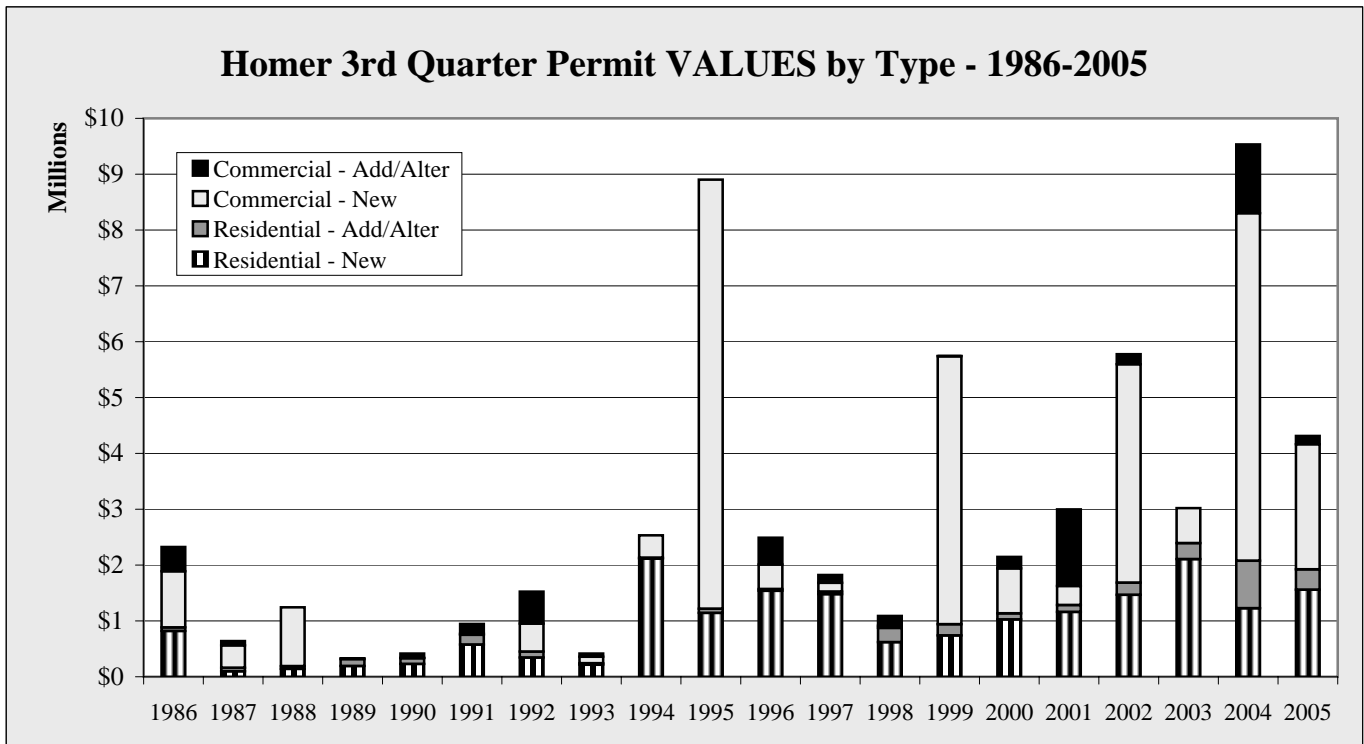

Chart 2.13

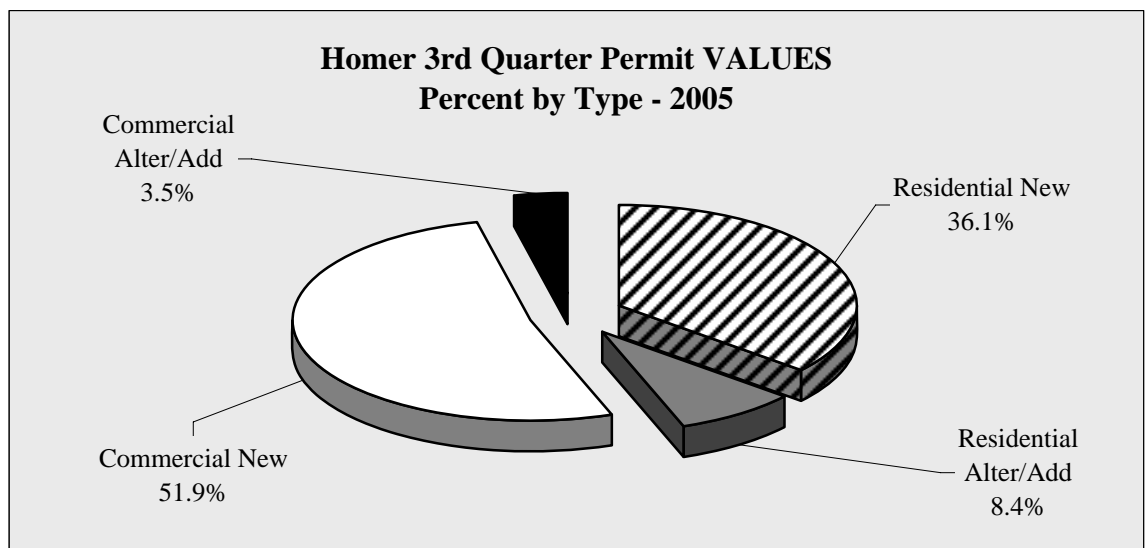

Chart 2.14

Homer Construction Permitting

Homer 3rd Quarter Permit VOLUME by Type - 1999-2005

	1999	2000	2001	2002	2003	2004	2005	Annual Change
Residential New	6	8	9	10	15	9	14	55.6%
Residential Alter/Add	11	5	4	8	3	21	8	-61.9%
Commercial New	2	2	2	6	3	8	2	-75.0%
Commercial Alter/Add	1	6	7	3	0	4	3	-25.0%
Total	20	21	22	27	21	42	27	-35.7%
Annual Change		5.0%	4.8%	22.7%	-22.2%	100.0%	-35.7%	

Table 2.22

Homer 3rd Quarter Permit VOLUME by Type - 1986-2005

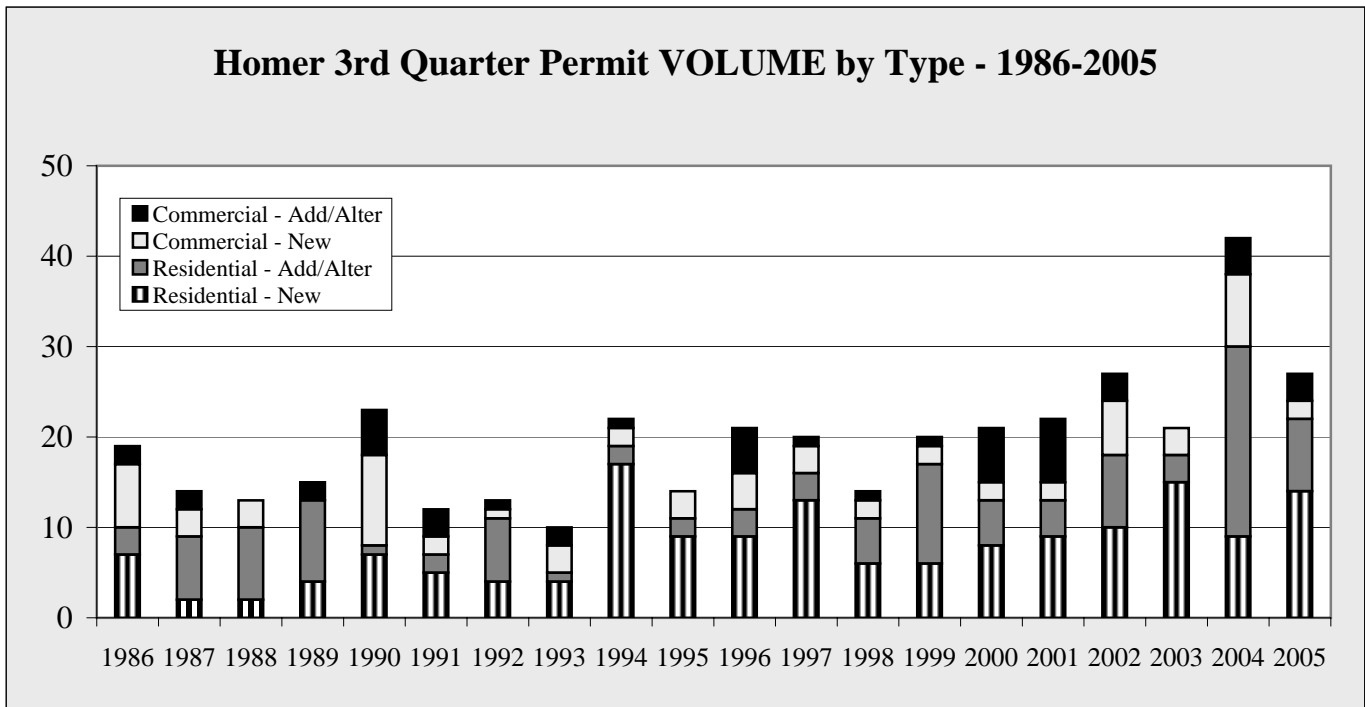

Chart 2.15

**Homer 3rd Quarter Permit VOLUME
Percent by Type - 2005**

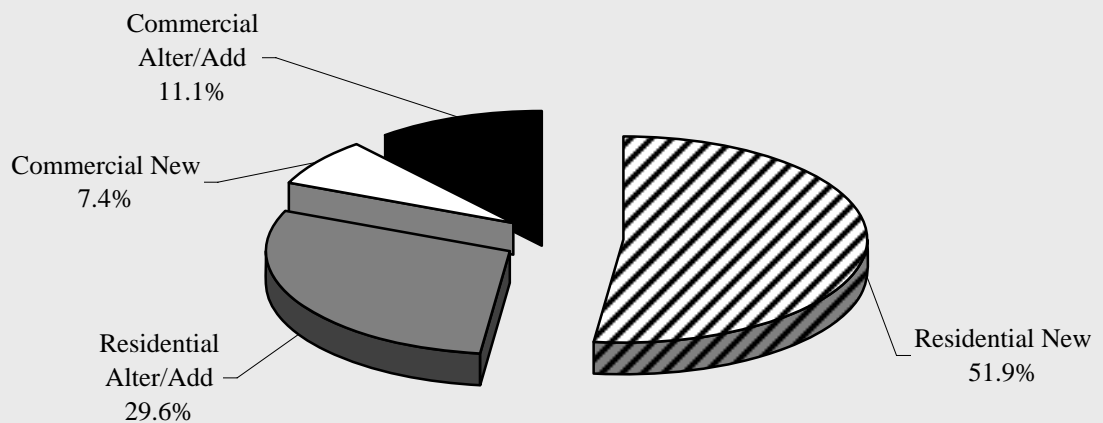

Chart 2.16

Homer Construction Permitting

Homer YTD 9/30 Permit VALUES by Type - 1999-2005 - in \$								
	1999	2000	2001	2002	2003	2004	2005	Annual Change
Residential New	3,451,000	2,285,040	3,555,480	3,666,520	6,897,555	6,318,500	6,324,900	0.1%
Residential Alter/Add	317,000	230,060	489,160	432,300	756,600	1,258,550	816,500	-35.1%
Commercial New	6,590,000	1,615,480	2,110,800	4,912,740	4,164,520	11,840,518	9,817,000	-17.1%
Commercial Alter/Add	21,000	2,080,410	1,632,950	222,699	465,240	1,262,063	1,702,000	34.9%
Total	10,379,000	6,210,990	7,788,390	9,234,259	12,283,915	20,679,631	18,660,400	-9.8%
Annual Change		-40.2%	25.4%	18.6%	33.0%	68.3%	-9.8%	

Table 2.23

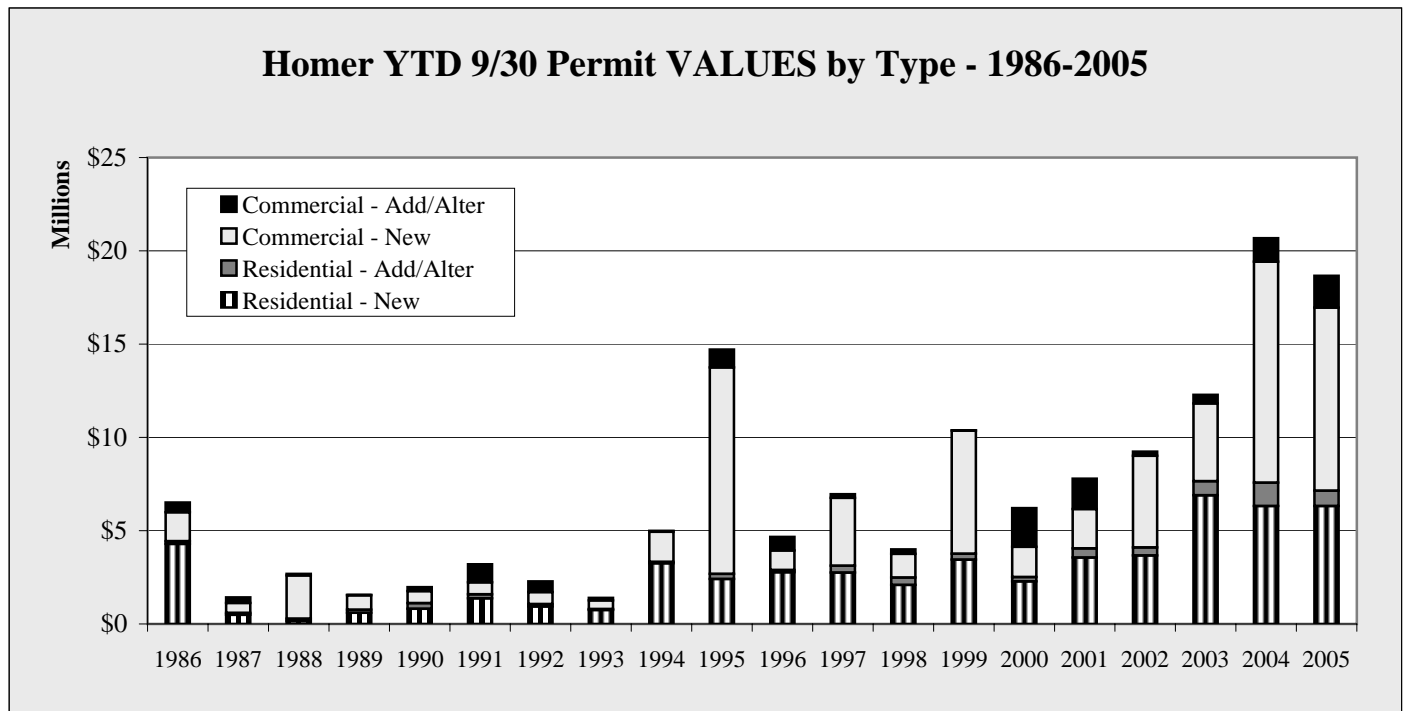

Chart 2.17

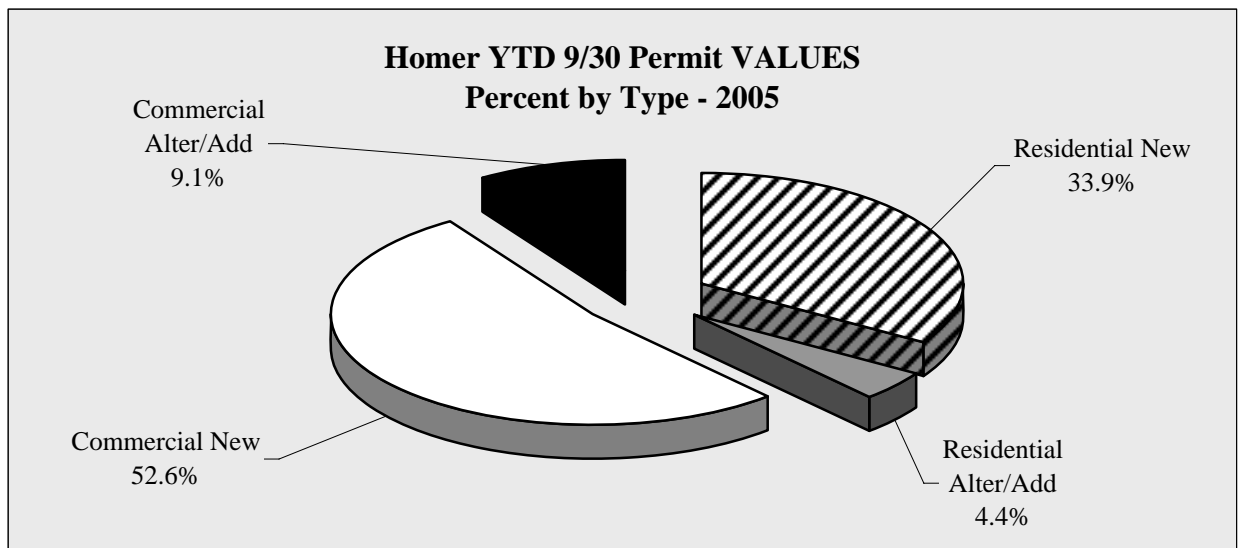

Chart 2.18

Homer Construction Permitting

Homer YTD 9/30 Permit VOLUME by Type - 1999-2005

	1999	2000	2001	2002	2003	2004	2005	Annual Change
Residential New	18	19	26	27	38	35	46	31.4%
Residential Alter/Add	15	8	17	14	17	28	22	-21.4%
Commercial New	11	6	7	7	10	15	14	-6.7%
Commercial Alter/Add	2	17	13	6	8	6	10	66.7%
Total	46	50	63	54	73	84	92	9.5%
Annual Change		8.7%	26.0%	-14.3%	35.2%	15.1%	9.5%	

Table 2.24

Homer YTD 9/30 Permit VOLUME by Type - 1986-2005

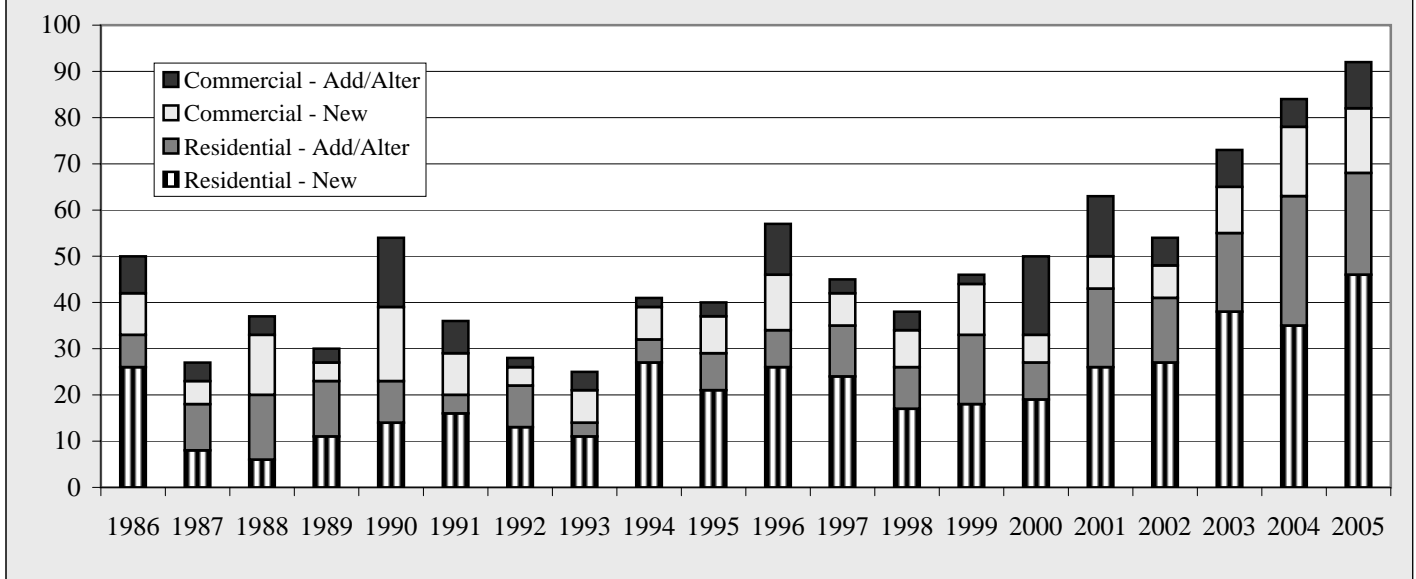

Chart 2.19

**Homer YTD 9/30 Permit VOLUME
Percent by Type - 2005**

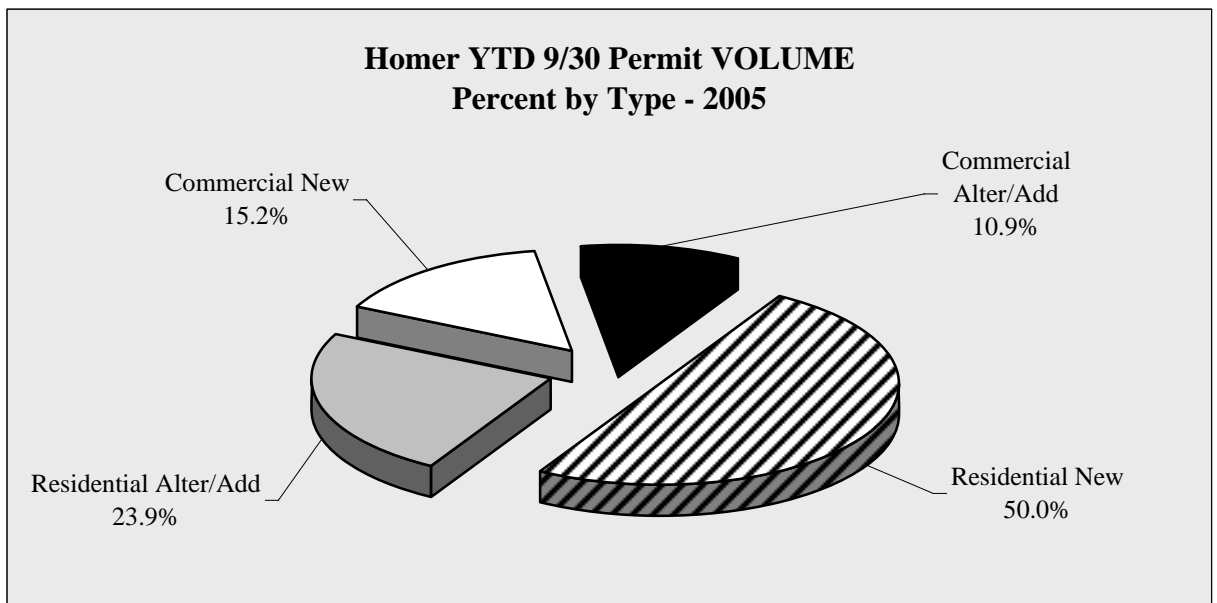

Chart 2.20

Homer Construction Permitting

Homer Annual Permit VALUES by Type - 1998-2004 - in \$								
	1998	1999	2000	2001	2002	2003	2004	Annual Change
Residential New	2,850,750	3,646,000	2,611,040	4,047,780	4,226,720	8,120,455	6,695,500	-17.5%
Residential Alter/Add	539,600	367,000	230,060	609,160	536,620	806,600	1,695,550	110.2%
Commercial New	2,528,025	6,906,000	1,663,480	2,410,800	4,990,740	5,764,520	14,400,518	149.8%
Commercial Alter/Add	281,500	21,000	2,624,392	12,732,950	294,699	635,240	1,279,063	101.4%
Total	6,199,875	10,940,000	7,128,972	19,800,690	10,048,779	15,326,815	24,070,631	57.0%
Annual Change		76.5%	-34.8%	177.7%	-49.3%	52.5%	57.0%	

Table 2.25

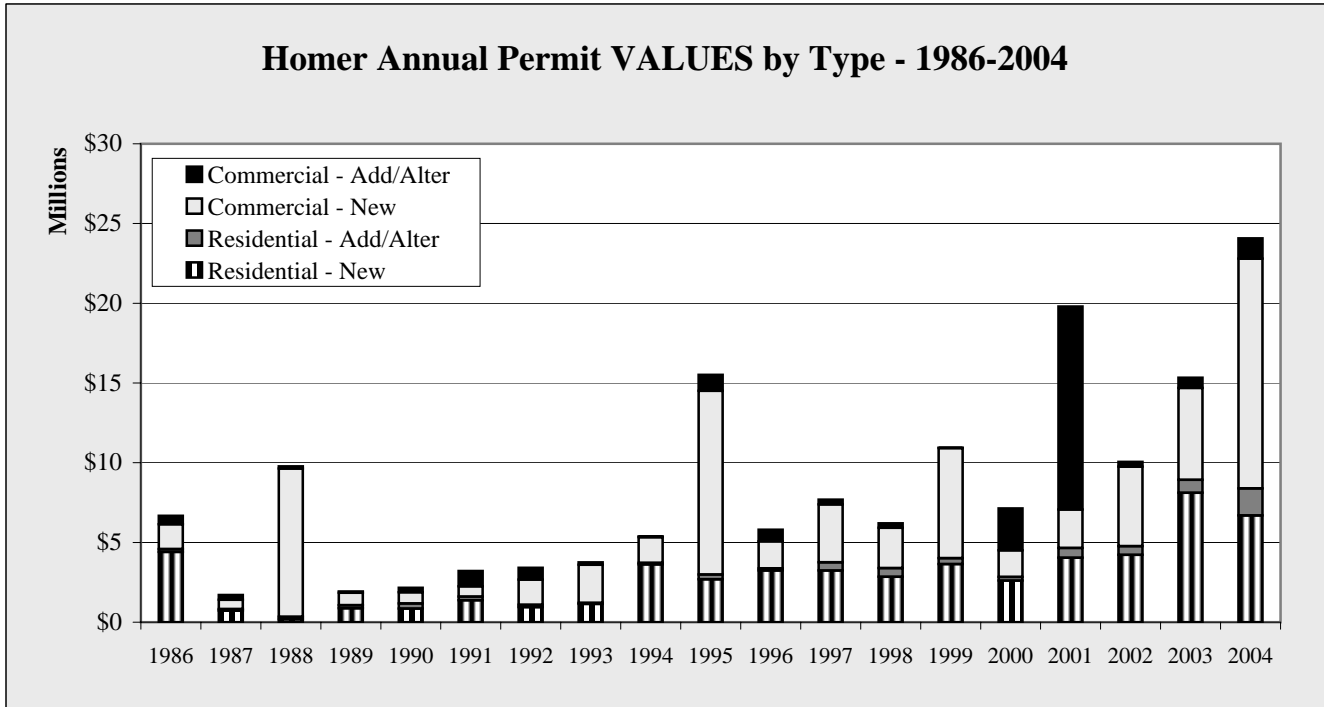

Chart 2.21

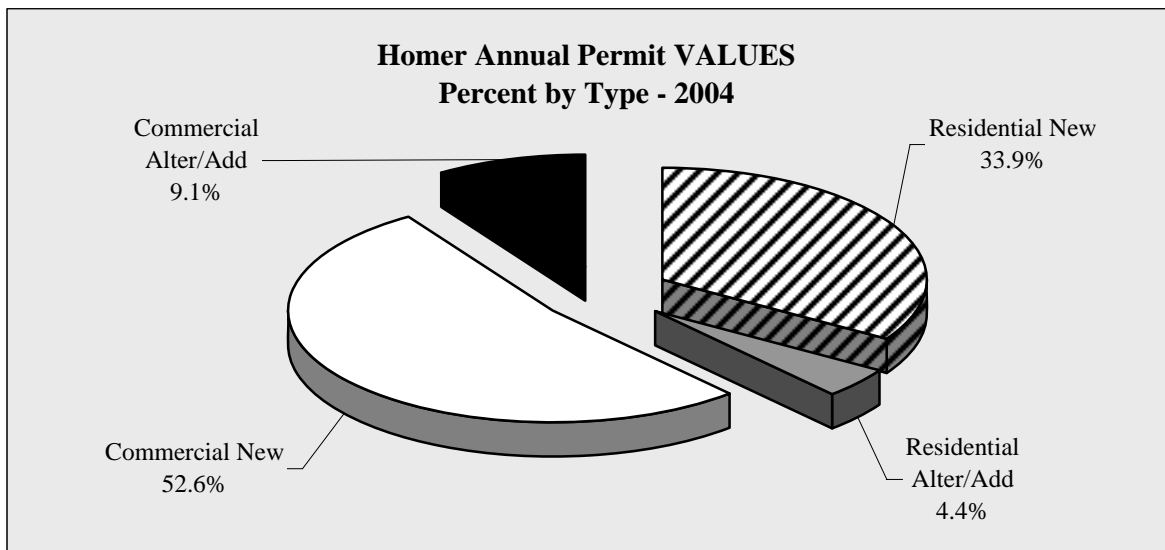

Chart 2.22

Homer Construction Permitting

Homer Annual Permit VALUES by Type - 1998-2004 - in \$

	1998	1999	2000	2001	2002	2003	2004	Annual Change
Residential New	23	21	23	30	32	47	41	-12.8%
Residential Alter/Add	11	17	8	19	20	19	37	94.7%
Commercial New	9	12	8	8	8	11	22	100.0%
Commercial Alter/Add	5	2	19	15	7	9	8	-11.1%
Total	48	52	58	72	67	86	108	25.6%
Annual Change		8.3%	11.5%	24.1%	-6.9%	28.4%	25.6%	

Table 2.26

Homer Annual Permit VOLUME by Type - 1986-2004

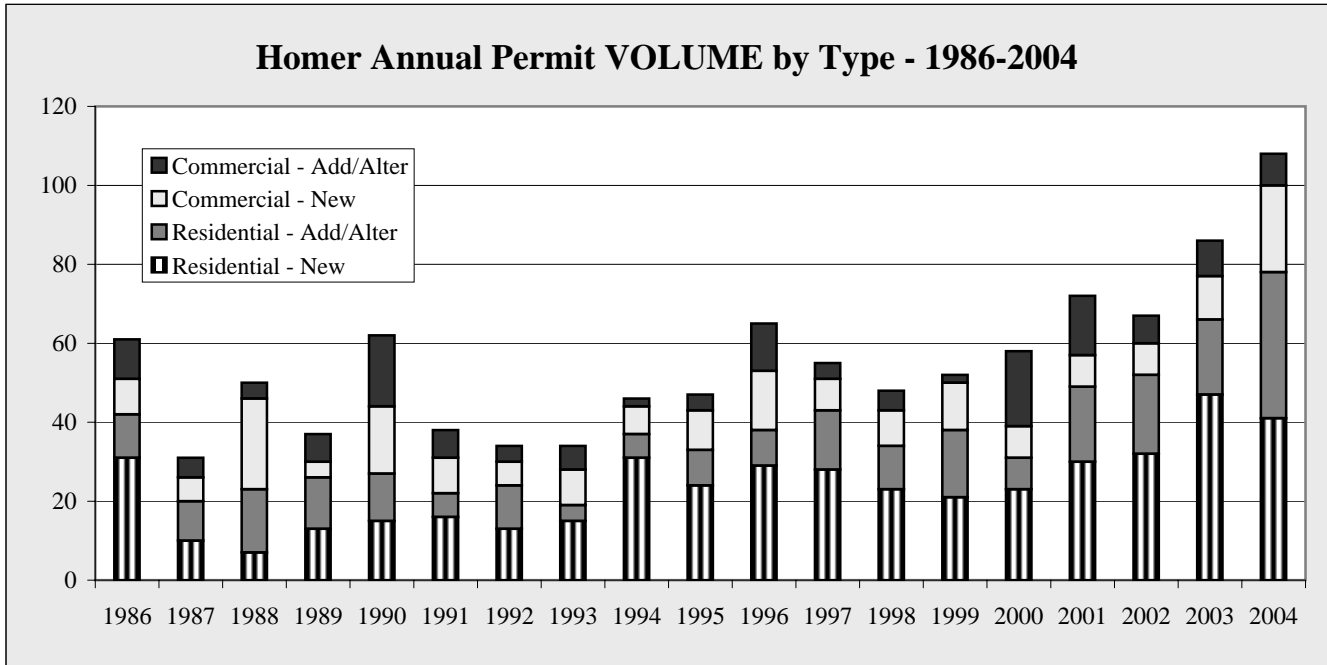

Chart 2.23

**Homer Annual Permit VOLUME
Percent by Type - 2004**

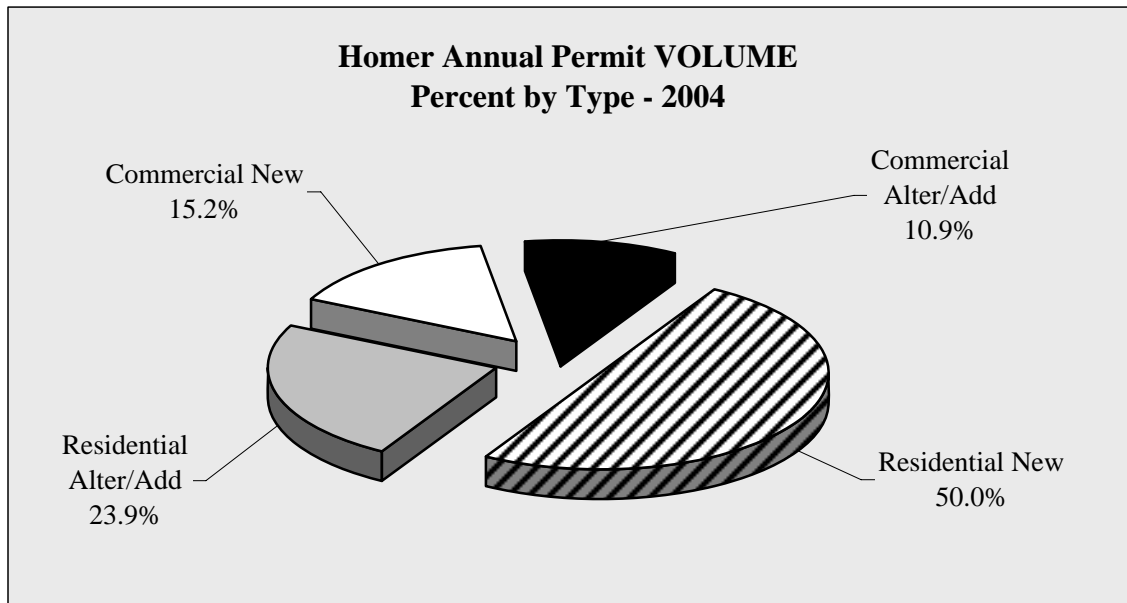

Chart 2.24

Homer Construction Permitting

Homer Annual Permit VALUES by Type by Quarter - 1998-2005 - in \$					
	1st Quarter	2nd Quarter	3rd Quarter	4th Quarter	Total
1998					
Residential - New	594,000	875,000	620,000	761,750	2,850,750
Residential - Add/Alter	0	140,400	254,200	145,000	539,600
Commercial - New	35,970	1,192,036	41,019	1,259,000	2,528,025
Commercial - Add/Alter	0	66,500	175,000	40,000	281,500
TOTAL	629,970	2,273,936	1,090,219	2,205,750	6,199,875
1999					
Residential - New	1,673,000	1,038,000	740,000	195,000	3,646,000
Residential - Add/Alter	0	118,000	199,000	50,000	367,000
Commercial - New	270,000	1,520,000	4,800,000	316,000	6,906,000
Commercial - Add/Alter	0	15,000	6,000	0	21,000
TOTAL	1,943,000	2,691,000	5,745,000	561,000	10,940,000
2000					
Residential - New	392,600	867,440	1,025,000	326,000	2,611,040
Residential - Add/Alter	5,500	115,000	109,560	0	230,060
Commercial - New	85,000	725,480	805,000	48,000	1,663,480
Commercial - Add/Alter	1,315,000	558,000	207,410	543,982	2,624,392
TOTAL	1,798,100	2,265,920	2,146,970	917,982	7,128,972
2001					
Residential - New	300,000	2,093,800	1,161,680	492,300	4,047,780
Residential - Add/Alter	60,000	306,440	122,720	120,000	609,160
Commercial - New	285,000	1,485,800	340,000	300,000	2,410,800
Commercial - Add/Alter	45,000	216,000	1,371,950	11,100,000	12,732,950
TOTAL	690,000	4,102,040	2,996,350	12,012,300	19,800,690
2002					
Residential - New	891,760	1,308,460	1,466,300	560,200	4,226,720
Residential - Add/Alter	8,960	205,400	217,940	104,320	536,620
Commercial - New	0	1,000,000	3,912,740	78,000	4,990,740
Commercial - Add/Alter	28,000	14,349	180,350	72,000	294,699
TOTAL	928,720	2,528,209	5,777,330	814,520	10,048,779
2003					
Residential - New	979,800	3,811,480	2,106,275	1,222,900	8,120,455
Residential - Add/Alter	232,540	239,060	285,000	50,000	806,600
Commercial - New	0	3,535,720	628,800	1,600,000	5,764,520
Commercial - Add/Alter	122,000	343,240	0	170,000	635,240
TOTAL	1,334,340	7,929,500	3,020,075	3,042,900	15,326,815
2004					
Residential - New	2,597,500	2,495,400	1,225,600	377,000	6,695,500
Residential - Add/Alter	201,520	205,730	851,300	437,000	1,695,550
Commercial - New	915,000	4,700,518	6,225,000	2,560,000	14,400,518
Commercial - Add/Alter	0	32,063	1,230,000	17,000	1,279,063
TOTAL	3,714,020	7,433,711	9,531,900	3,391,000	24,070,631
2005					
Residential - New	1,694,400	3,072,000	1,558,500		6,324,900
Residential - Add/Alter	1,500	451,000	364,000		816,500
Commercial - New	108,000	7,469,000	2,240,000		9,817,000
Commercial - Add/Alter	1,302,000	250,000	150,000		1,702,000
TOTAL	3,105,900	11,242,000	4,312,500		18,660,400
					Year to Date

Table 2.27

Homer Construction Permitting

Homer Annual Permit VOLUME by Type by Quarter - 1998-2005					
	1st Quarter	2nd Quarter	3rd Quarter	4th Quarter	Total
1998					
Residential - New	5	6	6	6	23
Residential - Add/Alter	0	4	5	2	11
Commercial - New	1	5	2	1	9
Commercial - Add/Alter	0	3	1	1	5
TOTAL	6	18	14	10	48
1999					
Residential - New	3	9	6	3	21
Residential - Add/Alter	0	4	11	2	17
Commercial - New	2	7	2	1	12
Commercial - Add/Alter	0	1	1	0	2
TOTAL	5	21	20	6	52
2000					
Residential - New	4	7	8	4	23
Residential - Add/Alter	1	2	5	0	8
Commercial - New	1	3	2	2	8
Commercial - Add/Alter	3	8	6	2	19
TOTAL	9	20	21	8	58
2001					
Residential - New	3	14	9	4	30
Residential - Add/Alter	1	12	4	2	19
Commercial - New	2	3	2	1	8
Commercial - Add/Alter	1	5	7	2	15
TOTAL	7	34	22	9	72
2002					
Residential - New	8	9	10	5	32
Residential - Add/Alter	1	5	8	6	20
Commercial - New	0	1	6	1	8
Commercial - Add/Alter	1	2	3	1	7
TOTAL	10	17	27	13	67
2003					
Residential - New	6	17	15	9	47
Residential - Add/Alter	8	6	3	2	19
Commercial - New	0	7	3	1	11
Commercial - Add/Alter	4	4	0	1	9
TOTAL	18	34	21	13	86
2004					
Residential - New	11	15	9	6	41
Residential - Add/Alter	2	5	21	9	37
Commercial - New	2	5	8	7	22
Commercial - Add/Alter	1	1	4	2	8
TOTAL	16	26	42	24	108
2005					Year to Date
Residential - New	10	22	14		46
Residential - Add/Alter	1	13	8		22
Commercial - New	2	10	2		14
Commercial - Add/Alter	5	2	3		10
TOTAL	18	47	27		92

Table 2.28

Homer Cost of Food

Cost of food data is collected by the University of Alaska, Fairbanks Cooperative Extension. Each quarter the Cooperative Extension surveys up to three grocers in communities throughout the state to determine the cost of food for one week. Specific guidelines are presented to the surveyors regarding item size and sale price for 104 items.

HOMER							
	September 2000	September 2001	September 2002	September 2003	September 2004	September 2005	Annual Change
Sales Tax (in percent)	5.5	5.5	5.5	5.5	5.5	6.5	
Percent of Food Unavailable	0.0	1.0	0.0	0.0	0.0	0.0	
Child 1 year	19.9	20.5	20.6	20.3	20.9	22.4	7.1%
Child 2 years	0.0	20.5	20.6	20.3	20.7	22.1	7.0%
Children 3-5 years	21.9	22.6	22.6	22.1	22.9	24.4	6.7%
Children 6-8 years	29.1	30.0	30.2	29.6	30.6	32.8	7.5%
Children 9-11 years	33.0	34.0	34.2	33.4	34.5	37.1	7.4%
Males 12-14 years	37.4	38.5	38.7	37.7	39.0	41.9	7.3%
Males 15-19 years	38.5	39.7	39.9	38.9	40.1	43.1	7.7%
Males 20-50 years	38.3	39.5	39.8	38.8	40.2	43.1	7.3%
Males 51 years & over	36.4	37.5	37.9	37.0	38.2	40.9	7.1%
Females 12-19 years	32.1	33.2	33.2	32.6	33.6	36.1	7.4%
Females 20-50 years	33.5	34.4	34.7	33.8	34.9	37.5	7.3%
Females 51 years and over	32.5	33.5	33.7	32.8	34.0	36.4	7.1%
Family of 2 (20-50 years)	78.9	81.3	81.9	79.9	82.6	88.6	7.3%
Family of 2 (51 & older)	75.8	78.1	78.7	76.8	79.4	85.1	7.2%
Family of 4 children 1-5 years	113.5	117.1	117.6	114.8	118.7	127.1	7.1%
Family of 4 children 6-11 years	133.8	138.0	138.9	135.6	140.2	150.5	7.4%
Electricity, 1000 kWh	114.3	122.6	126.8	114.3	121.9	137.0	12.4%
Heating oil, 55 gal	89.1	75.4	67.1	82.5	98.5	149.6	52.0%
Gas-55 gal unleaded auto	99.5	96.8	93.8	108.3	121.5	159.5	31.2%
Lumber, 2X4X8'	2.8	3.2	3.0	3.1	3.8	3.2	-17.5%
Propane, 100 LB refill	36.4	40.0	38.7	44.9	50.5	59.9	18.8%

Table 2.29

Homer Cost of Food

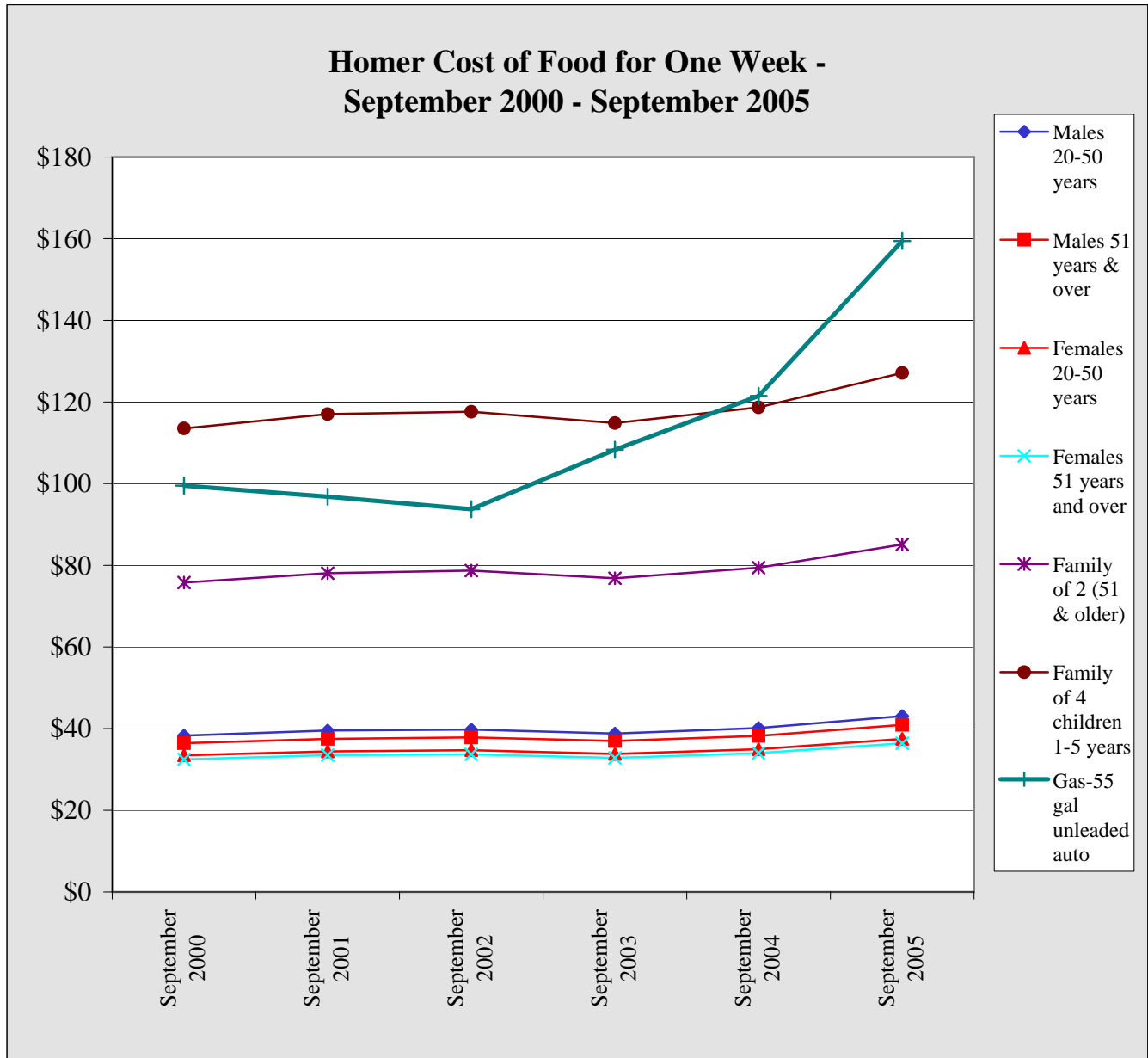

Chart 2.25

Kenai Sales

Kenai 3rd Quarter GROSS Sales by Industry by Quarter - 1999-2005 - in \$								
	1999	2000	2001	2002	2003	2004	2005	Annual Change
AFF	23,922,889	13,179,133	9,057,642	7,279,641	10,272,676	12,241,519	14,137,207	15.5%
Min	411,595	1,302,321	812,418	805,341	1,517,115	2,186,041	3,231,706	47.8%
Const	6,518,785	6,193,969	10,088,639	4,991,407	7,848,712	3,619,374	8,600,545	137.6%
Manu	2,379,731	2,879,442	3,375,577	3,464,827	5,529,544	2,757,875	8,177,381	196.5%
TCPU	5,969,048	5,674,917	5,821,003	8,070,497	4,859,475	11,816,038	8,825,948	-25.3%
Whole	3,209,594	5,701,717	5,500,470	5,410,024	5,639,800	7,155,295	7,171,027	0.2%
Retail	36,653,136	41,433,401	45,444,009	36,679,657	30,099,399	40,496,449	42,831,723	5.8%
FIRE	2,501,470	3,148,300	3,566,974	3,373,799	3,155,128	3,445,709	3,554,671	3.2%
Service	10,314,360	9,992,366	11,243,556	12,526,446	12,318,427	14,140,495	14,763,810	4.4%
Govt	120	0	1,213	0	0	0	0	NA
Total	91,880,728	89,505,566	94,911,501	82,601,639	81,240,276	97,858,795	111,294,018	13.7%
Annual Change		-2.6%	6.0%	-13.0%	-1.6%	20.5%	13.7%	

Table 3.1

Kenai 3rd Quarter GROSS Sales Ten Year Change by INDUSTRY - 1995 v. 2005 - in \$				
			10 Year Change	
	1995	2005	Percentage	Numerical
AFF	45,019,454	14,137,207	-68.6%	-30,882,247
Min	1,277,522	3,231,706	153.0%	1,954,184
Const	9,653,033	8,600,545	-10.9%	-1,052,488
Manu	1,639,070	8,177,381	398.9%	6,538,311
TCPU	3,959,617	8,825,948	122.9%	4,866,331
Whole	3,498,669	7,171,027	105.0%	3,672,358
Retail	26,841,963	42,831,723	59.6%	15,989,760
FIRE	2,827,419	3,554,671	25.7%	727,252
Service	9,181,967	14,763,810	60.8%	5,581,843
Govt	8	0	-100.0%	-8
Total	103,898,722	111,294,018	7.1%	7,395,296

Table 3.2

Kenai 3rd Quarter GROSS Sales One Year Change by INDUSTRY - 2004 v. 2005 - in \$				
			1 Year Change	
	2004	2005	Percentage	Numerical
AFF	12,241,519	14,137,207	15.5%	1,895,688
Min	2,186,041	3,231,706	47.8%	1,045,665
Const	3,619,374	8,600,545	137.6%	4,981,171
Manu	2,757,875	8,177,381	196.5%	5,419,506
TCPU	11,816,038	8,825,948	-25.3%	-2,990,090
Whole	7,155,295	7,171,027	0.2%	15,732
Retail	40,496,449	42,831,723	5.8%	2,335,274
FIRE	3,445,709	3,554,671	3.2%	108,962
Service	14,140,495	14,763,810	4.4%	623,315
Govt	0	0	0.0%	0
Total	97,858,795	111,294,018	13.7%	13,435,223

Table 3.3

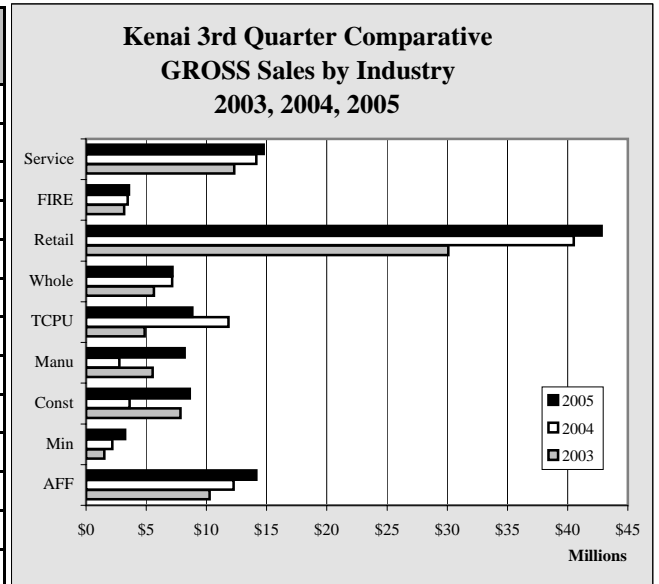

Chart 3.1

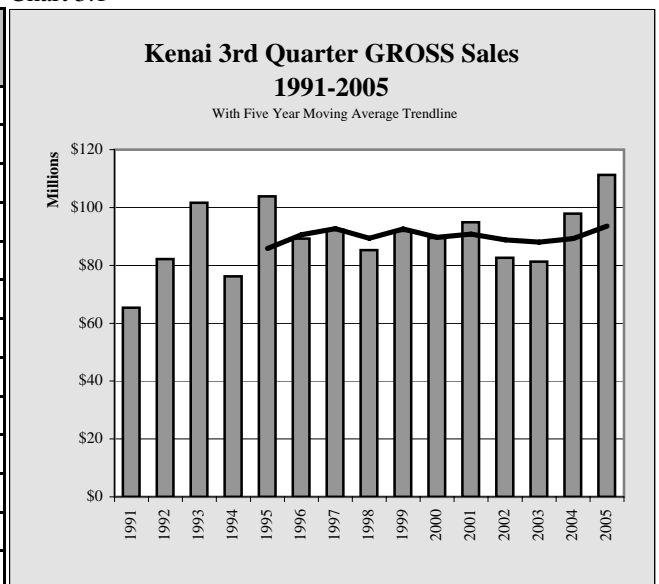

Chart 3.2

Kenai Sales

Kenai 3rd Quarter TAXABLE Sales by Industry by Quarter - 1999-2005 - in \$								
	1999	2000	2001	2002	2003	2004	2005	Annual Change
AFF	217,204	222,890	204,015	200,238	237,344	351,638	425,830	21.1%
Min	42,013	57,756	49,930	52,898	51,411	75,540	52,988	-29.9%
Const	323,353	304,909	311,229	292,612	312,562	307,561	239,169	-22.2%
Manu	710,517	783,705	701,303	754,966	816,883	1,023,087	1,097,570	7.3%
TCPU	3,145,749	3,111,407	3,173,560	4,235,801	3,270,630	3,197,445	3,378,215	5.7%
Whole	237,318	267,007	187,990	138,933	145,387	109,725	123,876	12.9%
Retail	22,965,735	24,494,096	25,846,738	24,650,115	19,174,865	26,970,841	29,088,247	7.9%
FIRE	1,208,457	1,552,654	1,791,530	1,706,454	1,387,466	1,373,838	1,308,936	-4.7%
Service	5,709,728	5,839,939	5,895,307	6,160,963	5,965,690	6,631,650	6,925,412	4.4%
Govt	120	0	1,213	0	0	0	0	NA
Total	34,560,194	36,634,363	38,162,815	38,192,980	31,362,238	40,041,325	42,640,243	6.5%
Annual Change		6.0%	4.2%	0.1%	-17.9%	27.7%	6.5%	

Table 3.4

Kenai 3rd Quarter TAXABLE Sales Ten Year Change by INDUSTRY - 1995 v. 2005 - in \$				
			10 Year Change	
	1995	2005	Percentage	Numerical
AFF	349,803	425,830	21.7%	76,027
Min	77,937	52,988	-32.0%	-24,949
Const	301,025	239,169	-20.5%	-61,856
Manu	754,882	1,097,570	45.4%	342,688
TCPU	2,577,881	3,378,215	31.0%	800,334
Whole	316,267	123,876	-60.8%	-192,391
Retail	21,297,829	29,088,247	36.6%	7,790,418
FIRE	1,330,409	1,308,936	-1.6%	-21,473
Service	5,449,024	6,925,412	27.1%	1,476,388
Govt	8	0	-100.0%	-8
Total	32,455,065	42,640,243	31.4%	10,185,178

Table 3.5

Kenai 3rd Quarter TAXABLE Sales One Year Change by INDUSTRY - 2004 v. 2005 - in \$				
			1 Year Change	
	2004	2005	Percentage	Numerical
AFF	351,638	425,830	21.1%	74,192
Min	75,540	52,988	-29.9%	-22,552
Const	307,561	239,169	-22.2%	-68,392
Manu	1,023,087	1,097,570	7.3%	74,483
TCPU	3,197,445	3,378,215	5.7%	180,770
Whole	109,725	123,876	12.9%	14,151
Retail	26,970,841	29,088,247	7.9%	2,117,406
FIRE	1,373,838	1,308,936	-4.7%	-64,902
Service	6,631,650	6,925,412	4.4%	293,762
Govt	0	0	0.0%	0
Total	40,041,325	42,640,243	6.5%	2,598,918

Table 3.6

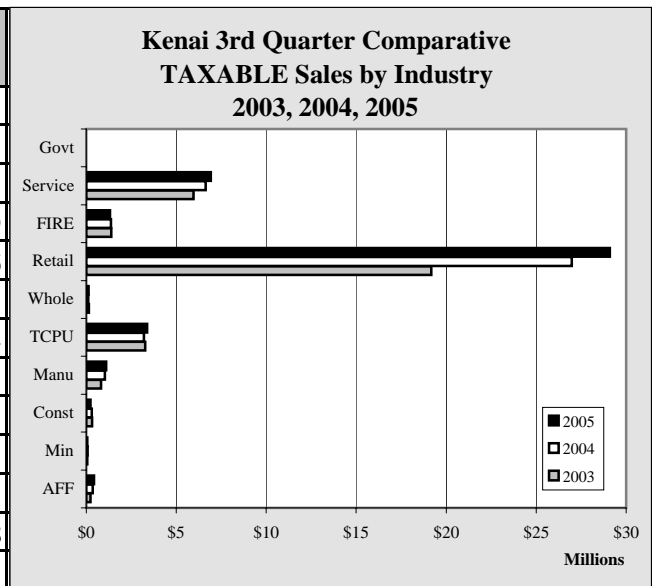

Chart 3.3

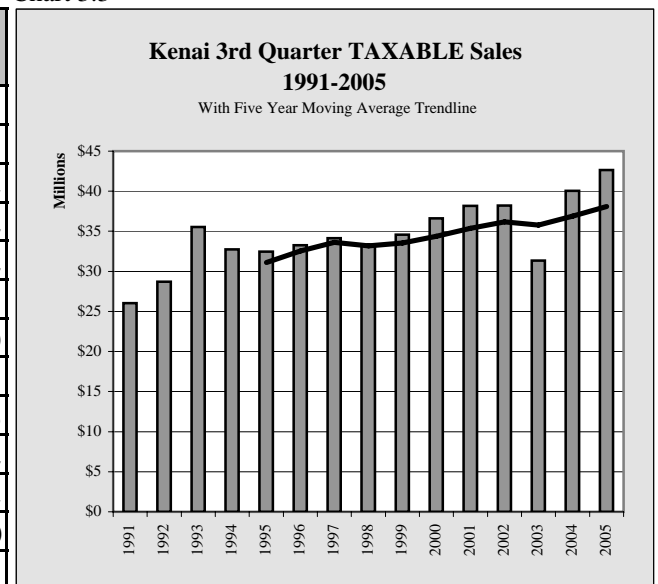

Chart 3.4

Kenai Sales

Kenai YTD 9/30 GROSS Sales by Industry by Quarter - 1999-2005 - in \$								
	1999	2000	2001	2002	2003	2004	2005	Annual Change
AFF	25,822,535	17,610,231	10,478,583	9,260,820	12,114,060	14,600,190	18,111,750	24.1%
Min	513,485	4,149,598	1,986,662	3,536,466	3,332,473	6,370,132	6,543,412	2.7%
Const	13,028,856	12,395,146	17,293,874	13,063,811	18,336,100	8,595,516	16,918,070	96.8%
Manu	5,801,011	7,638,667	9,751,988	8,728,167	12,736,843	7,430,745	12,283,127	65.3%
TCPU	18,374,488	17,875,604	17,734,860	20,642,088	18,725,902	29,967,153	57,382,999	91.5%
Whole	7,746,072	12,795,674	15,731,816	13,452,007	13,703,279	18,347,434	18,735,768	2.1%
Retail	98,766,272	104,564,622	122,426,743	99,895,010	89,156,625	109,562,616	113,636,216	3.7%
FIRE	7,877,299	8,579,709	10,043,017	10,480,569	9,565,847	9,658,568	9,462,749	-2.0%
Service	24,865,428	25,664,198	28,554,967	32,068,361	33,154,803	34,796,807	35,200,388	1.2%
Govt	343	256	1,213	0	0	0	0	NA
Total	202,795,789	211,273,705	234,003,723	211,127,299	210,825,932	239,329,161	288,274,479	20.5%
Annual Change		4.2%	10.8%	-9.8%	-0.1%	13.5%	20.5%	

Table 3.7

Kenai YTD 9/30 GROSS Sales Ten Year Change by INDUSTRY - 1995 v. 2005 - in \$				
			10 Year Change	
	1995	2005	Percentage	Numerical
AFF	71,004,145	18,111,750	-74.5%	-52,892,395
Min	4,116,347	6,543,412	59.0%	2,427,065
Const	14,087,417	16,918,070	20.1%	2,830,653
Manu	4,183,601	12,283,127	193.6%	8,099,526
TCPU	11,751,696	57,382,999	388.3%	45,631,303
Whole	8,667,225	18,735,768	116.2%	10,068,543
Retail	68,563,489	113,636,216	65.7%	45,072,727
FIRE	7,872,315	9,462,749	20.2%	1,590,434
Service	23,876,459	35,200,388	47.4%	11,323,929
Govt	1,051	0	-100.0%	-1,051
Total	214,123,745	288,274,479	34.6%	74,150,734

Table 3.8

Kenai YTD 9/30 GROSS Sales One Year Change by INDUSTRY - 2004 v. 2005 - in \$				
			1 Year Change	
	2004	2005	Percentage	Numerical
AFF	14,600,190	18,111,750	24.1%	3,511,560
Min	6,370,132	6,543,412	2.7%	173,280
Const	8,595,516	16,918,070	96.8%	8,322,554
Manu	7,430,745	12,283,127	65.3%	4,852,382
TCPU	29,967,153	57,382,999	91.5%	27,415,846
Whole	18,347,434	18,735,768	2.1%	388,334
Retail	109,562,616	113,636,216	3.7%	4,073,600
FIRE	9,658,568	9,462,749	-2.0%	-195,819
Service	34,796,807	35,200,388	1.2%	403,581
Govt	0	0	0.0%	0
Total	239,329,161	288,274,479	20.5%	48,945,318

Table 3.9

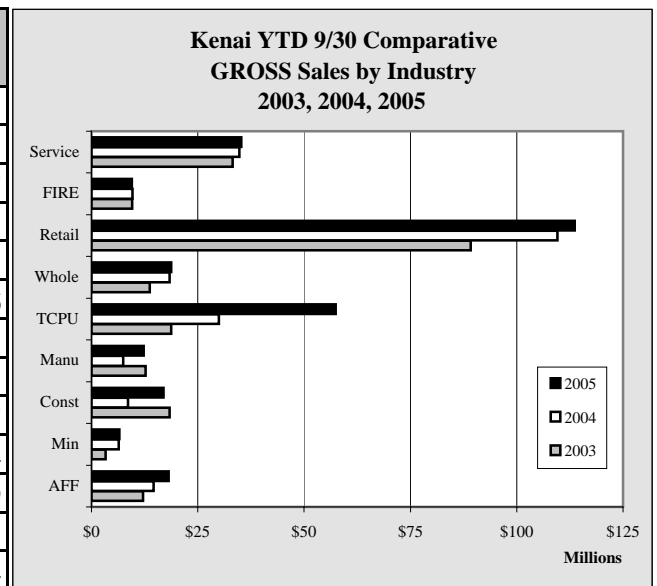

Chart 3.5

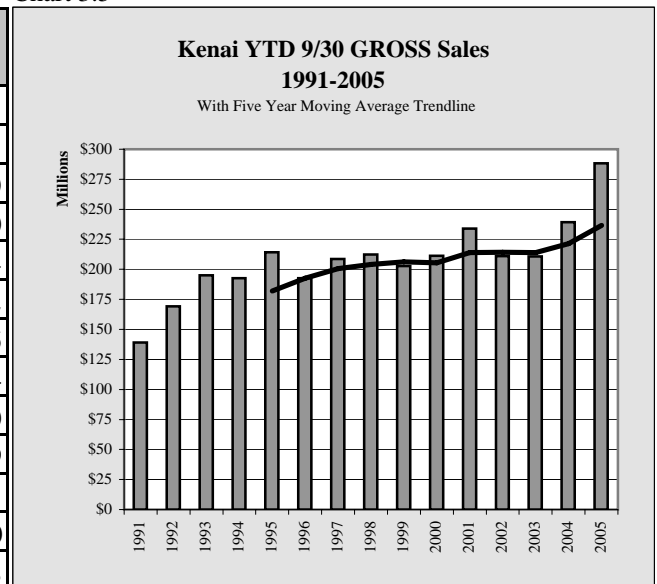

Chart 3.6

Kenai Sales

Kenai YTD 9/30 TAXABLE Sales by Industry by Quarter - 1999-2005 - in \$								
	1999	2000	2001	2002	2003	2004	2005	Annual Change
AFF	421,773	429,603	405,346	419,403	460,021	608,276	754,415	24.0%
Min	55,961	120,841	181,310	161,747	132,253	196,942	169,602	-13.9%
Const	857,434	798,302	817,098	814,586	843,584	862,044	747,654	-13.3%
Manu	1,642,697	1,898,006	1,824,085	1,727,201	1,945,510	2,335,759	2,266,654	-3.0%
TCPU	9,953,537	10,220,979	9,735,719	11,810,523	12,258,712	10,604,783	10,596,316	-0.1%
Whole	612,131	695,503	574,280	393,709	336,789	389,644	340,015	-12.7%
Retail	59,532,622	61,396,610	67,701,293	66,212,178	57,483,719	71,433,211	75,065,417	5.1%
FIRE	3,677,428	4,102,400	4,989,242	5,036,081	4,391,093	4,007,103	3,793,447	-5.3%
Service	13,895,350	14,041,281	14,811,139	15,205,459	14,426,587	15,423,212	15,821,656	2.6%
Govt	343	256	1,213	0	0	0	0	NA
Total	90,649,276	93,703,781	101,040,725	101,780,887	92,278,268	105,860,974	109,555,176	3.5%
Annual Change		3.4%	7.8%	0.7%	-9.3%	14.7%	3.5%	

Table 3.10

Kenai YTD 9/30 TAXABLE Sales Ten Year Change by INDUSTRY - 1995 v. 2005 - in \$				
			10 Year Change	
	1995	2005	Percentage	Numerical
AFF	597,086	754,415	26.3%	157,329
Min	119,415	169,602	42.0%	50,187
Const	793,859	747,654	-5.8%	-46,205
Manu	1,534,219	2,266,654	47.7%	732,435
TCPU	8,174,086	10,596,316	29.6%	2,422,230
Whole	799,304	340,015	-57.5%	-459,289
Retail	54,091,775	75,065,417	38.8%	20,973,642
FIRE	3,882,241	3,793,447	-2.3%	-88,794
Service	13,607,460	15,821,656	16.3%	2,214,196
Govt	1,051	0	-100.0%	-1,051
Total	83,600,496	109,555,176	31.0%	25,954,680

Table 3.11

Kenai YTD 9/30 TAXABLE Sales One Year Change by INDUSTRY - 2004 v. 2005 - in \$				
			1 Year Change	
	2004	2005	Percentage	Numerical
AFF	608,276	754,415	24.0%	146,139
Min	196,942	169,602	-13.9%	-27,340
Const	862,044	747,654	-13.3%	-114,390
Manu	2,335,759	2,266,654	-3.0%	-69,105
TCPU	10,604,783	10,596,316	-0.1%	-8,467
Whole	389,644	340,015	-12.7%	-49,629
Retail	71,433,211	75,065,417	5.1%	3,632,206
FIRE	4,007,103	3,793,447	-5.3%	-213,656
Service	15,423,212	15,821,656	2.6%	398,444
Govt	0	0	0.0%	0
Total	105,860,974	109,555,176	3.5%	3,694,202

Table 3.12

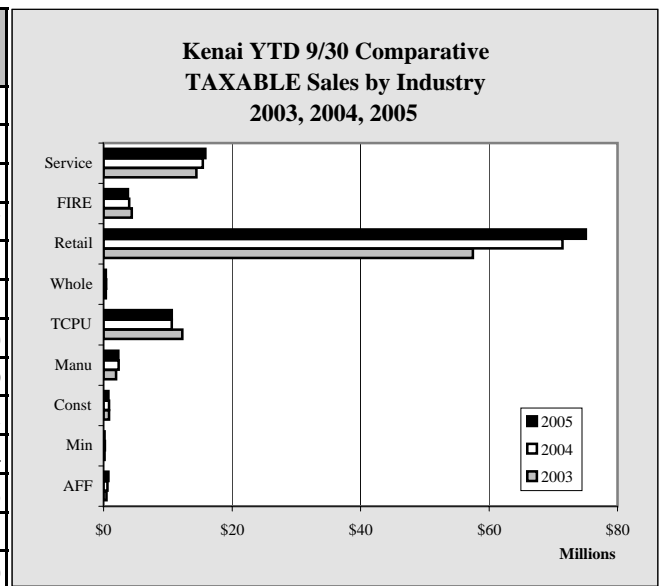

Chart 3.7

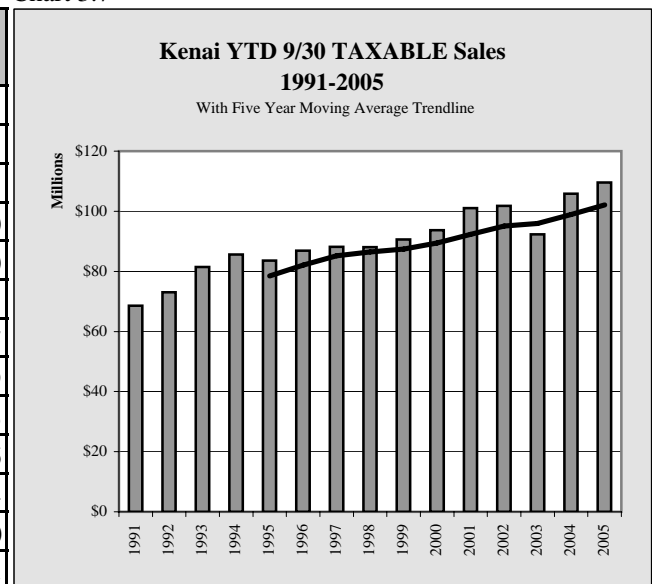

Chart 3.8

Kenai Sales

Kenai Annual GROSS Sales by Industry by Quarter - 1998-2004 - in \$								
	1998	1999	2000	2001	2002	2003	2004	Annual Change
AFF	21,856,770	27,031,481	17,757,626	11,304,090	9,488,174	12,584,181	16,349,894	29.9%
Min	208,531	1,424,691	5,507,130	2,507,234	3,916,074	4,915,930	8,727,840	77.5%
Const	21,481,466	20,692,714	17,177,398	24,151,985	18,522,782	30,522,706	12,776,832	-58.1%
Manu	7,526,545	7,854,159	10,445,806	12,646,047	12,496,147	14,994,862	9,506,441	-36.6%
TCPU	23,017,785	26,815,943	23,883,929	24,107,421	27,762,814	24,667,417	35,991,564	45.9%
Whole	10,194,981	10,520,958	17,902,155	19,965,613	17,521,629	19,037,117	187,702,003	886.0%
Retail	149,397,570	133,272,201	145,306,370	164,046,542	134,565,667	119,219,213	146,046,383	22.5%
FIRE	10,300,066	10,463,600	11,935,000	13,853,920	13,529,801	12,940,552	13,095,553	1.2%
Service	36,094,281	32,669,956	33,766,762	37,842,360	41,942,315	44,532,684	45,266,750	1.6%
Govt	1,945	415	288	1,213	0	0	0	NA
Total	280,079,940	270,746,118	283,682,464	310,426,425	279,745,403	283,414,662	475,463,260	67.8%
Annual Change		-3.3%	4.8%	9.4%	-9.9%	1.3%	67.8%	

Table 3.13

Kenai Annual GROSS Sales Ten Year Change by INDUSTRY - 1994 v. 2004 - in \$				
			10 Year Change	
	1994	2004	Percentage	Numerical
AFF	46,004,369	16,349,894	-64.5%	-29,654,475
Min	6,226,069	8,727,840	40.2%	2,501,771
Const	17,078,902	12,776,832	-25.2%	-4,302,070
Manu	6,680,185	9,506,441	42.3%	2,826,256
TCPU	15,808,825	35,991,564	127.7%	20,182,739
Whole	11,538,916	187,702,003	1526.7%	176,163,087
Retail	94,924,239	146,046,383	53.9%	51,122,144
FIRE	19,103,386	13,095,553	-31.4%	-6,007,833
Service	31,849,248	45,266,750	42.1%	13,417,502
Govt	2,451	0	-100.0%	-2,451
Total	249,216,590	475,463,260	90.8%	226,246,670

Table 3.14

Kenai Annual GROSS Sales One Year Change by INDUSTRY - 2003 v. 2004 - in \$				
			1 Year Change	
	2003	2004	Percentage	Numerical
AFF	12,584,181	16,349,894	29.9%	3,765,713
Min	4,915,930	8,727,840	77.5%	3,811,910
Const	30,522,706	12,776,832	-58.1%	-17,745,874
Manu	14,994,862	9,506,441	-36.6%	-5,488,421
TCPU	24,667,417	35,991,564	45.9%	11,324,147
Whole	19,037,117	187,702,003	886.0%	168,664,886
Retail	119,219,213	146,046,383	22.5%	26,827,170
FIRE	12,940,552	13,095,553	1.2%	155,001
Service	44,532,684	45,266,750	1.6%	734,066
Govt	0	0	0.0%	0
Total	283,414,662	475,463,260	67.8%	192,048,598

Table 3.15

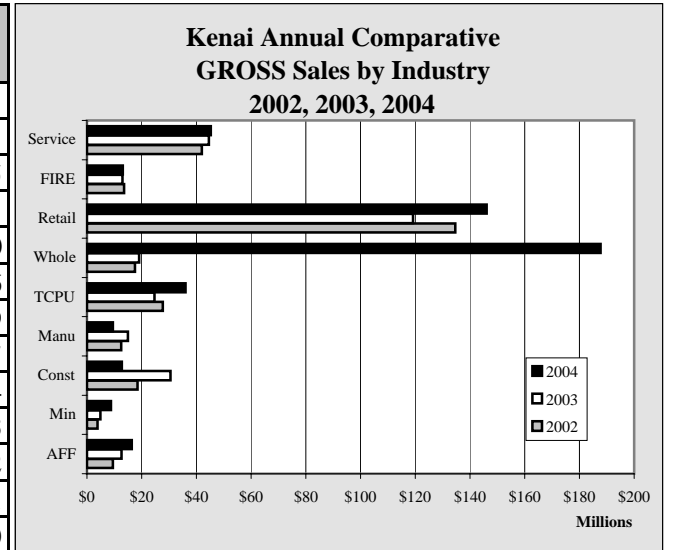

Chart 3.9

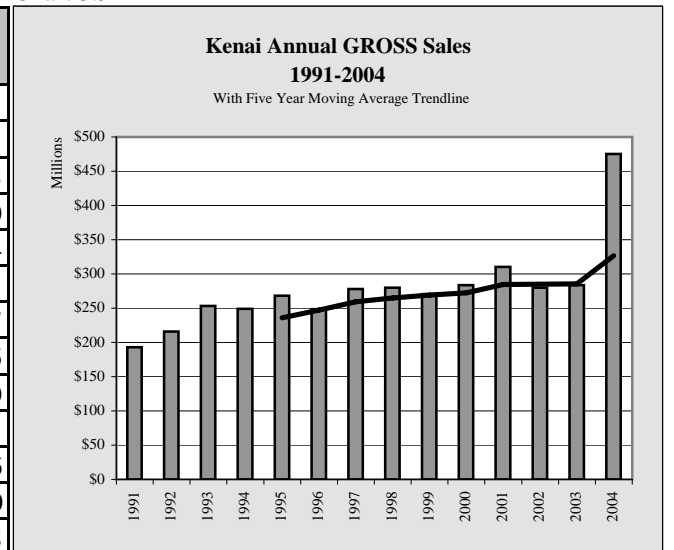

Chart 3.10

Kenai Sales

Kenai Annual TAXABLE Sales by Industry by Quarter - 1998-2004 - in \$								
	1998	1999	2000	2001	2002	2003	2004	Annual Change
AFF	448,689	513,026	518,603	505,615	505,614	559,313	718,415	28.4%
Min	49,522	96,651	166,846	223,196	213,971	192,718	262,963	36.4%
Const	1,200,303	1,180,607	1,085,964	1,171,924	1,111,101	1,152,569	1,124,337	-2.4%
Manu	2,140,912	2,085,657	2,450,721	2,238,645	2,218,515	2,451,929	2,853,082	16.4%
TCPU	12,899,378	15,330,911	13,458,834	13,192,948	16,120,066	15,890,944	14,094,256	-11.3%
Whole	877,088	829,682	898,759	727,784	517,025	494,254	473,716	-4.2%
Retail	80,814,442	81,828,974	85,347,467	93,226,651	90,195,938	76,153,080	94,195,956	23.7%
FIRE	4,918,254	4,824,067	5,718,387	6,757,340	6,600,246	5,663,081	5,279,184	-6.8%
Service	16,680,181	17,677,101	18,120,257	18,998,608	19,287,134	18,796,831	19,671,070	4.7%
Govt	1,938	415	288	1,213	0	0	0	NA
Total	120,030,707	124,367,091	127,766,126	137,043,924	136,769,610	121,354,719	138,672,979	14.3%
Annual Change		3.6%	2.7%	7.3%	-0.2%	-11.3%	14.3%	

Table 3.16

Kenai Annual TAXABLE Sales Ten Year Change by INDUSTRY - 1994 v. 2004 - in \$				
			10 Year Change	
	1994	2004	Percentage	Numerical
AFF	772,716	718,415	-7.0%	-54,301
Min	39,289	262,963	569.3%	223,674
Const	1,144,014	1,124,337	-1.7%	-19,677
Manu	2,021,420	2,853,082	41.1%	831,662
TCPU	10,714,369	14,094,256	31.5%	3,379,887
Whole	1,411,415	473,716	-66.4%	-937,699
Retail	76,411,101	94,195,956	23.3%	17,784,855
FIRE	5,079,409	5,279,184	3.9%	199,775
Service	16,805,851	19,671,070	17.0%	2,865,219
Govt	2,451	0	-100.0%	-2,451
Total	114,402,035	138,672,979	21.2%	24,270,944

Table 3.17

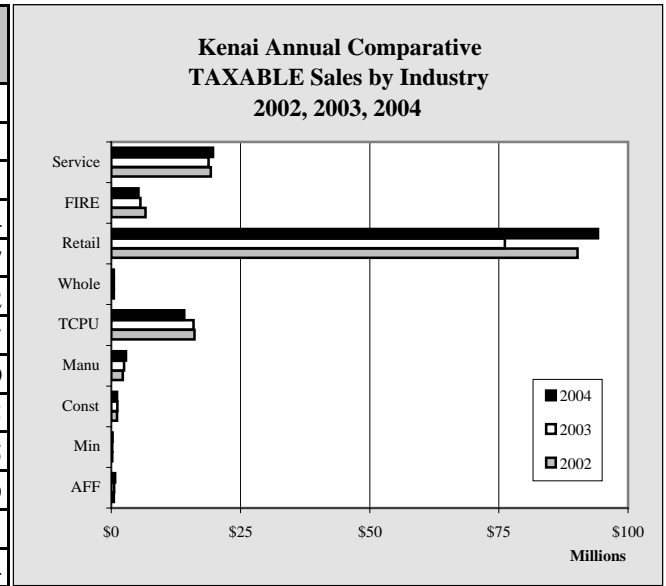

Chart 3.11

Kenai Annual TAXABLE Sales One Year Change by INDUSTRY - 2003 v. 2004 - in \$				
			1 Year Change	
	2003	2004	Percentage	Numerical
AFF	559,313	718,415	28.4%	159,102
Min	192,718	262,963	36.4%	70,245
Const	1,152,569	1,124,337	-2.4%	-28,232
Manu	2,451,929	2,853,082	16.4%	401,153
TCPU	15,890,944	14,094,256	-11.3%	-1,796,688
Whole	494,254	473,716	-4.2%	-20,538
Retail	76,153,080	94,195,956	23.7%	18,042,876
FIRE	5,663,081	5,279,184	-6.8%	-383,897
Service	18,796,831	19,671,070	4.7%	874,239
Govt	0	0	0.0%	0
Total	121,354,719	138,672,979	14.3%	17,318,260

Table 3.18

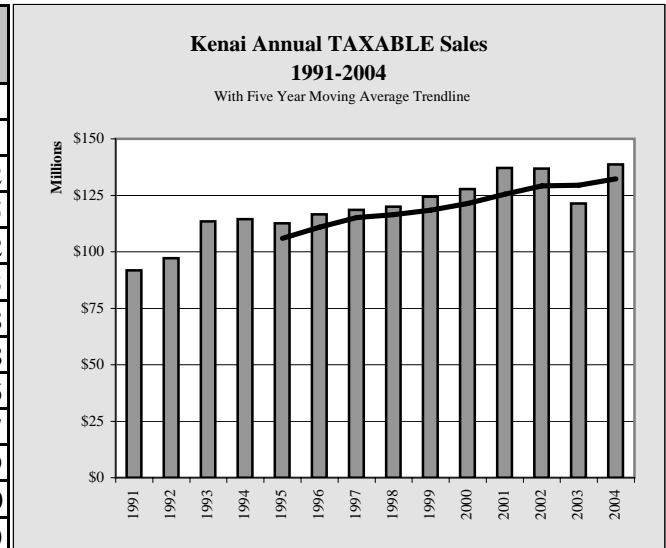

Chart 3.12

Kenai Sales

Kenai GROSS Sales by Industry by Quarter - 2002-2005 - in \$					
	1st Quarter	2nd Quarter	3rd Quarter	4th Quarter	Total
2002					
AFF	1,170,314	810,865	7,279,641	227,354	9,488,174
Min	2,214,717	516,408	805,341	379,608	3,916,074
Const	3,777,071	4,295,333	4,991,407	5,458,971	18,522,782
Manu	2,256,153	3,007,187	3,464,827	3,767,980	12,496,147
TCPU	6,416,059	6,155,532	8,070,497	7,120,726	27,762,814
Whole	3,364,888	4,677,095	5,410,024	4,069,622	17,521,629
Retail	28,474,145	34,741,208	36,679,657	34,670,657	134,565,667
FIRE	3,439,155	3,667,615	3,373,799	3,049,232	13,529,801
Service	9,483,867	10,058,048	12,526,446	9,873,954	41,942,315
Govt	0	0	0	0	0
Total	60,596,369	67,929,291	82,601,639	68,618,104	279,745,403
2003					
AFF	1,002,650	838,734	10,272,676	470,121	12,584,181
Min	942,570	872,788	1,517,115	1,583,457	4,915,930
Const	4,091,798	6,395,590	7,848,712	12,186,606	30,522,706
Manu	2,997,006	4,210,293	5,529,544	2,258,019	14,994,862
TCPU	7,714,369	6,152,058	4,859,475	5,941,515	24,667,417
Whole	3,221,739	4,841,740	5,639,800	5,333,838	19,037,117
Retail	30,107,230	28,949,996	30,099,399	30,062,588	119,219,213
FIRE	3,084,600	3,326,119	3,155,128	3,374,705	12,940,552
Service	8,988,895	11,847,481	12,318,427	11,377,881	44,532,684
Govt	0	0	0	0	0
Total	62,150,857	67,434,799	81,240,276	72,588,730	283,414,662
2004					
AFF	1,061,786	1,296,885	12,241,519	1,749,704	16,349,894
Min	2,011,733	2,172,358	2,186,041	2,357,708	8,727,840
Const	2,270,541	2,705,601	3,619,374	4,181,316	12,776,832
Manu	1,610,022	3,062,848	2,757,875	2,075,696	9,506,441
TCPU	6,489,016	11,662,099	11,816,038	6,024,411	35,991,564
Whole	5,349,782	5,842,357	7,155,295	169,354,569	187,702,003
Retail	29,814,280	39,251,887	40,496,449	36,483,767	146,046,383
FIRE	2,918,854	3,294,005	3,445,709	3,436,985	13,095,553
Service	9,556,990	11,099,322	14,140,495	10,469,943	45,266,750
Govt	0	0	0	0	0
Total	61,083,004	80,387,362	97,858,795	236,134,099	475,463,260
2005					
					Year to Date
AFF	1,613,553	2,360,990	14,137,207		18,111,750
Min	2,243,621	1,068,085	3,231,706		6,543,412
Const	1,953,022	6,364,503	8,600,545		16,918,070
Manu	1,699,622	2,406,124	8,177,381		12,283,127
TCPU	20,315,610	28,241,441	8,825,948		57,382,999
Whole	4,974,303	6,590,438	7,171,027		18,735,768
Retail	30,495,186	40,309,307	42,831,723		113,636,216
FIRE	2,684,437	3,223,641	3,554,671		9,462,749
Service	9,562,814	10,873,764	14,763,810		35,200,388
Govt	0	0	0		0
Total	75,542,168	101,438,293	111,294,018		288,274,479

Table 3.19

Kenai Sales

Kenai TAXABLE Sales by Industry by Quarter - 2002-2005 - in \$					
	1st Quarter	2nd Quarter	3rd Quarter	4th Quarter	Total
2002					
AFF	90,609	128,556	200,238	86,211	505,614
Min	51,370	57,479	52,898	52,224	213,971
Const	248,573	273,401	292,612	296,515	1,111,101
Manu	349,360	622,875	754,966	491,314	2,218,515
TCPU	3,779,839	3,794,883	4,235,801	4,309,543	16,120,066
Whole	107,790	146,986	138,933	123,316	517,025
Retail	18,685,738	22,876,325	24,650,115	23,983,760	90,195,938
FIRE	1,645,401	1,684,226	1,706,454	1,564,165	6,600,246
Service	3,979,662	5,064,834	6,160,963	4,081,675	19,287,134
Govt	0	0	0	0	0
Total	28,938,342	34,649,565	38,192,980	34,988,723	136,769,610
2003					
AFF	87,894	134,783	237,344	99,292	559,313
Min	34,119	46,723	51,411	60,465	192,718
Const	236,553	294,469	312,562	308,985	1,152,569
Manu	441,292	687,335	816,883	506,419	2,451,929
TCPU	4,932,006	4,056,076	3,270,630	3,632,232	15,890,944
Whole	79,538	111,864	145,387	157,465	494,254
Retail	20,062,767	18,246,087	19,174,865	18,669,361	76,153,080
FIRE	1,496,823	1,506,804	1,387,466	1,271,988	5,663,081
Service	3,732,984	4,727,913	5,965,690	4,370,244	18,796,831
Govt	0	0	0	0	0
Total	31,103,976	29,812,054	31,362,238	29,076,451	121,354,719
2004					
AFF	97,275	159,363	351,638	110,139	718,415
Min	63,827	57,575	75,540	66,021	262,963
Const	263,404	291,079	307,561	262,293	1,124,337
Manu	508,762	803,910	1,023,087	517,323	2,853,082
TCPU	3,939,435	3,467,903	3,197,445	3,489,473	14,094,256
Whole	152,309	127,610	109,725	84,072	473,716
Retail	19,316,910	25,145,460	26,970,841	22,762,745	94,195,956
FIRE	1,273,853	1,359,412	1,373,838	1,272,081	5,279,184
Service	3,940,716	4,850,846	6,631,650	4,247,858	19,671,070
Govt	0	0	0	0	0
Total	29,556,491	36,263,158	40,041,325	32,812,005	138,672,979
2005					
					Year to Date
AFF	141,622	186,963	425,830		754,415
Min	70,218	46,396	52,988		169,602
Const	194,712	313,773	239,169		747,654
Manu	436,084	733,000	1,097,570		2,266,654
TCPU	3,897,696	3,320,405	3,378,215		10,596,316
Whole	90,018	126,121	123,876		340,015
Retail	19,579,438	26,397,732	29,088,247		75,065,417
FIRE	1,194,305	1,290,206	1,308,936		3,793,447
Service	3,911,829	4,984,415	6,925,412		15,821,656
Govt	0	0	0		0
Total	29,515,922	37,399,011	42,640,243		109,555,176

Table 3.20

Kenai Construction Permitting

Kenai 3rd Quarter Permit VALUES by Type - 1999-2005 - in \$								
	1999	2000	2001	2002	2003	2004	2005	Annual Change
Residential - New	1,049,000	1,287,000	1,152,000	2,899,000	560,000	1,197,500	1,544,000	28.9%
Residential - Add/Alter	267,000	387,000	217,500	302,400	168,850	308,950	306,600	-0.8%
Commercial - New	4,597,250	2,896,000	1,406,700	212,000	51,000	250,000	1,000,000	300.0%
Commercial - Add/Alter	209,400	524,000	1,730,000	3,400,600	2,920,500	235,300	1,184,500	403.4%
TOTAL	6,122,650	5,094,000	4,506,200	6,814,000	3,700,350	1,991,750	4,035,100	102.6%
Annual Change		-16.8%	-11.5%	51.2%	-45.7%	-46.2%	102.6%	

Table 3.21

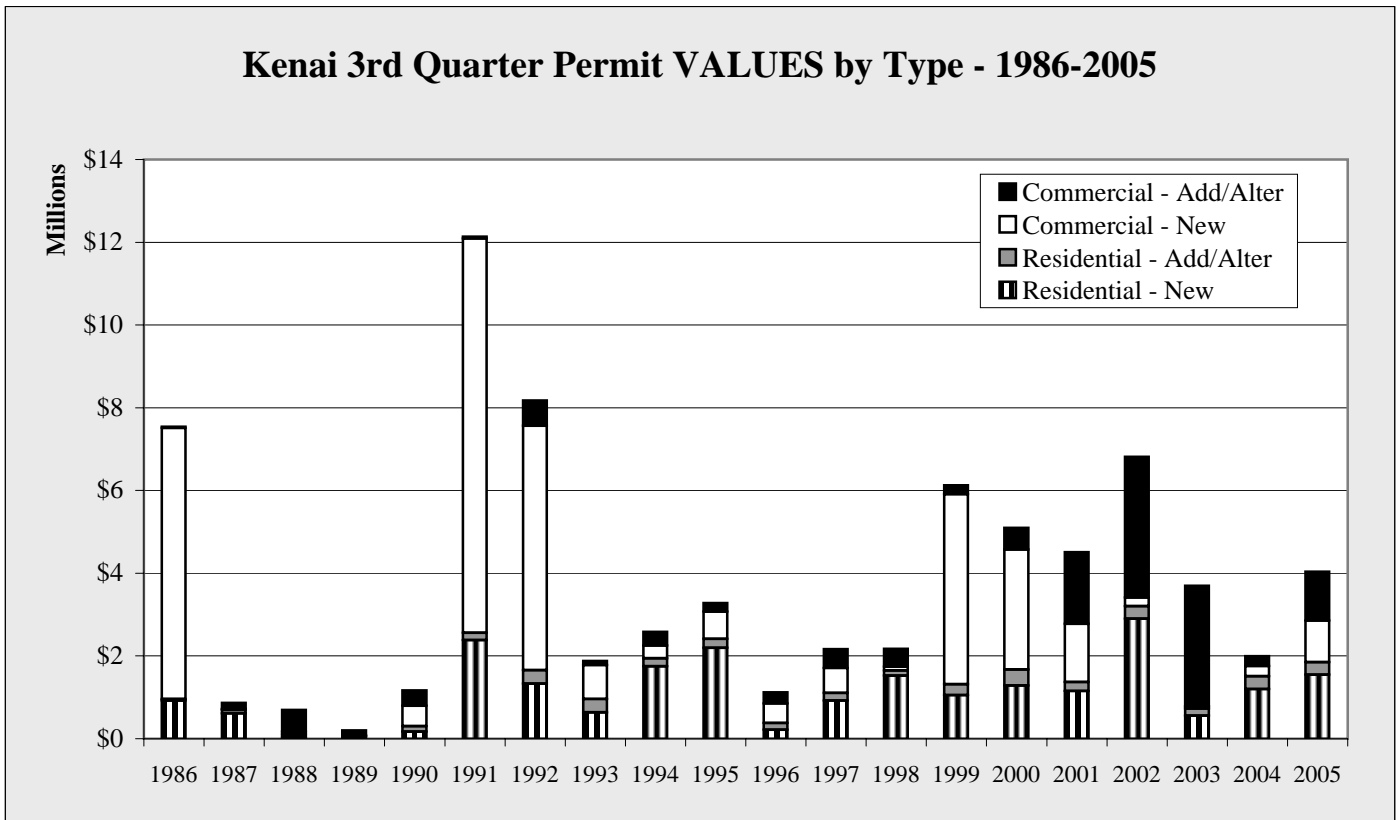

Chart 3.13

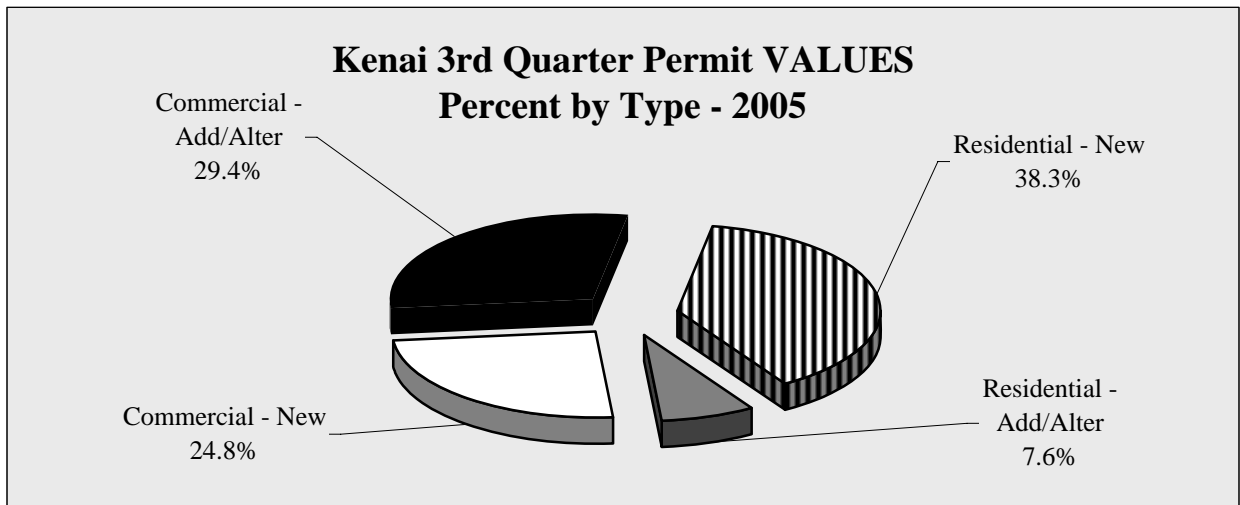

Chart 3.14

Kenai Construction Permitting

Kenai 3rd Quarter Permit VOLUME by Type - 1999-2005								
	1999	2000	2001	2002	2003	2004	2005	Annual Change
Residential - New	7	11	8	19	3	8	8	0.0%
Residential - Add/Alter	12	18	8	26	22	12	14	16.7%
Commercial - New	10	4	3	2	2	1	1	0.0%
Commercial - Add/Alter	11	3	4	12	18	10	10	0.0%
TOTAL	40	36	23	59	45	31	33	6.5%
Annual Change		-10.0%	-36.1%	156.5%	-23.7%	-31.1%	6.5%	

Table 3.22

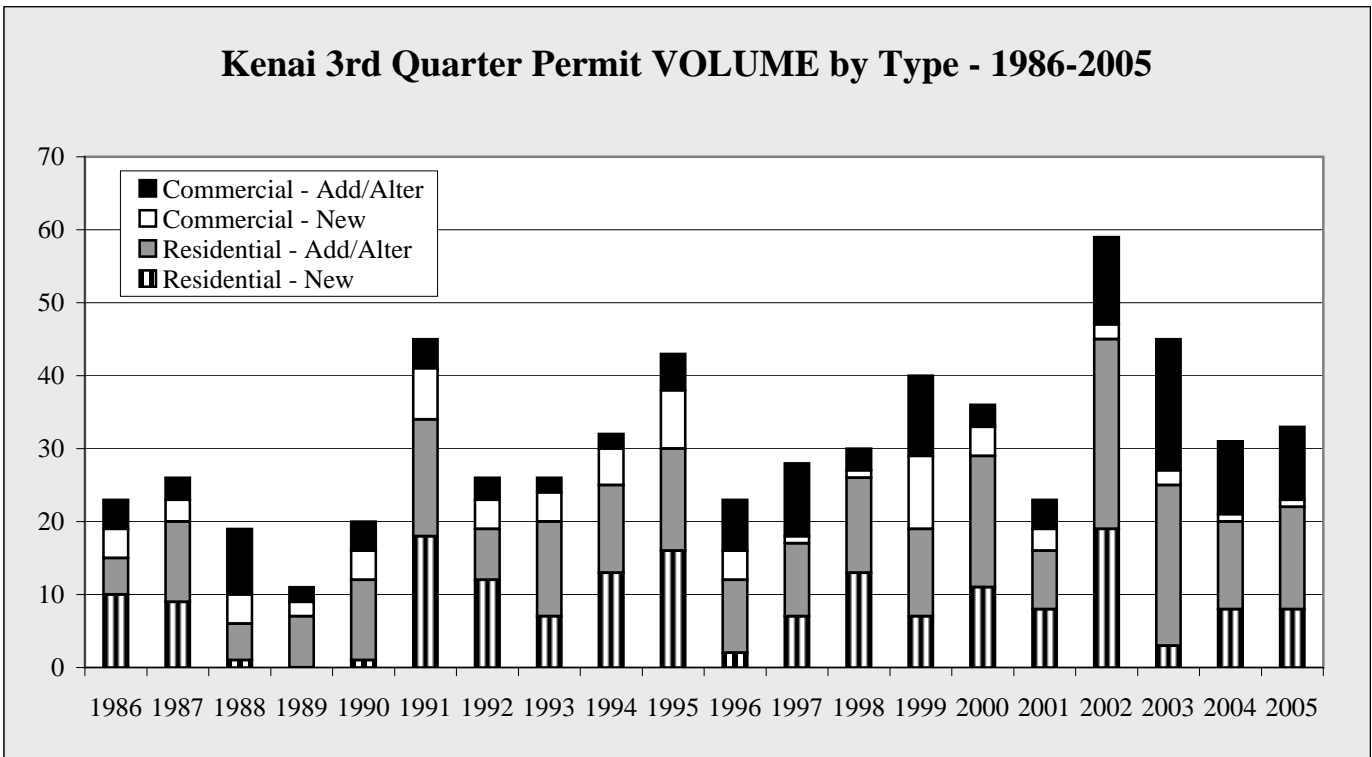

Chart 3.15

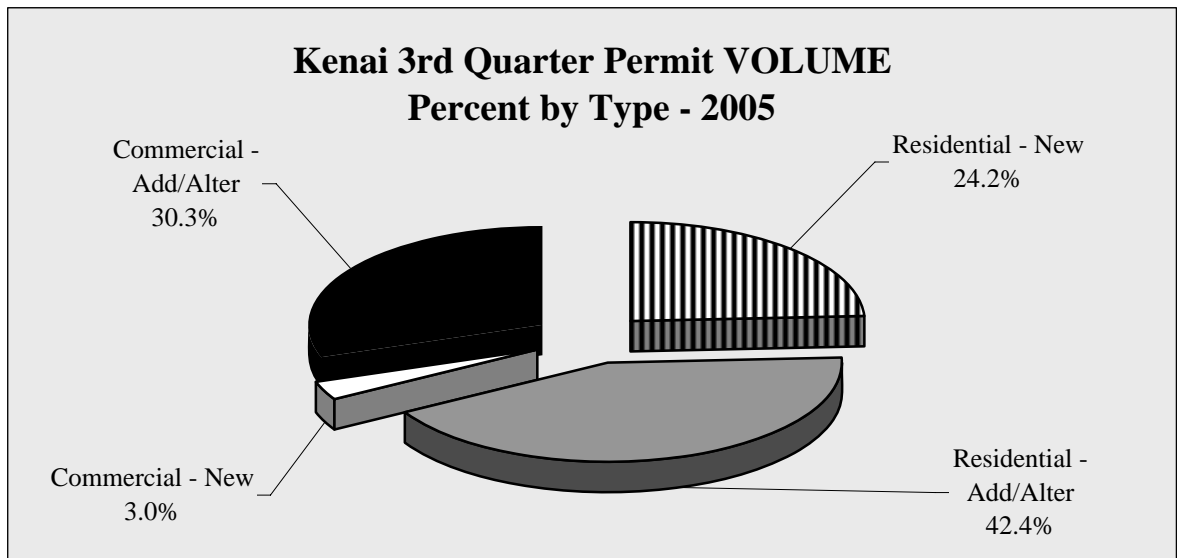

Chart 3.16

Kenai Construction Permitting

Kenai YTD 9/30 Permit VALUES by Type - 1999-2005 - in \$								
	1999	2000	2001	2002	2003	2004	2005	Annual Change
Residential - New	2,622,000	3,121,000	4,661,000	5,540,000	2,503,000	2,576,500	3,427,500	33.0%
Residential - Add/Alter	576,600	833,000	607,300	653,500	699,050	373,150	572,400	53.4%
Commercial - New	4,672,750	4,006,000	5,165,700	5,271,200	51,000	331,000	1,045,000	215.7%
Commercial - Add/Alter	513,400	759,900	2,489,600	3,806,900	4,733,250	920,500	1,973,000	114.3%
TOTAL	8,384,750	8,719,900	12,923,600	15,271,600	7,986,300	4,201,150	7,017,900	67.0%
Annual Change		4.0%	48.2%	18.2%	-47.7%	-47.4%	67.0%	

Table 3.23

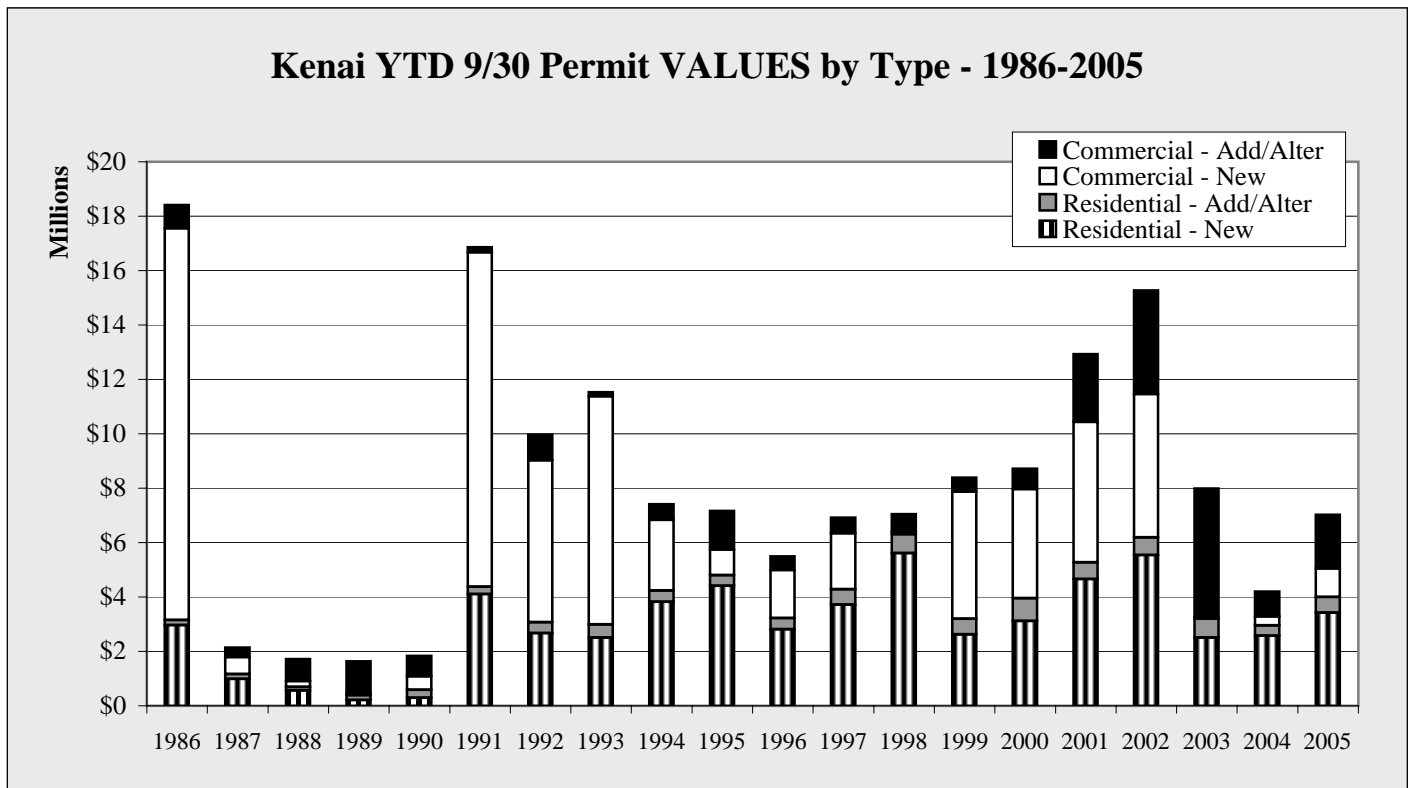

Chart 3.17

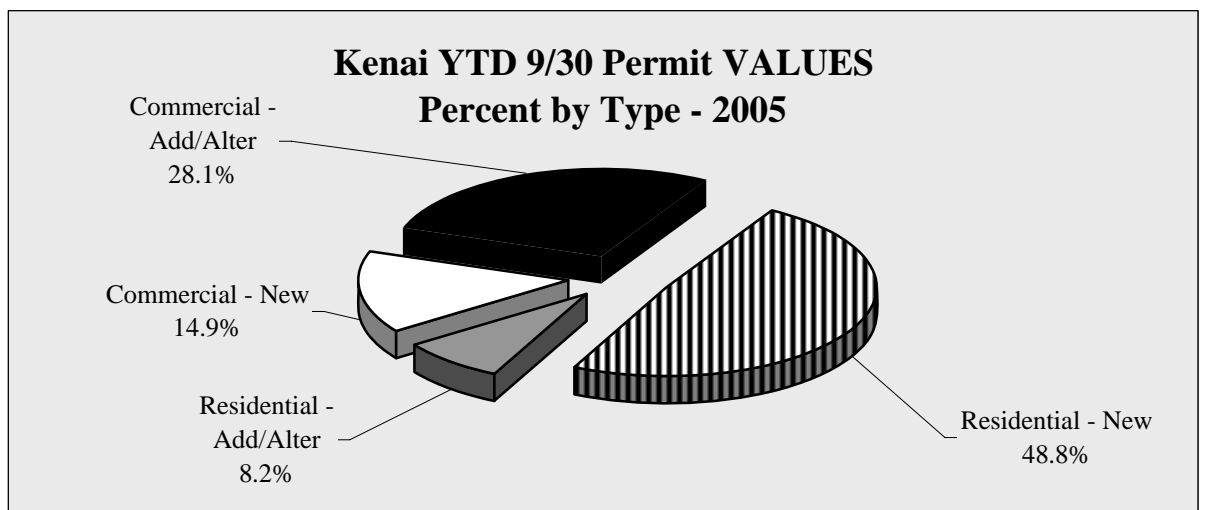

Chart 3.18

Kenai Construction Permitting

Kenai YTD 9/30 Permit VOLUME by Type - 1999-2005

	1999	2000	2001	2002	2003	2004	2005	Annual Change
Residential - New	19	23	28	39	16	16	19	18.8%
Residential - Add/Alter	28	38	26	41	39	21	32	52.4%
Commercial - New	12	9	7	6	2	3	3	0.0%
Commercial - Add/Alter	21	10	15	15	36	25	22	-12.0%
TOTAL	80	80	76	101	93	65	76	16.9%
Annual Change		0.0%	-5.0%	32.9%	-7.9%	-30.1%	16.9%	

Table 3.24

Kenai YTD 9/30 Permit VOLUME by Type - 1986-2005

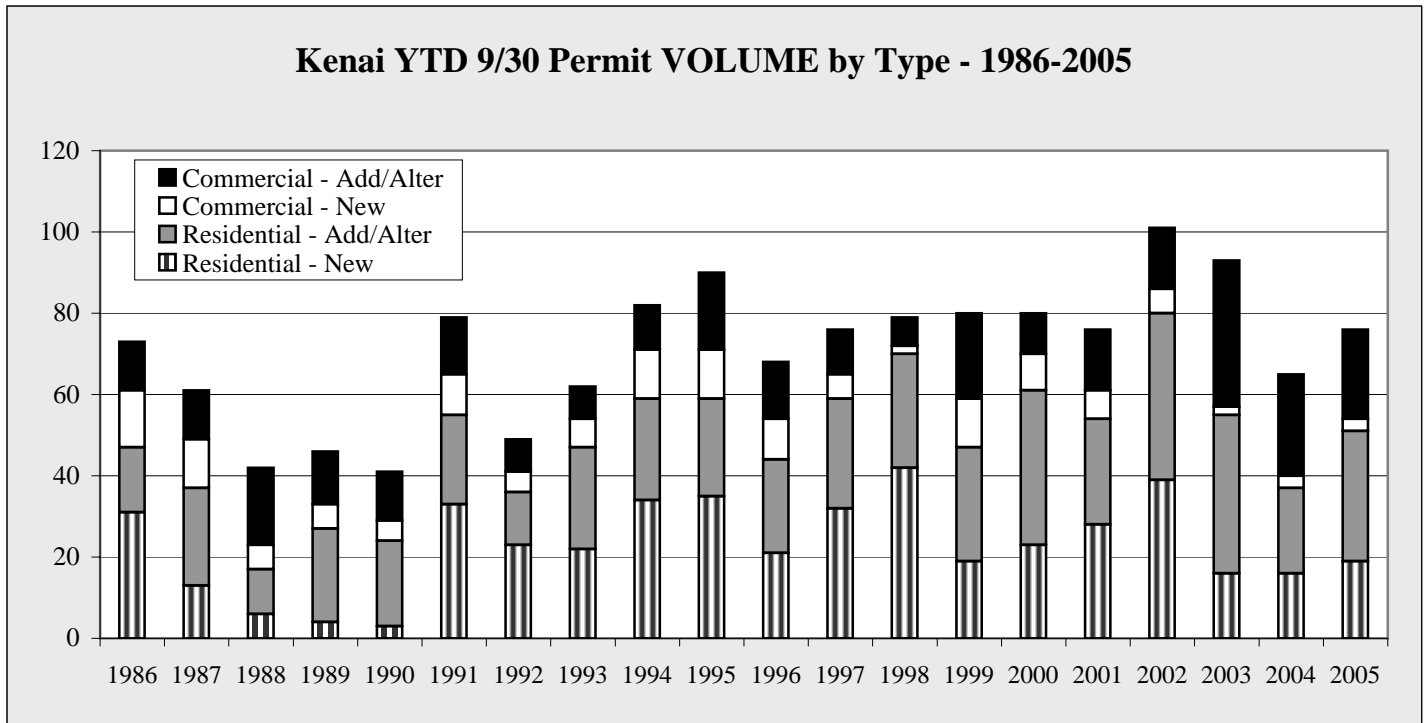

Chart 3.19

**Kenai YTD 9/30 Permit VOLUME
Percent by Type - 2005**

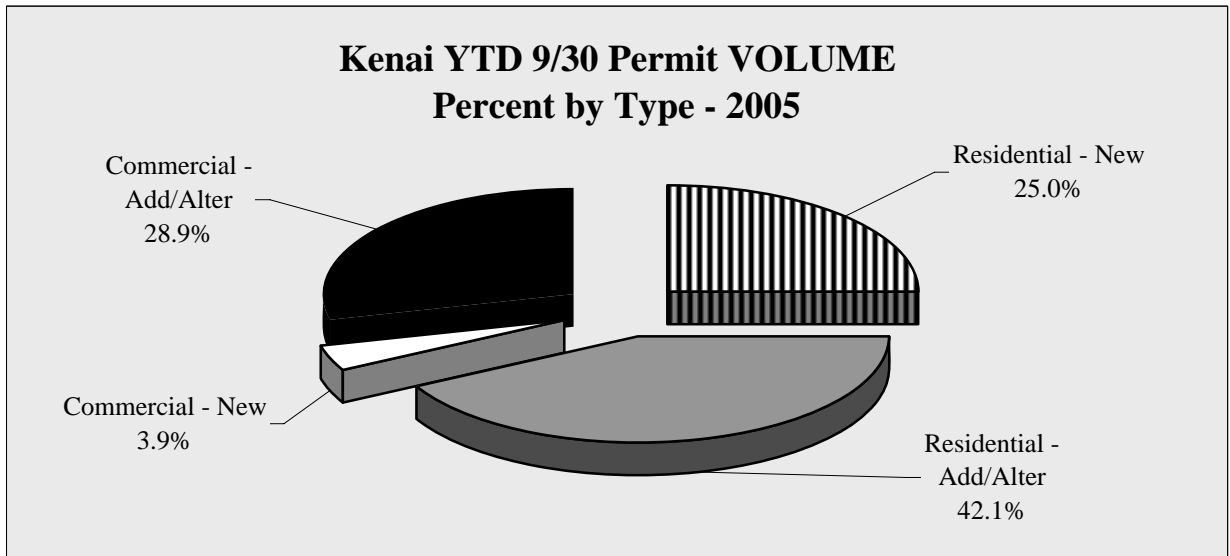

Chart 3.20

Kenai Construction Permitting

Kenai Annual Permit VALUES by Type - 1998-2004 - in \$

	1998	1999	2000	2001	2002	2003	2004	Annual Change
Residential - New	6,033,500	3,324,000	3,497,000	4,985,000	5,917,000	3,282,000	3,058,500	-6.8%
Residential - Add/Alter	730,700	798,000	888,400	675,100	723,500	882,050	400,150	-54.6%
Commercial - New	151,000	4,797,750	4,250,000	5,379,700	6,261,200	304,000	331,000	8.9%
Commercial - Add/Alter	727,000	522,000	762,700	2,539,100	3,897,700	5,973,750	996,900	-83.3%
TOTAL	7,642,200	9,441,750	9,398,100	13,578,900	16,799,400	10,441,800	4,786,550	-54.2%
Annual Change		23.5%	-0.5%	44.5%	23.7%	-37.8%	-54.2%	

Table 3.25

Kenai Annual Permit VALUES by Type - 1986-2004

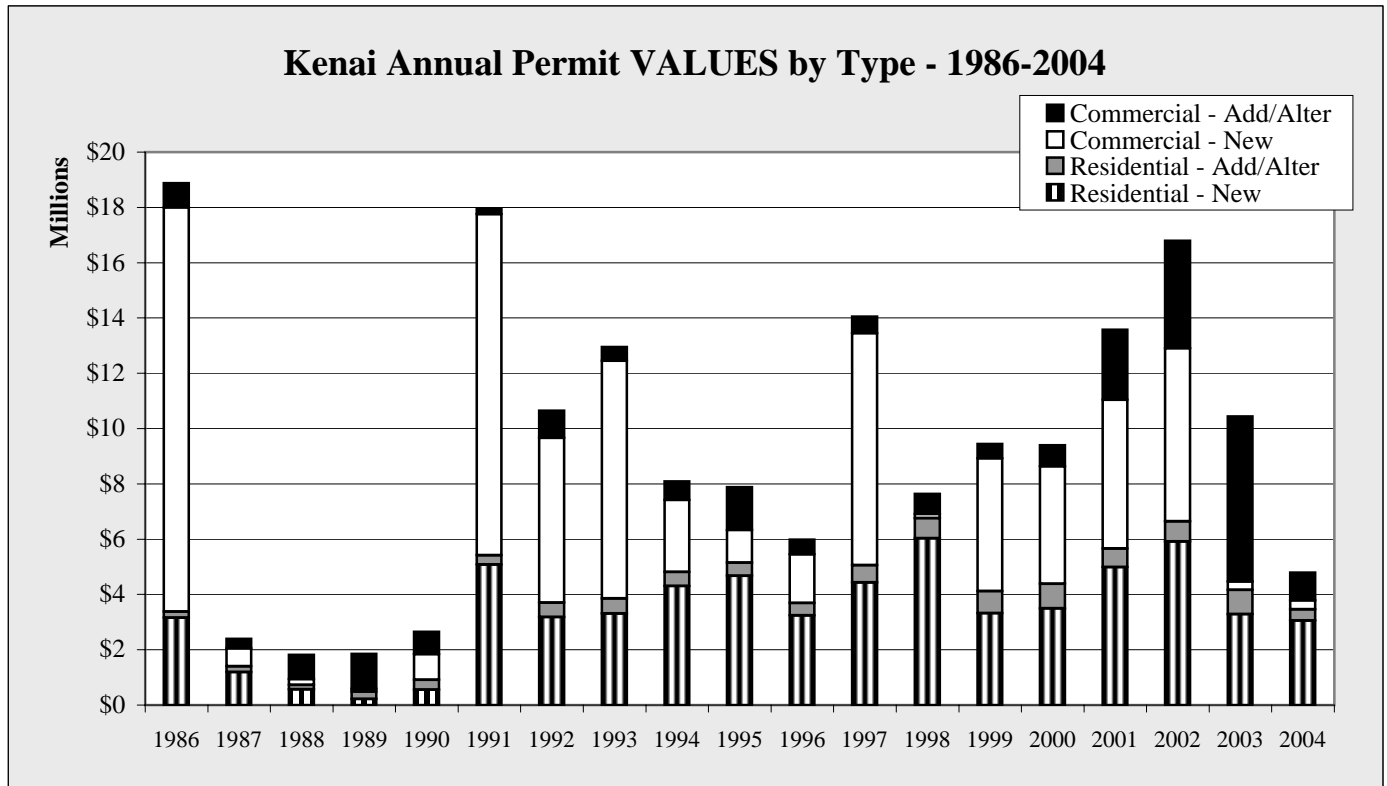

Chart 3.21

**Kenai Annual Permit VALUES
Percent by Type - 2004**

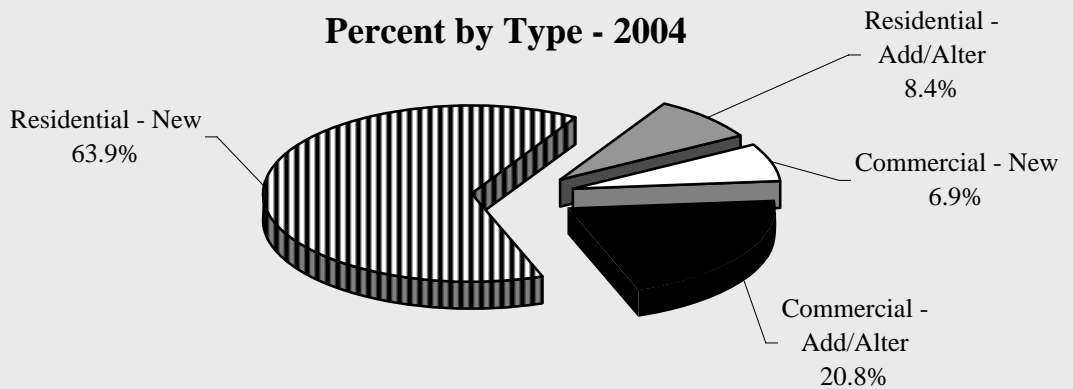

Chart 3.22

Kenai Construction Permitting

Kenai Annual Permit VOLUME by Type - 1998-2004

	1998	1999	2000	2001	2002	2003	2004	Annual Change
Residential - New	45	26	26	30	42	22	20	-9.1%
Residential - Add/Alter	33	41	45	31	45	44	25	-43.2%
Commercial - New	4	13	11	8	9	4	3	-25.0%
Commercial - Add/Alter	15	22	11	18	25	44	31	-29.5%
TOTAL	97	102	93	87	121	114	79	-30.7%
Annual Change		5.2%	-8.8%	-6.5%	39.1%	-5.8%	-30.7%	

Table 3.26

Kenai Annual Permit VOLUME by Type - 1986-2004

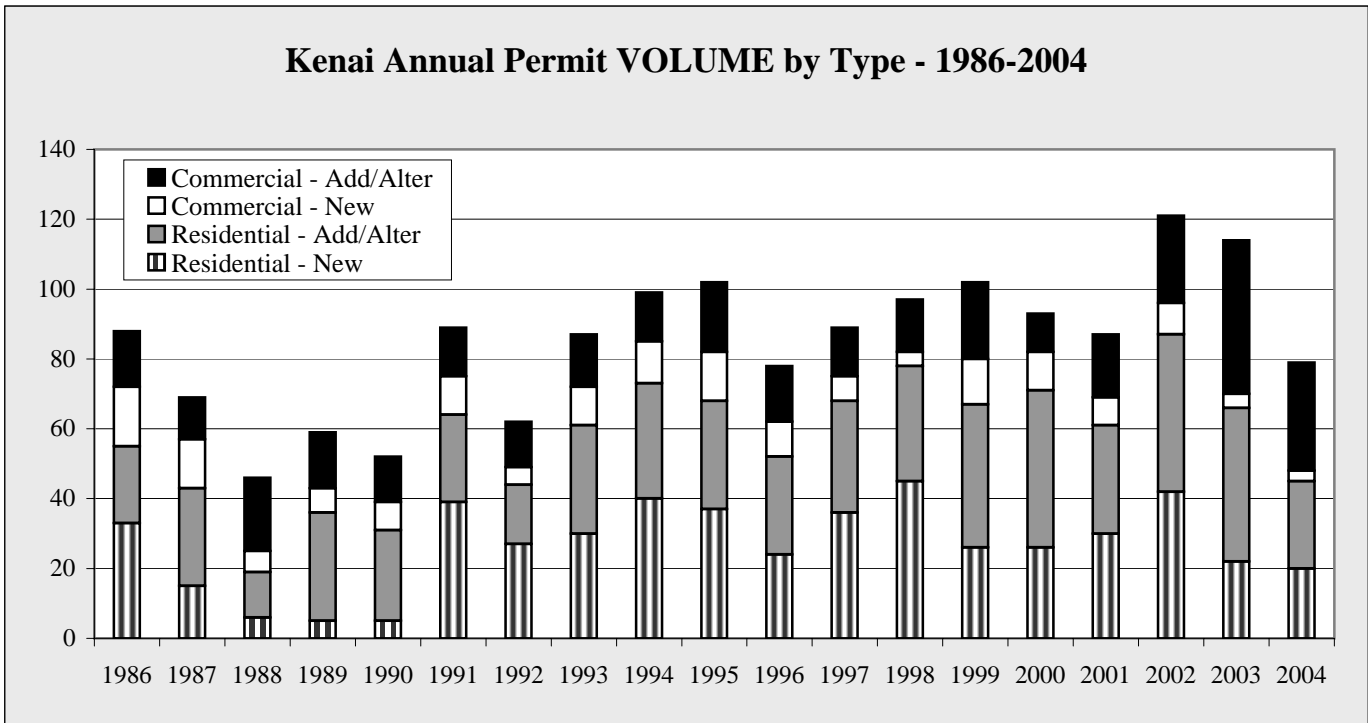

Chart 3.23

**Kenai Annual Permit VOLUME
Percent by Type - 2004**

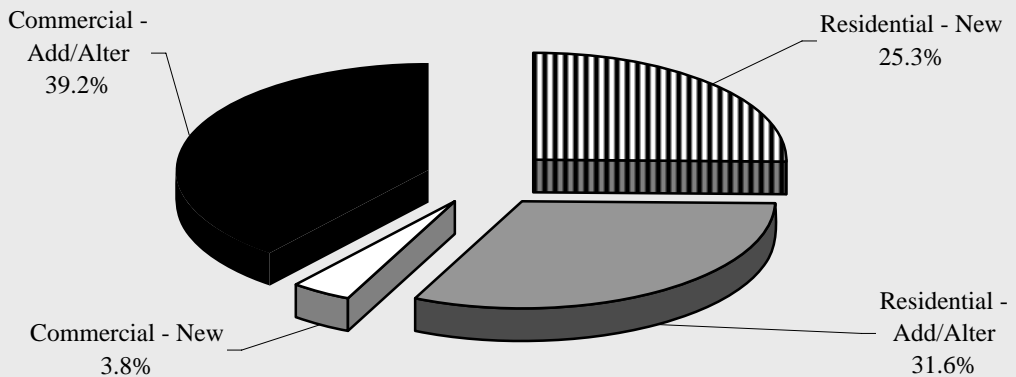

Chart 3.24

Kenai Construction Permitting

Kenai Annual Permit VALUES by Type by Quarter - 1998-2005 - in \$					
	1st Quarter	2nd Quarter	3rd Quarter	4th Quarter	Total
1998					
Residential - New	208,500	3,884,500	1,524,500	416,000	6,033,500
Residential - Add/Alter	68,500	495,500	122,900	43,800	730,700
Commercial - New	7,000	0	95,000	49,000	151,000
Commercial - Add/Alter	186,500	21,500	432,500	86,500	727,000
TOTAL	470,500	4,401,500	2,174,900	595,300	7,642,200
1999					
Residential - New	0	1,573,000	1,049,000	702,000	3,324,000
Residential - Add/Alter	122,000	187,600	267,000	221,400	798,000
Commercial - New	14,500	61,000	4,597,250	125,000	4,797,750
Commercial - Add/Alter	103,000	201,000	209,400	8,600	522,000
TOTAL	239,500	2,022,600	6,122,650	1,057,000	9,441,750
2000					
Residential - New	228,000	1,606,000	1,287,000	376,000	3,497,000
Residential - Add/Alter	7,000	439,000	387,000	55,400	888,400
Commercial - New	65,000	1,045,000	2,896,000	244,000	4,250,000
Commercial - Add/Alter	162,900	73,000	524,000	2,800	762,700
TOTAL	462,900	3,163,000	5,094,000	678,200	9,398,100
2001					
Residential - New	623,000	2,886,000	1,152,000	324,000	4,985,000
Residential - Add/Alter	161,500	228,300	217,500	67,800	675,100
Commercial - New	15,000	3,744,000	1,406,700	214,000	5,379,700
Commercial - Add/Alter	20,000	739,600	1,730,000	49,500	2,539,100
TOTAL	819,500	7,597,900	4,506,200	655,300	13,578,900
2002					
Residential - New	279,000	2,362,000	2,899,000	377,000	5,917,000
Residential - Add/Alter	28,000	323,100	302,400	70,000	723,500
Commercial - New	3,579,200	1,480,000	212,000	990,000	6,261,200
Commercial - Add/Alter	2,000	404,300	3,400,600	90,800	3,897,700
TOTAL	3,888,200	4,569,400	6,814,000	1,527,800	16,799,400
2003					
Residential - New	0	1,943,000	560,000	779,000	3,282,000
Residential - Add/Alter	15,000	515,200	168,850	183,000	882,050
Commercial - New	0	0	51,000	253,000	304,000
Commercial - Add/Alter	1,542,600	270,150	2,920,500	1,240,500	5,973,750
TOTAL	1,557,600	2,728,350	3,700,350	2,455,500	10,441,800
2004					
Residential - New	300,000	1,079,000	1,197,500	482,000	3,058,500
Residential - Add/Alter	12,000	52,200	308,950	27,000	400,150
Commercial - New	0	81,000	250,000	0	331,000
Commercial - Add/Alter	0	685,200	235,300	76,400	996,900
TOTAL	312,000	1,897,400	1,991,750	585,400	4,786,550
2005					
					Year to Date
Residential - New	0	1,883,500	1,544,000		3,427,500
Residential - Add/Alter	134,500	131,300	306,600		572,400
Commercial - New	0	45,000	1,000,000		1,045,000
Commercial - Add/Alter	291,000	497,500	1,184,500		1,973,000
TOTAL	425,500	2,557,300	4,035,100		7,017,900

Table 3.27

Kenai Construction Permitting

Kenai Annual Permit VOLUME by Type by Quarter - 1998-2005					
	1st Quarter	2nd Quarter	3rd Quarter	4th Quarter	Total
1998					
Residential - New	2	27	13	3	45
Residential - Add/Alter	5	10	13	5	33
Commercial - New	1	0	1	2	4
Commercial - Add/Alter	2	2	3	8	15
TOTAL	10	39	30	18	97
1999					
Residential - New	0	12	7	7	26
Residential - Add/Alter	3	13	12	13	41
Commercial - New	1	1	10	1	13
Commercial - Add/Alter	3	7	11	1	22
TOTAL	7	33	40	22	102
2000					
Residential - New	1	11	11	3	26
Residential - Add/Alter	2	18	18	7	45
Commercial - New	1	4	4	2	11
Commercial - Add/Alter	4	3	3	1	11
TOTAL	8	36	36	13	93
2001					
Residential - New	4	16	8	2	30
Residential Add/Alter	5	13	8	5	31
Commercial - New	1	3	3	1	8
Commercial - Add/Alter	1	10	4	3	18
TOTAL	11	42	23	11	87
2002					
Residential - New	2	18	19	3	42
Residential Add/Alter	1	14	26	4	45
Commercial - New	1	3	2	3	9
Commercial - Add/Alter	1	2	12	10	25
TOTAL	5	37	59	20	121
2003					
Residential - New	0	13	3	6	22
Residential Add/Alter	1	16	22	5	44
Commercial - New	0	0	2	2	4
Commercial - Add/Alter	7	11	18	8	44
TOTAL	8	40	45	21	114
2004					
Residential - New	3	5	8	4	20
Residential Add/Alter	1	8	12	4	25
Commercial - New	0	2	1	0	3
Commercial - Add/Alter	0	15	10	6	31
TOTAL	4	30	31	14	79
2005					
					Year to Date
Residential - New	0	11	8		19
Residential Add/Alter	7	11	14		32
Commercial - New	0	2	1		3
Commercial - Add/Alter	3	9	10		22
TOTAL	10	33	33		76

Table 3.28

Kenai Cost of Food

Cost of food data is collected by the University of Alaska, Fairbanks Cooperative Extension. Each quarter the Cooperative Extension surveys up to three grocers in communities throughout the state to determine the cost of food for one week. Specific guidelines are presented to the surveyors regarding item size and sale price for 104 items. Because separation of Kenai and Soldotna data would be meaningless, data presented relates to both communities.

KENAI/SOLDOTNA											
	Sept 1996	Sept 1997	Sept 1998	Sept 1999	Sept 2000	Sept 2001	Sept 2002	Sept 2003	Sept 2004	Sept 2005	Annual Change
Sales Tax (in percent)	5.0	5.0	5.0	5.0	5.0	5.0	5.0	5.0	5.0	5.0	
Percent of Food Unavailable	0.0	0.0	0.0	0.0	1.0	1.0	1.0	0.0	0.0	0.0	
Child, 1 year	15.78	15.70	15.51	16.43	16.63	17.79	17.63	18.33	19.02	19.06	0.2%
Child, 2 years	0.00	0.00	0.00	0.00	0.00	17.79	17.63	18.33	18.82	18.35	-2.5%
Children 3-5 years of age	17.30	17.16	17.02	17.98	18.34	19.56	19.36	19.97	20.78	20.76	-0.1%
Children 6-8 years of age	22.90	22.77	22.64	23.91	24.34	26.02	25.87	26.71	27.77	27.95	0.6%
Children 9-11 years of age	25.99	25.87	25.65	27.09	27.60	29.47	29.35	30.16	31.36	31.53	0.5%
Males 12-14 years of age	29.37	29.24	29.01	30.62	31.28	33.37	33.16	34.05	35.45	35.62	0.5%
Males 15-19 years of age	30.28	30.19	29.85	31.48	32.22	34.43	34.20	35.09	36.41	36.71	0.8%
Males 20-50 years of age	29.92	29.93	29.76	31.31	32.05	34.25	34.12	35.01	36.49	36.68	0.5%
Males 51 and older	28.52	28.63	28.42	29.76	30.51	32.47	32.48	33.37	34.73	34.84	0.3%
Females 12-19 years of age	25.29	25.18	24.98	26.32	26.91	28.75	28.47	29.38	30.54	30.73	0.6%
Females 20-50 years of age	26.20	26.30	26.07	27.27	28.02	29.82	29.77	30.52	31.76	31.90	0.4%
Females 51 and older	25.39	25.44	25.24	26.58	27.17	29.02	28.91	29.64	30.90	31.00	0.3%
Family of 2, 20-50 years of age	61.72	61.84	61.45	64.42	66.08	70.48	70.29	72.09	75.08	75.42	0.5%
Family of 2, 51 years and older	59.29	59.51	59.02	62.01	63.42	67.64	67.52	69.31	72.20	72.43	0.3%
Family of 4, children 1-5 years	89.19	89.09	88.37	92.98	95.04	101.42	100.89	103.64	107.86	108.17	0.3%
Family of 4, children 6-11 years	105.01	104.87	104.13	109.58	112.01	119.55	119.12	122.39	127.38	128.05	0.5%
Electricity, 1000 kWh	111.00	111.00	120.65	119.34	113.23	122.05	126.15	113.80	121.35	135.08	11.3%
Gasoline, auto, 55 gal	72.60	75.85	76.18	78.65	93.78	93.78	87.45	103.68	115.50	156.20	35.2%
Lumber, 2X4X8'	4.01	3.51	3.29	3.50	3.26	3.50	3.31	3.42	3.54	2.95	-16.7%
Propane, 100 lb. refill	38.20	39.48	38.68	34.93	41.77	0.00	43.42	48.14	51.92	59.00	13.6%
Sewer & Water, monthly	41.29	41.29	41.29								

Table 3.29

Kenai Cost of Food

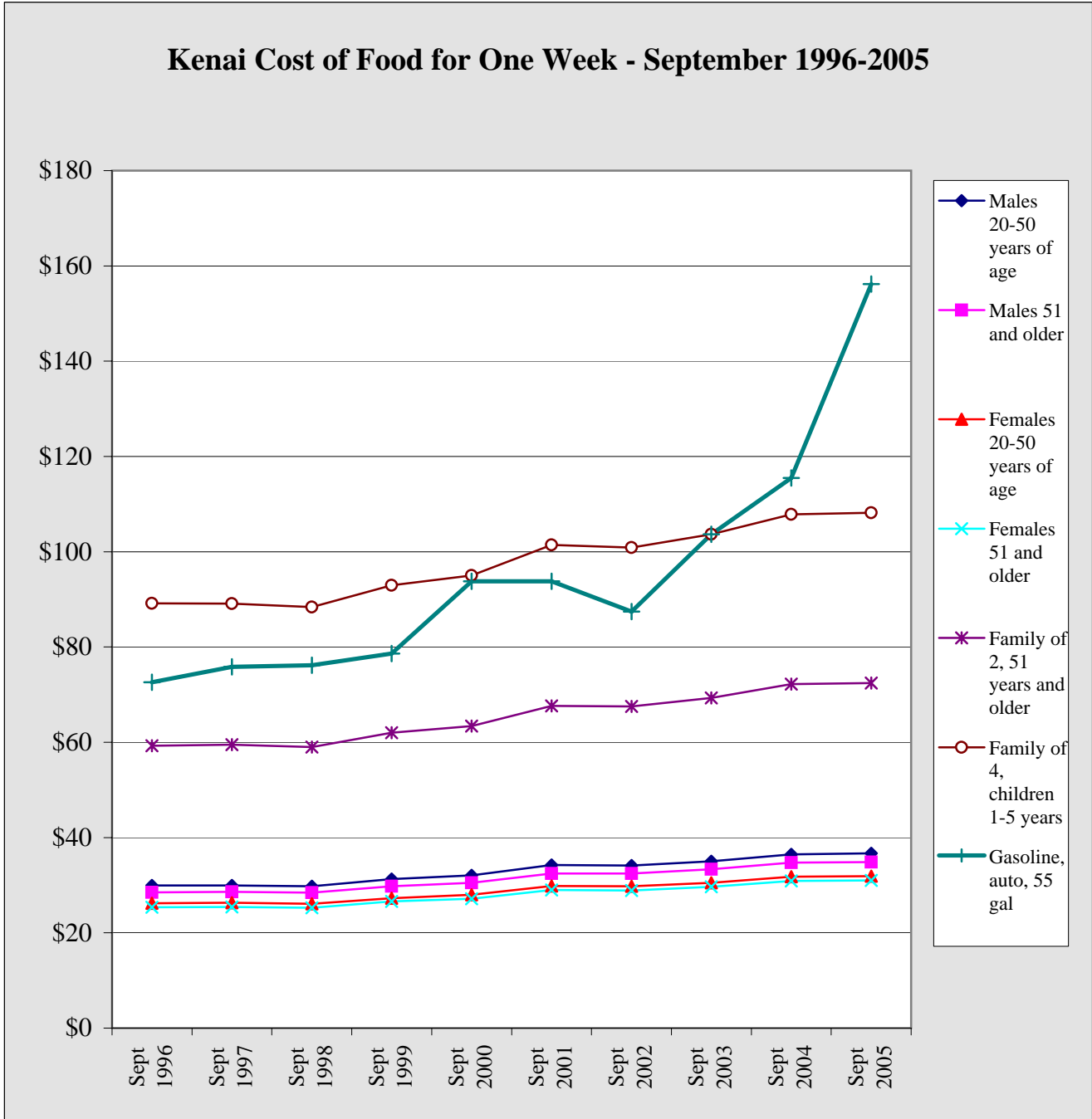

Chart 3.25

Seldovia Sales

Seldovia 3rd Quarter GROSS Sales by Industry - 1999-2005 - in \$								
	1999	2000	2001	2002	2003	2004	2005	Annual Change
AFF	479	0	80	0	0	17,500	0	NA
Min	0	0	0	0	0	0	0	NA
Const	101,982	165,256	65,667	84,321	1,256,705	360,893	443,920	23.0%
Manu	127,613	1,710	22,581	2,556	14,320	12,786	36,279	183.7%
TCPU	167,976	169,243	167,386	137,154	137,236	168,520	172,707	2.5%
Whole	110,895	23,370	12,723	22,402	71,441	30,407	20,608	-32.2%
Retail	807,058	888,589	835,067	825,256	768,860	762,079	899,480	18.0%
FIRE	24,267	8,573	458,280	220,225	91,073	14,447	239,994	1561.2%
Service	366,916	436,895	395,770	402,260	494,150	442,435	420,786	-4.9%
Total	1,707,186	1,693,636	1,957,554	1,694,174	2,833,785	1,809,067	2,233,774	23.5%
Annual Change		-0.8%	15.6%	-13.5%	67.3%	-36.2%	23.5%	

Table 4.1

Seldovia 3rd Quarter GROSS Sales Ten Year Change by INDUSTRY - 1995 v. 2005 - in \$				
	10 Year Change			
	1995	2005	Percentage	Numerical
AFF	0	0	0.0%	0
Min	0	0	0.0%	0
Const	105,492	443,920	320.8%	338,428
Manu	113,188	36,279	-67.9%	-76,909
TCPU	149,013	172,707	15.9%	23,694
Whole	440,173	20,608	-95.3%	-419,565
Retail	580,893	899,480	54.8%	318,587
FIRE	33,028	239,994	626.6%	206,966
Service	447,321	420,786	-5.9%	-26,535
Total	1,869,108	2,233,774	19.5%	364,666

Table 4.2

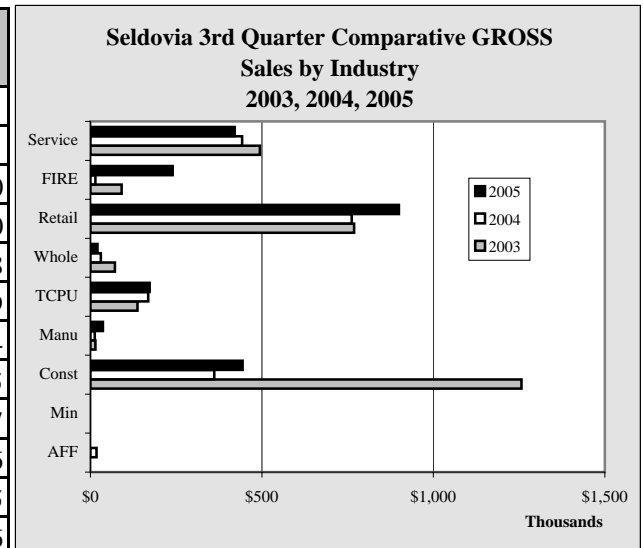

Chart 4.1

Seldovia 3rd Quarter GROSS Sales One Year Change by INDUSTRY - 2004 v. 2005 - in \$				
	1 Year Change			
	2004	2005	Percentage	Numerical
AFF	17,500	0	-100.0%	-17,500
Min	0	0	0.0%	0
Const	360,893	443,920	23.0%	83,027
Manu	12,786	36,279	183.7%	23,493
TCPU	168,520	172,707	2.5%	4,187
Whole	30,407	20,608	-32.2%	-9,799
Retail	762,079	899,480	18.0%	137,401
FIRE	14,447	239,994	1561.2%	225,547
Service	442,435	420,786	-4.9%	-21,649
Total	1,809,067	2,233,774	23.5%	424,707

Table 4.3

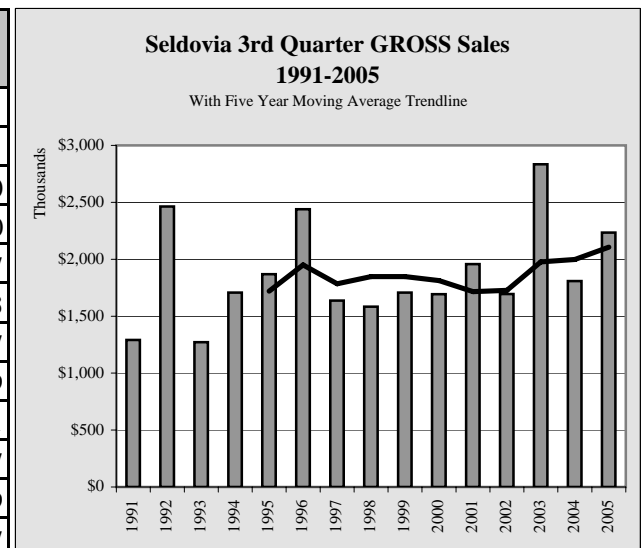

Chart 4.2

Seldovia Sales

Seldovia 3rd Quarter TAXABLE Sales by Industry - 1999-2005 - in \$								
	1999	2000	2001	2002	2003	2004	2005	Annual Change
AFF	479	0	0	0	0	0	0	NA
Min	0	0	0	0	0	0	0	NA
Const	11,774	9,699	9,793	5,551	6,900	7,520	5,866	-22.0%
Manu	2,534	508	2,047	655	6,036	4,964	5,922	19.3%
TCPU	124,855	120,362	105,304	106,236	107,036	118,010	114,015	-3.4%
Whole	2,468	403	1,416	651	640	131	81	-38.2%
Retail	660,500	758,922	751,665	754,759	693,503	698,936	743,415	6.4%
FIRE	19,232	4,157	10,190	7,535	7,783	10,589	18,433	74.1%
Service	322,785	347,057	327,110	316,602	318,421	341,988	311,809	-8.8%
Total	1,144,627	1,241,108	1,207,525	1,191,989	1,140,319	1,182,138	1,199,541	1.5%
Annual Change		8.4%	-2.7%	-1.3%	-4.3%	3.7%	1.5%	

Table 4.4

Seldovia 3rd Quarter TAXABLE Sales Ten Year Change by INDUSTRY - 1995 v. 2005 - in \$				
	10 Year Change			
	1995	2005	Percentage	Numerical
AFF	0	0	0.0%	0
Min	0	0	0.0%	0
Const	3,799	5,866	54.4%	2,067
Manu	51,377	5,922	-88.5%	-45,455
TCPU	111,157	114,015	2.6%	2,858
Whole	185,097	81	-100.0%	-185,016
Retail	542,060	743,415	37.1%	201,355
FIRE	30,303	18,433	-39.2%	-11,870
Service	382,900	311,809	-18.6%	-71,091
Total	1,306,693	1,199,541	-8.2%	-107,152

Table 4.5

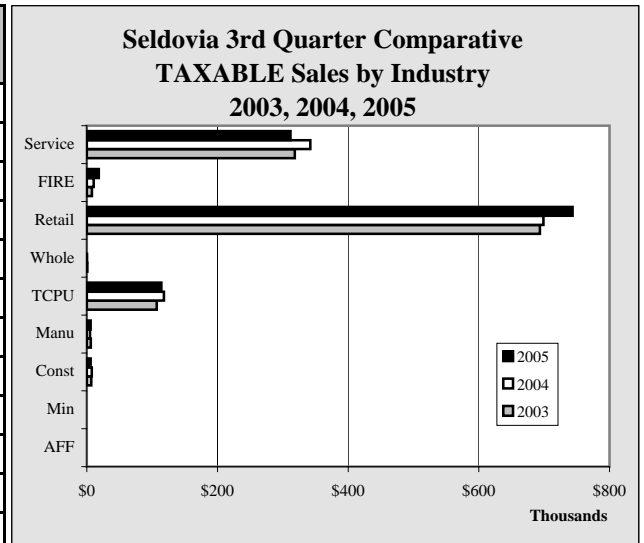

Chart 4.3

Seldovia 3rd Quarter TAXABLE Sales One Year Change by INDUSTRY - 2004 v. 2005 - in \$				
	1 Year Change			
	2004	2005	Percentage	Numerical
AFF	0	0	0.0%	0
Min	0	0	0.0%	0
Const	7,520	5,866	-22.0%	-1,654
Manu	4,964	5,922	19.3%	958
TCPU	118,010	114,015	-3.4%	-3,995
Whole	131	81	-38.2%	-50
Retail	698,936	743,415	6.4%	44,479
FIRE	10,589	18,433	74.1%	7,844
Service	341,988	311,809	-8.8%	-30,179
Total	1,182,138	1,199,541	1.5%	17,403

Table 4.6

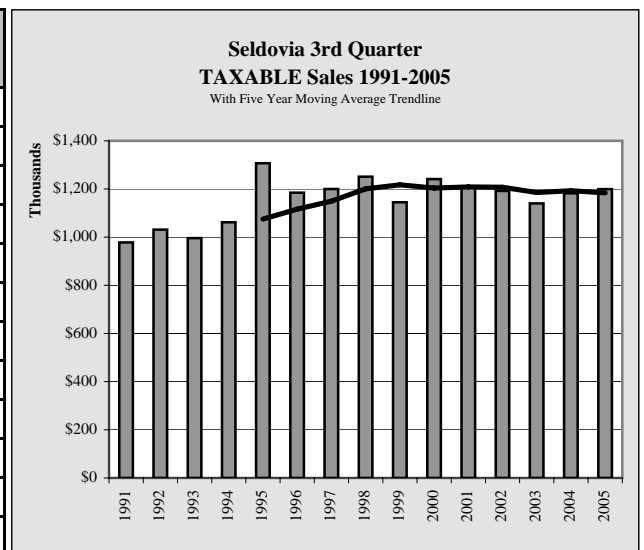

Chart 4.4

Seldovia Sales

Seldovia YTD 9/30 GROSS Sales by Industry - 1999-2005 - in \$								
	1999	2000	2001	2002	2003	2004	2005	Annual Change
AFF	3,084	2,797	3,787	6,306	5,737	28,760	0	-100.0%
Min	0	0	0	0	0	0	0	NA
Const	147,557	460,964	382,718	193,822	1,498,427	1,725,904	1,290,374	-25.2%
Manu	139,507	12,083	40,000	10,171	41,491	22,770	74,501	227.2%
TCPU	539,074	491,672	468,039	436,778	420,565	472,346	511,132	8.2%
Whole	448,070	62,787	51,899	33,202	98,119	70,794	68,777	-2.8%
Retail	1,846,820	2,448,774	2,147,430	2,000,950	2,024,538	2,007,402	2,178,175	8.5%
FIRE	95,336	47,386	499,110	387,627	340,351	33,744	680,123	1915.5%
Service	783,984	844,765	736,687	792,085	881,017	824,064	812,308	-1.4%
Total	4,003,432	4,371,228	4,329,670	3,860,941	5,310,245	5,185,784	5,615,390	8.3%
Annual Change		9.2%	-1.0%	-10.8%	37.5%	-2.3%	8.3%	

Table 4.7

Seldovia YTD 9/30 GROSS Sales Ten Year Change by INDUSTRY - 1995 v. 2005 - in \$				
			10 Year Change	
	1995	2005	Percentage	Numerical
AFF	2,573	0	-100.0%	-2,573
Min	2,789	0	-100.0%	-2,789
Const	255,848	1,290,374	404.4%	1,034,526
Manu	120,369	74,501	-38.1%	-45,868
TCPU	477,022	511,132	7.2%	34,110
Whole	1,341,747	68,777	-94.9%	-1,272,970
Retail	1,281,771	2,178,175	69.9%	896,404
FIRE	136,823	680,123	397.1%	543,300
Service	1,015,639	812,308	-20.0%	-203,331
Total	4,634,581	5,615,390	0.0%	980,809

Table 4.8

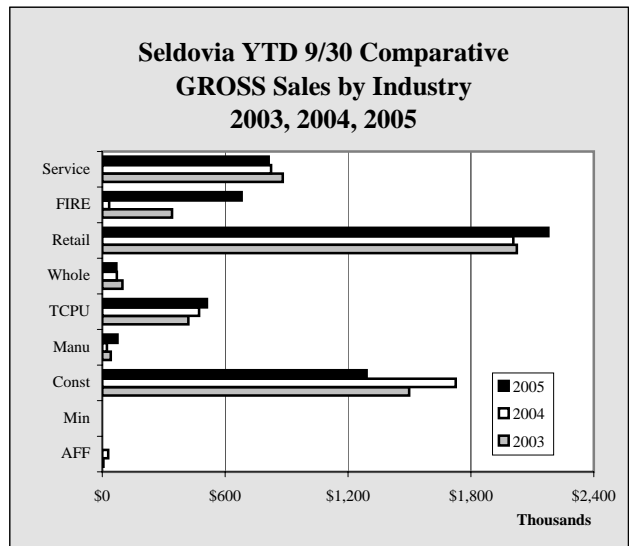

Chart 4.5

Seldovia YTD 9/30 GROSS Sales One Year Change by INDUSTRY - 2004 v. 2005 - in \$				
			1 Year Change	
	2004	2005	Percentage	Numerical
AFF	28,760	0	-100.0%	-28,760
Min	0	0	0.0%	0
Const	1,725,904	1,290,374	-25.2%	-435,530
Manu	22,770	74,501	227.2%	51,731
TCPU	472,346	511,132	8.2%	38,786
Whole	70,794	68,777	-2.8%	-2,017
Retail	2,007,402	2,178,175	8.5%	170,773
FIRE	33,744	680,123	1915.5%	646,379
Service	824,064	812,308	-1.4%	-11,756
Total	5,185,784	5,615,390	8.3%	429,606

Table 4.9

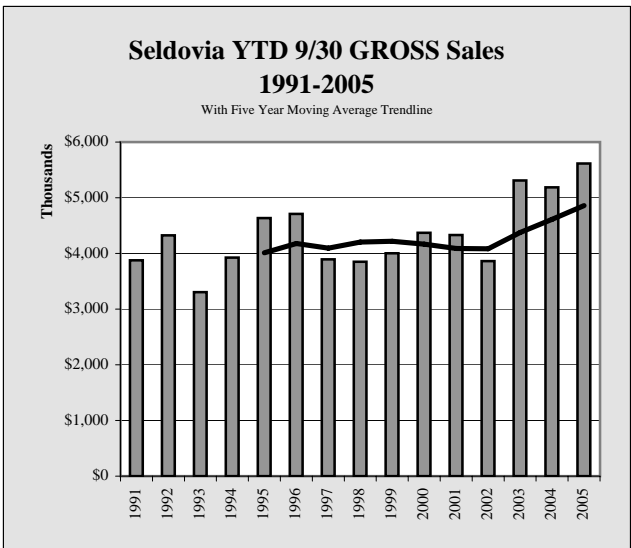

Chart 4.6

Seldovia Sales

Seldovia YTD 9/30 TAXABLE Sales by Industry - 1999-2005 - in \$								
	1999	2000	2001	2002	2003	2004	2005	Annual Change
AFF	3,084	2,771	3,616	3,551	2,970	3,140	0	-100.0%
Min	0	0	0	0	0	0	0	NA
Const	25,699	30,742	26,886	21,661	17,977	20,738	15,636	-24.6%
Manu	6,090	3,084	4,344	3,655	8,153	7,748	9,572	23.5%
TCPU	356,934	349,297	317,317	316,556	307,429	320,083	325,124	1.6%
Whole	103,017	3,633	2,971	945	1,111	298	207	-30.5%
Retail	1,479,499	1,760,300	1,800,860	1,712,524	1,729,410	1,704,537	1,724,750	1.2%
FIRE	54,364	21,746	24,013	20,857	21,813	25,071	40,377	61.1%
Service	601,340	656,883	567,106	584,694	613,392	606,838	588,548	-3.0%
Total	2,630,027	2,828,456	2,747,113	2,664,443	2,702,255	2,688,453	2,704,214	0.6%
Annual Change		7.5%	-2.9%	-3.0%	1.4%	-0.5%	0.6%	

Table 4.10

Seldovia YTD 9/30 TAXABLE Sales Ten Year Change by INDUSTRY - 1995 v. 2005 - in \$				
	10 Year Change			
	1995	2005	Percentage	Numerical
AFF	2,573	0	-100.0%	-2,573
Min	0	0	0.0%	0
Const	16,699	15,636	-6.4%	-1,063
Manu	55,800	9,572	-82.8%	-46,228
TCPU	326,514	325,124	-0.4%	-1,390
Whole	453,829	207	-100.0%	-453,622
Retail	1,203,222	1,724,750	43.3%	521,528
FIRE	95,619	40,377	-57.8%	-55,242
Service	737,064	588,548	-20.1%	-148,516
Total	2,891,320	2,704,214	0.0%	-187,106

Table 4.11

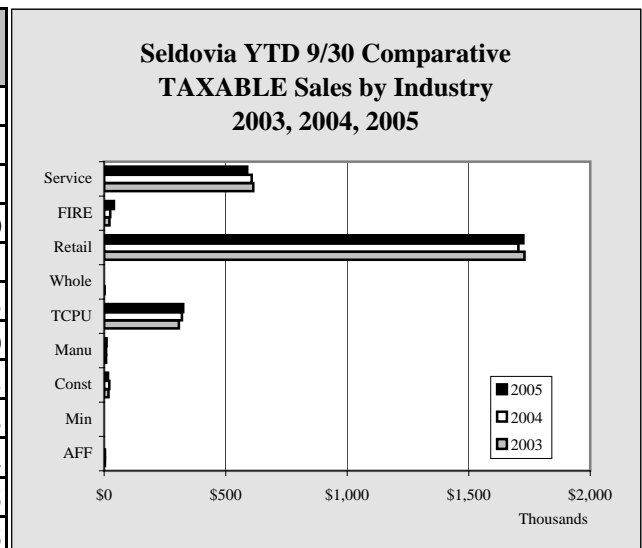

Chart 4.7

Seldovia YTD 9/30 TAXABLE Sales One Year Change by INDUSTRY - 2004 v. 2005 - in \$				
	1 Year Change			
	2004	2005	Percentage	Numerical
AFF	3,140	0	-100.0%	-3,140
Min	0	0	0.0%	0
Const	20,738	15,636	-24.6%	-5,102
Manu	7,748	9,572	23.5%	1,824
TCPU	320,083	325,124	1.6%	5,041
Whole	298	207	-30.5%	-91
Retail	1,704,537	1,724,750	1.2%	20,213
FIRE	25,071	40,377	61.1%	15,306
Service	606,838	588,548	-3.0%	-18,290
Total	2,688,453	2,704,214	0.6%	15,761

Table 4.12

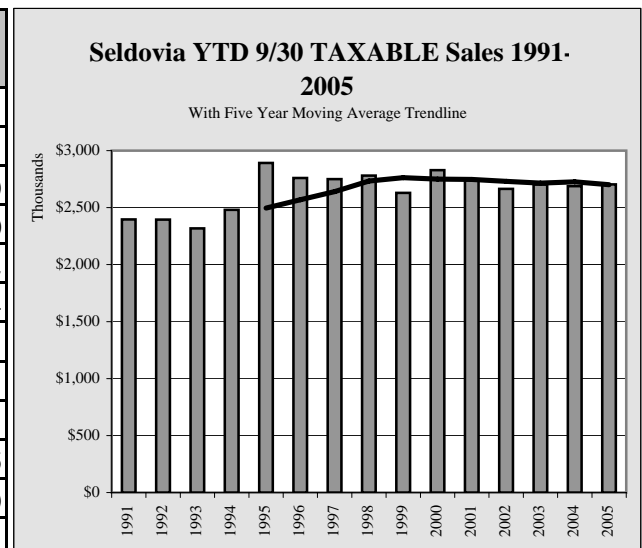

Chart 4.8

Seldovia Sales

Seldovia Annual GROSS Sales by Industry - 1998-2004 - in \$								
	1998	1999	2000	2001	2002	2003	2004	Annual Change
AFF	3,422	3,084	2,797	3,787	6,306	5,737	28,760	401.3%
Min	0	0	0	0	0	0	0	NA
Const	302,999	200,475	567,881	427,249	233,790	2,235,069	2,432,152	8.8%
Manu	53,202	142,303	22,483	40,983	41,694	44,136	24,563	-44.3%
TCPU	724,009	702,895	642,067	615,305	589,101	609,377	621,624	2.0%
Whole	886,557	466,249	74,511	58,140	40,755	143,974	105,348	-26.8%
Retail	1,698,659	2,359,533	2,969,768	2,710,711	2,527,071	2,565,299	2,640,802	2.9%
FIRE	134,421	111,959	62,750	509,244	443,797	590,854	1,450,792	145.5%
Service	920,470	858,272	925,068	884,052	935,363	1,065,108	1,025,790	-3.7%
Total	4,723,739	4,844,770	5,267,325	5,249,471	4,817,877	7,259,554	8,329,831	14.7%
Annual Change		2.6%	8.7%	-0.3%	-8.2%	50.7%	14.7%	

Table 4.13

Seldovia Annual GROSS Sales Ten Year Change by INDUSTRY - 1994 v. 2004 - in \$				
	10 Year Change			
	1994	2004	Percentage	Numerical
AFF	1,833	28,760	1469.0%	26,927
Min	48,415	0	-100.0%	-48,415
Const	317,413	2,432,152	666.2%	2,114,739
Manu	24,775	24,563	-0.9%	-212
TCPU	629,144	621,624	-1.2%	-7,520
Whole	1,434,711	105,348	-92.7%	-1,329,363
Retail	1,521,595	2,640,802	73.6%	1,119,207
FIRE	456,114	1,450,792	218.1%	994,678
Service	841,307	1,025,790	21.9%	184,483
Total	5,275,307	8,329,831	0.0%	3,054,524

Table 4.14

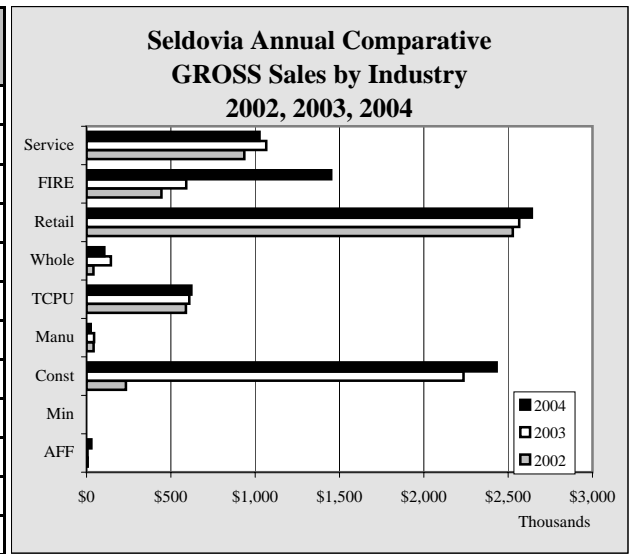

Chart 4.9

Seldovia Annual GROSS Sales One Year Change by INDUSTRY - 2003 v. 2004 - in \$				
	1 Year Change			
	2003	2004	Percentage	Numerical
AFF	5,737	28,760	401.3%	23,023
Min	0	0	0.0%	0
Const	2,235,069	2,432,152	8.8%	197,083
Manu	44,136	24,563	-44.3%	-19,573
TCPU	609,377	621,624	2.0%	12,247
Whole	143,974	105,348	-26.8%	-38,626
Retail	2,565,299	2,640,802	2.9%	75,503
FIRE	590,854	1,450,792	145.5%	859,938
Service	1,065,108	1,025,790	-3.7%	-39,318
Total	7,259,554	8,329,831	14.7%	1,070,277

Table 4.15

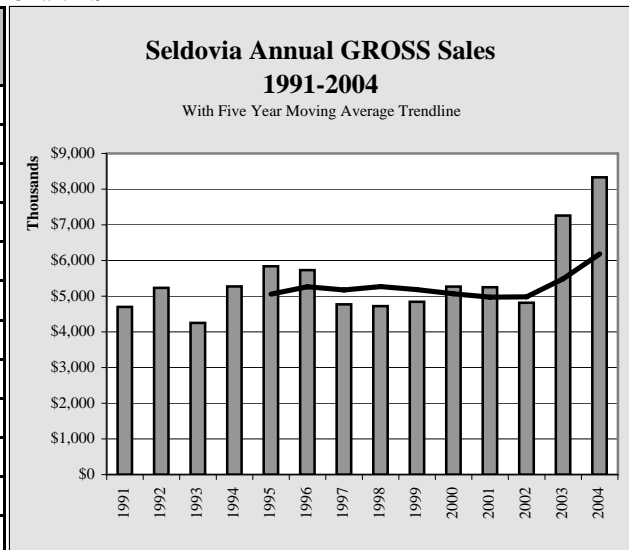

Chart 4.10

Seldovia Sales

Seldovia Annual TAXABLE Sales by Industry - 1998-2004 - in \$								
	1998	1999	2000	2001	2002	2003	2004	Annual Change
AFF	3,422	3,084	2,771	3,616	3,551	2,970	3,140	5.7%
Min	0	0	0	0	0	0	0	NA
Const	32,244	37,757	41,098	34,175	22,683	26,848	27,088	0.9%
Manu	16,711	7,035	4,892	4,818	6,509	9,098	9,146	0.5%
TCPU	438,292	473,005	455,499	410,584	427,667	450,291	411,317	-8.7%
Whole	510,369	106,422	4,692	4,069	945	1,649	426	-74.2%
Retail	1,577,816	1,877,036	2,165,560	2,226,879	2,118,927	2,155,556	2,167,989	0.6%
FIRE	83,118	65,347	28,771	31,657	24,937	29,796	47,940	60.9%
Service	736,321	659,563	714,840	643,481	667,170	700,736	719,266	2.6%
Total	3,398,293	3,229,249	3,418,123	3,359,279	3,272,389	3,376,944	3,386,312	0.3%
Annual Change		-5.0%	5.8%	-1.7%	-2.6%	3.2%	0.3%	

Table 4.16

Seldovia Annual TAXABLE Sales Ten Year Change by INDUSTRY - 1994 v. 2004 - in \$				
	10 Year Change			
	1994	2004	Percentage	Numerical
AFF	1,833	3,140	71.3%	1,307
Min	856	0	-100.0%	-856
Const	14,621	27,088	85.3%	12,467
Manu	13,541	9,146	-32.5%	-4,395
TCPU	415,239	411,317	-0.9%	-3,922
Whole	541,487	426	-99.9%	-541,061
Retail	1,374,783	2,167,989	57.7%	793,206
FIRE	84,223	47,940	-43.1%	-36,283
Service	670,602	719,266	7.3%	48,664
Total	3,117,185	3,386,312	0.0%	269,127

Table 4.17

Seldovia Annual TAXABLE Sales One Year Change by INDUSTRY - 2003 v. 2004 - in \$				
	1 Year Change			
	2003	2004	Percentage	Numerical
AFF	2,970	3,140	5.7%	170
Min	0	0	0.0%	0
Const	26,848	27,088	0.9%	240
Manu	9,098	9,146	0.5%	48
TCPU	450,291	411,317	-8.7%	-38,974
Whole	1,649	426	-74.2%	-1,223
Retail	2,155,556	2,167,989	0.6%	12,433
FIRE	29,796	47,940	60.9%	18,144
Service	700,736	719,266	2.6%	18,530
Total	3,376,944	3,386,312	0.3%	9,368

Table 4.18

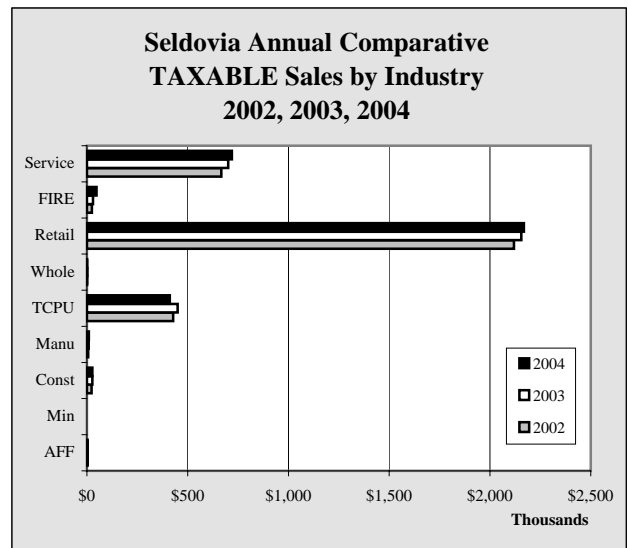

Chart 4.11

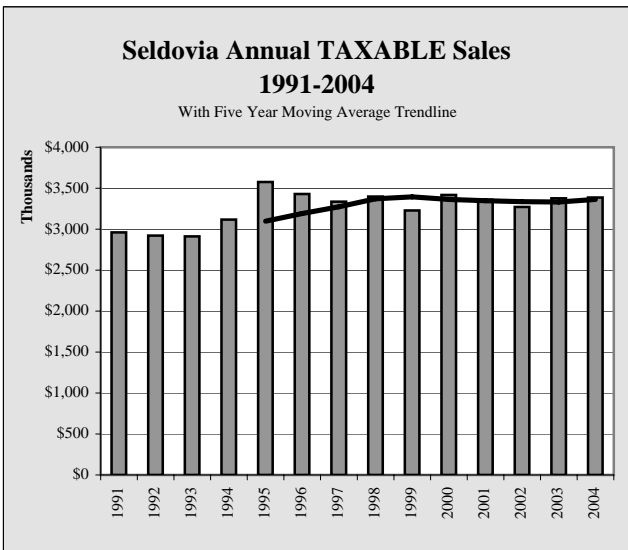

Chart 4.12

Seldovia Sales

Seldovia GROSS Sales by Industry by Quarter - 2001-2005 - in \$					
	1st Quarter	2nd Quarter	3rd Quarter	4th Quarter	Total
2001					
AFF	0	3,707	80	0	3,787
Const	30,023	287,028	65,667	44,531	427,249
Manu	2,989	14,430	22,581	983	40,983
TCPU	162,024	138,629	167,386	147,266	615,305
Whole	25,686	13,490	12,723	6,241	58,140
Retail	553,396	758,967	835,067	563,281	2,710,711
FIRE	23,824	17,006	458,280	10,134	509,244
Service	100,869	240,048	395,770	147,365	884,052
Total	898,811	1,473,305	1,957,554	919,801	5,249,471
2002					
AFF	0	6,306	0	0	6,306
Const	66,782	42,719	84,321	39,968	233,790
Manu	1,704	5,911	2,556	31,523	41,694
TCPU	163,245	136,379	137,154	152,323	589,101
Whole	3,760	7,040	22,402	7,553	40,755
Retail	485,479	690,215	825,256	526,121	2,527,071
FIRE	158,668	8,734	220,225	56,170	443,797
Service	132,074	257,751	402,260	143,278	935,363
Total	1,011,712	1,155,055	1,694,174	956,936	4,817,877
2003					
AFF	0	5,737	0	0	5,737
Min	0	0	0	0	0
Const	27,947	213,775	1,256,705	736,642	2,235,069
Manu	1,845	25,326	14,320	2,645	44,136
TCPU	147,749	135,580	137,236	188,812	609,377
Whole	9,201	17,477	71,441	45,855	143,974
Retail	544,320	711,358	768,860	540,761	2,565,299
FIRE	7,090	242,188	91,073	250,503	590,854
Service	108,853	278,014	494,150	184,091	1,065,108
Total	847,005	1,629,455	2,833,785	1,949,309	7,259,554
2004					
AFF	0	11,260	17,500	0	28,760
Min	0	0	0	0	0
Const	601,376	763,635	360,893	706,248	2,432,152
Manu	1,249	8,735	12,786	1,793	24,563
TCPU	151,748	152,078	168,520	149,278	621,624
Whole	14,150	26,237	30,407	34,554	105,348
Retail	522,637	722,686	762,079	633,400	2,640,802
FIRE	9,127	10,170	14,447	1,417,048	1,450,792
Service	104,760	276,869	442,435	201,726	1,025,790
Total	1,405,047	1,971,670	1,809,067	3,144,047	8,329,831
2005					
					Year to Date
AFF	0	0	0		0
Min	0	0	0		0
Const	433,991	412,463	443,920		1,290,374
Manu	1,331	36,891	36,279		74,501
TCPU	160,989	177,436	172,707		511,132
Whole	12,898	35,271	20,608		68,777
Retail	533,324	745,371	899,480		2,178,175
FIRE	16,009	424,120	239,994		680,123
Service	102,525	288,997	420,786		812,308
Total	1,261,067	2,120,549	2,233,774		5,615,390

Table 4.19

Seldovia Sales

Seldovia TAXABLE Sales by Industry by Quarter - 2001-2005 - in \$					
	1st Quarter	2nd Quarter	3rd Quarter	4th Quarter	Total
2001					
AFF	0	3,616	0	0	3,616
Const	7,595	9,498	9,793	7,289	34,175
Manu	1,054	1,243	2,047	474	4,818
TCPU	117,188	94,825	105,304	93,267	410,584
Whole	250	1,305	1,416	1,098	4,069
Retail	392,049	657,146	751,665	426,019	2,226,879
FIRE	6,389	7,434	10,190	7,644	31,657
Service	59,030	180,966	327,110	76,375	643,481
Total	583,555	956,033	1,207,525	612,166	3,359,279
2002					
AFF	0	3,551	0	0	3,551
Const	6,980	9,130	5,551	1,022	22,683
Manu	1,194	1,806	655	2,854	6,509
TCPU	115,021	95,299	106,236	111,111	427,667
Whole	159	135	651	0	945
Retail	367,416	590,349	754,759	406,403	2,118,927
FIRE	7,178	6,144	7,535	4,080	24,937
Service	75,676	192,416	316,602	82,476	667,170
Total	573,624	898,830	1,191,989	607,946	3,272,389
2003					
AFF	0	2,970	0	0	2,970
Min	0	0	0	0	0
Const	1,131	9,946	6,900	8,871	26,848
Manu	368	1,749	6,036	945	9,098
TCPU	103,692	96,701	107,036	142,862	450,291
Whole	150	321	640	538	1,649
Retail	415,056	620,851	693,503	426,146	2,155,556
FIRE	4,600	9,430	7,783	7,983	29,796
Service	73,973	220,998	318,421	87,344	700,736
Total	598,970	962,966	1,140,319	674,689	3,376,944
2004					
AFF	0	3,140	0	0	3,140
Min	0	0	0	0	0
Const	5,160	8,058	7,520	6,350	27,088
Manu	649	2,135	4,964	1,398	9,146
TCPU	96,989	105,084	118,010	91,234	411,317
Whole	30	137	131	128	426
Retail	392,241	613,360	698,936	463,452	2,167,989
FIRE	5,942	8,540	10,589	22,869	47,940
Service	65,715	199,135	341,988	112,428	719,266
Total	566,726	939,589	1,182,138	697,859	3,386,312
2005					
					Year to Date
AFF	0	0	0		0
Min	0	0	0		0
Const	4,155	5,615	5,866		15,636
Manu	831	2,819	5,922		9,572
TCPU	102,157	108,952	114,015		325,124
Whole	75	51	81		207
Retail	390,012	591,323	743,415		1,724,750
FIRE	11,204	10,740	18,433		40,377
Service	64,083	212,656	311,809		588,548
Total	572,517	932,156	1,199,541		2,704,214

Table 4.20

Seldovia Construction Permitting

Seldovia 3rd Quarter Permit Values by Type - 1998-2005 - in \$								
	1998	1999	2000	2001	2002	2003	2004	2005
Residential - New	0	55,000	19,000	10,000	308,000	150,000	0	0
Residential - Add/Alter	0	14,500	35,400	5,525	10,500	0	0	30,000
Commercial - New	0	12,000	0	0	0	1,685,000	0	0
Commercial - Add/Alter	0	6,000	3,500	0	0	0	0	500
TOTAL	0	87,500	57,900	15,525	318,500	1,835,000	0	30,500
Annual Change			-33.8%	-73.2%	1951.5%	476.1%	-100.0%	NA

Table 4.21

Seldovia 3rd Quarter Permit Volume by Type - 1998-2005								
	1998	1999	2000	2001	2002	2003	2004	2005
Residential - New	0	1	2	1	2	1	0	0
Residential - Add/Alter	0	4	3	4	2	0	0	1
Commercial - New	0	1	0	0	0	3	0	0
Commercial - Add/Alter	0	1	1	0	0	1	0	1
TOTAL	0	7	6	5	4	5	0	2
Annual Change		NA	-14.3%	-16.7%	-20.0%	25.0%	-100.0%	NA

Table 4.22

Seldovia YTD 9/30 Permit Values by Type - 1998-2005 - in \$								
	1998	1999	2000	2001	2002	2003	2004	2005
Residential - New	0	160,000	45,000	35,000	308,000	150,000	170,000	300,000
Residential - Add/Alter	0	31,000	55,700	5,525	28,500	31,000	6,200	49,000
Commercial - New	0	264,000	0	0	0	1,685,000	0	8,000
Commercial - Add/Alter	0	6,000	3,500	10,000	0	0	0	154,500
TOTAL	0	461,000	104,200	50,525	336,500	1,866,000	176,200	511,500
Annual Change			-77.4%	-51.5%	566.0%	454.5%	-90.6%	190.3%

Table 4.23

Seldovia YTD 9/30 Permit Volume by Type - 1998-2005								
	1998	1999	2000	2001	2002	2003	2004	2005
Residential - New	0	3	6	2	2	1	2	2
Residential - Add/Alter	0	8	5	4	5	3	2	3
Commercial - New	0	5	0	0	0	3	0	1
Commercial - Add/Alter	0	1	1	1	0	1	0	3
TOTAL	0	17	12	7	7	8	4	9
Annual Change		NA	-29.4%	-41.7%	0.0%	14.3%	-50.0%	125.0%

Table 4.24

Seldovia Construction Permitting

Seldovia Annual Permit Values by Type by Quarter - 1998-2005 - in \$					
	1st Quarter	2nd Quarter	3rd Quarter	4th Quarter	Total
1998					
Residential - New	0	0	0	0	0
Residential - Add/Alter	0	0	0	0	0
Commercial - New	0	0	0	0	0
Commercial - Add/Alter	0	0	0	0	0
TOTAL	0	0	0	0	0
1999					
Residential - New	0	105,000	55,000	0	160,000
Residential - Add/Alter	0	16,500	14,500	5,000	36,000
Commercial - New	8,000	244,000	12,000	0	264,000
Commercial - Add/Alter	0	0	6,000	13,000	19,000
TOTAL	8,000	365,500	87,500	18,000	479,000
2000					
Residential - New	18,000	8,000	19,000	0	45,000
Residential - Add/Alter	6,000	14,300	35,400	5,000	60,700
Commercial - New	0	0	0	0	0
Commercial - Add/Alter	0	0	3,500	0	3,500
TOTAL	24,000	22,300	57,900	5,000	109,200
2001					
Residential - New	0	25,000	10,000	0	35,000
Residential - Add/Alter	0	0	5,525	5,000	10,525
Commercial - New	0	0	0	0	0
Commercial - Add/Alter	10,000	0	0	10,000	20,000
TOTAL	10,000	25,000	15,525	15,000	65,525
2002					
Residential - New	0	0	308,000	0	308,000
Residential - Add/Alter	10,000	8,000	10,500	20,000	48,500
Commercial - New	0	0	0	0	0
Commercial - Add/Alter	0	0	0	0	0
TOTAL	10,000	8,000	318,500	20,000	356,500
2003					
Residential - New	0	0	150,000	26,000	176,000
Residential - Add/Alter	31,000	0	0	3,000	34,000
Commercial - New	0	0	1,685,000	7,500	1,692,500
Commercial - Add/Alter	0	0	0	0	0
TOTAL	31,000	0	1,835,000	36,500	1,902,500
2004					
Residential - New	20,000	150,000	0	0	170,000
Residential - Add/Alter	0	6,200	0	0	6,200
Commercial - New	0	0	0	0	0
Commercial - Add/Alter	0	0	0	0	0
TOTAL	20,000	156,200	0	0	176,200
2005					
					Year to Date
Residential - New	0	300,000	0		300,000
Residential - Add/Alter	15,000	4,000	30,000		49,000
Commercial - New	0	8,000	0		8,000
Commercial - Add/Alter	0	154,000	500		154,500
TOTAL	15,000	466,000	30,500		511,500

Table 4.25

Seldovia Construction Permitting

Seldovia Annual Permit Volume by Type by Quarter - 1998-2005					
	1st Quarter	2nd Quarter	3rd Quarter	4th Quarter	Total
1998					
Residential - New	0	0	0	0	0
Residential - Add/Alter	0	0	0	0	0
Commercial - New	0	0	0	0	0
Commercial - Add/Alter	0	0	0	0	0
TOTAL	0	0	0	0	0
1999					
Residential - New	0	2	1	0	3
Residential - Add/Alter	0	4	4	1	9
Commercial - New	1	3	1	0	5
Commercial - Add/Alter	0	0	1	2	3
TOTAL	1	9	7	3	20
2000					
Residential - New	2	2	2	0	6
Residential - Add/Alter	1	1	3	1	6
Commercial - New	0	0	0	0	0
Commercial - Add/Alter	0	0	1	0	1
TOTAL	3	3	6	1	13
2001					
Residential - New	0	1	1	0	2
Residential Add/Alter	0	0	4	1	5
Commercial - New	0	0	0	0	0
Commercial - Add/Alter	1	0	0	1	2
TOTAL	1	1	5	2	9
2002					
Residential - New	0	0	2	0	2
Residential Add/Alter	1	2	2	1	6
Commercial - New	0	0	0	0	0
Commercial - Add/Alter	0	0	0	0	0
TOTAL	1	2	4	1	8
2003					
Residential - New	0	0	1	2	3
Residential Add/Alter	3	0	0	1	4
Commercial - New	0	0	3	1	4
Commercial - Add/Alter	0	0	1	0	1
TOTAL	3	0	5	4	12
2004					
Residential - New	1	1	0	0	2
Residential Add/Alter	0	2	0	0	2
Commercial - New	0	0	0	0	0
Commercial - Add/Alter	0	0	0	0	0
TOTAL	1	3	0	0	4
2005					
					Year to Date
Residential - New	0	2	0		2
Residential Add/Alter	1	1	1		3
Commercial - New	0	1	0		1
Commercial - Add/Alter	0	2	1		3
TOTAL	1	6	2		9

Table 4.26

Seldovia Construction Permitting

This page intentionally left blank.

Seward Sales

Seward 3rd Quarter GROSS Sales by Industry - 1999-2005 - in \$								
	1999	2000	2001	2002	2003	2004	2005	Annual Change
AFF	128,618	333,788	181,243	99,235	233,386	248,373	1,058,218	326.1%
Min	93,274	117,514	129,526	133,354	49,094	89,202	127,576	43.0%
Const	2,774,781	3,770,097	7,349,494	2,223,341	9,666,381	6,884,443	7,203,901	4.6%
Manu	1,283,794	4,015,318	4,172,900	3,854,201	2,466,178	3,515,011	3,017,117	-14.2%
TCPU	4,506,935	5,766,771	4,717,487	5,193,908	5,201,510	3,570,845	4,082,503	14.3%
Whole	530,048	672,386	816,708	755,749	888,555	1,199,749	1,089,575	-9.2%
Retail	19,646,603	20,890,672	20,218,997	21,049,806	21,297,449	24,148,081	24,991,257	3.5%
FIRE	3,276,936	2,015,451	2,602,544	2,473,329	2,068,760	2,516,118	2,040,253	-18.9%
Service	18,268,656	19,678,082	22,684,750	20,938,726	19,836,458	21,754,783	22,836,310	5.0%
Govt	0	0	0	0	0	0	0	0.0%
Total	50,509,645	57,260,079	62,873,649	56,721,649	61,707,771	63,926,605	66,446,710	3.9%
Annual Change		13.4%	9.8%	-9.8%	8.8%	3.6%	3.9%	

Table 5.1

Seward 3rd Quarter GROSS Sales Ten Year Change by INDUSTRY - 1995 v. 2005 - in \$				
	10 Year Change			
	1995	2005	Percentage	Numerical
AFF	163,443	1,058,218	547.5%	894,775
Min	121,629	127,576	4.9%	5,947
Const	10,432,228	7,203,901	-30.9%	-3,228,327
Manu	2,104,692	3,017,117	43.4%	912,425
TCPU	3,721,279	4,082,503	9.7%	361,224
Whole	5,460,099	1,089,575	-80.0%	-4,370,524
Retail	12,486,292	24,991,257	100.1%	12,504,965
FIRE	1,326,791	2,040,253	53.8%	713,462
Service	13,888,645	22,836,310	64.4%	8,947,665
Total	49,705,098	66,446,710	33.7%	16,741,612

Table 5.2

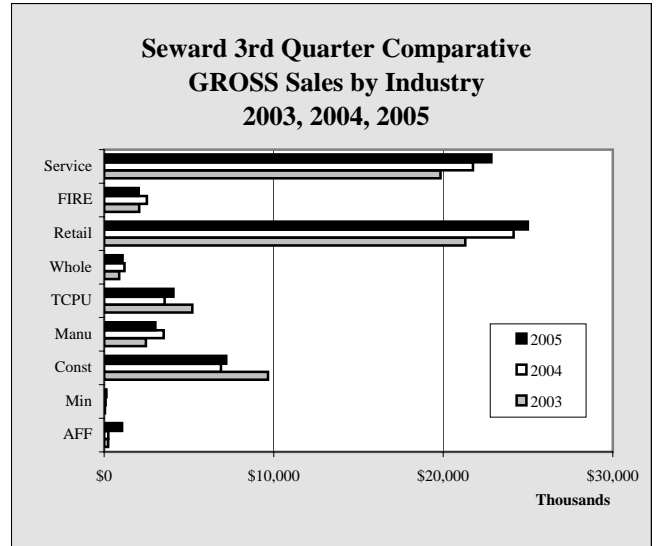

Chart 5.1

Seward 3rd Quarter GROSS Sales One Year Change by INDUSTRY - 2004 v. 2005 - in \$				
	1 Year Change			
	2004	2005	Percentage	Numerical
AFF	248,373	1,058,218	326.1%	809,845
Min	89,202	127,576	43.0%	38,374
Const	6,884,443	7,203,901	4.6%	319,458
Manu	3,515,011	3,017,117	-14.2%	-497,894
TCPU	3,570,845	4,082,503	14.3%	511,658
Whole	1,199,749	1,089,575	-9.2%	-110,174
Retail	24,148,081	24,991,257	3.5%	843,176
FIRE	2,516,118	2,040,253	-18.9%	-475,865
Service	21,754,783	22,836,310	5.0%	1,081,527
Total	63,926,605	66,446,710	3.9%	2,520,105

Table 5.3

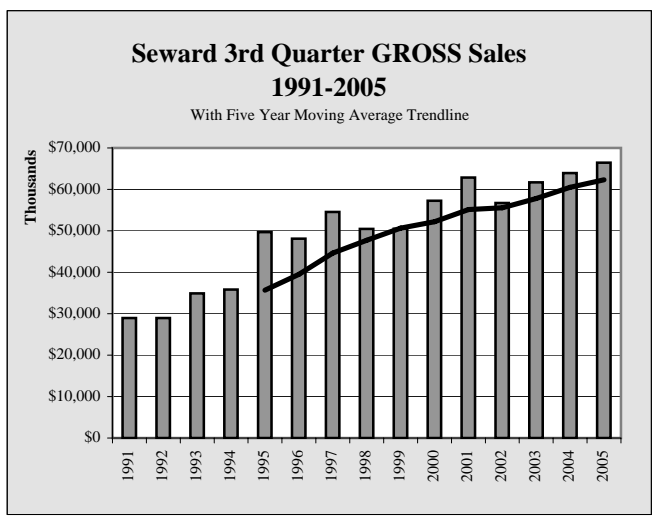

Chart 5.2

Seward Sales

Seward 3rd Quarter TAXABLE Sales by Industry - 1999-2005 - in \$								
	1999	2000	2001	2002	2003	2004	2005	Annual Change
AFF	42,899	134,031	81,902	39,602	116,949	129,744	143,691	10.7%
Min	0	0	0	0	1,701	0	0	NA
Const	199,459	169,538	146,352	155,433	174,588	187,781	169,742	-9.6%
Manu	144,972	152,889	402,392	451,494	183,847	163,756	140,134	-14.4%
TCPU	1,349,676	1,431,528	886,366	991,036	941,349	1,009,472	819,347	-18.8%
Whole	35,588	44,574	53,518	39,460	49,420	34,753	43,463	25.1%
Retail	14,825,711	15,521,607	16,023,761	16,466,497	16,898,663	18,197,996	18,416,545	1.2%
FIRE	484,514	439,963	481,279	593,326	530,822	563,136	621,847	10.4%
Service	14,706,249	15,009,343	15,515,763	15,601,212	15,805,043	16,790,786	18,020,742	7.3%
Govt	0	0	0	0	0	0	0	0.0%
Total	31,789,068	32,903,473	33,591,333	34,338,060	34,702,382	37,077,424	38,375,511	3.5%
Annual Change		3.5%	2.1%	2.2%	1.1%	6.8%	3.5%	

Table 5.4

Seward 3rd Quarter TAXABLE Sales Ten Year Change by INDUSTRY - 1995 v. 2005 - in \$				
	1995	2005	10 Year Change	
			Percentage	Numerical
AFF	55,168	143,691	160.5%	88,523
Min	1,117	0	-100.0%	-1,117
Const	172,355	169,742	-1.5%	-2,613
Manu	124,948	140,134	12.2%	15,186
TCPU	1,257,092	819,347	-34.8%	-437,745
Whole	274,894	43,463	-84.2%	-231,431
Retail	10,203,691	18,416,545	80.5%	8,212,854
FIRE	439,273	621,847	41.6%	182,574
Service	10,370,664	18,020,742	73.8%	7,650,078
Total	22,899,202	38,375,511	67.6%	15,476,309

Table 5.5

Seward 3rd Quarter TAXABLE Sales One Year Change by INDUSTRY - 2004 v. 2005 - in \$				
	2004	2005	1 Year Change	
			Percentage	Numerical
AFF	129,744	143,691	10.7%	13,947
Min	0	0	0.0%	0
Const	187,781	169,742	-9.6%	-18,039
Manu	163,756	140,134	-14.4%	-23,622
TCPU	1,009,472	819,347	-18.8%	-190,125
Whole	34,753	43,463	25.1%	8,710
Retail	18,197,996	18,416,545	1.2%	218,549
FIRE	563,136	621,847	10.4%	58,711
Service	16,790,786	18,020,742	7.3%	1,229,956
Total	37,077,424	38,375,511	3.5%	1,298,087

Table 5.6

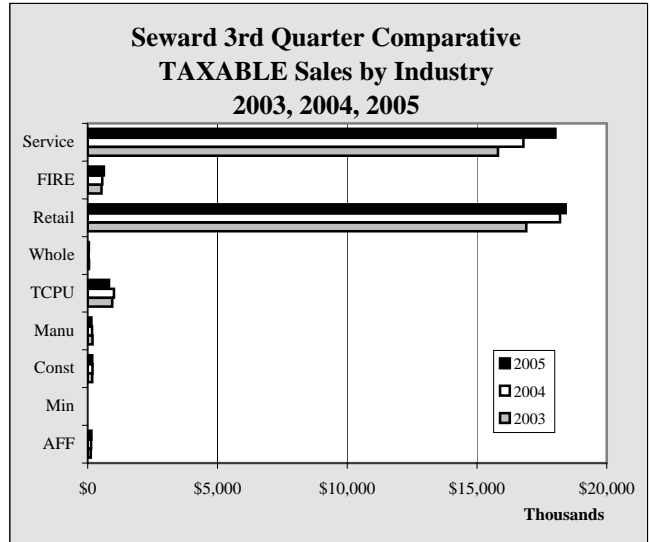

Chart 5.3

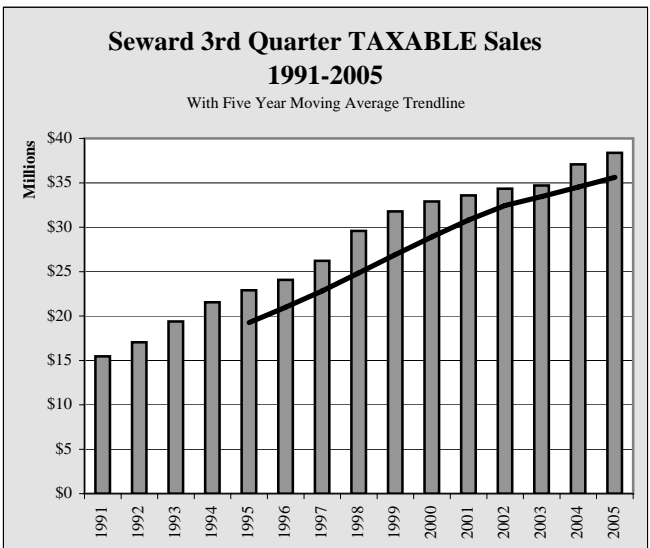

Chart 5.4

Seward Sales

Seward YTD 9/30 GROSS Sales by Industry - 1999-2005 - in \$							
	1999	2000	2001	2002	2003	2004	2005
AFF	382,635	648,958	379,591	273,353	449,653	573,949	1,377,159
Min	265,954	364,418	298,818	313,456	166,604	192,987	227,768
Const	10,277,599	8,857,368	19,258,333	7,627,405	23,184,791	14,678,562	32,375,270
Manu	3,593,122	6,917,478	10,184,964	9,089,869	7,720,069	6,329,712	6,230,772
TCPU	9,771,380	11,840,722	10,564,365	10,852,000	10,600,092	9,396,600	10,062,758
Whole	2,667,884	1,951,458	1,849,491	1,814,539	1,956,390	2,654,637	2,713,211
Retail	40,395,879	43,391,739	42,329,811	44,292,082	44,073,171	50,716,433	53,778,500
FIRE	7,635,391	6,277,704	4,839,202	6,609,590	5,569,340	5,586,227	5,104,727
Service	34,918,013	34,112,068	38,152,624	39,188,744	35,906,998	37,733,587	39,458,375
Govt	0	0	0	0	0	0	0
Total	109,907,857	114,361,913	127,857,199	120,061,038	129,627,108	127,862,694	151,328,540
Annual Change		4.1%	11.8%	-6.1%	8.0%	-1.4%	18.4%

Table 5.7

Seward YTD 9/30 GROSS Sales Ten Year Change by INDUSTRY - 1995 v. 2005 - in \$				
	10 Year Change			
	1995	2005	Percentage	Numerical
AFF	477,978	1,377,159	188.1%	899,181
Min	347,618	227,768	-34.5%	-119,850
Const	15,766,762	32,375,270	105.3%	16,608,508
Manu	4,804,487	6,230,772	29.7%	1,426,285
TCPU	9,049,312	10,062,758	11.2%	1,013,446
Whole	11,394,530	2,713,211	-76.2%	-8,681,319
Retail	27,866,327	53,778,500	93.0%	25,912,173
FIRE	3,506,300	5,104,727	45.6%	1,598,427
Service	25,540,734	39,458,375	54.5%	13,917,641
Govt	0	0	0.0%	0
Total	98,754,048	151,328,540	53.2%	52,574,492

Table 5.8

Seward YTD 9/30 GROSS Sales One Year Change by INDUSTRY - 2004 v. 2005 - in \$				
	1 Year Change			
	2004	2005	Percentage	Numerical
AFF	573,949	1,377,159	139.9%	803,210
Min	192,987	227,768	0.0%	34,781
Const	14,678,562	32,375,270	120.6%	17,696,708
Manu	6,329,712	6,230,772	-1.6%	-98,940
TCPU	9,396,600	10,062,758	7.1%	666,158
Whole	2,654,637	2,713,211	2.2%	58,574
Retail	50,716,433	53,778,500	6.0%	3,062,067
FIRE	5,586,227	5,104,727	-8.6%	-481,500
Service	37,733,587	39,458,375	4.6%	1,724,788
Govt	0	0	0.0%	0
Total	127,862,694	151,328,540	18.4%	23,465,846

Table 5.9

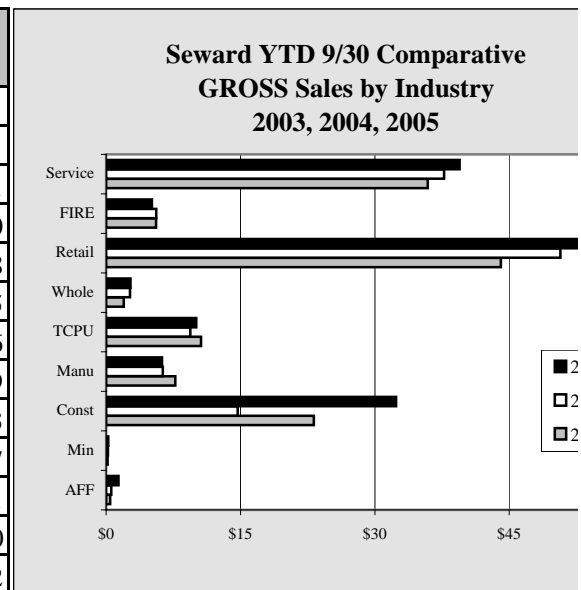

Chart 5.5

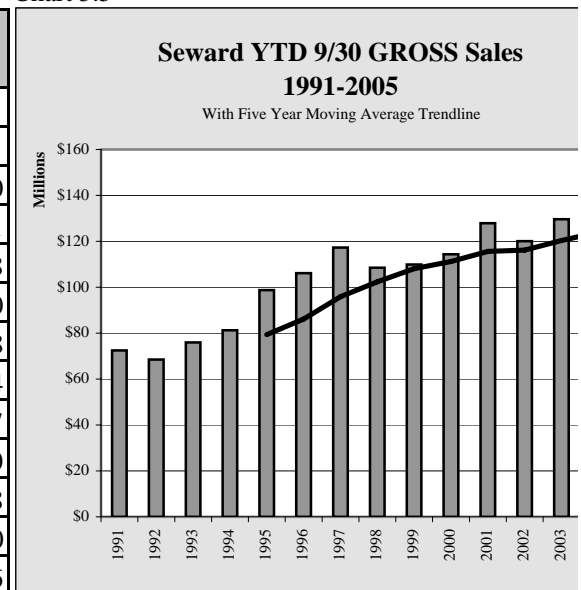
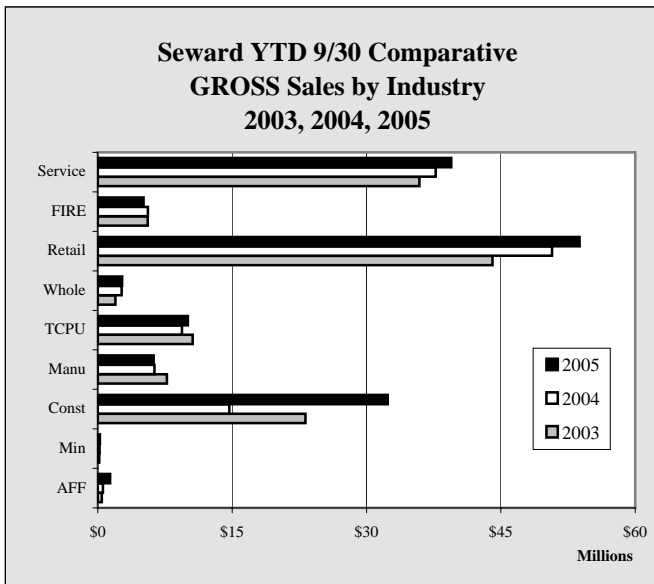

Chart 5.6

Seward Sales

Annual Change
139.9%
NA
120.6%
-1.6%
7.1%
2.2%
6.0%
-8.6%
4.6%
NA
18.4%



Seward Sales

Seward YTD 9/30 TAXABLE Sales by Industry - 1999-2005 - in \$							
	1999	2000	2001	2002	2003	2004	2005
AFF	114,343	225,079	155,662	104,078	199,127	219,537	239,972
Min	1,444	500	0	0	3,455	0	0
Const	533,853	517,365	436,636	424,998	491,519	553,993	545,444
Manu	460,274	472,654	839,471	866,516	485,838	458,016	362,496
TCPU	3,008,624	3,285,602	2,334,896	2,332,637	2,336,344	2,349,864	2,135,084
Whole	104,788	119,117	124,631	90,227	104,775	93,195	92,508
Retail	29,755,170	31,483,263	32,216,388	33,034,211	33,965,253	35,989,484	38,426,481
FIRE	1,310,450	1,188,935	1,278,812	1,436,652	1,276,643	1,253,612	1,377,719
Service	25,625,986	26,146,216	26,831,594	27,276,259	27,196,013	28,651,532	30,616,990
Govt	0	0	0	0	0	0	0
Total	60,914,932	63,438,731	64,218,090	65,565,578	66,058,967	69,569,233	73,796,694
Annual Change		4.1%	1.2%	2.1%	0.8%	5.3%	6.1%

Table 5.10

Seward YTD 9/30 TAXABLE Sales Ten Year Change by INDUSTRY - 1995 v. 2005 - in \$				
	10 Year Change			
	1995	2005	Percentage	Numerical
AFF	161,218	239,972	48.8%	78,754
Min	1,704	0	-100.0%	-1,704
Const	453,393	545,444	20.3%	92,051
Manu	386,856	362,496	-6.3%	-24,360
TCPU	2,802,092	2,135,084	-23.8%	-667,008
Whole	759,555	92,508	-87.8%	-667,047
Retail	21,897,904	38,426,481	75.5%	16,528,577
FIRE	1,248,605	1,377,719	10.3%	129,114
Service	19,583,790	30,616,990	56.3%	11,033,200
Govt	0	0	0.0%	0
Total	47,295,117	73,796,694	56.0%	26,501,577

Table 5.11

Seward YTD 9/30 TAXABLE Sales One Year Change by INDUSTRY - 2004 v. 2005 - in \$				
	1 Year Change			
	2004	2005	Percentage	Numerical
AFF	219,537	239,972	9.3%	20,435
Min	0	0	0.0%	0
Const	553,993	545,444	-1.5%	-8,549
Manu	458,016	362,496	-20.9%	-95,520
TCPU	2,349,864	2,135,084	-9.1%	-214,780
Whole	93,195	92,508	-0.7%	-687
Retail	35,989,484	38,426,481	6.8%	2,436,997
FIRE	1,253,612	1,377,719	9.9%	124,107
Service	28,651,532	30,616,990	6.9%	1,965,458
Govt	0	0	0.0%	0
Total	69,569,233	73,796,694	6.1%	4,227,461

Table 5.12

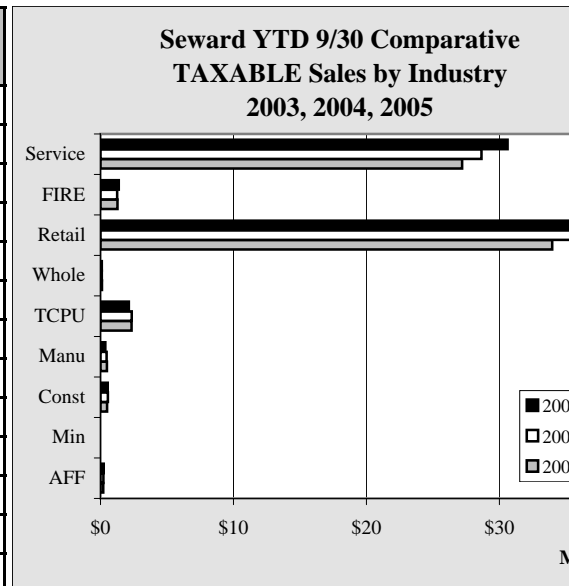

Chart 5.7

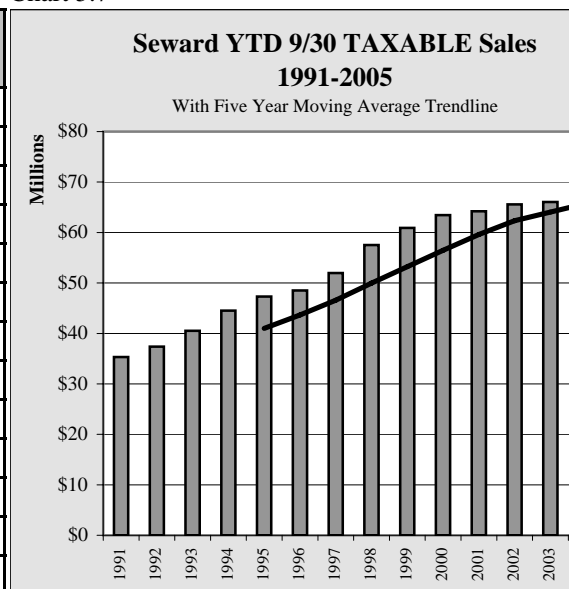
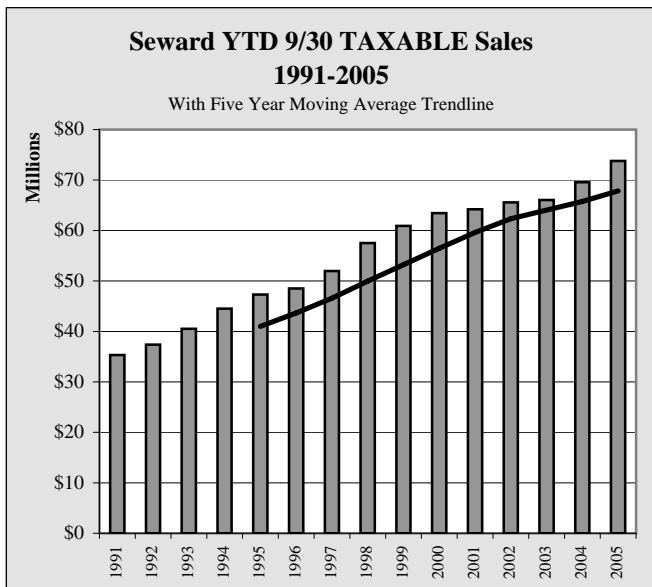
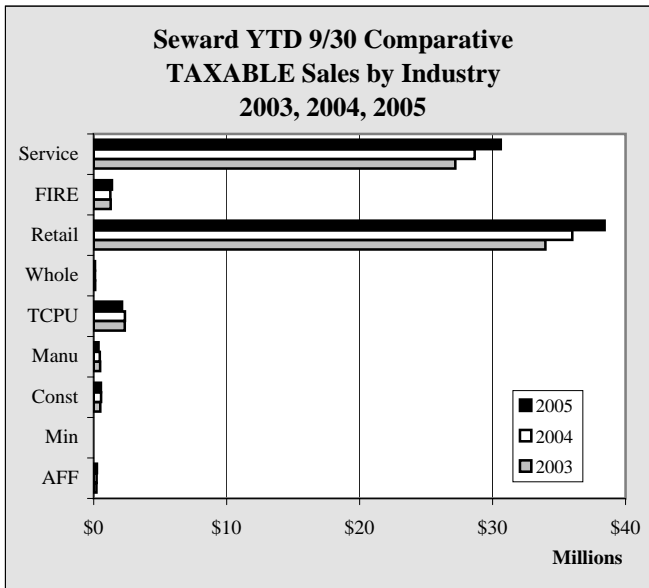

Chart 5.8

Seward Sales

Annual Change
9.3%
NA
-1.5%
-20.9%
-9.1%
-0.7%
6.8%
9.9%
6.9%
NA
6.1%



Seward Sales

Seward Annual GROSS Sales by Industry - 1998-2004 - in \$

	1998	1999	2000	2001	2002	2003	2004	Annual Change
AFF	472,717	414,123	689,481	437,640	298,046	489,097	651,718	33.2%
Min	229,681	332,546	405,115	330,859	377,441	189,755	228,403	20.4%
Const	19,183,104	12,588,992	16,255,816	21,082,426	11,084,304	28,881,212	31,492,128	9.0%
Manu	4,266,551	4,895,971	9,541,307	12,023,577	11,540,635	10,446,881	7,214,583	-30.9%
TCPU	13,656,791	12,011,182	14,705,875	12,840,952	13,026,323	12,969,855	11,702,893	-9.8%
Whole	7,270,151	3,064,525	2,339,175	2,231,731	2,208,659	2,600,579	3,953,585	52.0%
Retail	44,656,247	48,356,132	51,460,505	50,408,318	52,600,754	53,594,945	60,076,596	12.1%
FIRE	8,498,546	9,458,188	8,394,110	6,333,381	7,595,826	7,557,129	7,207,271	-4.6%
Service	34,272,460	39,033,862	38,360,895	42,671,669	43,635,138	40,232,069	43,696,493	8.6%
Govt	0	0	0	0	0	0	0	0.0%
Total	132,506,248	130,155,521	142,152,279	148,360,553	142,367,126	156,961,522	166,223,670	5.9%
Annual Change		-1.8%	9.2%	4.4%	-4.0%	10.3%	5.9%	

Table 5.13

**Seward Annual GROSS Sales Ten Year Change
by INDUSTRY - 1994 v. 2004 - in \$**

	1994	2004	10 Year Change	
			Percentage	Numerical
AFF	700,784	651,718	-7.0%	-49,066
Min	520,955	228,403	-56.2%	-292,552
Const	4,896,660	31,492,128	543.1%	26,595,468
Manu	7,417,987	7,214,583	-2.7%	-203,404
TCPU	12,005,099	11,702,893	-2.5%	-302,206
Whole	10,931,263	3,953,585	-63.8%	-6,977,678
Retail	33,848,338	60,076,596	77.5%	26,228,258
FIRE	5,193,579	7,207,271	38.8%	2,013,692
Service	24,360,349	43,696,493	79.4%	19,336,144
Govt	0	0	0.0%	0
Total	99,875,014	166,223,670	0.0%	66,348,656

Table 5.14

**Seward Annual GROSS Sales One Year Change
by INDUSTRY - 2003 v. 2004 - in \$**

	2003	2004	1 Year Change	
			Percentage	Numerical
AFF	489,097	651,718	33.2%	162,621
Min	189,755	228,403	0.0%	38,648
Const	28,881,212	31,492,128	9.0%	2,610,916
Manu	10,446,881	7,214,583	-30.9%	-3,232,298
TCPU	12,969,855	11,702,893	-9.8%	-1,266,962
Whole	2,600,579	3,953,585	52.0%	1,353,006
Retail	53,594,945	60,076,596	12.1%	6,481,651
FIRE	7,557,129	7,207,271	-4.6%	-349,858
Service	40,232,069	43,696,493	8.6%	3,464,424
Govt	0	0	0.0%	0
Total	156,961,522	166,223,670	5.9%	9,262,148

Table 5.15

**Seward Annual Comparative
GROSS Sales by Industry
2002, 2003, 2004**

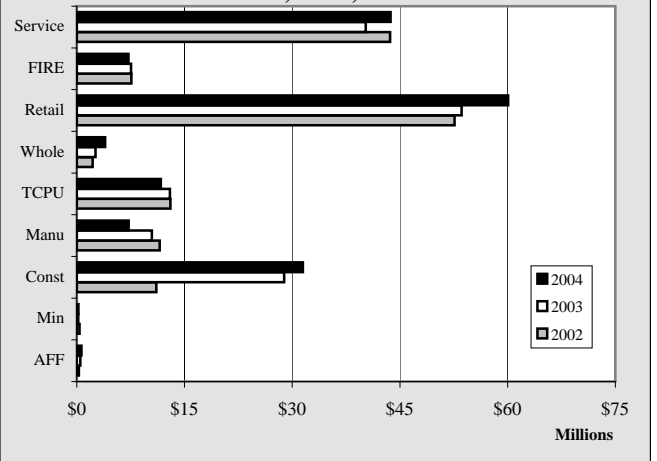

Chart 5.9

**Seward Annual GROSS Sales
1991-2004
With Five Year Moving Average Trendline**

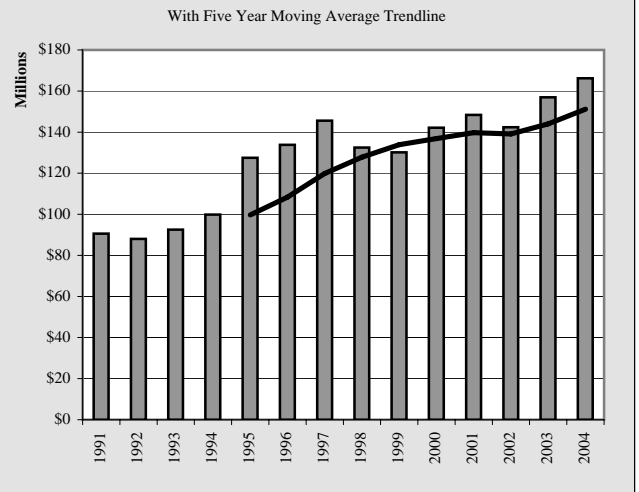

Chart 5.10

Seward Sales

Seward Annual TAXABLE Sales by Industry - 1998-2004 - in \$								
	1998	1999	2000	2001	2002	2003	2004	Annual Change
AFF	190,979	126,681	240,141	170,624	114,521	217,323	227,337	4.6%
Min	221	1,444	500	0	0	3,455	0	NA
Const	709,318	718,945	671,326	567,626	565,290	683,590	739,180	8.1%
Manu	505,430	585,005	639,366	962,382	988,659	629,648	605,028	-3.9%
TCPU	3,826,559	3,801,591	3,991,338	2,936,725	2,916,215	2,921,669	2,853,456	-2.3%
Whole	382,361	128,287	141,551	135,396	107,027	119,020	107,918	-9.3%
Retail	33,478,522	35,539,902	37,600,377	38,191,615	39,040,960	40,272,089	42,443,807	5.4%
FIRE	1,604,043	1,662,085	1,583,364	1,665,703	1,780,596	1,593,083	1,583,071	-0.6%
Service	26,580,831	28,908,259	29,115,463	29,595,520	30,085,428	29,908,392	31,395,862	5.0%
Govt	0	0	0	0	0	0	0	0.0%
Total	67,278,264	71,472,199	73,983,426	74,225,591	75,598,696	76,348,269	79,955,659	4.7%
Annual Change		6.2%	3.5%	0.3%	1.8%	1.0%	4.7%	

Table 5.16

Seward Annual TAXABLE Sales Ten Year Change by INDUSTRY - 1994 v. 2004 - in \$				
			10 Year Change	
	1994	2004	Percentage	Numerical
AFF	195,909	227,337	16.0%	31,428
Min	0	0	0.0%	0
Const	518,056	739,180	42.7%	221,124
Manu	502,127	605,028	20.5%	102,901
TCPU	3,358,628	2,853,456	-15.0%	-505,172
Whole	918,510	107,918	-88.3%	-810,592
Retail	25,931,542	42,443,807	63.7%	16,512,265
FIRE	1,704,130	1,583,071	-7.1%	-121,059
Service	20,130,275	31,395,862	56.0%	11,265,587
Govt	0	0	0.0%	0
Total	53,259,177	79,955,659	0.0%	26,696,482

Table 5.17

Seward Annual TAXABLE Sales One Year Change by INDUSTRY - 2003 v. 2004 - in \$				
			1 Year Change	
	2003	2004	Percentage	Numerical
AFF	217,323	227,337	4.6%	10,014
Min	3,455	0	0.0%	-3,455
Const	683,590	739,180	8.1%	55,590
Manu	629,648	605,028	-3.9%	-24,620
TCPU	2,921,669	2,853,456	-2.3%	-68,213
Whole	119,020	107,918	-9.3%	-11,102
Retail	40,272,089	42,443,807	5.4%	2,171,718
FIRE	1,593,083	1,583,071	-0.6%	-10,012
Service	29,908,392	31,395,862	5.0%	1,487,470
Govt	0	0	0.0%	0
Total	76,348,269	79,955,659	4.7%	3,607,390

Table 5.18

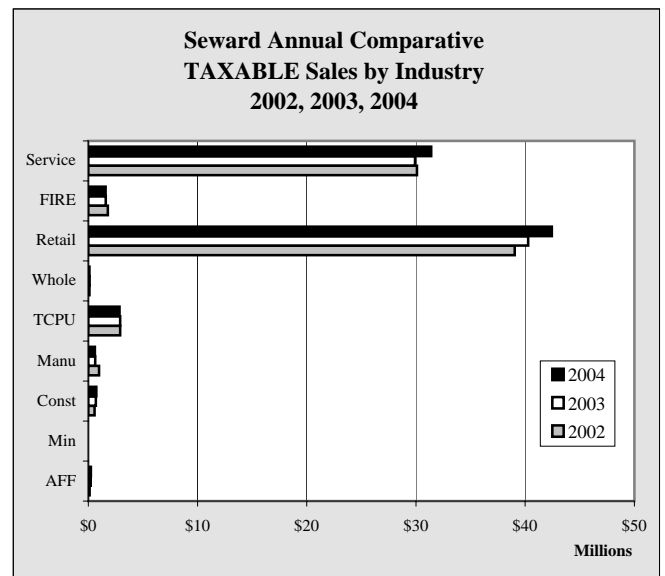

Chart 5.11

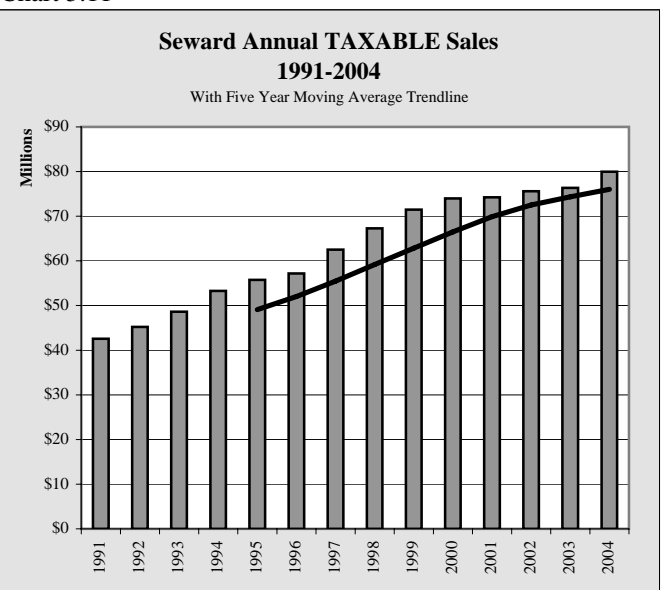

Chart 5.12

Seward Sales

Seward GROSS Sales by Industry by Quarter - 2002-2005 - in \$					
	1st Quarter	2nd Quarter	3rd Quarter	4th Quarter	Total
2002					
AFF	20,810	153,308	99,235	24,693	298,046
Min	48,952	131,150	133,354	63,985	377,441
Const	3,040,364	2,363,700	2,223,341	3,456,899	11,084,304
Manu	1,974,606	3,261,062	3,854,201	2,450,766	11,540,635
TCPU	2,253,103	3,404,989	5,193,908	2,174,323	13,026,323
Whole	386,897	671,893	755,749	394,120	2,208,659
Retail	7,932,221	15,310,055	21,049,806	8,308,672	52,600,754
FIRE	1,790,625	2,345,636	2,473,329	986,236	7,595,826
Service	5,506,435	12,743,583	20,938,726	4,446,394	43,635,138
Govt	0	0	0	0	0
Total	22,954,013	40,385,376	56,721,649	22,306,088	142,367,126
2003					
AFF	35,450	180,817	233,386	39,444	489,097
Min	67,921	49,589	49,094	23,151	189,755
Const	3,401,454	10,116,956	9,666,381	5,696,421	28,881,212
Manu	1,468,277	3,785,614	2,466,178	2,726,812	10,446,881
TCPU	2,084,901	3,313,681	5,201,510	2,369,763	12,969,855
Whole	385,079	682,756	888,555	644,189	2,600,579
Retail	7,798,633	14,977,089	21,297,449	9,521,774	53,594,945
FIRE	1,394,159	2,106,421	2,068,760	1,987,789	7,557,129
Service	4,299,310	11,771,230	19,836,458	4,325,071	40,232,069
Govt	0	0	0	0	0
Total	20,935,184	46,984,153	61,707,771	27,334,414	156,961,522
2004					
AFF	54,549	271,027	248,373	77,769	651,718
Min	24,996	78,789	89,202	35,416	228,403
Const	3,306,762	4,487,357	6,884,443	16,813,566	31,492,128
Manu	892,586	1,922,115	3,515,011	884,871	7,214,583
TCPU	2,592,442	3,233,313	3,570,845	2,306,293	11,702,893
Whole	544,648	910,240	1,199,749	1,298,948	3,953,585
Retail	8,625,281	17,943,071	24,148,081	9,360,163	60,076,596
FIRE	1,407,043	1,663,066	2,516,118	1,621,044	7,207,271
Service	3,726,982	12,251,822	21,754,783	5,962,906	43,696,493
Govt	0	0	0	0	0
Total	21,175,289	42,760,800	63,926,605	38,360,976	166,223,670
2005					
					Year to Date
AFF	30,789	288,152	1,058,218		1,377,159
Min	32,647	67,545	127,576		227,768
Const	8,105,477	17,065,892	7,203,901		32,375,270
Manu	954,605	2,259,050	3,017,117		6,230,772
TCPU	2,745,656	3,234,599	4,082,503		10,062,758
Whole	520,743	1,102,893	1,089,575		2,713,211
Retail	9,100,347	19,686,896	24,991,257		53,778,500
FIRE	1,102,999	1,961,475	2,040,253		5,104,727
Service	3,866,022	12,756,043	22,836,310		39,458,375
Govt	0	0	0		0
Total	26,459,285	58,422,545	66,446,710		151,328,540

Table 5.19

Seward Sales

Seward TAXABLE Sales by Industry by Quarter - 2002-2005 - in \$					
	1st Quarter	2nd Quarter	3rd Quarter	4th Quarter	Total
2002					
AFF	6,729	57,747	39,602	10,443	114,521
Min	0	0	0	0	0
Const	128,807	140,758	155,433	140,292	565,290
Manu	115,801	299,221	451,494	122,143	988,659
TCPU	560,857	780,744	991,036	583,578	2,916,215
Whole	12,026	38,741	39,460	16,800	107,027
Retail	5,387,940	11,179,774	16,466,497	6,006,749	39,040,960
FIRE	354,630	488,696	593,326	343,944	1,780,596
Service	2,484,254	9,190,793	15,601,212	2,809,169	30,085,428
Govt	0	0	0	0	0
Total	9,051,044	22,176,474	34,338,060	10,033,118	75,598,696
2003					
AFF	11,673	70,505	116,949	18,196	217,323
Min	0	1,754	1,701	0	3,455
Const	126,874	190,057	174,588	192,071	683,590
Manu	144,853	157,138	183,847	143,810	629,648
TCPU	588,465	806,530	941,349	585,325	2,921,669
Whole	15,297	40,058	49,420	14,245	119,020
Retail	5,600,762	11,465,828	16,898,663	6,306,836	40,272,089
FIRE	330,069	415,752	530,822	316,440	1,593,083
Service	2,466,511	8,924,459	15,805,043	2,712,379	29,908,392
Govt	0	0	0	0	0
Total	9,284,504	22,072,081	34,702,382	10,289,302	76,348,269
2004					
AFF	11,923	77,870	129,744	7,800	227,337
Min	0	0	0	0	0
Const	167,430	198,782	187,781	185,187	739,180
Manu	131,626	162,634	163,756	147,012	605,028
TCPU	581,778	758,614	1,009,472	503,592	2,853,456
Whole	23,473	34,969	34,753	14,723	107,918
Retail	5,834,809	11,956,679	18,197,996	6,454,323	42,443,807
FIRE	295,698	394,778	563,136	329,459	1,583,071
Service	2,448,027	9,412,719	16,790,786	2,744,330	31,395,862
Govt	0	0	0	0	0
Total	9,494,764	22,997,045	37,077,424	10,386,426	79,955,659
2005					
					Year to Date
AFF	8,489	87,792	143,691		239,972
Min	0	0	0		0
Const	160,163	215,539	169,742		545,444
Manu	87,178	135,184	140,134		362,496
TCPU	588,048	727,689	819,347		2,135,084
Whole	14,534	34,511	43,463		92,508
Retail	6,380,641	13,629,295	18,416,545		38,426,481
FIRE	284,939	470,933	621,847		1,377,719
Service	2,567,408	10,028,840	18,020,742		30,616,990
Govt	0	0	0		0
Total	10,091,400	25,329,783	38,375,511		73,796,694

Table 5.20

Seward Construction Permitting

Seward 3rd Quarter Permit VALUES by Type - 1999-2005 - in \$								
	1999	2000	2001	2002	2003	2004	2005	Annual Change
Residential New	509,400	263,000	150,000	205,000	744,500	1,257,000	455,000	-63.8%
Residential Alter/Add	71,900	39,000	136,014	27,555	87,000	299,500	6,761	-97.7%
Commercial New	903,275	330,000	331,028	750,000	900,000	518,800	81,400	-84.3%
Commercial Alter/Add	131,174	79,465	25,000	325,021	101,400	191,000	110,500	-42.1%
Total	1,615,749	711,465	642,042	1,307,576	1,832,900	2,266,300	653,661	-71.2%
Annual Change		-56.0%	-9.8%	103.7%	40.2%	23.6%	-71.2%	

Table 5.21

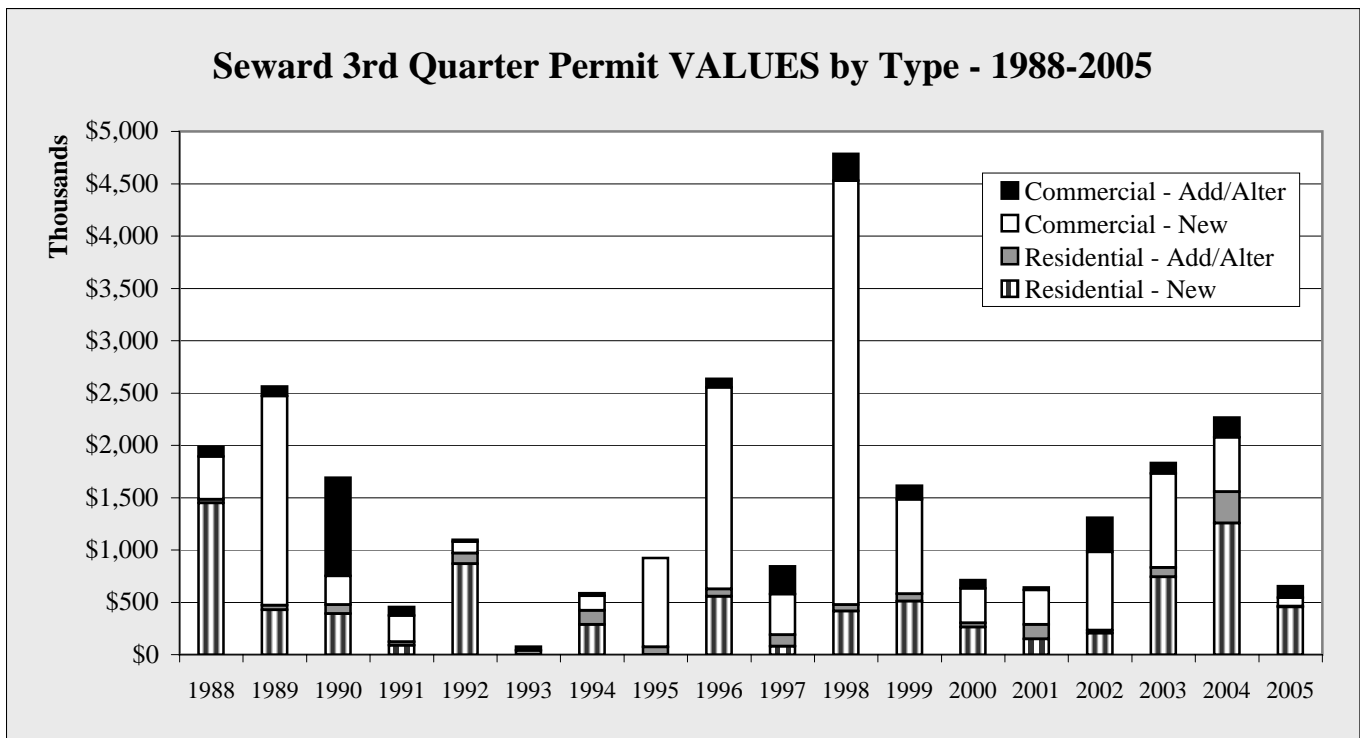

Chart 5.13

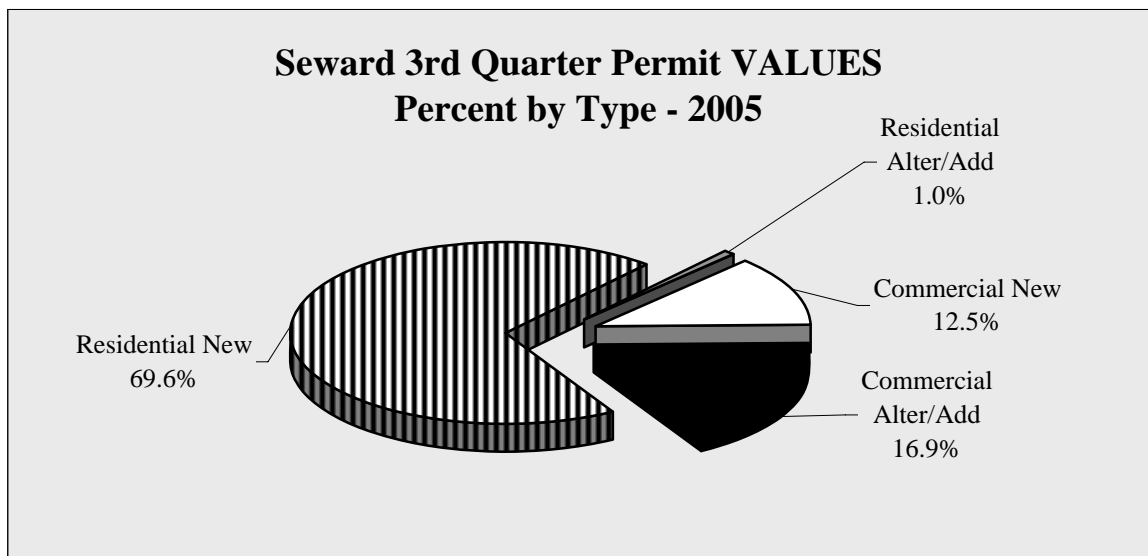

Chart 5.14

Seward Construction Permitting

Seward 3rd Quarter Permit VOLUME by Type - 1999-2005								
	1999	2000	2001	2002	2003	2004	2005	Annual Change
Residential New	4	2	1	2	5	8	3	-62.5%
Residential Alter/Add	5	7	9	3	5	5	5	0.0%
Commercial New	5	3	3	1	1	2	1	-50.0%
Commercial Alter/Add	9	5	1	8	4	4	4	0.0%
Total	23	17	14	14	15	19	13	-31.6%
Annual Change		-26.1%	-17.6%	0.0%	7.1%	26.7%	-31.6%	

Table 5.22

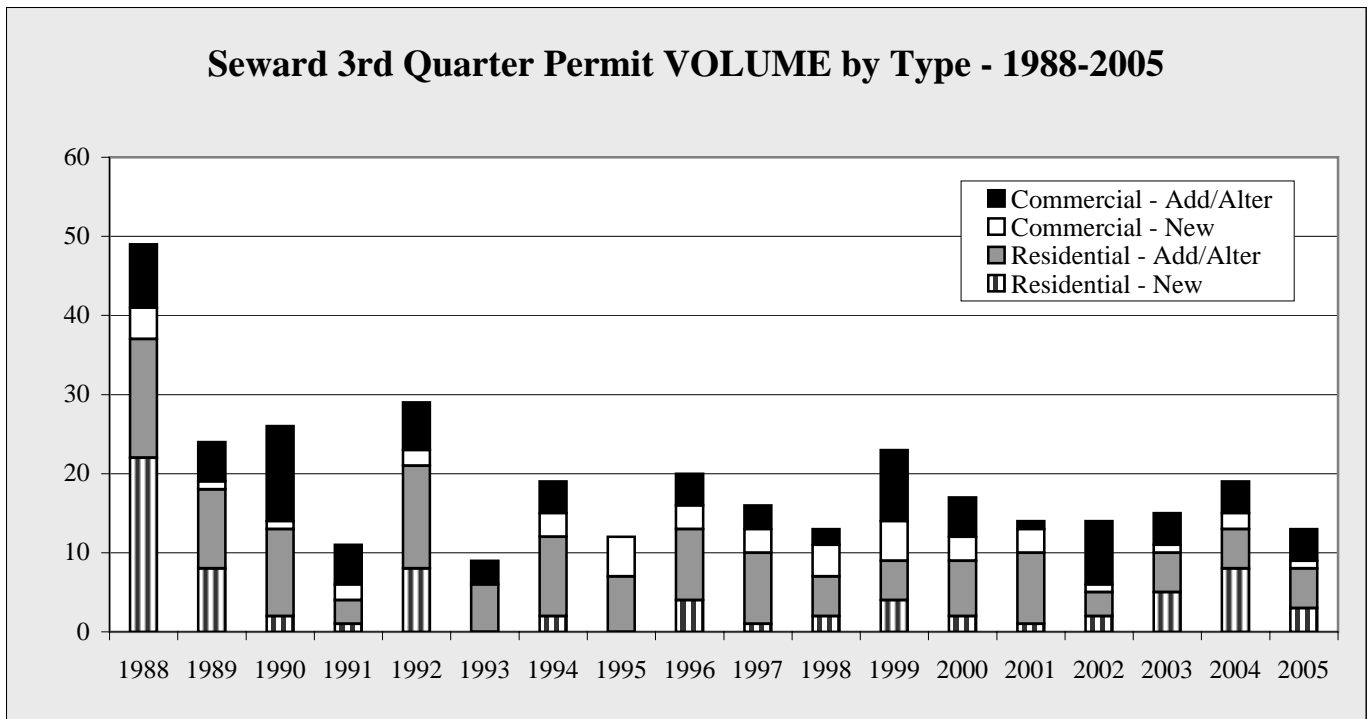

Chart 5.15

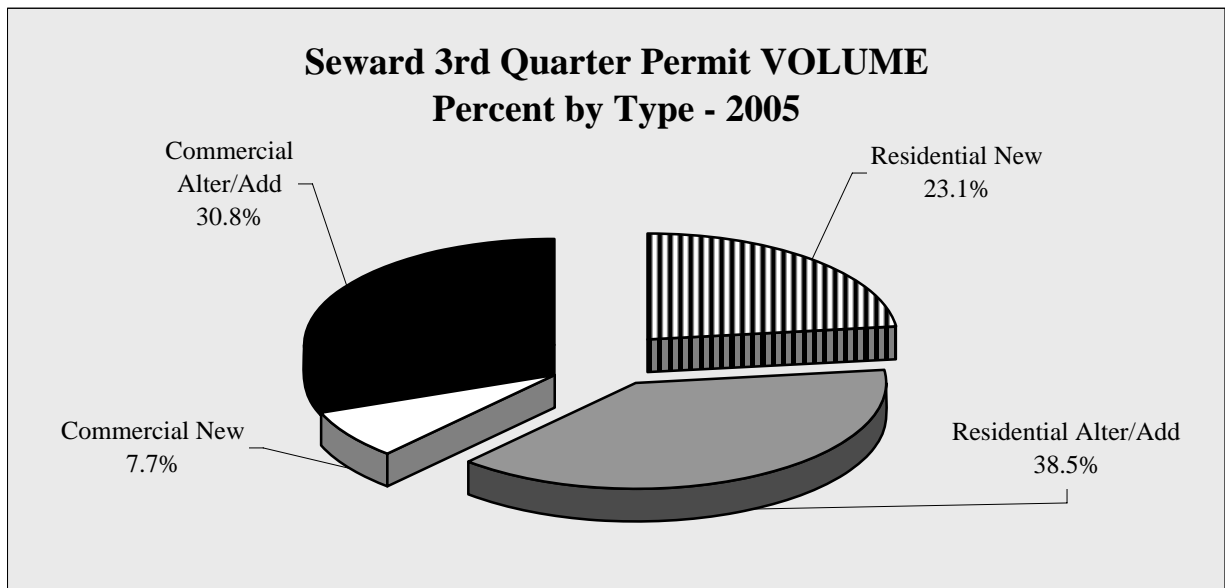

Chart 5.16

Seward Construction Permitting

Seward YTD 9/30 Permit VALUES by Type - 1999-2005

	1999	2000	2001	2002	2003	2004	2005	Annual Change
Residential New	1,094,400	1,023,000	150,000	725,000	1,077,500	2,130,000	1,898,000	-10.9%
Residential Alter/Add	241,600	106,600	239,214	222,208	244,500	492,400	118,581	-75.9%
Commercial New	1,153,275	625,000	486,028	4,044,730	4,285,000	13,018,800	358,420	-97.2%
Commercial Alter/Add	1,249,138	1,077,565	849,739	685,965	1,803,265	1,810,600	455,500	-74.8%
Total	3,738,413	2,832,165	1,724,981	5,677,903	7,410,265	17,451,800	2,830,501	-83.8%
Annual Change		-24.2%	-39.1%	229.2%	30.5%	135.5%	-83.8%	

Table 5.23

Seward YTD 9/30 Permit VALUES by Type - 1988-2005

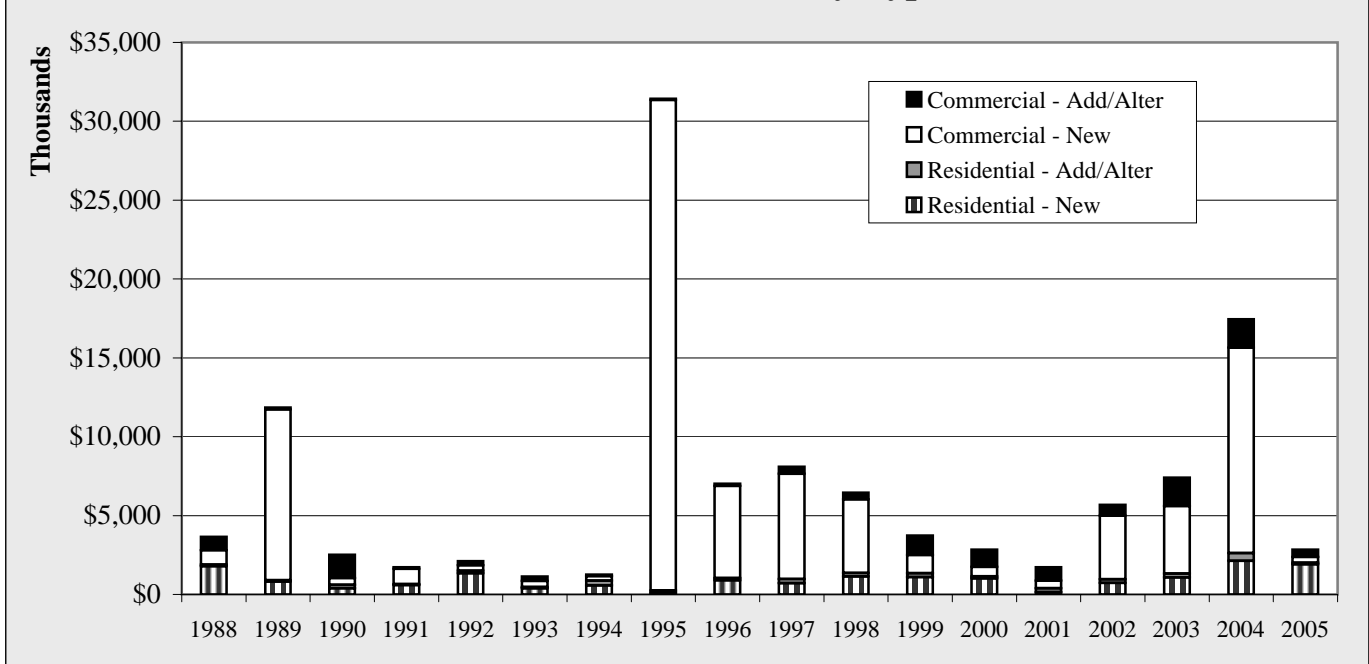

Chart 5.17

**Seward YTD 9/30 Permit VALUES
Percent by Type - 2005**

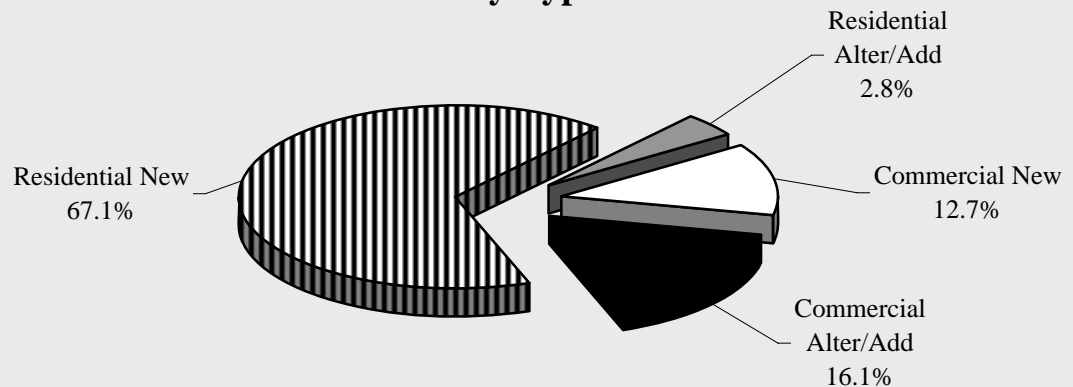

Chart 5.18

Seward Construction Permitting

Seward YTD 9/30 Permit VOLUME by Type - 1999-2005

	1999	2000	2001	2002	2003	2004	2005	Annual Change
Residential New	9	5	1	4	8	12	10	-16.7%
Residential Alter/Add	13	15	16	21	10	14	23	64.3%
Commercial New	6	7	6	5	6	4	5	25.0%
Commercial Alter/Add	18	15	16	23	15	17	9	-47.1%
Total	46	42	39	53	39	47	47	0.0%
Annual Change		-8.7%	-7.1%	35.9%	-26.4%	20.5%	0.0%	

Table 5.24

Seward YTD 9/30 Permit VOLUME by Type - 1988-2005

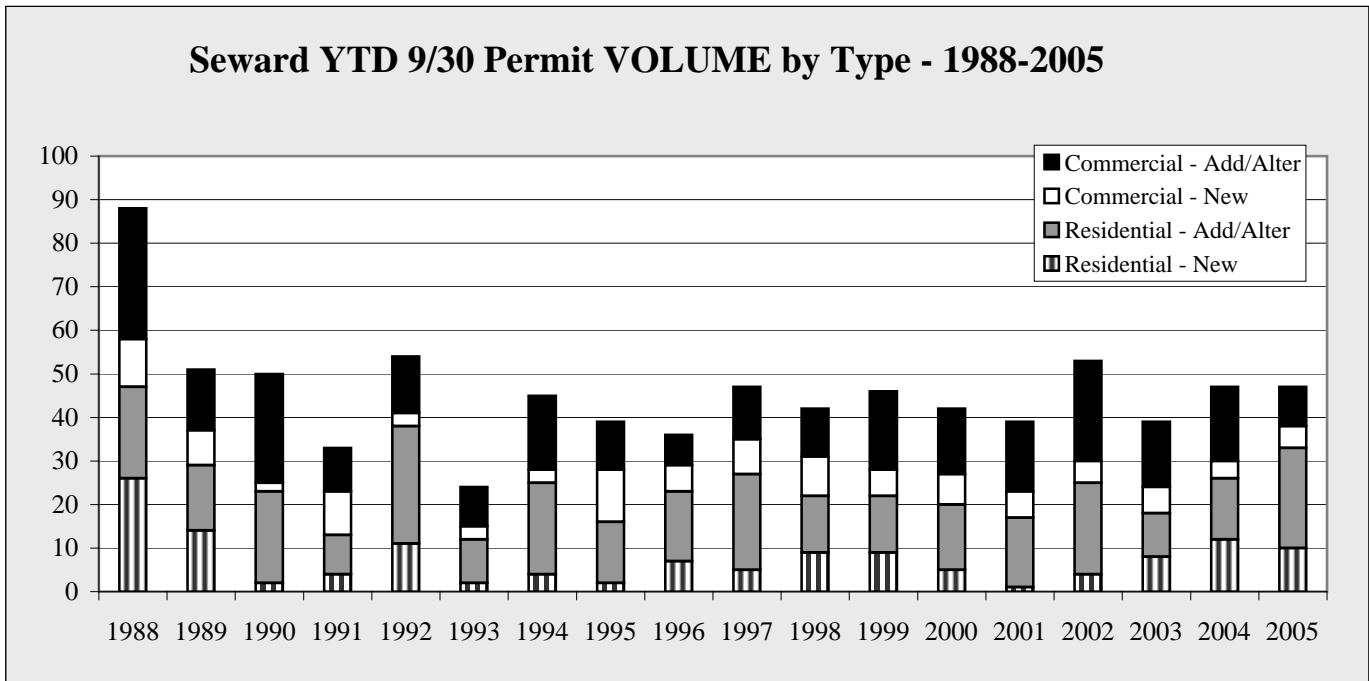

Chart 5.19

**Seward YTD 9/30 Permit VOLUME
Percent by Type - 2005**

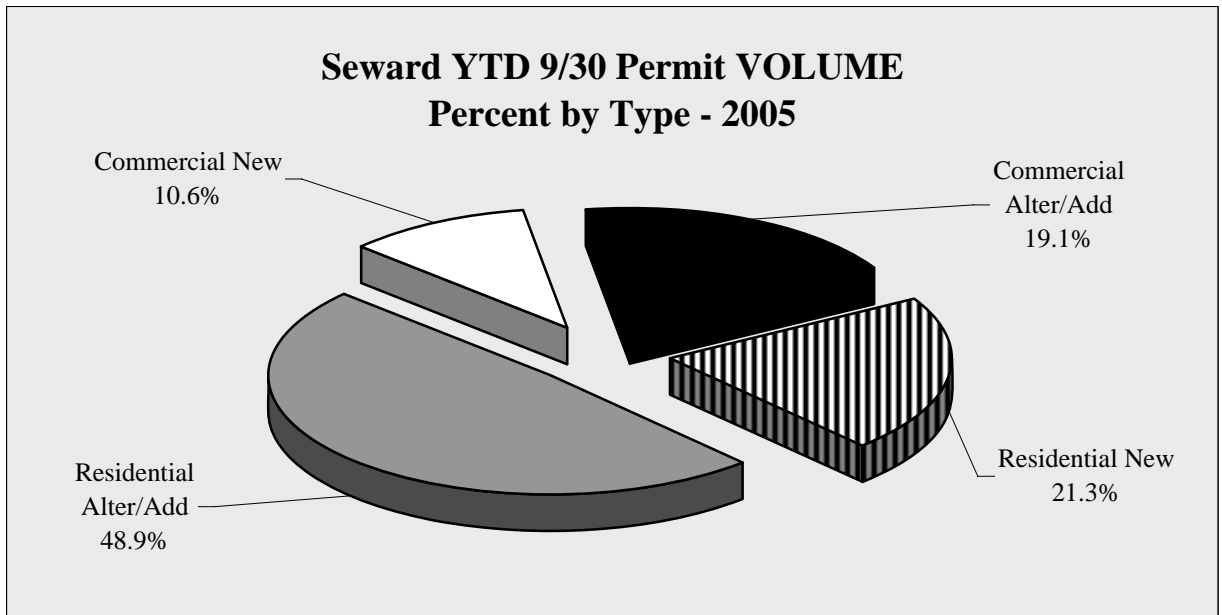

Chart 5.20

Seward Construction Permitting

Seward Annual Permit VALUES by Type - 1998-2004

	1998	1999	2000	2001	2002	2003	2004	Annual Change
Residential New	1,145,000	1,217,400	1,023,000	450,000	725,000	1,077,500	2,130,000	97.7%
Residential Alter/Add	240,543	256,600	446,000	344,214	242,008	294,500	500,400	69.9%
Commercial New	4,925,232	1,393,275	825,000	486,028	6,144,730	4,290,000	13,018,800	203.5%
Commercial Alter/Add	437,086	1,374,138	1,157,565	1,436,739	798,965	2,320,765	2,061,950	-11.2%
Total	6,747,861	4,241,413	3,451,565	2,716,981	7,910,703	7,982,765	17,711,150	121.9%
Annual Change		-37.1%	-18.6%	-21.3%	191.2%	0.9%	121.9%	

Table 5.25

Seward Annual Permit VALUES by Type - 1988-2004

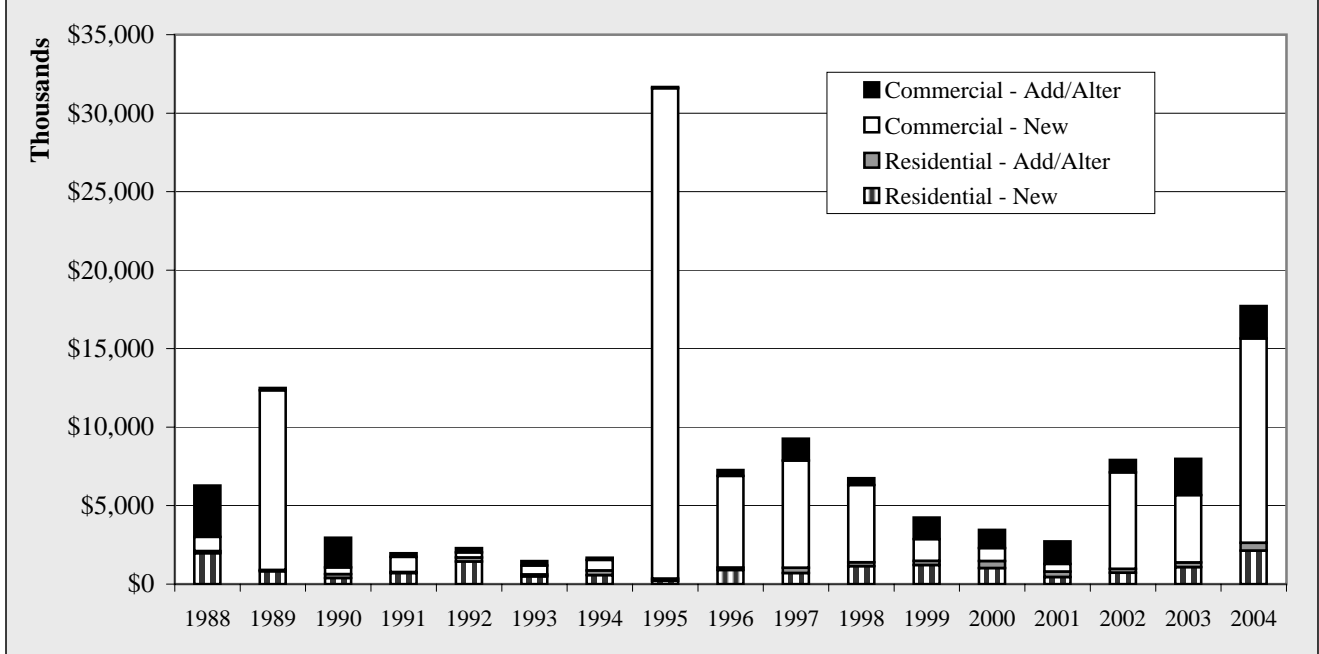

Chart 5.21

**Seward Annual Permit VALUES
Percent by Type - 2004**

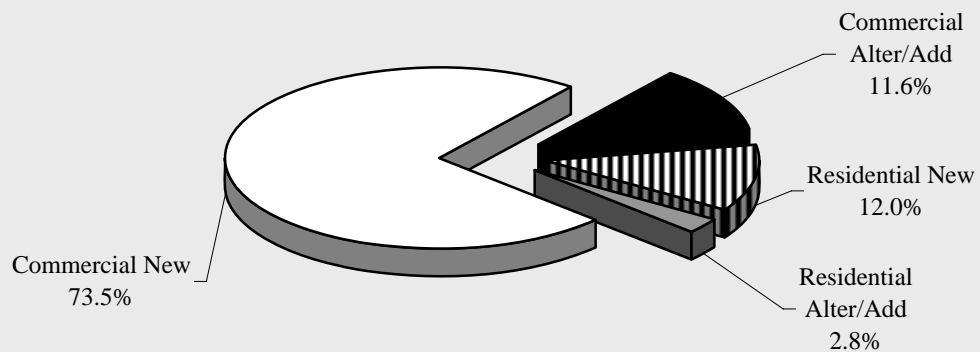

Chart 5.22

Seward Construction Permitting

Seward Annual Permit VOLUME by Type - 1998-2004

	1998	1999	2000	2001	2002	2003	2004	Annual Change
Residential New	9	10	5	3	4	8	12	50.0%
Residential Alter/Add	18	15	19	18	25	11	15	36.4%
Commercial New	10	7	8	6	8	7	4	-42.9%
Commercial Alter/Add	12	24	19	21	27	24	23	-4.2%
Total	49	56	51	48	64	50	54	8.0%
Annual Change		14.3%	-8.9%	-5.9%	33.3%	-21.9%	8.0%	

Table 5.26

Seward Annual Permit VOLUME by Type - 1988-2004

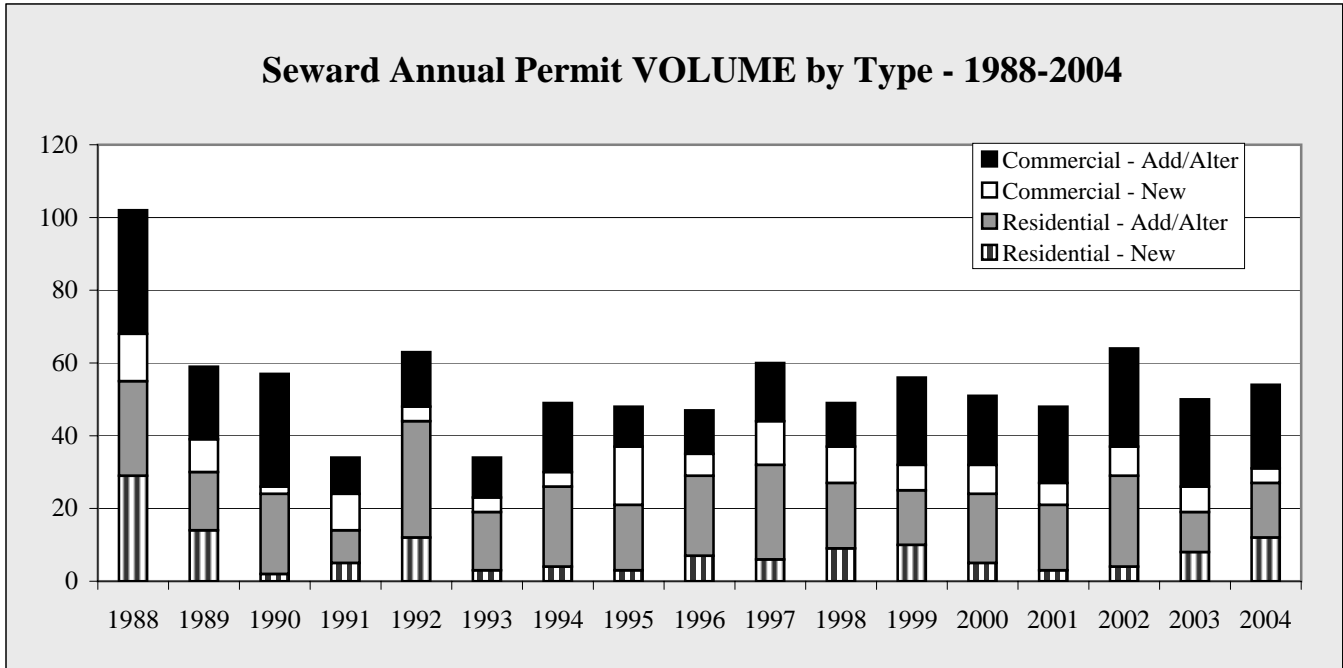

Chart 5.23

**Seward Annual Permit VOLUME
Percent by Type - 2004**

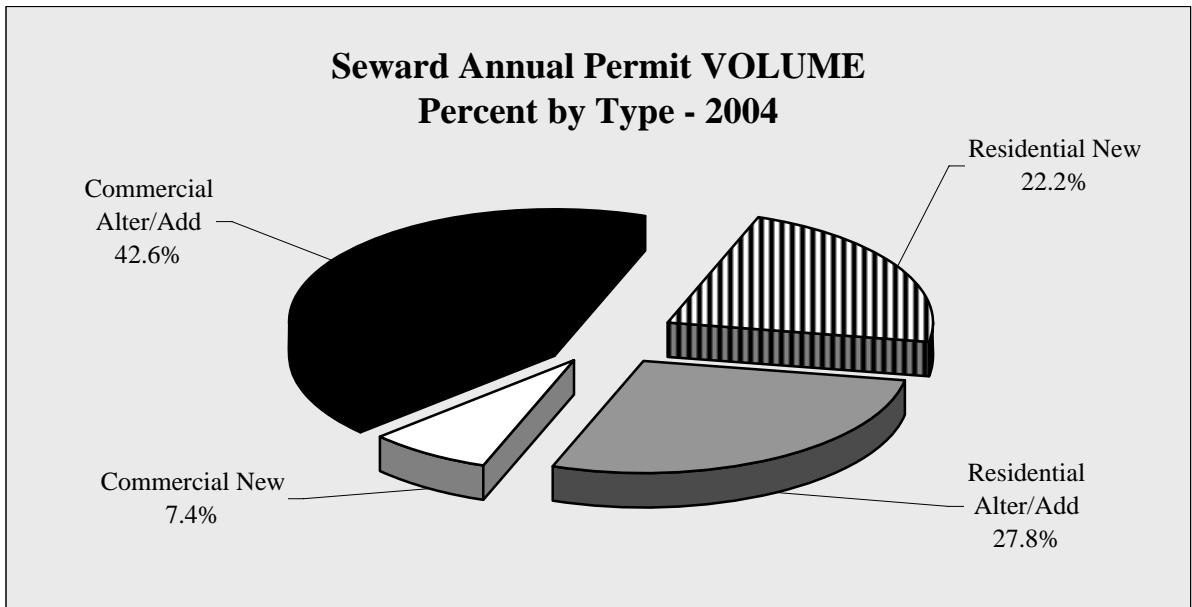

Chart 5.24

Seward Construction Permitting

Seward Annual Permit VALUES by Type by Quarter - 1998-2005 - in \$					
	1st Quarter	2nd Quarter	3rd Quarter	4th Quarter	Total
1998					
Residential - New	85,000	643,000	417,000	0	1,145,000
Residential - Add/Alter	25,043	122,000	59,000	34,500	240,543
Commercial - New	536,232	75,000	4,054,000	260,000	4,925,232
Commercial - Add/Alter	56,800	119,000	256,186	5,100	437,086
TOTAL	703,075	959,000	4,786,186	299,600	6,747,861
1999					
Residential - New	0	585,000	509,400	123,000	1,217,400
Residential - Add/Alter	5,200	164,500	71,900	15,000	256,600
Commercial - New	0	250,000	903,275	240,000	1,393,275
Commercial - Add/Alter	1,035,350	82,614	131,174	125,000	1,374,138
TOTAL	1,040,550	1,082,114	1,615,749	503,000	4,241,413
2000					
Residential - New	230,000	530,000	263,000	0	1,023,000
Residential - Add/Alter	0	67,600	39,000	339,400	446,000
Commercial - New	85,000	210,000	330,000	200,000	825,000
Commercial - Add/Alter	40,300	957,800	79,465	80,000	1,157,565
TOTAL	355,300	1,765,400	711,465	619,400	3,451,565
2001					
Residential - New	0	0	150,000	300,000	450,000
Residential - Add/Alter	30,200	73,000	136,014	105,000	344,214
Commercial - New	0	155,000	331,028	0	486,028
Commercial - Add/Alter	386,500	438,239	25,000	587,000	1,436,739
TOTAL	416,700	666,239	642,042	992,000	2,716,981
2002					
Residential - New	120,000	400,000	205,000	0	725,000
Residential - Add/Alter	25,496	169,157	27,555	19,800	242,008
Commercial - New	0	3,294,730	750,000	2,100,000	6,144,730
Commercial - Add/Alter	335,944	25,000	325,021	113,000	798,965
TOTAL	481,440	3,888,887	1,307,576	2,232,800	7,910,703
2003					
Residential - New	118,000	215,000	744,500	0	1,077,500
Residential - Add/Alter	57,500	100,000	87,000	50,000	294,500
Commercial - New	72,000	3,313,000	900,000	5,000	4,290,000
Commercial - Add/Alter	1,657,855	44,010	101,400	517,500	2,320,765
TOTAL	1,905,355	3,672,010	1,832,900	572,500	7,982,765
2004					
Residential - New	0	873,000	1,257,000	0	2,130,000
Residential - Add/Alter	48,000	144,900	299,500	8,000	500,400
Commercial - New	7,500,000	5,000,000	518,800	0	13,018,800
Commercial - Add/Alter	193,600	1,426,000	191,000	251,350	2,061,950
TOTAL	7,741,600	7,443,900	2,266,300	259,350	17,711,150
2005					
					Year to Date
Residential - New	1,055,000	388,000	455,000		1,898,000
Residential - Add/Alter	6,300	105,520	6,761		118,581
Commercial - New	206,000	71,020	81,400		358,420
Commercial - Add/Alter	240,000	105,000	110,500		455,500
TOTAL	1,507,300	669,540	653,661		2,830,501

Table 5.27

Seward Construction Permitting

Seward Annual Permit VOLUME by Type by Quarter - 1998-2005					
	1st Quarter	2nd Quarter	3rd Quarter	4th Quarter	Total
1998					
Residential - New	1	6	2	0	9
Residential - Add/Alter	4	4	5	5	18
Commercial - New	2	3	4	1	10
Commercial - Add/Alter	2	7	2	1	12
TOTAL	9	20	13	7	49
1999					
Residential - New	0	5	4	1	10
Residential - Add/Alter	1	7	5	2	15
Commercial - New	0	1	5	1	7
Commercial - Add/Alter	4	5	9	6	24
TOTAL	5	18	23	10	56
2000					
Residential - New	1	2	2	0	5
Residential - Add/Alter	0	8	7	4	19
Commercial - New	1	3	3	1	8
Commercial - Add/Alter	3	7	5	4	19
TOTAL	5	20	17	9	51
2001					
Residential - New	0	0	1	2	3
Residential - Add/Alter	4	3	9	2	18
Commercial - New	0	3	3	0	6
Commercial - Add/Alter	7	8	1	5	21
TOTAL	11	14	14	9	48
2002					
Residential - New	1	1	2	0	4
Residential - Add/Alter	3	15	3	4	25
Commercial - New	0	4	1	3	8
Commercial - Add/Alter	6	9	8	4	27
TOTAL	10	29	14	11	64
2003					
Residential - New	1	2	5	0	8
Residential - Add/Alter	2	3	5	1	11
Commercial - New	1	4	1	1	7
Commercial - Add/Alter	7	4	4	9	24
TOTAL	11	13	15	11	50
2004					
Residential - New	0	4	8	0	12
Residential - Add/Alter	2	7	5	1	15
Commercial - New	1	1	2	0	4
Commercial - Add/Alter	4	9	4	6	23
TOTAL	7	21	19	7	54
2005					Year to Date
Residential - New	4	3	3		10
Residential - Add/Alter	3	15	5		23
Commercial - New	2	2	1		5
Commercial - Add/Alter	4	1	4		9
TOTAL	13	21	13		47

Table 5.28

Seward Cost of Food

Cost of food data is collected by the University of Alaska, Fairbanks Cooperative Extension. Each quarter the Cooperative Extension surveys up to three grocers in communities throughout the state to determine the cost of food for one week. Specific guidelines are presented to the surveyors regarding item size and sale price for 104 items.

SEWARD							
	September 2000	September 2001	September 2002	September 2003	September 2004	September 2005	Annual Change
Sales Tax Rate	5.0	5.0	5.0	5.0	6.0	6.00	
Percent of Food Unavailable	0.0	3.0	2.0	2.0	1.0	0.00	
Child, 1 year	5.00	20.24	18.29	19.49	20.93	20.00	-4.4%
Child, 2 years	0.00	20.24	18.29	19.49	20.71	19.77	-4.5%
Children 3-5 years of age	19.25	22.26	20.07	21.22	22.88	21.78	-4.8%
Children 6-8 years of age	25.55	29.60	26.83	28.39	30.57	29.32	-4.1%
Children 9-11 years of age	28.97	33.53	30.44	32.06	34.52	33.08	-4.2%
Males 12-14 years of age	32.84	37.96	34.39	36.19	39.02	37.37	-4.2%
Males 15-19 years of age	33.83	39.17	35.47	37.30	40.08	38.52	-3.9%
Males 20-50 years of age	33.65	38.96	35.39	37.21	40.17	38.48	-4.2%
Males 51 and older	32.03	36.94	33.68	35.47	38.23	36.55	-4.4%
Females 12-19 years of age	28.25	32.71	29.53	31.23	33.62	32.24	-4.1%
Females 20-50 years of age	29.42	33.92	30.88	32.44	34.96	33.47	-4.3%
Females 51 and older	28.52	33.02	29.98	31.51	34.02	32.52	-4.4%
Family of 2, 20-50 years of age	69.37	80.18	72.89	76.63	82.66	79.13	-4.3%
Family of 2, 51 years and older	66.58	76.95	70.02	73.68	79.48	75.99	-4.4%
Family of 4, children 1-5 years	99.78	115.38	104.62	110.17	118.74	113.48	-4.4%
Family of 4, children 6-11 years	117.60	136.01	123.53	130.10	140.23	134.34	-4.2%
Electricity, 1000 kWh	129.39	132.80	134.34	131.98	139.95	151.31	8.1%
Heating Oil, 55 gal	89.10	79.20	83.05	84.15	101.75	144.10	41.6%
Gasoline, auto, 55 gal	101.20	101.20	94.60	104.50	118.80	161.70	36.1%
Lumber, 2X4X8	2.84	2.84	3.25	2.74	3.70	3.70	0.0%
Propane, 100 lb. Refill	48.38	48.62	48.38	56.29	60.18	76.70	27.5%

Table 5.29

Seward Cost of Food

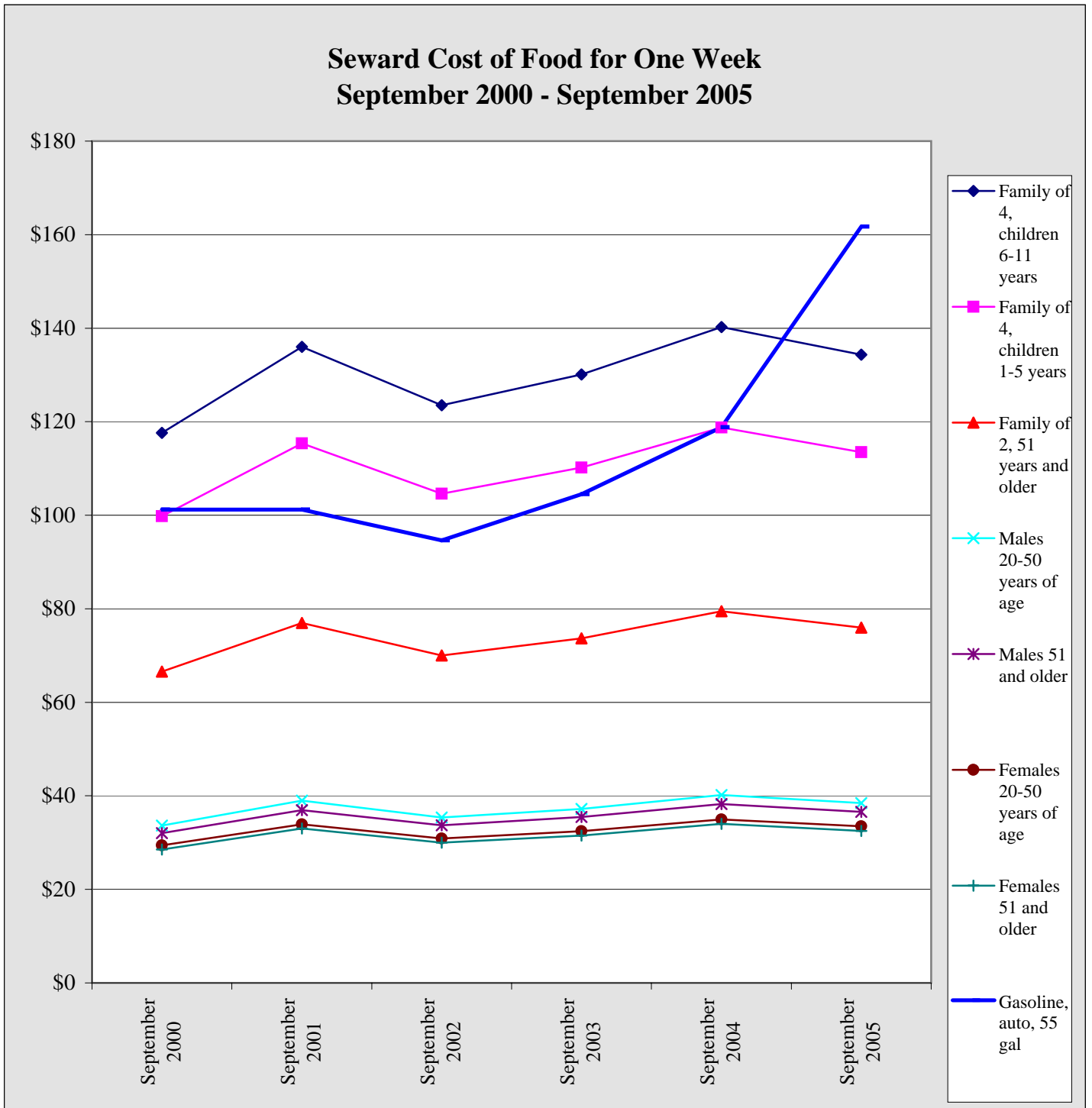

Chart 5.25

Soldotna Sales

Soldotna 3rd Quarter GROSS Sales by Industry - 1999-2005 - in \$

	1999	2000	2001	2002	2003	2004	2005	Annual Change
AFF	409,810	927,816	693,279	667,821	920,446	1,043,046	1,238,356	18.7%
Min	74,797	53,453	124,429	86,164	99,139	136,149	229,355	68.5%
Const	5,287,743	6,697,977	6,018,641	8,313,280	6,733,409	9,248,884	9,599,552	3.8%
Manu	1,312,635	2,222,599	2,098,063	2,352,093	2,843,498	1,857,842	2,001,565	7.7%
TCPU	4,616,295	3,994,588	4,556,940	4,900,494	3,716,921	5,692,042	5,432,771	-4.6%
Whole	12,343,776	11,890,501	10,894,321	12,524,522	10,562,562	3,326,912	3,754,246	12.8%
Retail	51,893,943	50,862,968	57,845,073	60,884,442	65,995,934	70,283,879	74,563,370	6.1%
FIRE	2,304,498	3,135,684	2,932,358	2,591,812	2,839,072	2,839,045	2,906,572	2.4%
Service	9,455,476	9,742,934	10,501,170	11,299,921	12,543,766	12,762,242	13,345,399	4.6%
Govt	5,233	1,781	6,158	4,290	12,192	2,880	11,907	313.4%
Total	87,704,206	89,530,301	95,670,432	103,624,839	106,266,939	107,192,921	113,083,093	5.5%
Annual Change		2.1%	6.9%	8.3%	2.5%	0.9%	5.5%	

Table 6.1

Soldotna 3rd Quarter GROSS Sales Ten Year Change by INDUSTRY - 1995 v. 2005 - in \$

			10 Year Change	
	1995	2005	Percentage	Numerical
AFF	345,979	1,238,356	257.9%	892,377
Min	221,443	229,355	3.6%	7,912
Const	4,969,031	9,599,552	93.2%	4,630,521
Manu	1,191,207	2,001,565	68.0%	810,358
TCPU	3,472,190	5,432,771	56.5%	1,960,581
Whole	3,111,205	3,754,246	20.7%	643,041
Retail	41,700,346	74,563,370	78.8%	32,863,024
FIRE	2,286,982	2,906,572	27.1%	619,590
Service	7,423,983	13,345,399	79.8%	5,921,416
Govt	2,017	11,907	0.0%	9,890
Total	64,724,383	113,083,093	74.7%	48,358,710

Table 6.2

Soldotna 3rd Quarter GROSS Sales One Year Change by INDUSTRY - 2004 v. 2005 - in \$

			1 Year Change	
	2004	2005	Percentage	Numerical
AFF	1,043,046	1,238,356	18.7%	195,310
Min	136,149	229,355	68.5%	93,206
Const	9,248,884	9,599,552	3.8%	350,668
Manu	1,857,842	2,001,565	7.7%	143,723
TCPU	5,692,042	5,432,771	-4.6%	-259,271
Whole	3,326,912	3,754,246	12.8%	427,334
Retail	70,283,879	74,563,370	6.1%	4,279,491
FIRE	2,839,045	2,906,572	2.4%	67,527
Service	12,762,242	13,345,399	4.6%	583,157
Govt	2,880	11,907	313.4%	9,027
Total	107,192,921	113,083,093	5.5%	5,890,172

Table 6.3

Soldotna 3rd Quarter Comparative GROSS Sales by Industry 2003, 2004, 2005

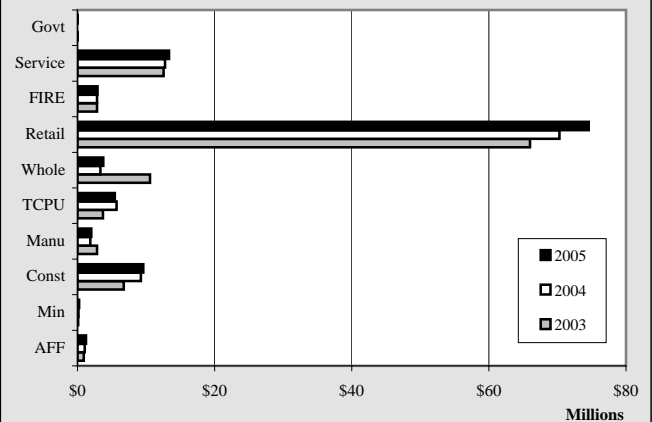

Chart 6.1

Soldotna 3rd Quarter GROSS Sales 1991-2005

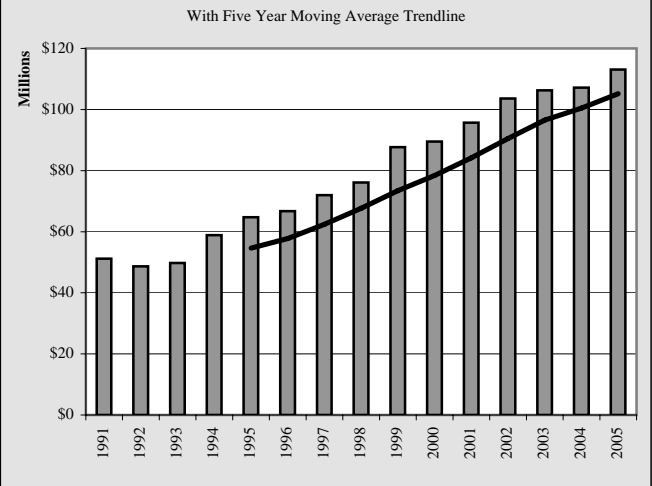

Chart 6.2

Soldotna Sales

Soldotna 3rd Quarter TAXABLE Sales by Industry - 1999-2005 - in							
	1999	2000	2001	2002	2003	2004	2005
AFF	248,328	346,853	413,211	393,521	457,868	444,134	486,480
Min	1,765	2,240	8,962	7,836	7,885	3,030	6,831
Const	420,863	330,069	353,143	369,398	464,677	369,202	391,911
Manu	630,134	716,528	676,627	710,329	739,665	804,097	754,317
TCPU	2,540,061	2,613,036	2,661,503	2,944,886	2,959,644	2,949,371	3,186,012
Whole	100,208	272,833	250,422	251,226	339,309	263,334	265,431
Retail	40,239,495	39,854,847	43,274,819	45,546,360	50,726,050	53,989,889	57,213,872
FIRE	1,125,039	1,375,621	1,551,525	1,502,411	1,176,522	1,279,786	1,179,694
Service	5,189,435	5,009,375	4,946,878	5,758,366	5,694,959	6,072,228	6,083,566
Govt	5,233	1,781	6,158	4,290	12,192	2,880	11,907
Total	50,500,561	50,523,183	54,143,248	57,488,623	62,578,771	66,177,951	69,580,021
Annual Change		0.0%	7.2%	6.2%	8.9%	5.8%	5.1%

Table 6.4

Soldotna 3rd Quarter TAXABLE Sales Ten Year Change by INDUSTRY - 1995 v. 2005 - in \$				
	10 Year Change			
	1995	2005	Percentage	Numerical
AFF	119,926	486,480	305.7%	366,554
Min	5,324	6,831	28.3%	1,507
Const	351,822	391,911	11.4%	40,089
Manu	448,209	754,317	68.3%	306,108
TCPU	2,119,727	3,186,012	50.3%	1,066,285
Whole	87,991	265,431	201.7%	177,440
Retail	32,189,209	57,213,872	77.7%	25,024,663
FIRE	1,166,732	1,179,694	1.1%	12,962
Service	4,690,944	6,083,566	29.7%	1,392,622
Govt	2,017	11,907	490.3%	9,890
Total	41,181,901	69,580,021	69.0%	28,398,120

Table 6.5

Soldotna 3rd Quarter TAXABLE Sales One Year Change by INDUSTRY - 2004 v. 2005 - in \$				
	1 Year Change			
	2004	2005	Percentage	Numerical
AFF	444,134	486,480	9.5%	42,346
Min	3,030	6,831	0.0%	3,801
Const	369,202	391,911	6.2%	22,709
Manu	804,097	754,317	-6.2%	-49,780
TCPU	2,949,371	3,186,012	8.0%	236,641
Whole	263,334	265,431	0.8%	2,097
Retail	53,989,889	57,213,872	6.0%	3,223,983
FIRE	1,279,786	1,179,694	-7.8%	-100,092
Service	6,072,228	6,083,566	0.2%	11,338
Govt	2,880	11,907	313.4%	9,027
Total	66,177,951	69,580,021	5.1%	3,402,070

Table 6.6

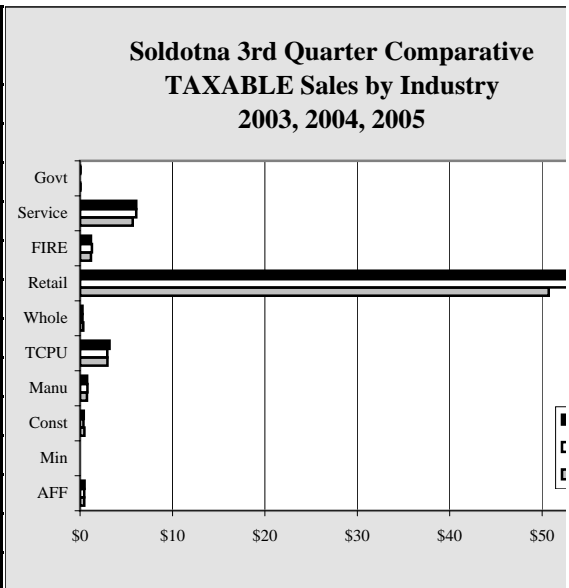

Chart 6.3

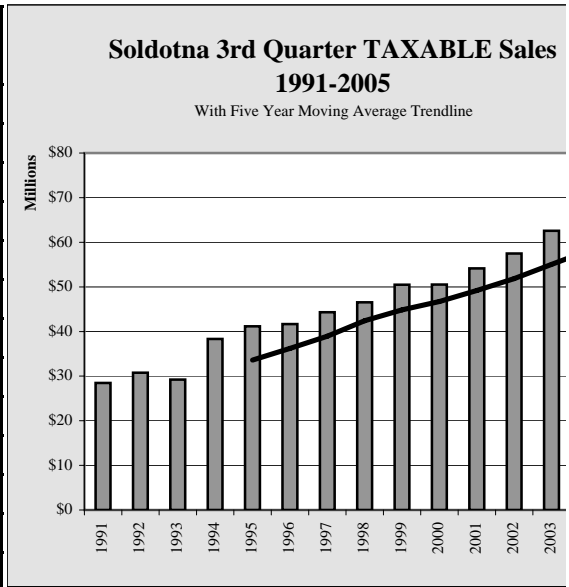
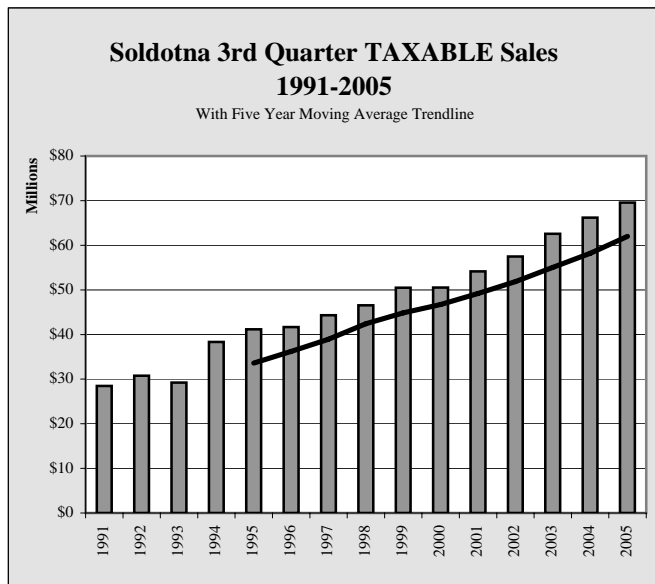
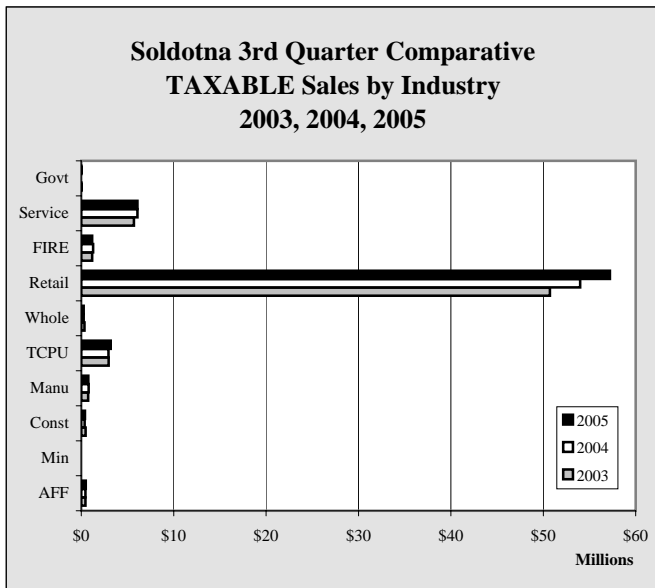

Chart 6.4

Soldotna Sales

\$	
Annual Change	
	9.5%
	125.4%
	6.2%
	-6.2%
	8.0%
	0.8%
	6.0%
	-7.8%
	0.2%
	313.4%
	5.1%



Soldotna Sales

Soldotna YTD 9/30 GROSS Sales by Industry - 1999-2005 - in \$								
	1999	2000	2001	2002	2003	2004	2005	Annual Change
AFF	736,399	1,465,090	1,395,255	1,392,318	1,765,925	2,245,603	2,846,723	26.8%
Min	225,625	204,950	251,787	291,214	331,780	383,222	505,323	31.9%
Const	10,766,420	14,668,275	14,498,458	16,476,287	14,685,475	18,084,547	19,277,916	6.6%
Manu	2,558,859	4,013,509	4,677,028	4,980,601	6,261,037	3,534,082	3,889,417	10.1%
TCPU	12,987,032	11,718,392	13,894,541	12,117,670	11,755,500	15,205,236	16,228,013	6.7%
Whole	24,945,812	27,891,197	24,702,623	27,950,092	27,426,442	22,014,611	8,896,367	-59.6%
Retail	125,170,443	124,938,486	138,250,559	146,432,318	154,954,380	163,913,198	172,925,662	5.5%
FIRE	6,441,457	7,855,115	7,322,353	7,833,735	7,867,094	8,830,077	8,775,927	-0.6%
Service	23,152,259	24,477,551	26,504,713	28,225,153	30,662,293	32,201,009	33,286,739	3.4%
Govt	24,822	14,847	17,903	18,849	33,191	18,305	22,306	21.9%
Total	207,009,128	217,247,412	231,515,220	245,718,237	255,743,117	266,429,890	266,654,393	0.1%
Annual Change		4.9%	6.6%	6.1%	4.1%	4.2%	0.1%	

Table 6.7

Soldotna YTD 9/30 GROSS Sales Ten Year Change by INDUSTRY - 1995 v. 2005 - in \$				
	10 Year Change			
	1995	2005	Percentage	Numerical
AFF	554,709	2,846,723	413.2%	2,292,014
Min	511,197	505,323	-1.1%	-5,874
Const	12,459,773	19,277,916	54.7%	6,818,143
Manu	2,670,625	3,889,417	45.6%	1,218,792
TCPU	9,871,066	16,228,013	64.4%	6,356,947
Whole	9,220,888	8,896,367	-3.5%	-324,521
Retail	99,320,188	172,925,662	74.1%	73,605,474
FIRE	5,894,928	8,775,927	48.9%	2,880,999
Service	18,204,554	33,286,739	82.8%	15,082,185
Govt	7,007	22,306	218.3%	15,299
Total	158,714,935	266,654,393	68.0%	107,939,458

Table 6.8

Soldotna YTD 9/30 GROSS Sales One Year Change by INDUSTRY - 2004 v. 2005 - in \$				
	1 Year Change			
	2004	2005	Percentage	Numerical
AFF	2,245,603	2,846,723	26.8%	601,120
Min	383,222	505,323	0.0%	122,101
Const	18,084,547	19,277,916	6.6%	1,193,369
Manu	3,534,082	3,889,417	10.1%	355,335
TCPU	15,205,236	16,228,013	6.7%	1,022,777
Whole	22,014,611	8,896,367	-59.6%	-13,118,244
Retail	163,913,198	172,925,662	5.5%	9,012,464
FIRE	8,830,077	8,775,927	-0.6%	-54,150
Service	32,201,009	33,286,739	3.4%	1,085,730
Govt	18,305	22,306	21.9%	4,001
Total	266,429,890	266,654,393	0.1%	224,503

Table 6.9

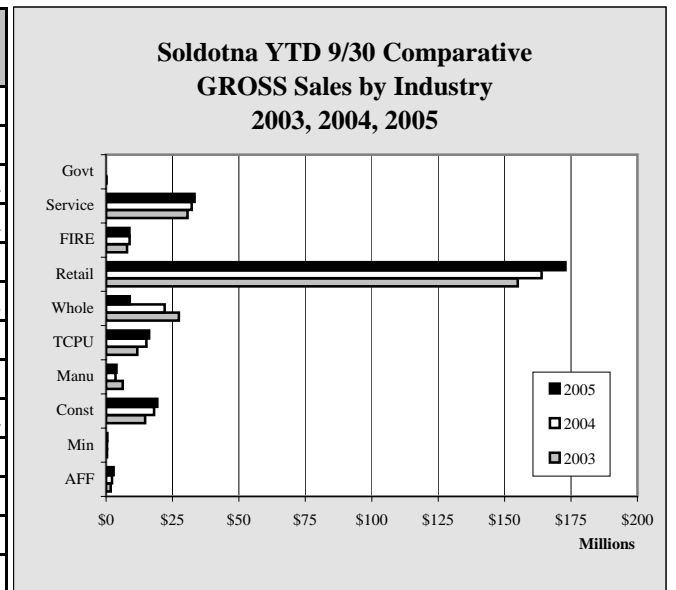

Chart 6.5

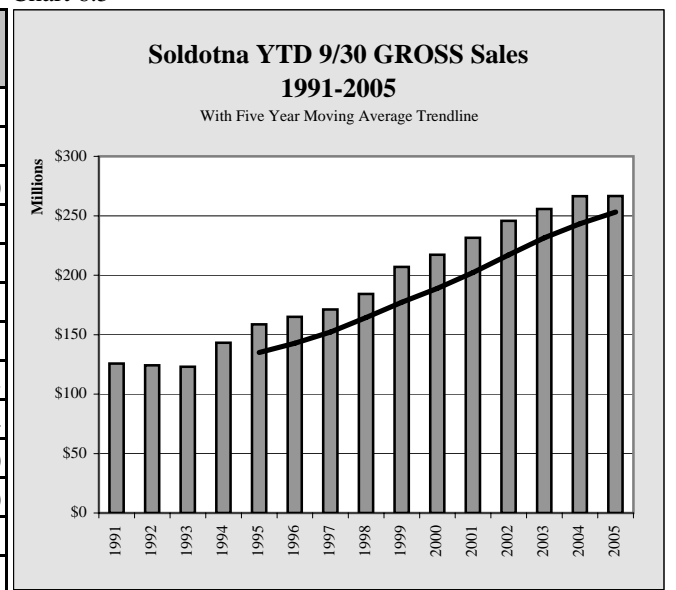

Chart 6.6

Soldotna Sales

Soldotna YTD 9/30 TAXABLE Sales by Industry - 1999-2005 - in \$							
	1999	2000	2001	2002	2003	2004	2005
AFF	513,472	722,179	911,120	865,338	922,887	934,277	932,429
Min	4,215	10,095	26,816	21,697	24,660	15,533	19,965
Const	1,107,447	936,249	889,468	982,300	1,196,874	1,062,592	1,135,429
Manu	1,201,201	1,323,915	1,341,850	1,321,142	1,395,734	1,377,663	1,350,029
TCPU	7,587,129	7,793,164	7,830,514	8,316,315	9,142,862	9,272,904	9,700,938
Whole	240,397	573,422	657,940	617,727	800,989	671,922	647,261
Retail	91,390,900	92,220,749	101,843,920	104,839,901	113,452,859	121,236,465	129,084,452
FIRE	2,896,505	3,302,728	3,846,126	3,939,711	3,488,424	3,372,813	3,234,504
Service	12,179,641	12,056,871	12,184,042	13,806,185	13,604,062	14,609,734	14,328,154
Govt	24,822	14,847	17,903	18,849	33,191	18,305	22,306
Total	117,145,729	118,954,219	129,549,699	134,729,165	144,062,542	152,572,208	160,455,467
Annual Change		1.5%	8.9%	4.0%	6.9%	5.9%	5.2%

Table 6.10

Soldotna YTD 9/30 TAXABLE Sales Ten Year Change by INDUSTRY - 1995 v. 2005 - in \$				
	10 Year Change			
	1995	2005	Percentage	Numerical
AFF	284,670	932,429	227.5%	647,759
Min	5,823	19,965	242.9%	14,142
Const	871,642	1,135,429	30.3%	263,787
Manu	1,079,081	1,350,029	25.1%	270,948
TCPU	6,342,463	9,700,938	53.0%	3,358,475
Whole	249,391	647,261	159.5%	397,870
Retail	73,878,169	129,084,452	74.7%	55,206,283
FIRE	3,004,178	3,234,504	7.7%	230,326
Service	11,197,955	14,328,154	28.0%	3,130,199
Govt	7,007	22,306	218.3%	15,299
Total	96,920,379	160,455,467	65.6%	63,535,088

Table 6.11

Soldotna YTD 9/30 TAXABLE Sales One Year Change by INDUSTRY - 2004 v. 2005 - in \$				
	1 Year Change			
	2004	2005	Percentage	Numerical
AFF	934,277	932,429	-0.2%	-1,848
Min	15,533	19,965	0.0%	4,432
Const	1,062,592	1,135,429	6.9%	72,837
Manu	1,377,663	1,350,029	-2.0%	-27,634
TCPU	9,272,904	9,700,938	4.6%	428,034
Whole	671,922	647,261	-3.7%	-24,661
Retail	121,236,465	129,084,452	6.5%	7,847,987
FIRE	3,372,813	3,234,504	-4.1%	-138,309
Service	14,609,734	14,328,154	-1.9%	-281,580
Govt	18,305	22,306	21.9%	4,001
Total	152,572,208	160,455,467	5.2%	7,883,259

Table 6.12

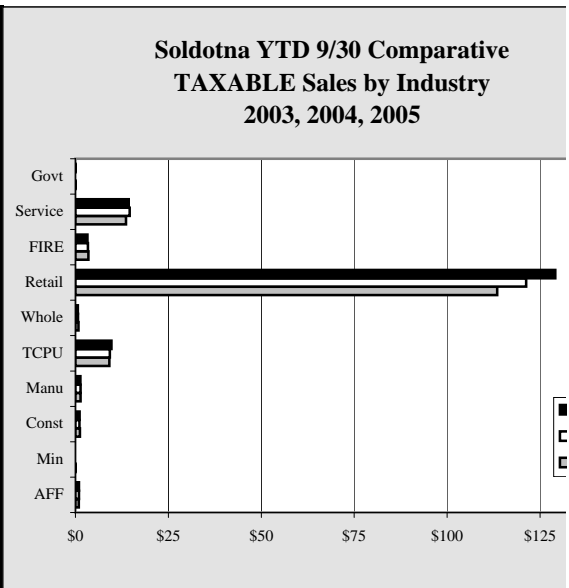

Chart 6.7

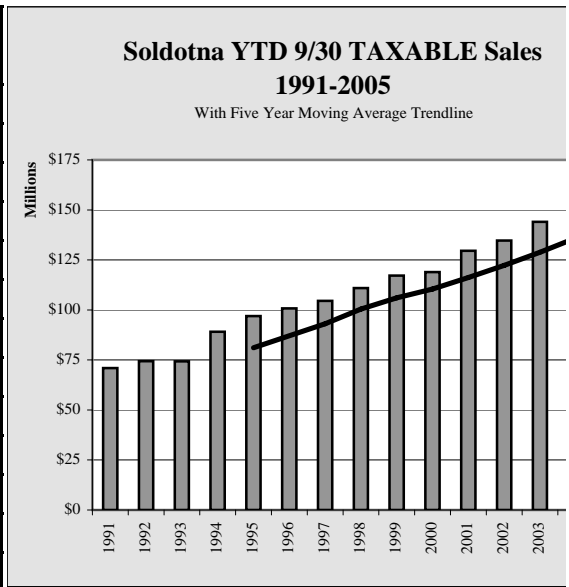
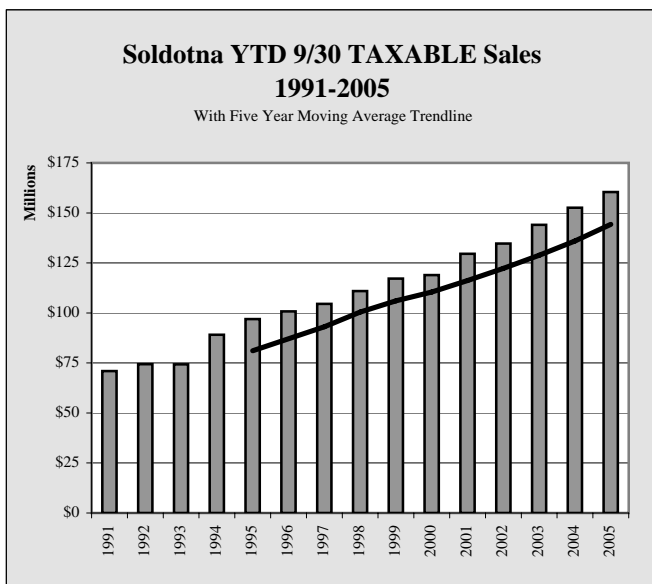
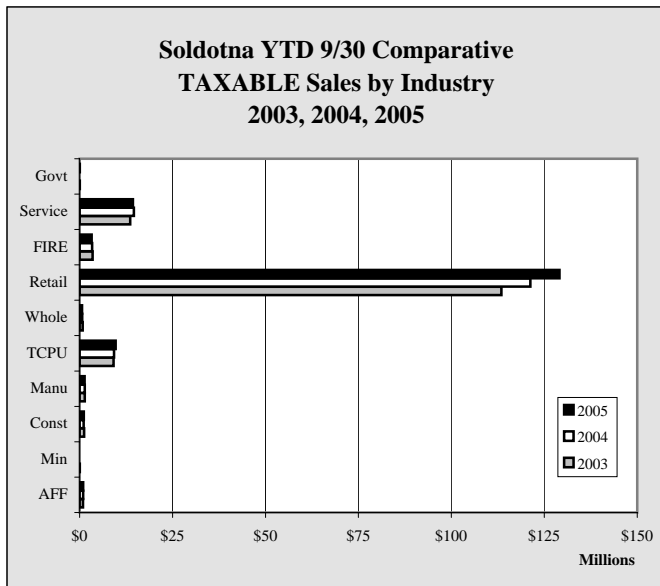

Chart 6.8

Soldotna Sales

Annual Change
-0.2%
28.5%
6.9%
-2.0%
4.6%
-3.7%
6.5%
-4.1%
-1.9%
21.9%
5.2%



Soldotna Sales

Soldotna Annual GROSS Sales by Industry - 1998-2004 - in \$								
	1998	1999	2000	2001	2002	2003	2004	Annual Change
AFF	689,389	954,143	1,727,448	1,664,917	1,853,591	2,523,473	3,223,216	27.7%
Min	2,729,541	306,689	305,525	305,091	410,684	450,504	548,472	21.7%
Const	20,205,240	17,075,443	20,761,485	19,395,458	22,467,091	20,811,207	27,763,211	33.4%
Manu	3,192,979	3,210,218	5,446,988	5,938,040	6,301,658	7,729,281	4,338,040	-43.9%
TCPU	14,308,591	17,467,668	15,708,998	17,799,215	15,900,605	16,342,600	20,221,946	23.7%
Whole	14,626,150	32,515,047	32,610,279	31,467,653	40,201,769	34,368,869	28,770,110	-16.3%
Retail	157,774,054	166,898,488	170,201,586	187,606,859	191,944,180	204,697,590	217,632,663	6.3%
FIRE	7,365,455	8,509,983	10,210,170	10,232,574	10,465,959	10,779,337	11,901,005	10.4%
Service	29,884,044	30,622,659	32,265,770	34,689,321	36,330,903	40,153,657	46,823,371	16.6%
Govt	18,221	28,399	17,062	19,103	22,579	41,717	20,979	-49.7%
Total	250,793,664	277,588,737	289,255,311	309,118,231	325,899,019	337,898,235	361,243,013	6.9%
Annual Change		10.7%	4.2%	6.9%	5.4%	3.7%	6.9%	

Table 6.13

Soldotna Annual GROSS Sales Ten Year Change by INDUSTRY - 1994 v. 2004 - in \$				
	10 Year Change			
	1994	2004	Percentage	Numerical
AFF	551,362	3,223,216	484.6%	2,671,854
Min	688,642	548,472	-20.4%	-140,170
Const	15,339,238	27,763,211	81.0%	12,423,973
Manu	2,423,390	4,338,040	79.0%	1,914,650
TCPU	12,546,783	20,221,946	61.2%	7,675,163
Whole	11,992,928	28,770,110	139.9%	16,777,182
Retail	120,712,359	217,632,663	80.3%	96,920,304
FIRE	7,992,389	11,901,005	48.9%	3,908,616
Service	22,354,962	46,823,371	109.5%	24,468,409
Govt	7,491	20,979	180.1%	13,488
Total	194,609,544	361,243,013	85.6%	166,633,469

Table 6.14

Soldotna Annual GROSS Sales One Year Change by INDUSTRY - 2003 v. 2004 - in \$				
	1 Year Change			
	2003	2004	Percentage	Numerical
AFF	2,523,473	3,223,216	27.7%	699,743
Min	450,504	548,472	0.0%	97,968
Const	20,811,207	27,763,211	33.4%	6,952,004
Manu	7,729,281	4,338,040	-43.9%	-3,391,241
TCPU	16,342,600	20,221,946	23.7%	3,879,346
Whole	34,368,869	28,770,110	-16.3%	-5,598,759
Retail	204,697,590	217,632,663	6.3%	12,935,073
FIRE	10,779,337	11,901,005	10.4%	1,121,668
Service	40,153,657	46,823,371	16.6%	6,669,714
Govt	41,717	20,979	-49.7%	-20,738
Total	337,898,235	361,243,013	6.9%	23,344,778

Table 6.15

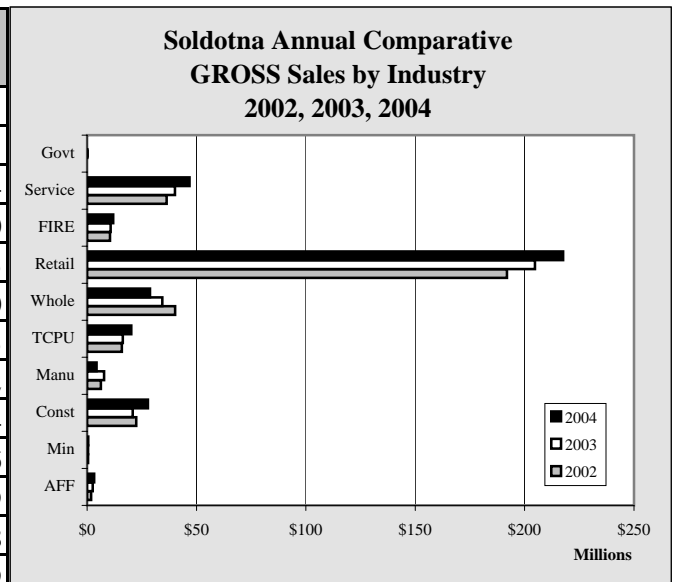

Chart 6.9

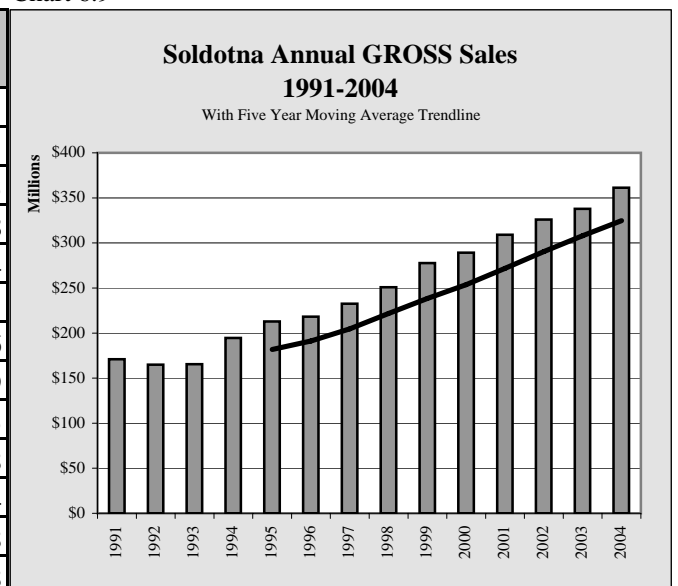

Chart 6.10

Soldotna Sales

Soldotna Annual TAXABLE Sales by Industry - 1998-2004 - in \$								
	1998	1999	2000	2001	2002	2003	2004	Annual Change
AFF	466,912	697,062	921,908	1,117,793	1,043,812	1,176,634	1,123,088	-4.6%
Min	8,010	5,675	11,333	35,080	33,278	33,067	20,326	-38.5%
Const	1,320,297	1,471,239	1,233,755	1,173,265	1,317,838	1,588,752	1,413,366	-11.0%
Manu	1,439,440	1,467,864	1,567,147	1,638,254	1,635,572	1,674,325	1,663,082	-0.7%
TCPU	9,374,360	10,378,566	10,311,502	10,527,433	11,178,060	12,295,182	12,421,267	1.0%
Whole	369,062	322,925	715,161	786,443	763,236	997,320	805,376	-19.2%
Retail	115,732,671	122,401,180	124,618,575	136,194,643	138,178,507	151,124,891	159,825,313	5.8%
FIRE	3,662,452	3,776,435	4,545,775	5,207,613	5,279,203	4,480,551	4,387,668	-2.1%
Service	15,398,236	15,403,419	15,493,910	15,718,811	17,525,783	17,208,443	18,364,346	6.7%
Govt	18,221	28,399	17,062	19,103	22,579	41,717	20,979	-49.7%
Total	147,789,661	155,952,764	159,436,128	172,418,438	176,977,868	190,620,882	200,044,811	4.9%
Annual Change		5.5%	2.2%	8.1%	2.6%	7.7%	4.9%	

Table 6.16

Soldotna Annual TAXABLE Sales Ten Year Change by INDUSTRY - 1994 v. 2004 - in \$				
			10 Year Change	
	1994	2004	Percentage	Numerical
AFF	334,453	1,123,088	235.8%	788,635
Min	4,896	20,326	315.2%	15,430
Const	1,071,799	1,413,366	31.9%	341,567
Manu	1,169,813	1,663,082	42.2%	493,269
TCPU	7,902,022	12,421,267	57.2%	4,519,245
Whole	371,299	805,376	116.9%	434,077
Retail	91,052,068	159,825,313	75.5%	68,773,245
FIRE	3,842,681	4,387,668	14.2%	544,987
Service	13,945,959	18,364,346	31.7%	4,418,387
Govt	7,491	20,979	180.1%	13,488
Total	119,702,481	200,044,811	67.1%	80,342,330

Table 6.17

Soldotna Annual TAXABLE Sales One Year Change by INDUSTRY - 2003 v. 2004 - in \$				
			1 Year Change	
	2003	2004	Percentage	Numerical
AFF	1,176,634	1,123,088	-4.6%	-53,546
Min	33,067	20,326	0.0%	-12,741
Const	1,588,752	1,413,366	-11.0%	-175,386
Manu	1,674,325	1,663,082	-0.7%	-11,243
TCPU	12,295,182	12,421,267	1.0%	126,085
Whole	997,320	805,376	-19.2%	-191,944
Retail	151,124,891	159,825,313	5.8%	8,700,422
FIRE	4,480,551	4,387,668	-2.1%	-92,883
Service	17,208,443	18,364,346	6.7%	1,155,903
Govt	41,717	20,979	-49.7%	-20,738
Total	190,620,882	200,044,811	4.9%	9,423,929

Table 6.18

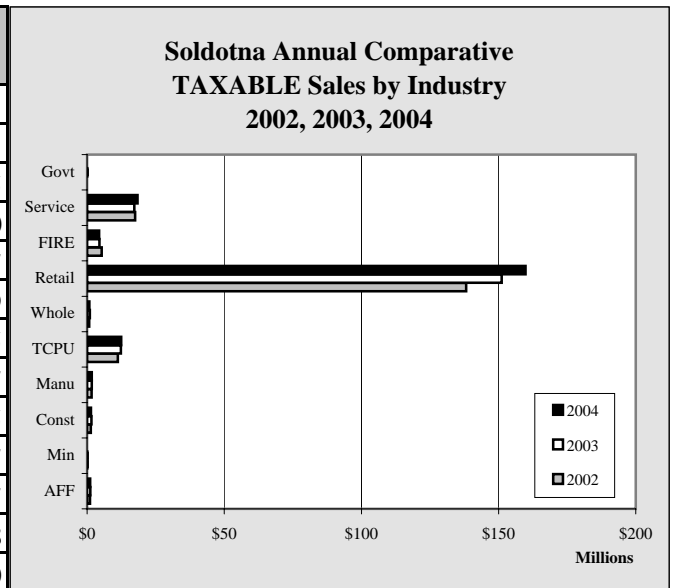

Chart 6.11

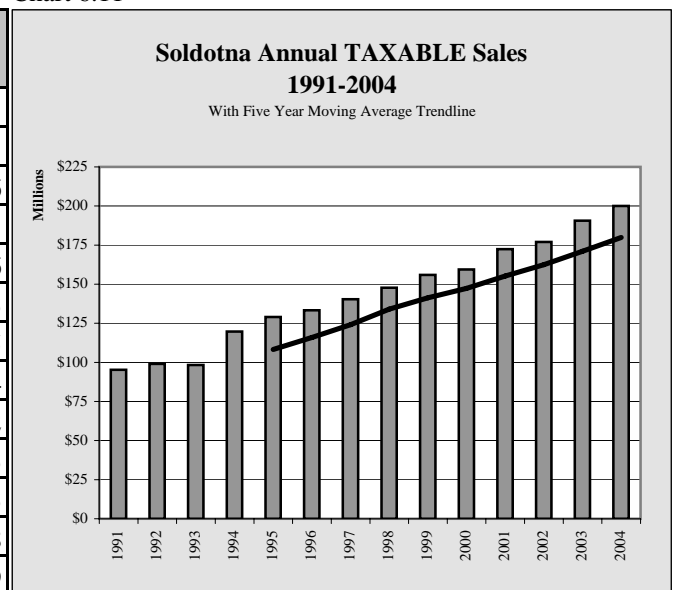

Chart 6.12

Soldotna Sales

Soldotna GROSS Sales by Industry by Quarter - 2002-2005 - in \$					
	1st Quarter	2nd Quarter	3rd Quarter	4th Quarter	Total
2002					
AFF	231,354	493,143	667,821	461,273	1,853,591
Min	98,101	106,949	86,164	119,470	410,684
Const	3,228,042	4,934,965	8,313,280	5,990,804	22,467,091
Manu	900,894	1,727,614	2,352,093	1,321,057	6,301,658
TCPU	3,685,725	3,531,451	4,900,494	3,782,935	15,900,605
Whole	8,072,050	7,353,520	12,524,522	12,251,677	40,201,769
Retail	36,487,247	49,060,629	60,884,442	45,511,862	191,944,180
FIRE	2,258,203	2,983,720	2,591,812	2,632,224	10,465,959
Service	7,363,434	9,561,798	11,299,921	8,105,750	36,330,903
Govt	6,700	7,859	4,290	3,730	22,579
Total	62,331,750	79,761,648	103,624,839	80,180,782	325,899,019
2003					
AFF	287,421	558,058	920,446	757,548	2,523,473
Min	110,629	122,012	99,139	118,724	450,504
Const	3,997,918	3,954,148	6,733,409	6,125,732	20,811,207
Manu	1,129,391	2,288,148	2,843,498	1,468,244	7,729,281
TCPU	4,211,327	3,827,252	3,716,921	4,587,100	16,342,600
Whole	7,309,289	9,554,591	10,562,562	6,942,427	34,368,869
Retail	36,780,913	52,177,533	65,995,934	49,743,210	204,697,590
FIRE	2,468,086	2,559,936	2,839,072	2,912,243	10,779,337
Service	7,947,659	10,170,868	12,543,766	9,491,364	40,153,657
Govt	12,319	8,680	12,192	8,526	41,717
Total	64,254,952	85,221,226	106,266,939	82,155,118	337,898,235
2004					
AFF	556,985	645,572	1,043,046	977,613	3,223,216
Min	92,181	154,892	136,149	165,250	548,472
Const	2,956,273	5,879,390	9,248,884	9,678,664	27,763,211
Manu	543,783	1,132,457	1,857,842	803,958	4,338,040
TCPU	4,796,956	4,716,238	5,692,042	5,016,710	20,221,946
Whole	9,720,151	8,967,548	3,326,912	6,755,499	28,770,110
Retail	39,606,915	54,022,404	70,283,879	53,719,465	217,632,663
FIRE	3,033,491	2,957,541	2,839,045	3,070,928	11,901,005
Service	8,614,515	10,824,252	12,762,242	14,622,362	46,823,371
Govt	6,904	8,521	2,880	2,674	20,979
Total	69,928,154	89,308,815	107,192,921	94,813,123	361,243,013
2005					
					Year to Date
AFF	578,453	1,029,914	1,238,356		2,846,723
Min	90,039	185,929	229,355		505,323
Const	4,633,293	5,045,071	9,599,552		19,277,916
Manu	513,748	1,374,104	2,001,565		3,889,417
TCPU	5,395,993	5,399,249	5,432,771		16,228,013
Whole	2,090,723	3,051,398	3,754,246		8,896,367
Retail	40,906,060	57,456,232	74,563,370		172,925,662
FIRE	2,801,299	3,068,056	2,906,572		8,775,927
Service	8,960,293	10,981,047	13,345,399		33,286,739
Govt	1,897	8,502	11,907		22,306
Total	65,971,798	87,599,502	113,083,093		266,654,393

Table 6.19

Soldotna Sales

Soldotna TAXABLE Sales by Industry by Quarter - 2002-2005 - in \$					
	1st Quarter	2nd Quarter	3rd Quarter	4th Quarter	Total
2002					
AFF	185,252	286,565	393,521	178,474	1,043,812
Min	6,447	7,414	7,836	11,581	33,278
Const	283,099	329,803	369,398	335,538	1,317,838
Manu	181,486	429,327	710,329	314,430	1,635,572
TCPU	2,752,273	2,619,156	2,944,886	2,861,745	11,178,060
Whole	135,437	231,064	251,226	145,509	763,236
Retail	25,570,526	33,723,015	45,546,360	33,338,606	138,178,507
FIRE	1,170,633	1,266,667	1,502,411	1,339,492	5,279,203
Service	3,444,755	4,603,064	5,758,366	3,719,598	17,525,783
Govt	6,700	7,859	4,290	3,730	22,579
Total	33,736,608	43,503,934	57,488,623	42,248,703	176,977,868
2003					
AFF	167,593	297,426	457,868	253,747	1,176,634
Min	9,374	7,401	7,885	8,407	33,067
Const	301,760	430,437	464,677	391,878	1,588,752
Manu	219,705	436,364	739,665	278,591	1,674,325
TCPU	3,219,035	2,964,183	2,959,644	3,152,320	12,295,182
Whole	173,053	288,627	339,309	196,331	997,320
Retail	25,762,586	36,964,223	50,726,050	37,672,032	151,124,891
FIRE	1,148,207	1,163,695	1,176,522	992,127	4,480,551
Service	3,450,490	4,458,613	5,694,959	3,604,381	17,208,443
Govt	12,319	8,680	12,192	8,526	41,717
Total	34,464,122	47,019,649	62,578,771	46,558,340	190,620,882
2004					
AFF	219,231	270,912	444,134	188,811	1,123,088
Min	6,675	5,828	3,030	4,793	20,326
Const	316,390	377,000	369,202	350,774	1,413,366
Manu	197,841	375,725	804,097	285,419	1,663,082
TCPU	3,338,198	2,985,335	2,949,371	3,148,363	12,421,267
Whole	154,053	254,535	263,334	133,454	805,376
Retail	28,539,627	38,706,949	53,989,889	38,588,848	159,825,313
FIRE	961,662	1,131,365	1,279,786	1,014,855	4,387,668
Service	3,643,247	4,894,259	6,072,228	3,754,612	18,364,346
Govt	6,904	8,521	2,880	2,674	20,979
Total	37,383,828	49,010,429	66,177,951	47,472,603	200,044,811
2005					
					Year to Date
AFF	180,695	265,254	486,480		932,429
Min	6,145	6,989	6,831		19,965
Const	336,069	407,449	391,911		1,135,429
Manu	189,774	405,938	754,317		1,350,029
TCPU	3,301,620	3,213,306	3,186,012		9,700,938
Whole	118,866	262,964	265,431		647,261
Retail	30,079,249	41,791,331	57,213,872		129,084,452
FIRE	964,417	1,090,393	1,179,694		3,234,504
Service	3,558,061	4,686,527	6,083,566		14,328,154
Govt	1,897	8,502	11,907		22,306
Total	38,736,793	52,138,653	69,580,021		160,455,467

Table 6.20

Soldotna Construction Permitting

Soldotna 3rd Quarter Permit VALUES by Type - 1999-2005 - in \$

	1999	2000	2001	2002	2003	2004	2005	Annual Change
Residential New	1,368,900	543,930	1,510,852	689,202	648,388	1,270,100	1,295,670	2.0%
Residential Alter/Add	141,867	101,065	50,148	317,466	70,722	145,721	88,410	-39.3%
Commercial New	2,495,816	935,665	630,244	1,080,678	1,371,200	21,996,101	1,520,000	-93.1%
Commercial Alter/Add	119,996	96,250	318,672	610,000	328,000	368,193	181,650	-50.7%
Total	4,126,579	1,676,910	2,509,916	2,697,346	2,418,310	23,780,115	3,085,730	-87.0%
Annual Change		-59.4%	49.7%	7.5%	-10.3%	883.3%	-87.0%	

Table 6.21

Soldotna 3rd Quarter Permit VALUES by Type - 1986-2005

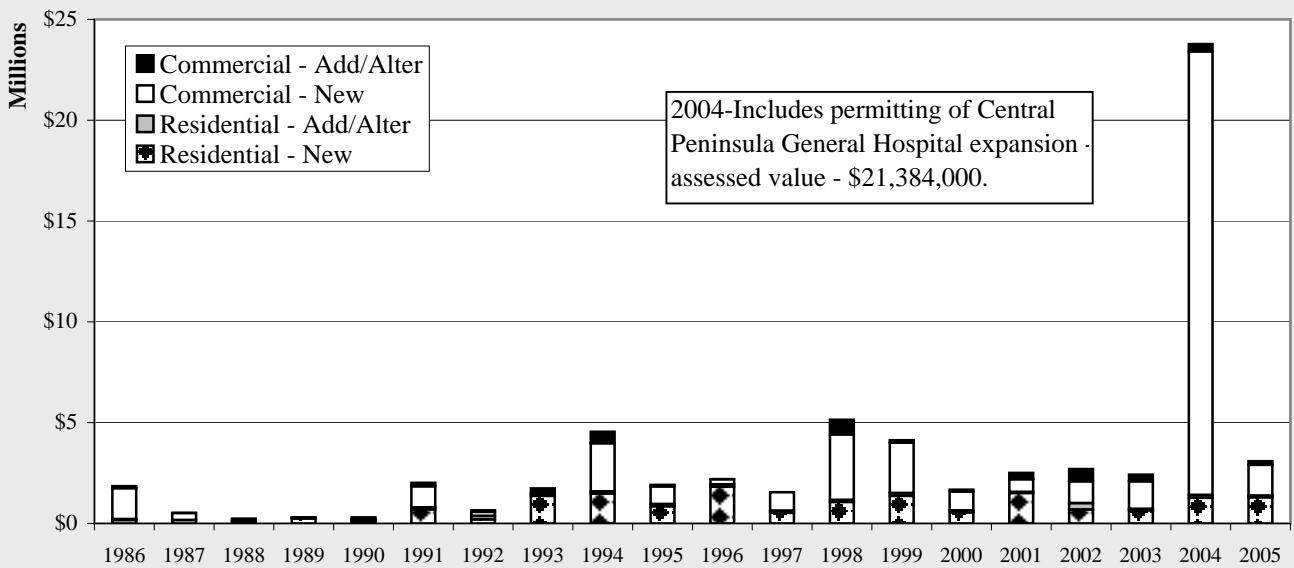

Chart 6.13

**Soldotna 3rd Quarter Permit VALUES
Percent by Type - 2005**

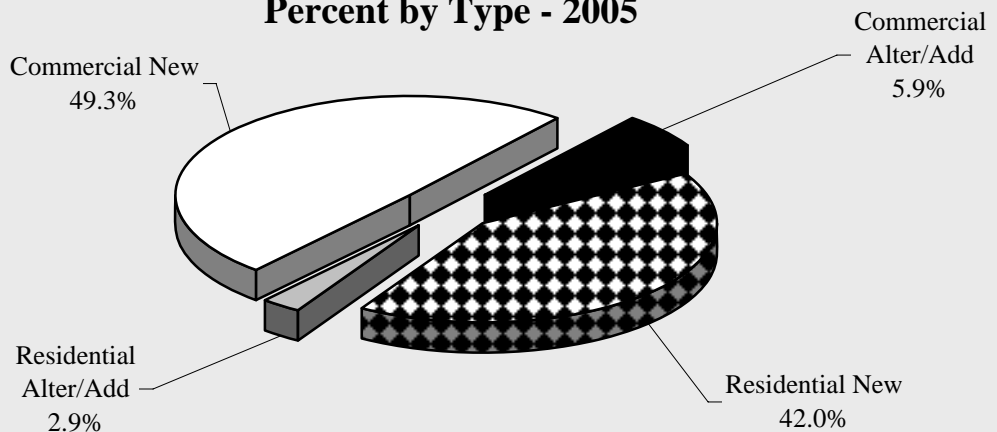

Chart 6.14

Soldotna Construction Permitting

Soldotna 3rd Quarter Permit VOLUME by Type - 1999-2005								
	1999	2000	2001	2002	2003	2004	2005	Annual Change
Residential New	7	5	10	5	4	7	7	0.0%
Residential Alter/Add	4	7	6	10	4	6	7	16.7%
Commercial New	6	7	7	5	8	4	2	-50.0%
Commercial Alter/Add	6	7	12	5	3	7	4	-42.9%
Total	23	26	35	25	19	24	20	-16.7%
Annual Change		13.0%	34.6%	-28.6%	-24.0%	26.3%	-16.7%	

Table 6.22

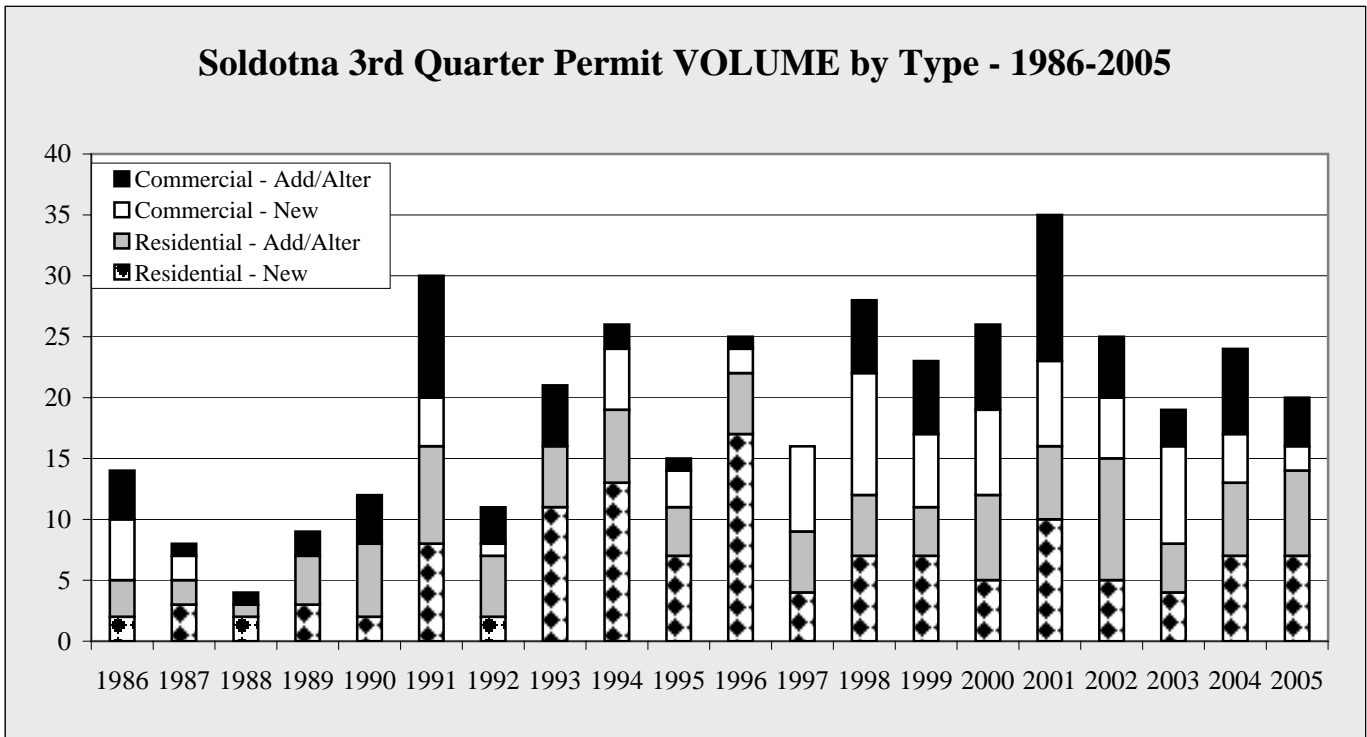

Chart 6.15

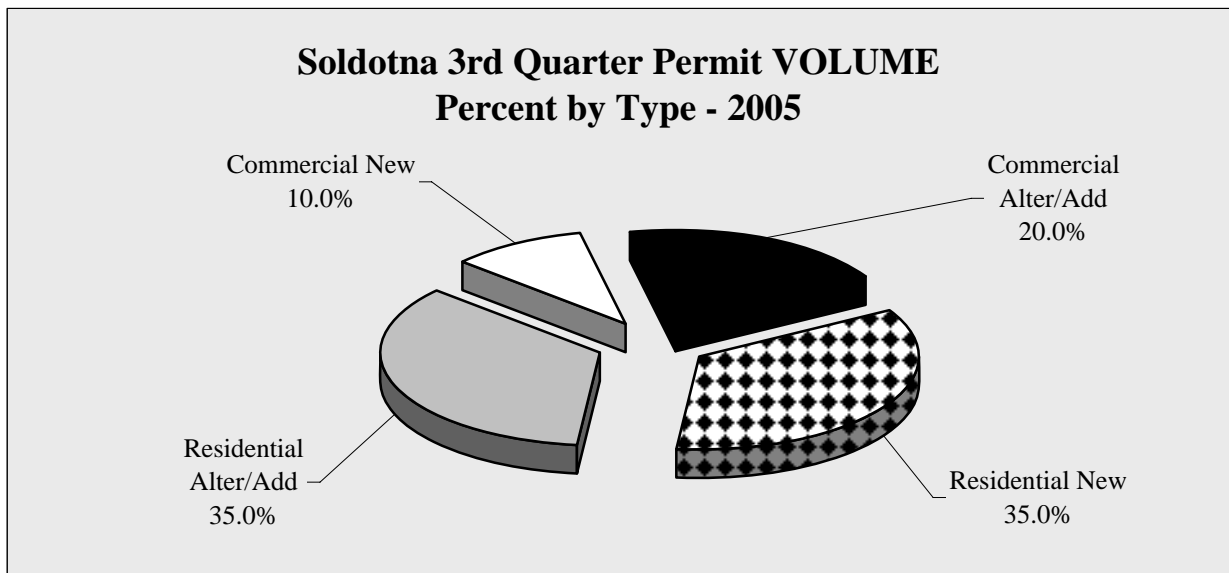

Chart 6.16

Soldotna Construction Permitting

Soldotna YTD 9/30 Permit VALUES by Type - 1999-2005 - in \$								
	1999	2000	2001	2002	2003	2004	2005	Annual Change
Residential New	2,822,574	2,438,350	3,873,853	3,005,344	2,547,742	3,586,484	3,933,625	9.7%
Residential Alter/Add	377,228	325,739	306,347	743,687	258,629	220,530	491,990	123.1%
Commercial New	5,219,634	2,953,580	3,288,822	4,397,059	3,487,690	27,827,424	5,814,828	-79.1%
Commercial Alter/Add	575,891	1,046,799	1,323,302	2,760,304	785,191	958,573	1,099,077	14.7%
Total	8,995,327	6,764,468	8,792,324	10,906,394	7,079,252	32,593,011	11,339,520	-65.2%
Annual Change		-24.8%	30.0%	24.0%	-35.1%	360.4%	-65.2%	

Table 6.23

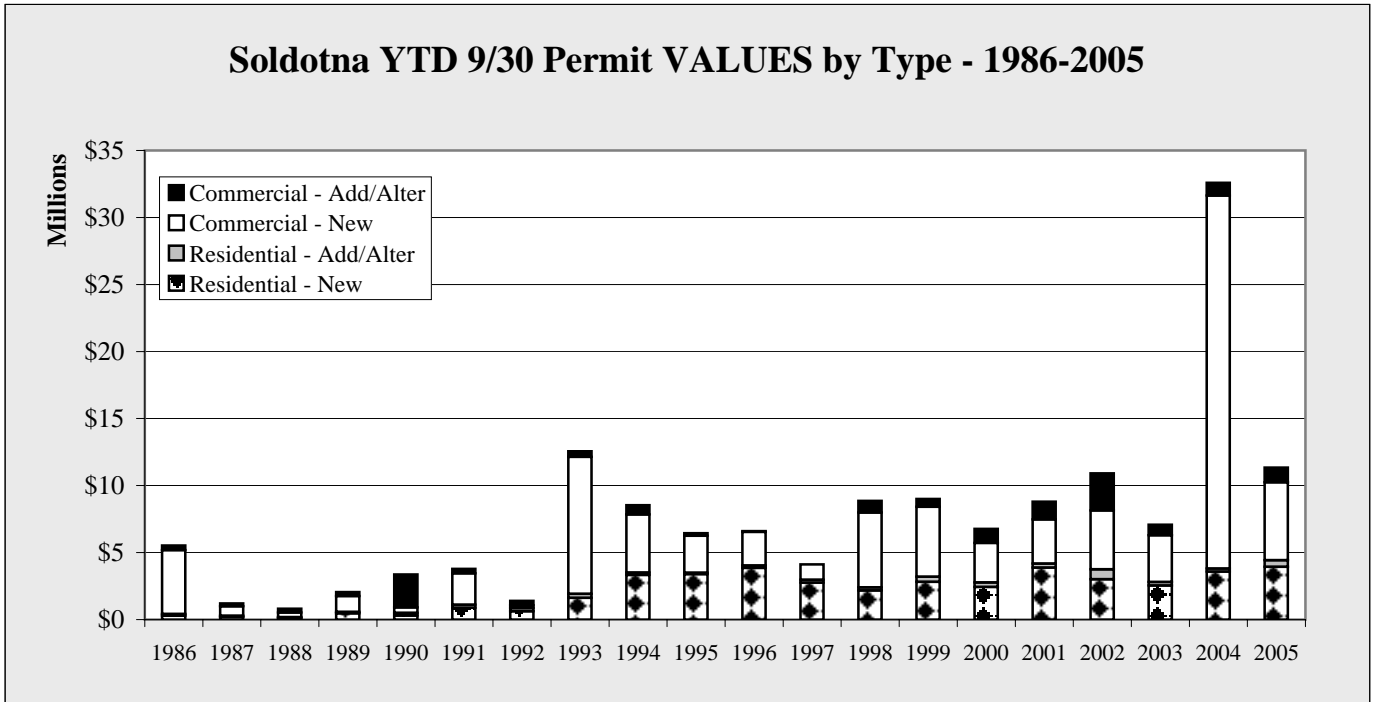

Chart 6.17

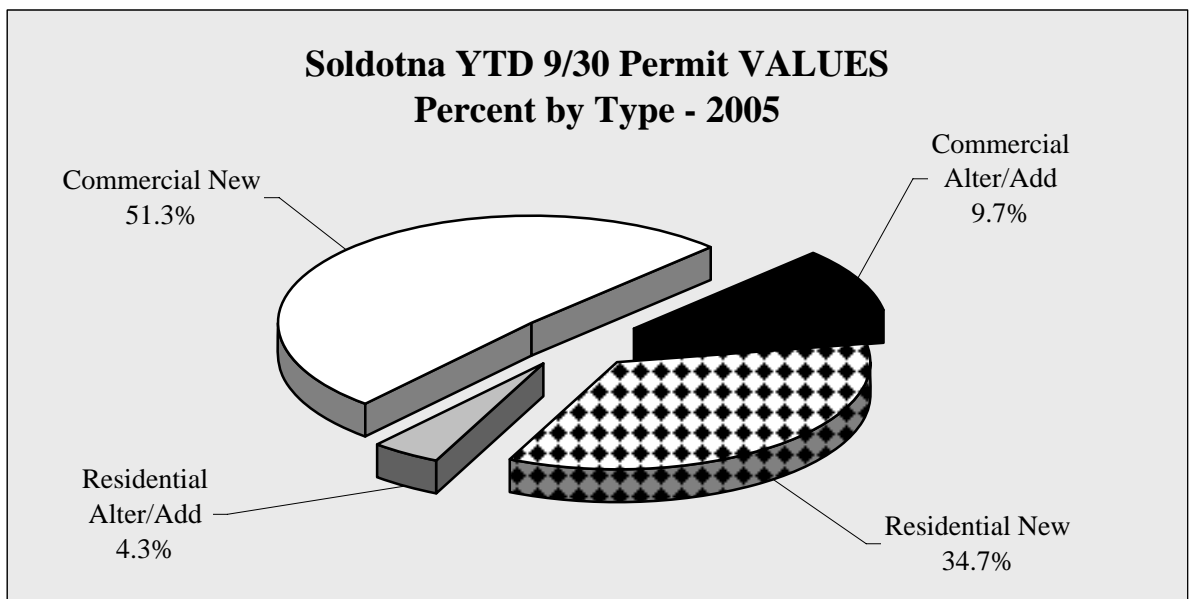

Chart 6.18

Soldotna Construction Permitting

Soldotna YTD 9/30 Permit VOLUME by Type - 1999-2005								
	1999	2000	2001	2002	2003	2004	2005	Annual Change
Residential New	17	17	24	23	19	18	22	22.2%
Residential Alter/Add	16	16	19	18	15	14	22	57.1%
Commercial New	14	11	10	18	14	11	13	18.2%
Commercial Alter/Add	21	24	29	28	13	16	19	18.8%
Total	68	68	82	87	61	59	76	28.8%
Annual Change		0.0%	20.6%	6.1%	-29.9%	-3.3%	28.8%	

Table 6.24

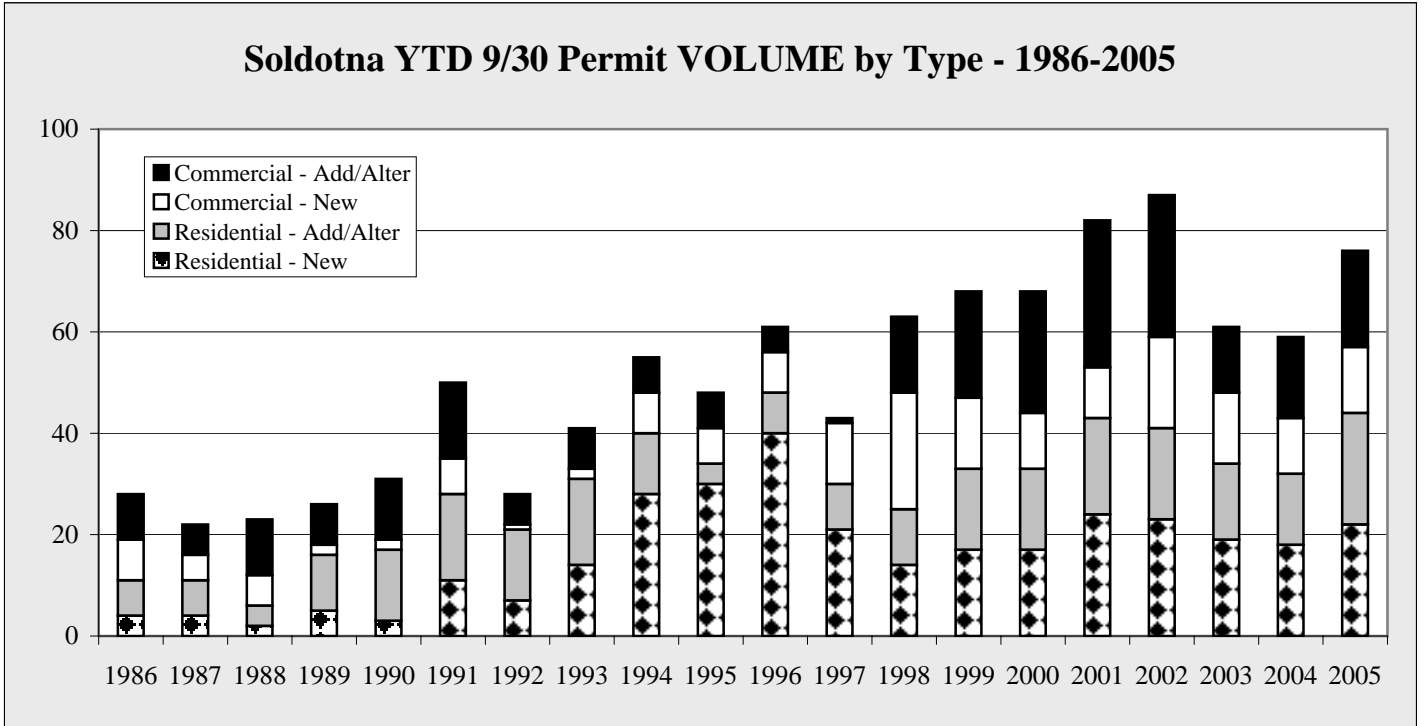

Chart 6.19

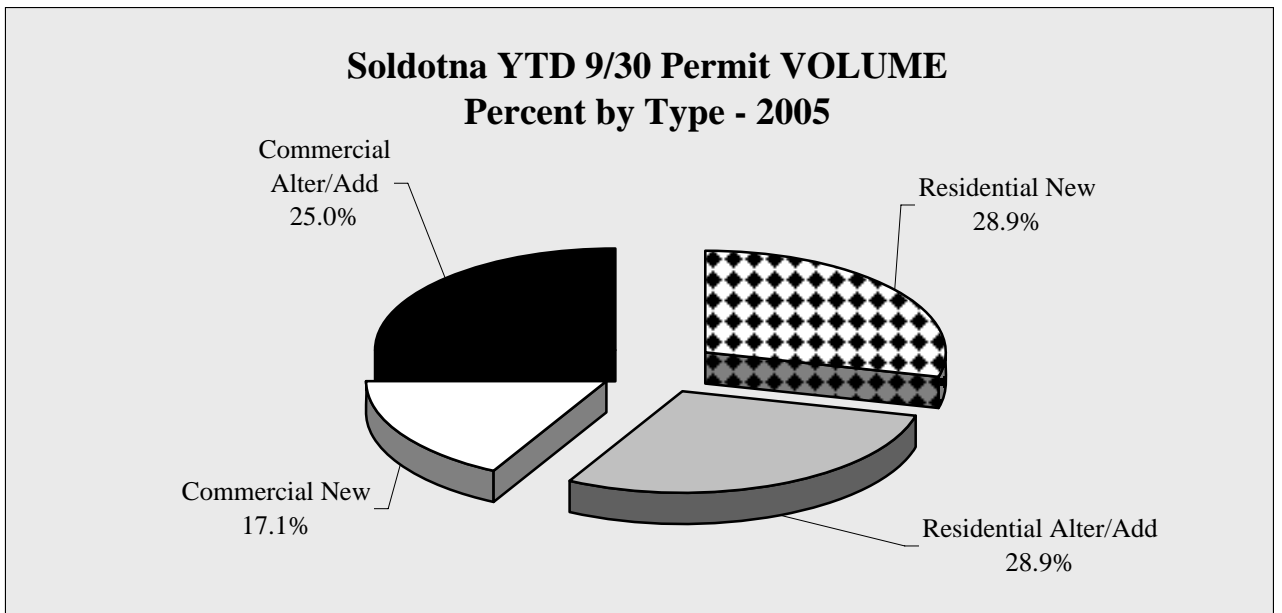

Chart 6.20

Soldotna Construction Permitting

Soldotna Annual Permit VALUES by Type - 1998-2004 - in \$								
	1998	1999	2000	2001	2002	2003	2004	Annual Change
Residential New	2,347,000	3,048,462	2,709,018	3,873,853	3,181,344	3,073,933	3,881,344	26.3%
Residential Alter/Add	237,060	377,228	365,239	357,495	755,187	263,629	277,984	5.4%
Commercial New	5,890,665	5,501,539	3,924,064	3,288,822	4,397,059	3,769,181	28,329,025	651.6%
Commercial Alter/Add	1,147,092	577,891	1,169,099	1,434,802	2,830,304	845,554	4,808,573	468.7%
Total	9,621,817	9,505,120	8,167,420	8,954,972	11,163,894	7,952,297	37,296,926	369.0%
Annual Change		-1.2%	-14.1%	9.6%	24.7%	-28.8%	369.0%	

Table 6.25

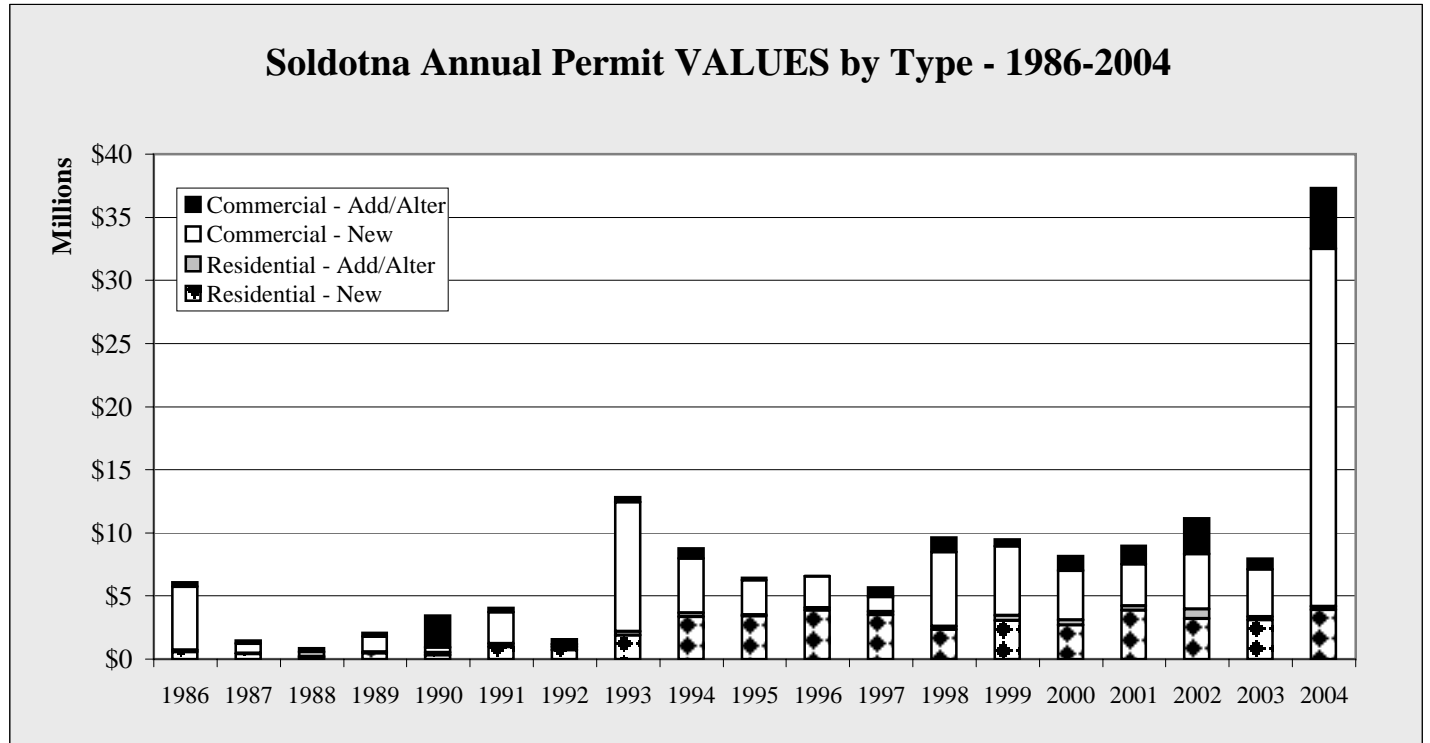

Chart 6.21

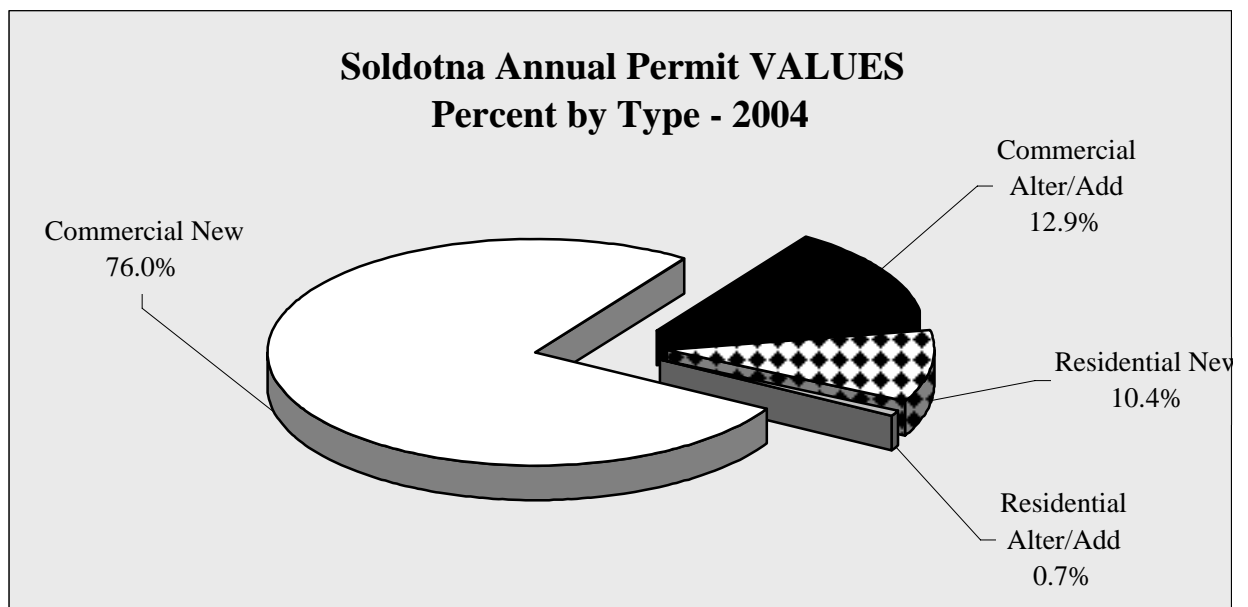

Chart 6.22

Soldotna Construction Permitting

Soldotna Annual Permit VOLUME by Type - 1998-2004

	1998	1999	2000	2001	2002	2003	2004	Annual Change
Residential New	15	19	19	24	24	24	19	-20.8%
Residential Alter/Add	16	16	19	23	20	16	17	6.3%
Commercial New	25	20	18	10	18	16	13	-18.8%
Commercial Alter/Add	21	22	32	36	29	18	18	0.0%
Total	77	77	88	93	91	74	67	-9.5%
Annual Change		0.0%	14.3%	5.7%	-2.2%	-18.7%	-9.5%	

Table 6.26

Soldotna Annual Permit VOLUME by Type - 1986-2004

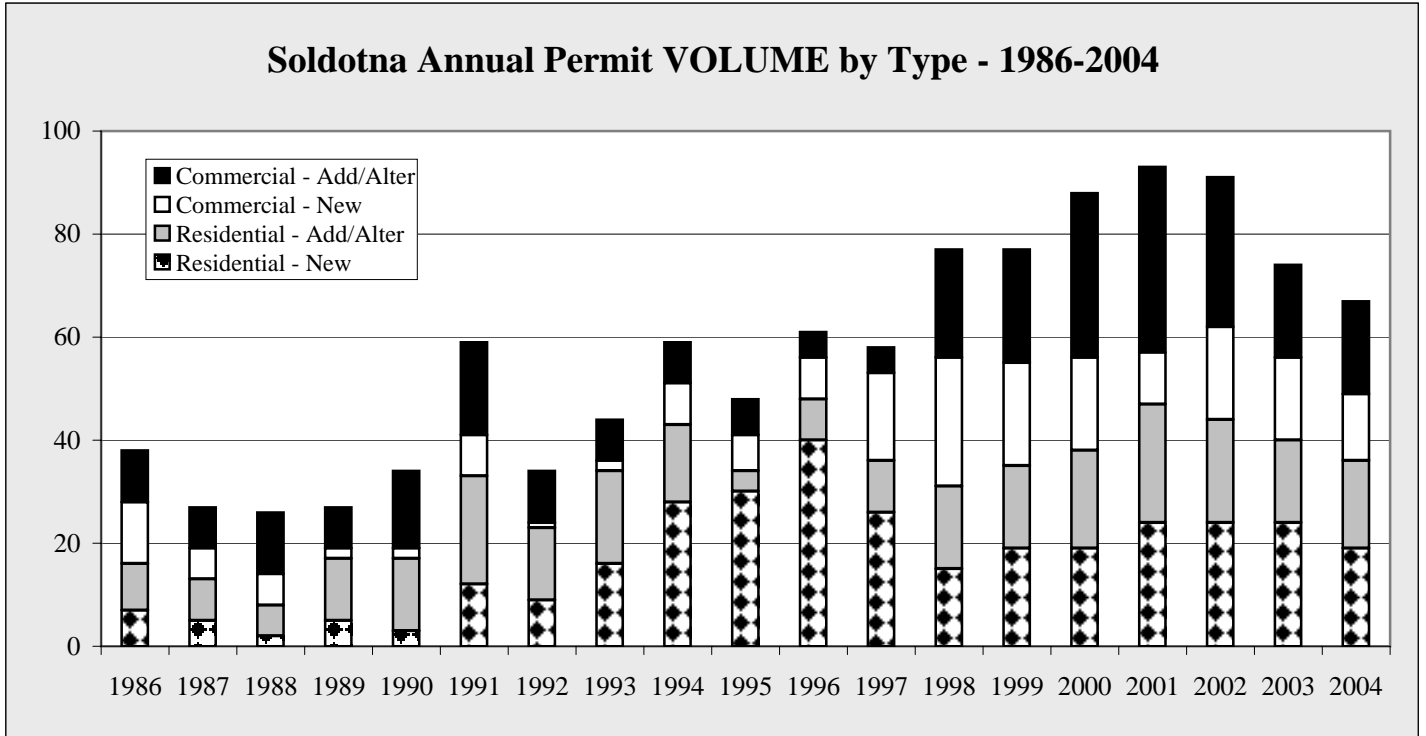

Chart 6.23

**Soldotna Annual Permit VOLUME
Percent by Type - 2004**

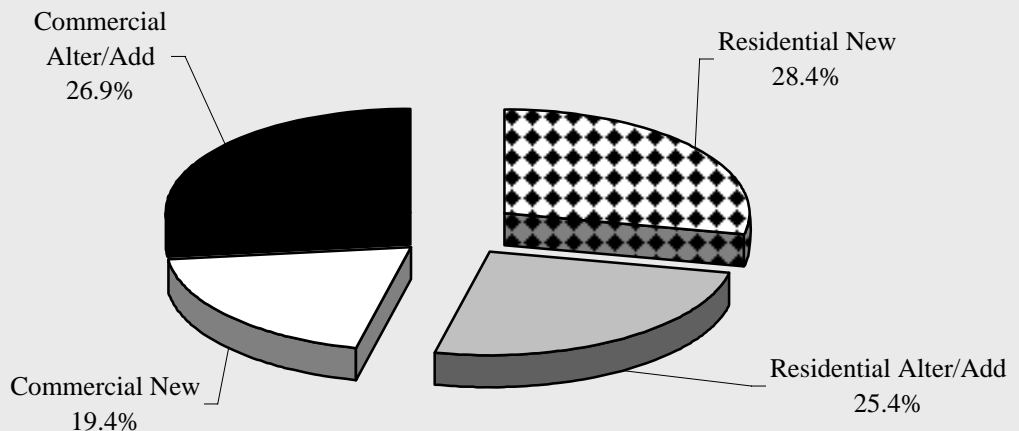

Chart 6.24

Soldotna Construction Permitting

Soldotna Annual Permit VALUES by Type by Quarter - 1998-2005 - in \$					
	1st Quarter	2nd Quarter	3rd Quarter	4th Quarter	Total
1998					
Residential - New	145,000	965,000	1,062,000	175,000	2,347,000
Residential - Add/Alter	0	122,000	103,400	11,660	237,060
Commercial - New	6,552	2,333,400	3,250,713	300,000	5,890,665
Commercial - Add/Alter	78,542	73,000	723,050	272,500	1,147,092
TOTAL	230,094	3,493,400	5,139,163	759,160	9,621,817
1999					
Residential - New	0	1,453,674	1,368,900	225,888	3,048,462
Residential - Add/Alter	54,000	181,361	141,867	0	377,228
Commercial - New	0	2,723,818	2,495,816	281,905	5,501,539
Commercial - Add/Alter	29,696	426,199	119,996	2,000	577,891
TOTAL	83,696	4,785,052	4,126,579	509,793	9,505,120
2000					
Residential - New	373,929	1,520,491	543,930	270,668	2,709,018
Residential - Add/Alter	0	224,674	101,065	39,500	365,239
Commercial - New	434,273	1,583,642	935,665	970,484	3,924,064
Commercial - Add/Alter	270,000	680,549	96,250	122,300	1,169,099
TOTAL	1,078,202	4,009,356	1,676,910	1,402,952	8,167,420
2001					
Residential - New	0	2,363,001	1,510,852	0	3,873,853
Residential - Add/Alter	105,160	151,039	50,148	51,148	357,495
Commercial - New	2,658,578	0	630,244	0	3,288,822
Commercial - Add/Alter	287,480	717,150	318,672	111,500	1,434,802
TOTAL	3,051,218	3,231,190	2,509,916	162,648	8,954,972
2002					
Residential - New	240,849	2,075,293	689,202	176,000	3,181,344
Residential - Add/Alter	86,935	339,286	317,466	11,500	755,187
Commercial - New	714,806	2,601,575	1,080,678	0	4,397,059
Commercial - Add/Alter	163,000	1,987,304	610,000	70,000	2,830,304
TOTAL	1,205,590	7,003,458	2,697,346	257,500	11,163,894
2003					
Residential - New	0	1,899,354	648,388	526,191	3,073,933
Residential - Add/Alter	57,827	130,080	70,722	5,000	263,629
Commercial - New	0	2,116,490	1,371,200	281,491	3,769,181
Commercial - Add/Alter	369,191	88,000	328,000	60,363	845,554
TOTAL	427,018	4,233,924	2,418,310	873,045	7,952,297
2004					
Residential - New	539,297	1,777,087	1,270,100	294,860	3,881,344
Residential - Add/Alter	0	74,809	145,721	57,454	277,984
Commercial - New	4,465,026	1,366,297	21,996,101	501,601	28,329,025
Commercial - Add/Alter	60,000	530,380	368,193	3,850,000	4,808,573
TOTAL	5,064,323	3,748,573	23,780,115	4,703,915	37,296,926
2005					
Residential - New	720,956	1,916,999	1,295,670		3,933,625
Residential - Add/Alter	261,630	141,950	88,410		491,990
Commercial - New	195,000	4,099,828	1,520,000		5,814,828
Commercial - Add/Alter	243,969	673,458	181,650		1,099,077
TOTAL	1,421,555	6,832,235	3,085,730		11,339,520
					Year to Date

Table 6.27

Soldotna Construction Permitting

Soldotna Annual Permit VOLUME by Type by Quarter - 1998-2005					
	1st Quarter	2nd Quarter	3rd Quarter	4th Quarter	Total
1998					
Residential - New	1	6	7	1	15
Residential - Add/Alter	0	6	5	5	16
Commercial - New	2	11	10	2	25
Commercial - Add/Alter	5	4	6	6	21
TOTAL	8	27	28	14	77
1999					
Residential - New	0	10	7	2	19
Residential - Add/Alter	4	8	4	0	16
Commercial - New	0	8	6	6	20
Commercial - Add/Alter	6	9	6	1	22
TOTAL	10	35	23	9	77
2000					
Residential - New	2	10	5	2	19
Residential - Add/Alter	0	9	7	3	19
Commercial - New	1	3	7	7	18
Commercial - Add/Alter	5	12	7	8	32
TOTAL	8	34	26	20	88
2001					
Residential - New	0	14	10	0	24
Residential - Add/Alter	3	10	6	4	23
Commercial - New	3	0	7	0	10
Commercial - Add/Alter	4	13	12	7	36
TOTAL	10	37	35	11	93
2002					
Residential - New	1	17	5	1	24
Residential - Add/Alter	2	6	10	2	20
Commercial - New	4	9	5	0	18
Commercial - Add/Alter	4	19	5	1	29
TOTAL	11	51	25	4	91
2003					
Residential - New	0	15	4	5	24
Residential - Add/Alter	3	8	4	1	16
Commercial - New	0	6	8	2	16
Commercial - Add/Alter	3	7	3	5	18
TOTAL	6	36	19	13	74
2004					
Residential - New	2	9	7	1	19
Residential - Add/Alter	0	8	6	3	17
Commercial - New	4	3	4	2	13
Commercial - Add/Alter	3	6	7	2	18
TOTAL	9	26	24	8	67
2005					Year to Date
Residential - New	4	11	7		22
Residential - Add/Alter	3	12	7		22
Commercial - New	2	9	2		13
Commercial - Add/Alter	7	8	4		19
TOTAL	16	40	20		76

Table 6.28

Soldotna Cost of Food

Cost of food data is collected by the University of Alaska, Fairbanks Cooperative Extension. Each quarter the Cooperative Extension surveys up to three grocers in communities throughout the state to determine the cost of food for one week. Specific guidelines are presented to the surveyors regarding item size and sale price for 104 items. Because separation of Kenai and Soldotna data would be meaningless, data presented relates to both communities.

SOLDOTNA/KENAI											
	Sept 1996	Sept 1997	Sept 1998	Sept 1999	Sept 2000	Sept 2001	Sept 2002	Sept 2003	Sept 2004	Sept 2005	Annual Change
Sales Tax (in percent)	5.0	5.0	5.0	5.0	5.0	5.0	5.0	5.0	5.0	5.0	
Percent of Food Unavailable	0.0	0.0	0.0	0.0	1.0	1.0	1.0	0.0	0.0	0.0	
Child, 1 year	15.8	15.7	15.5	16.4	16.6	17.8	17.6	18.3	19.0	19.1	0.2%
Child, 2 years	0.0	0.0	0.0	0.0	0.0	17.8	17.6	18.3	18.8	18.4	-2.5%
Children 3-5 years of age	17.3	17.2	17.0	18.0	18.3	19.6	19.4	20.0	20.8	20.8	-0.1%
Children 6-8 years of age	22.9	22.8	22.6	23.9	24.3	26.0	25.9	26.7	27.8	28.0	0.6%
Children 9-11 years of age	26.0	25.9	25.7	27.1	27.6	29.5	29.4	30.2	31.4	31.5	0.5%
Males 12-14 years of age	29.4	29.2	29.0	30.6	31.3	33.4	33.2	34.1	35.5	35.6	0.5%
Males 15-19 years of age	30.3	30.2	29.9	31.5	32.2	34.4	34.2	35.1	36.4	36.7	0.8%
Males 20-50 years of age	29.9	29.9	29.8	31.3	32.1	34.3	34.1	35.0	36.5	36.7	0.5%
Males 51 and older	28.5	28.6	28.4	29.8	30.5	32.5	32.5	33.4	34.7	34.8	0.3%
Females 12-19 years of age	25.3	25.2	25.0	26.3	26.9	28.8	28.5	29.4	30.5	30.7	0.6%
Females 20-50 years of age	26.2	26.3	26.1	27.3	28.0	29.8	29.8	30.5	31.8	31.9	0.4%
Females 51 and older	25.4	25.4	25.2	26.6	27.2	29.0	28.9	29.6	30.9	31.0	0.3%
Family of 2, 20-50 years of age	61.7	61.8	61.5	64.4	66.1	70.5	70.3	72.1	75.1	75.4	0.5%
Family of 2, 51 years and older	59.3	59.5	59.0	62.0	63.4	67.6	67.5	69.3	72.2	72.4	0.3%
Family of 4, children 1-5 years	89.2	89.1	88.4	93.0	95.0	101.4	100.9	103.6	107.9	108.2	0.3%
Family of 4, children 6-11 years	105.0	104.9	104.1	109.6	112.0	119.6	119.1	122.4	127.4	128.1	0.5%
Electricity, 1000 kWh	111.0	111.0	120.7	119.3	113.2	122.1	126.2	113.8	121.4	135.1	11.3%
Gasoline, auto, 55 gal	72.6	75.9	76.2	78.7	93.8	93.8	87.5	103.7	115.5	156.2	35.2%
Lumber, 2X4X8'	4.0	3.5	3.3	3.5	3.3	3.5	3.3	3.4	3.5	3.0	-16.7%
Propane, 100 lb. refill	38.2	39.5	38.7	34.9	41.8	0.0	43.4	48.1	51.9	59.0	13.6%
Sewer & Water, monthly	41.3	41.3	41.3								

Table 6.29

Soldotna Cost of Food

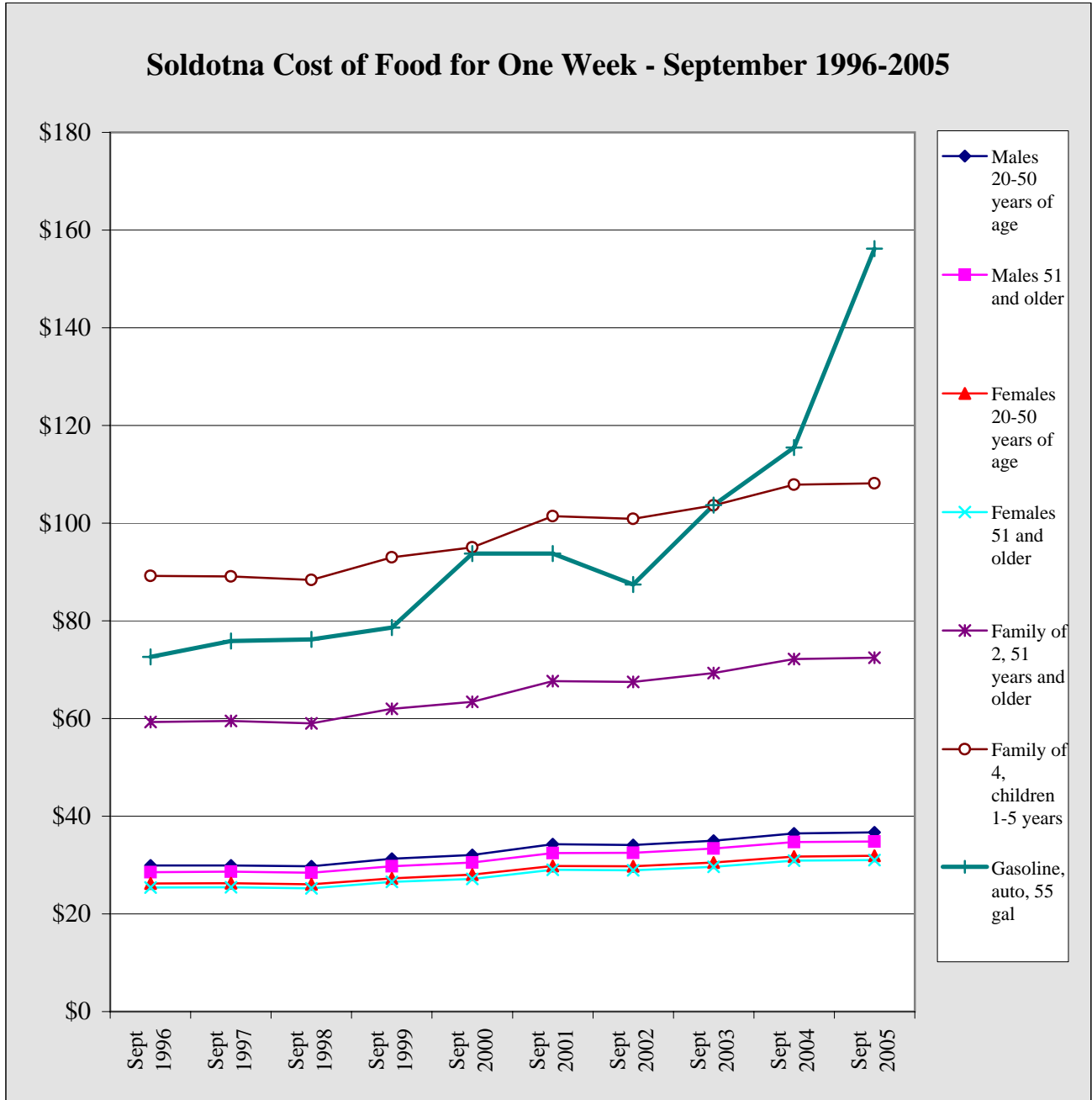

Chart 6.25

Other KPB Sales

Other KPB 3rd Quarter GROSS Sales by Industry - 1999-2005 - in \$

	1999	2000	2001	2002	2003	2004	2005
AFF	966,889	1,029,146	953,930	1,430,097	1,578,920	1,632,207	1,174,400
Min	22,169,207	35,218,990	34,663,461	25,287,979	28,701,184	36,588,670	42,053,583
Const	31,680,108	30,253,103	49,545,609	40,528,297	44,783,625	37,203,422	36,475,346
Manu	48,723,141	23,197,166	53,466,153	44,941,727	53,343,537	87,311,541	84,878,977
TCPU	21,633,345	17,756,039	23,161,349	21,630,289	18,568,068	20,217,590	22,628,374
Whole	26,663,588	32,145,891	32,718,508	31,837,444	37,077,443	36,327,578	23,067,251
Retail	41,051,496	44,221,827	46,562,223	50,013,715	52,439,119	54,327,215	55,141,163
FIRE	5,261,681	3,283,551	4,523,256	3,878,053	5,140,046	4,894,601	6,383,709
Service	34,572,553	38,368,683	40,794,309	43,193,240	42,294,496	48,091,816	48,288,262
Govt	0	0	0	0	0	6,304	0
Total	232,722,008	225,474,396	286,388,798	262,740,841	283,926,438	326,600,944	320,091,065
Annual Change		-3.1%	27.0%	-8.3%	8.1%	15.0%	-2.0%

Table 7.1

**Other KPB 3rd Quarter GROSS Sales Ten Year Change
by INDUSTRY - 1995 v. 2005 - in \$**

	10 Year Change			
	1995	2005	Percentage	Numerical
AFF	2,743,992	1,174,400	-57.2%	-1,569,592
Min	23,223,792	42,053,583	81.1%	18,829,791
Const	26,012,878	36,475,346	40.2%	10,462,468
Manu	42,015,097	84,878,977	102.0%	42,863,880
TCPU	51,054,649	22,628,374	-55.7%	-28,426,275
Whole	22,032,608	23,067,251	4.7%	1,034,643
Retail	36,273,914	55,141,163	52.0%	18,867,249
FIRE	3,853,864	6,383,709	65.6%	2,529,845
Service	25,835,078	48,288,262	86.9%	22,453,184
Govt	0	0	0.0%	0
Total	233,045,872	320,091,065	37.4%	87,045,193

Table 7.2

**Other KPB 3rd Quarter GROSS Sales One Year Change
by INDUSTRY - 2004 v. 2005 - in \$**

	1 Year Change			
	2004	2005	Percentage	Numerical
AFF	1,632,207	1,174,400	-28.0%	-457,807
Min	36,588,670	42,053,583	14.9%	5,464,913
Const	37,203,422	36,475,346	-2.0%	-728,076
Manu	87,311,541	84,878,977	-2.8%	-2,432,564
TCPU	20,217,590	22,628,374	11.9%	2,410,784
Whole	36,327,578	23,067,251	-36.5%	-13,260,327
Retail	54,327,215	55,141,163	1.5%	813,948
FIRE	4,894,601	6,383,709	30.4%	1,489,108
Service	48,091,816	48,288,262	0.4%	196,446
Govt	6,304	0	0.0%	-6,304
Total	326,600,944	320,091,065	-2.0%	-6,509,879

Table 7.3

**Other KPB 3rd Quarter Comparative GROSS
Sales by Industry
2003, 2004, 2005**

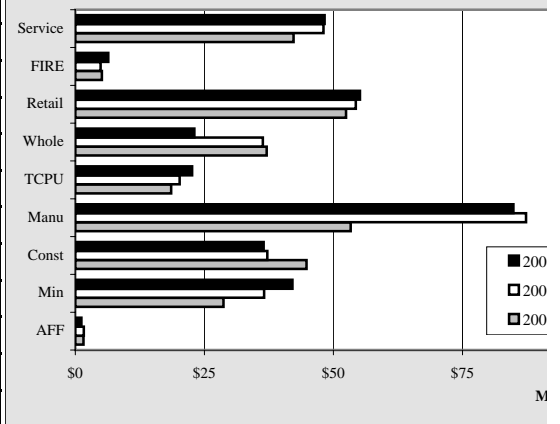

Chart 7.1

**Other KPB 3rd Quarter GROSS Sales
1991-2005
With Five Year Moving Average Trendline**

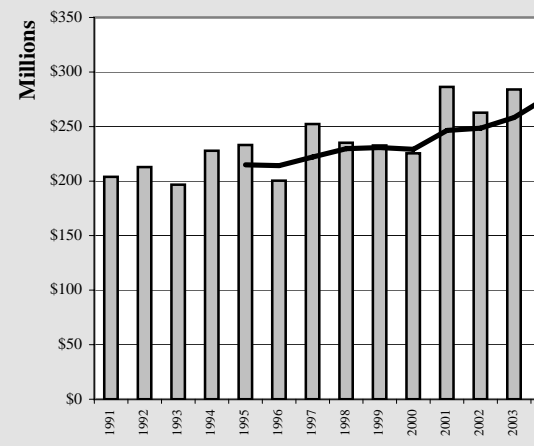
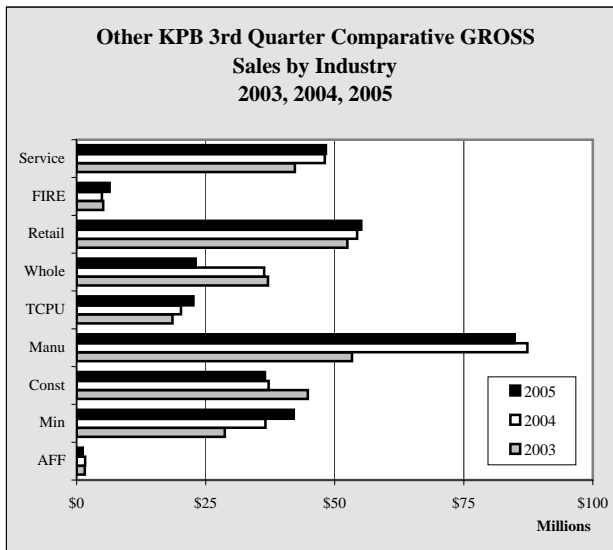

Chart 7.2

Other KPB Sales

Annual Change
-28.0%
14.9%
-2.0%
-2.8%
11.9%
-36.5%
1.5%
30.4%
0.4%
NA
-2.0%



Other KPB Sales

Other KPB 3rd Quarter TAXABLE Sales by Industry - 1999-2005 - in \$							
	1999	2000	2001	2002	2003	2004	2005
AFF	545,730	533,949	562,707	570,742	635,120	748,068	843,668
Min	985,754	1,304,855	1,615,441	1,489,849	1,252,874	1,829,645	1,021,670
Const	1,806,059	1,858,589	1,950,673	2,141,282	2,022,587	2,105,131	1,927,363
Manu	1,141,095	1,279,317	1,195,610	1,202,450	968,694	1,215,828	1,174,247
TCPU	9,487,733	9,722,373	10,305,758	9,075,340	8,687,138	10,037,127	11,449,010
Whole	2,470,788	2,946,874	2,946,600	2,958,254	3,197,783	3,238,122	3,486,340
Retail	23,771,634	26,062,972	26,983,528	27,810,124	28,917,038	29,291,355	30,166,816
FIRE	1,605,786	1,651,339	1,834,570	1,941,804	2,240,741	1,987,672	2,235,540
Service	19,498,755	21,112,657	21,462,477	21,829,387	22,072,245	25,111,882	25,442,718
Govt	0	0	0	0	0	6,304	0
Total	61,313,334	66,472,925	68,857,364	69,019,232	69,994,220	75,571,134	77,747,372
Annual Change		8.4%	3.6%	0.2%	1.4%	8.0%	2.9%

Table 7.4

Other KPB 3rd Quarter TAXABLE Sales Ten Year Change by INDUSTRY - 1995 v. 2005 - in \$				
			10 Year Change	
	1995	2005	Percentage	Numerical
AFF	474,084	843,668	78.0%	369,584
Min	1,125,446	1,021,670	-9.2%	-103,776
Const	1,634,142	1,927,363	17.9%	293,221
Manu	1,014,830	1,174,247	15.7%	159,417
TCPU	8,101,456	11,449,010	41.3%	3,347,554
Whole	2,723,047	3,486,340	28.0%	763,293
Retail	22,329,160	30,166,816	35.1%	7,837,656
FIRE	1,317,118	2,235,540	69.7%	918,422
Service	14,076,124	25,442,718	80.8%	11,366,594
Govt	0	0	0.0%	0
Total	52,795,407	77,747,372	47.3%	24,951,965

Table 7.5

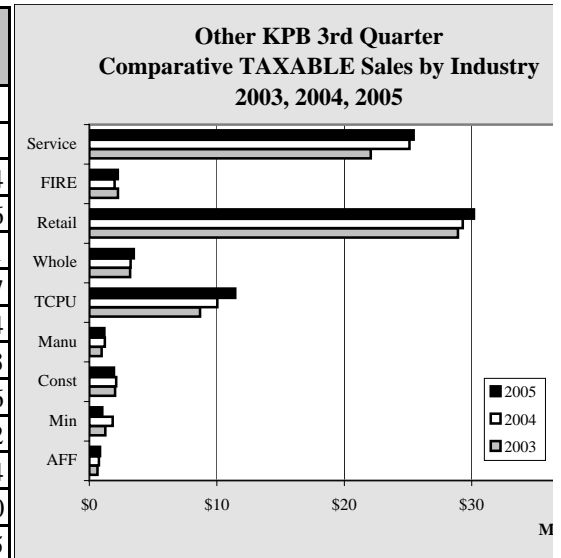

Chart 7.3

Other KPB 3rd Quarter TAXABLE Sales One Year Change by INDUSTRY - 2004 v. 2005 - in \$				
			1 Year Change	
	2004	2005	Percentage	Numerical
AFF	748,068	843,668	12.8%	95,600
Min	1,829,645	1,021,670	0.0%	-807,975
Const	2,105,131	1,927,363	-8.4%	-177,768
Manu	1,215,828	1,174,247	-3.4%	-41,581
TCPU	10,037,127	11,449,010	14.1%	1,411,883
Whole	3,238,122	3,486,340	7.7%	248,218
Retail	29,291,355	30,166,816	3.0%	875,461
FIRE	1,987,672	2,235,540	12.5%	247,868
Service	25,111,882	25,442,718	1.3%	330,836
Govt	6,304	0	0.0%	-6,304
Total	75,571,134	77,747,372	2.9%	2,176,238

Table 7.6

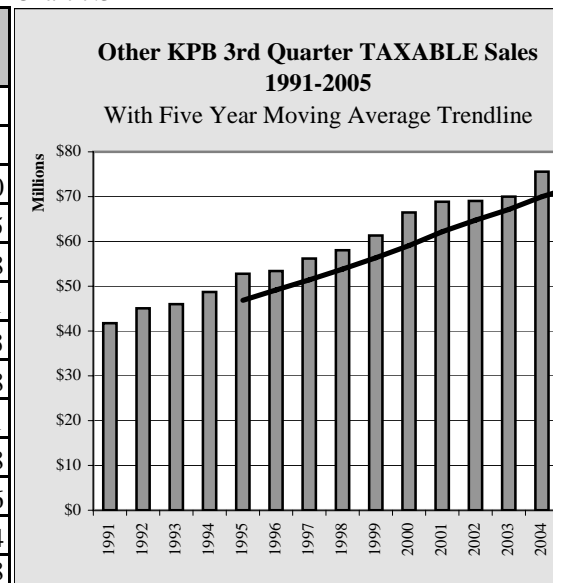
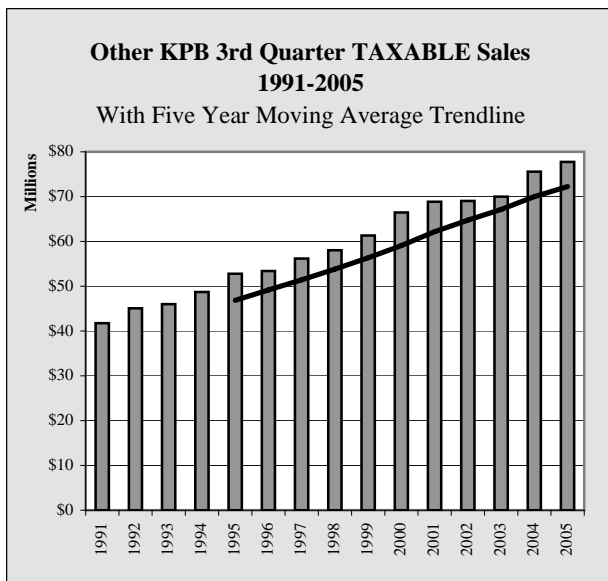
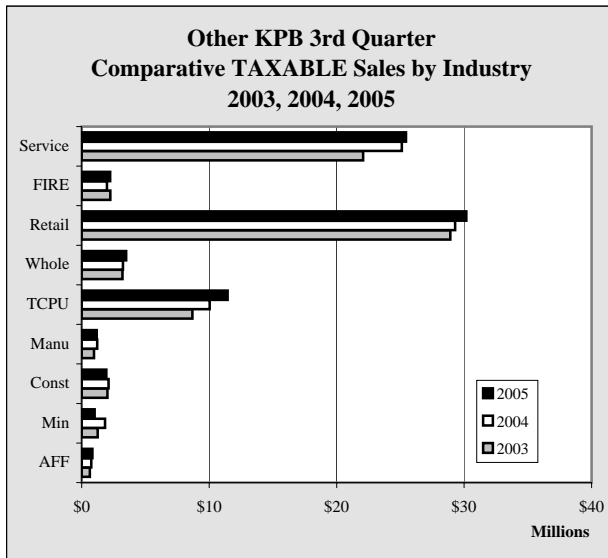

Chart 7.4

Other KPB Sales

Annual Change
12.8%
-44.2%
-8.4%
-3.4%
14.1%
7.7%
3.0%
12.5%
1.3%
NA
2.9%



Other KPB Sales

Other KPB YTD 9/30 GROSS Sales by Industry - 1999-2005 - in \$

	1999	2000	2001	2002	2003	2004	2005	Annual Change
AFF	2,325,314	2,276,761	2,632,573	3,020,240	4,066,236	3,326,654	3,193,729	-4.0%
Min	81,817,185	78,708,414	87,515,892	86,690,395	70,879,502	103,953,102	113,768,347	9.4%
Const	62,784,302	63,001,057	98,007,689	95,912,345	102,684,044	75,135,248	87,814,833	16.9%
Manu	97,867,159	69,556,929	140,850,244	94,767,550	107,056,261	116,861,240	165,550,656	41.7%
TCPU	58,446,196	48,880,308	57,011,966	58,218,992	48,800,999	51,899,057	60,603,003	16.8%
Whole	67,770,438	77,766,519	78,980,152	82,249,901	87,678,339	86,821,842	66,722,364	-23.2%
Retail	98,137,214	107,662,242	115,135,067	119,252,718	129,542,635	130,043,966	135,021,395	3.8%
FIRE	12,492,619	10,021,463	12,439,817	10,797,298	12,588,235	12,649,981	14,781,239	16.8%
Service	69,238,099	78,243,201	82,013,575	86,932,151	82,965,851	92,160,930	96,576,528	4.8%
Govt	0	0	0	0	0	12,669	13,317	NA
Total	550,878,526	536,116,894	674,586,975	637,841,590	646,262,102	672,864,689	744,045,411	10.6%
Annual Change		-2.7%	25.8%	-5.4%	1.3%	4.1%	10.6%	

Table 7.7

**Other KPB YTD 9/30 GROSS Sales Ten Year Change
by INDUSTRY - 1995 v. 2005 - in \$**

	1995	2005	10 Year Change	
			Percentage	Numerical
AFF	4,354,262	3,193,729	-26.7%	-1,160,533
Min	63,233,036	113,768,347	79.9%	50,535,311
Const	58,766,821	87,814,833	49.4%	29,048,012
Manu	92,700,677	165,550,656	78.6%	72,849,979
TCPU	119,520,035	60,603,003	-49.3%	-58,917,032
Whole	51,465,990	66,722,364	29.6%	15,256,374
Retail	87,533,743	135,021,395	54.3%	47,487,652
FIRE	10,232,562	14,781,239	44.5%	4,548,677
Service	51,502,904	96,576,528	87.5%	45,073,624
Govt	0	13,317	0.0%	13,317
Total	539,310,030	744,045,411	38.0%	204,735,381

Table 7.8

**Other KPB YTD 9/30 GROSS Sales One Year Change
by INDUSTRY - 2004 v. 2005 - in \$**

	2004	2005	1 Year Change	
			Percentage	Numerical
AFF	3,326,654	3,193,729	-4.0%	-132,925
Min	103,953,102	113,768,347	0.0%	9,815,245
Const	75,135,248	87,814,833	16.9%	12,679,585
Manu	116,861,240	165,550,656	41.7%	48,689,416
TCPU	51,899,057	60,603,003	16.8%	8,703,946
Whole	86,821,842	66,722,364	-23.2%	-20,099,478
Retail	130,043,966	135,021,395	3.8%	4,977,429
FIRE	12,649,981	14,781,239	16.8%	2,131,258
Service	92,160,930	96,576,528	4.8%	4,415,598
Govt	12,669	13,317	5.1%	648
Total	672,864,689	744,045,411	10.6%	71,180,722

Table 7.9

**Other KPB YTD 9/30
Comparative GROSS Sales by Industry
2003, 2004, 2005**

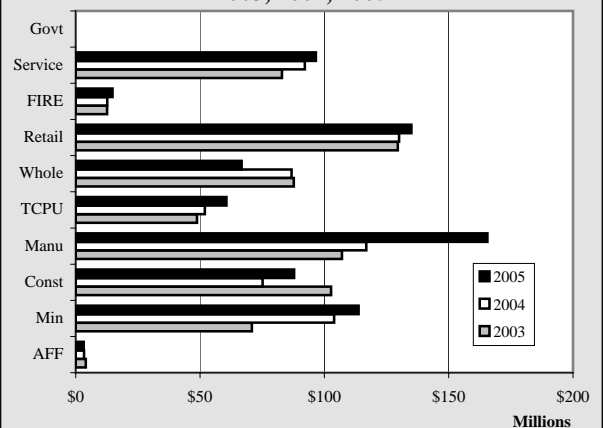

Chart 7.5

**Other KPB YTD 9/30
GROSS Sales - 1991-2005
With Five Year Moving Average Trendline**

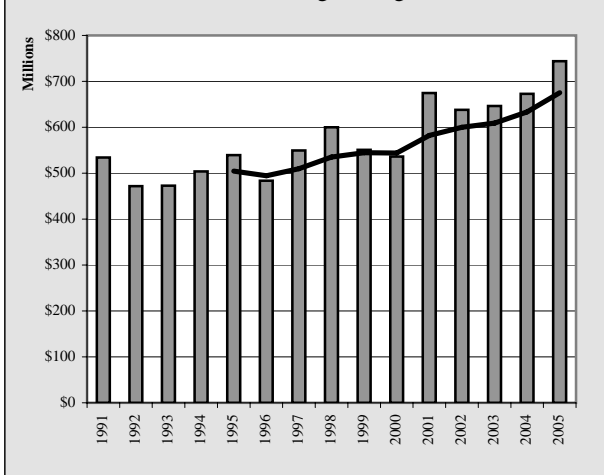

Chart 7.6

Other KPB Sales

Other KPB YTD 9/30 TAXABLE Sales by Industry - 1999-2005 - in \$							
	1999	2000	2001	2002	2003	2004	2005
AFF	1,420,813	1,518,196	1,661,859	1,747,846	1,854,326	2,066,547	2,228,305
Min	2,669,013	3,221,282	4,040,314	4,331,326	3,557,614	3,825,808	3,009,826
Const	4,184,311	4,305,419	4,598,196	4,931,074	5,054,210	5,008,751	4,960,712
Manu	2,432,260	2,562,772	2,496,667	2,480,542	2,115,998	2,368,992	2,514,688
TCPU	28,898,863	28,917,667	30,588,239	32,530,240	27,788,523	29,204,555	35,155,191
Whole	6,885,105	8,084,866	8,250,172	8,567,619	8,902,359	9,428,609	9,612,162
Retail	57,877,333	63,447,556	66,267,830	67,386,043	70,402,470	69,997,425	71,457,784
FIRE	4,385,245	4,376,950	4,854,788	5,075,016	5,537,201	5,227,916	5,496,211
Service	37,655,385	40,939,635	42,025,640	41,134,919	41,340,772	45,695,787	47,182,165
Govt	0	0	0	0	0	12,604	13,317
Total	146,408,328	157,374,343	164,783,705	168,184,625	166,553,473	172,836,994	181,630,361
Annual Change		7.5%	4.7%	2.1%	-1.0%	3.8%	5.1%

Table 7.10

Other KPB YTD 9/30 TAXABLE Sales Ten Year Change by INDUSTRY - 1995 v. 2005 - in \$				
	10 Year Change			
	1995	2005	Percentage	Numerical
AFF	1,296,294	2,228,305	71.9%	932,011
Min	3,141,001	3,009,826	-4.2%	-131,175
Const	3,603,256	4,960,712	37.7%	1,357,456
Manu	2,009,661	2,514,688	25.1%	505,027
TCPU	24,880,819	35,155,191	41.3%	10,274,372
Whole	7,457,223	9,612,162	28.9%	2,154,939
Retail	53,299,757	71,457,784	34.1%	18,158,027
FIRE	3,699,531	5,496,211	48.6%	1,796,680
Service	27,700,483	47,182,165	70.3%	19,481,682
Govt	0	13,317	0.0%	13,317
Total	127,088,025	181,630,361	42.9%	54,542,336

Table 7.11

Other KPB YTD 9/30 TAXABLE Sales One Year Change by INDUSTRY - 2004 v. 2005 - in \$				
	1 Year Change			
	2004	2005	Percentage	Numerical
AFF	2,066,547	2,228,305	7.8%	161,758
Min	3,825,808	3,009,826	0.0%	-815,982
Const	5,008,751	4,960,712	-1.0%	-48,039
Manu	2,368,992	2,514,688	6.2%	145,696
TCPU	29,204,555	35,155,191	20.4%	5,950,636
Whole	9,428,609	9,612,162	1.9%	183,553
Retail	69,997,425	71,457,784	2.1%	1,460,359
FIRE	5,227,916	5,496,211	5.1%	268,295
Service	45,695,787	47,182,165	3.3%	1,486,378
Govt	12,604	13,317	5.7%	713
Total	172,836,994	181,630,361	5.1%	8,793,367

Table 7.12

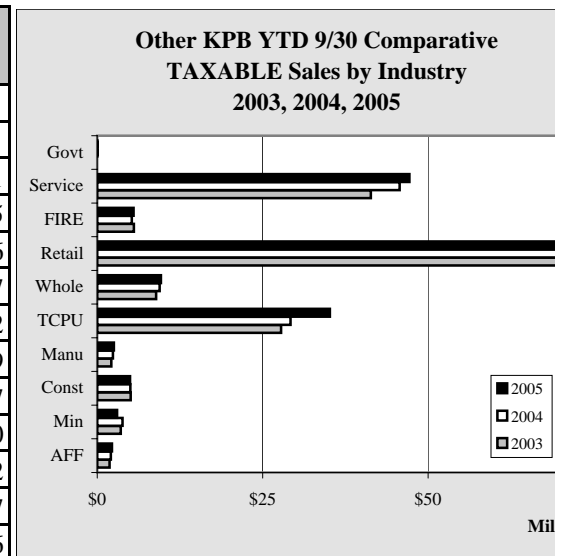

Chart 7.7

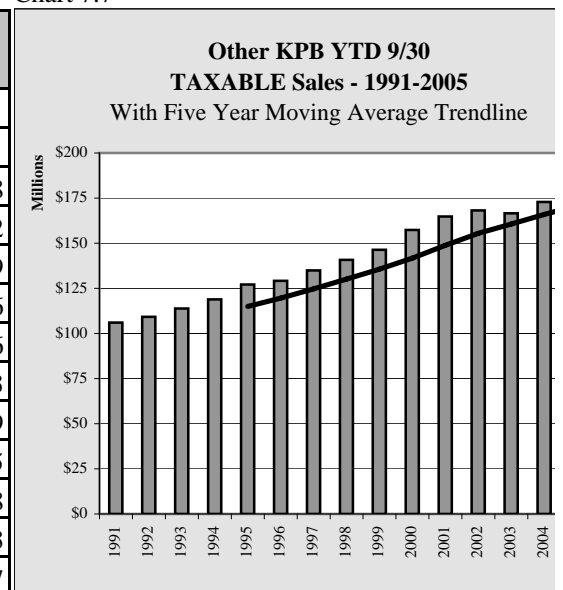
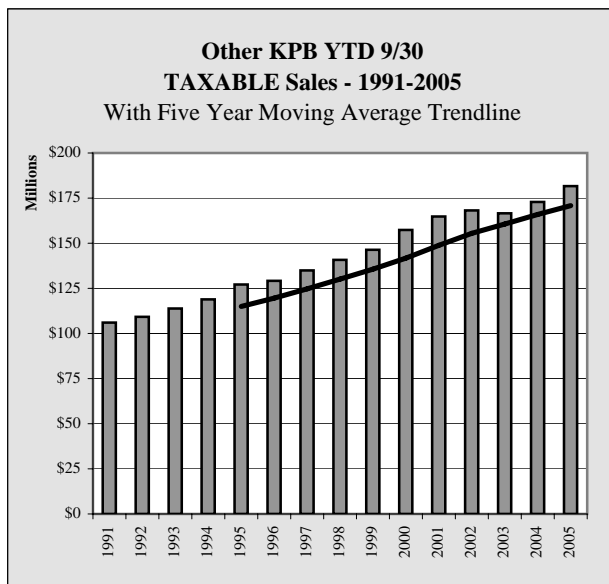
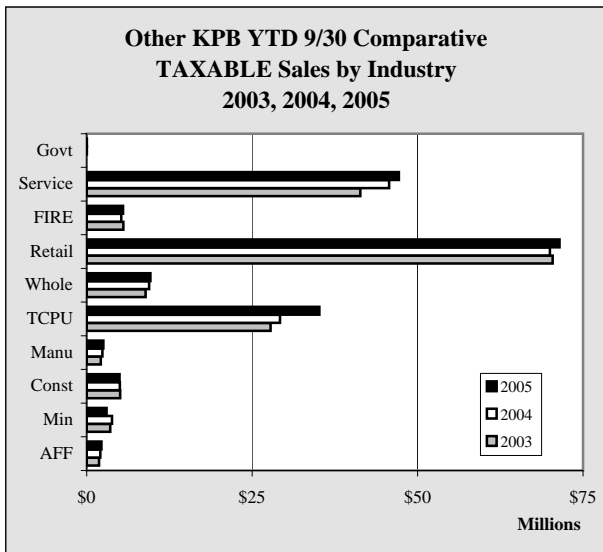

Chart 7.8

Other KPB Sales

Annual Change
7.8%
-21.3%
-1.0%
6.2%
20.4%
1.9%
2.1%
5.1%
3.3%
NA
5.1%



Other KPB Sales

Other KPB Annual GROSS Sales by Industry - 1998-2004 - in \$								
	1998	1999	2000	2001	2002	2003	2004	Annual Change
AFF	6,119,386	2,812,823	2,875,629	3,242,403	4,090,590	4,814,409	5,857,634	21.7%
Min	187,521,559	113,163,554	115,625,431	123,091,789	108,808,400	101,004,267	155,698,225	54.2%
Const	88,142,507	87,808,495	88,853,048	136,499,774	131,261,695	133,817,324	130,423,015	-2.5%
Manu	112,671,455	132,512,994	85,638,574	250,593,511	164,076,655	159,471,272	143,967,105	-9.7%
TCPU	73,567,609	78,647,818	66,837,538	77,388,092	73,138,015	63,786,231	78,102,991	22.4%
Whole	101,466,620	91,041,042	101,310,365	104,710,505	108,334,825	115,986,698	118,995,491	2.6%
Retail	128,963,750	128,644,968	138,967,225	153,029,767	155,130,975	166,739,518	167,767,455	0.6%
FIRE	15,909,441	15,194,140	13,106,195	15,680,221	14,436,076	16,516,352	19,489,941	18.0%
Service	78,651,481	83,322,595	95,090,680	100,412,737	102,659,177	99,412,413	114,835,748	15.5%
Govt	6,585	0	0	0	0	0	13,732	NA
Total	793,020,393	733,148,429	708,304,685	964,648,799	861,936,408	861,548,484	935,151,337	8.5%
Annual Change		-7.5%	-3.4%	36.2%	-10.6%	0.0%	8.5%	

Table 7.13

Other KPB Annual GROSS Sales Ten Year Change by INDUSTRY - 1994 v. 2004 - in \$				
	10 Year Change			
	1994	2004	Percentage	Numerical
AFF	7,039,064	5,857,634	-16.8%	-1,181,430
Min	116,944,474	155,698,225	33.1%	38,753,751
Const	90,806,962	130,423,015	43.6%	39,616,053
Manu	87,256,013	143,967,105	65.0%	56,711,092
TCPU	148,325,464	78,102,991	-47.3%	-70,222,473
Whole	36,237,591	118,995,491	228.4%	82,757,900
Retail	101,982,121	167,767,455	64.5%	65,785,334
FIRE	16,835,148	19,489,941	15.8%	2,654,793
Service	58,725,736	114,835,748	95.5%	56,110,012
Govt	309	13,732	0.0%	13,423
Total	664,152,882	935,151,337	40.8%	270,998,455

Table 7.14

Other KPB Annual GROSS Sales One Year Change by INDUSTRY - 2003 v. 2004 - in \$				
	1 Year Change			
	2003	2004	Percentage	Numerical
AFF	4,814,409	5,857,634	21.7%	1,043,225
Min	101,004,267	155,698,225	0.0%	54,693,958
Const	133,817,324	130,423,015	-2.5%	-3,394,309
Manu	159,471,272	143,967,105	-9.7%	-15,504,167
TCPU	63,786,231	78,102,991	22.4%	14,316,760
Whole	115,986,698	118,995,491	2.6%	3,008,793
Retail	166,739,518	167,767,455	0.6%	1,027,937
FIRE	16,516,352	19,489,941	18.0%	2,973,589
Service	99,412,413	114,835,748	15.5%	15,423,335
Govt	0	13,732	NA	13,732
Total	861,548,484	935,151,337	8.5%	73,602,853

Table 7.15

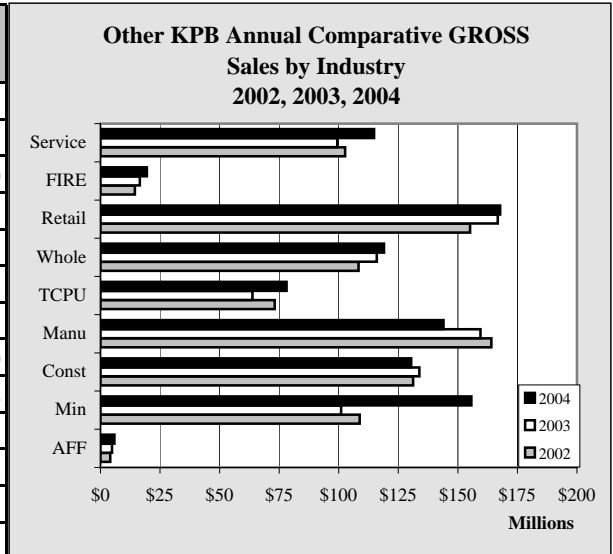

Chart 7.9



Chart 7.10

Other KPB Sales

Other KPB Annual TAXABLE Sales by Industry - 1998-2004 - in \$

	1998	1999	2000	2001	2002	2003	2004	Annual Change
AFF	1,722,929	1,738,057	1,945,844	2,016,782	2,152,460	2,281,300	2,540,907	11.4%
Min	5,144,815	3,724,685	4,434,095	5,598,954	5,598,990	4,655,675	5,218,907	12.1%
Const	5,738,513	5,621,785	5,735,340	6,115,447	6,566,858	6,597,575	6,756,897	2.4%
Manu	3,388,424	3,021,658	3,084,591	3,041,030	2,944,959	2,626,320	2,872,294	9.4%
TCPU	35,992,074	39,160,283	39,092,526	42,147,135	41,606,993	37,098,365	40,099,801	8.1%
Whole	8,733,322	9,868,388	11,100,421	11,675,046	11,425,901	12,058,985	12,951,451	7.4%
Retail	72,533,481	75,119,590	80,838,970	85,853,411	86,150,313	89,676,971	88,807,594	-1.0%
FIRE	5,494,477	5,585,421	5,678,461	6,363,047	6,509,160	7,049,609	6,795,945	-3.6%
Service	40,794,714	43,554,212	47,432,032	48,734,123	47,390,646	47,550,992	52,179,427	9.7%
Govt	6,585	0	0	0	0	0	13,667	NA
Total	179,549,334	187,394,079	199,342,280	211,544,975	210,346,280	209,595,792	218,236,890	4.1%
Annual Change		4.4%	6.4%	6.1%	-0.6%	-0.4%	4.1%	

Table 7.16

**Other KPB Annual TAXABLE Sales Ten Year Change
by INDUSTRY - 1994 v. 2004 - in \$**

	10 Year Change			
	1994	2004	Percentage	Numerical
AFF	1,589,960	2,540,907	59.8%	950,947
Min	6,087,175	5,218,907	-14.3%	-868,268
Const	4,492,057	6,756,897	50.4%	2,264,840
Manu	2,201,874	2,872,294	30.4%	670,420
TCPU	33,712,193	40,099,801	18.9%	6,387,608
Whole	8,669,153	12,951,451	49.4%	4,282,298
Retail	61,786,255	88,807,594	43.7%	27,021,339
FIRE	4,645,736	6,795,945	46.3%	2,150,209
Service	29,389,956	52,179,427	77.5%	22,789,471
Govt	309	13,667	0.0%	13,358
Total	152,574,668	218,236,890	43.0%	65,662,222

Table 7.17

**Other KPB Annual TAXABLE Sales One Year Change
by INDUSTRY - 2003 v. 2004 - in \$**

	1 Year Change			
	2003	2004	Percentage	Numerical
AFF	2,281,300	2,540,907	11.4%	259,607
Min	4,655,675	5,218,907	0.0%	563,232
Const	6,597,575	6,756,897	2.4%	159,322
Manu	2,626,320	2,872,294	9.4%	245,974
TCPU	37,098,365	40,099,801	8.1%	3,001,436
Whole	12,058,985	12,951,451	7.4%	892,466
Retail	89,676,971	88,807,594	-1.0%	-869,377
FIRE	7,049,609	6,795,945	-3.6%	-253,664
Service	47,550,992	52,179,427	9.7%	4,628,435
Govt	0	13,667	0.0%	13,667
Total	209,595,792	218,236,890	4.1%	8,641,098

Table 7.18

**Other KPB Annual Comparative TAXABLE
Sales by Industry
2002, 2003, 2004**

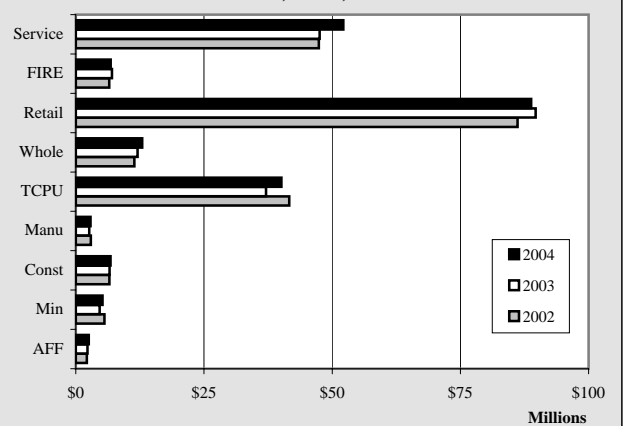

Chart 7.11

**Other KPB Annual TAXABLE Sales - 1991-
2004**

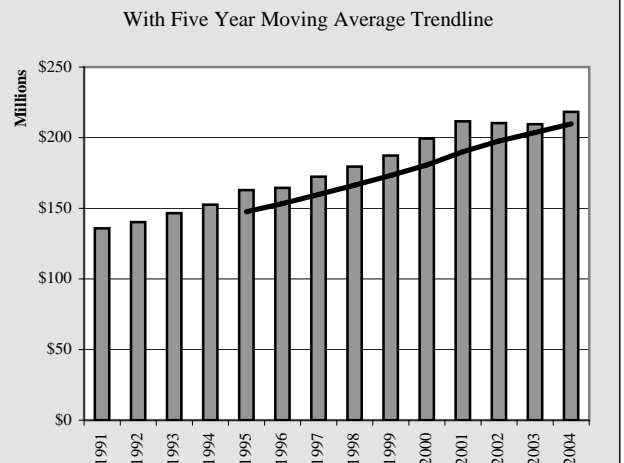

Chart 7.12

Other KPB Sales

Other KPB GROSS Sales by Industry by Quarter - 2002-2005 -				
	1st Quarter	2nd Quarter	3rd Quarter	4th Quarter
2002				
AFF	447,651	1,142,492	1,430,097	1,070,350
Min	32,299,252	29,103,164	25,287,979	22,118,005
Const	24,605,950	30,778,098	40,528,297	35,349,350
Manu	14,954,570	34,871,253	44,941,727	69,309,105
TCPU	18,420,972	18,167,731	21,630,289	14,919,023
Whole	21,943,141	28,469,316	31,837,444	26,084,924
Retail	28,752,133	40,486,870	50,013,715	35,878,257
FIRE	3,214,862	3,704,383	3,878,053	3,638,778
Serv	14,742,430	28,996,481	43,193,240	15,727,026
Govt	0	0	0	0
Total	159,380,961	215,719,788	262,740,841	224,094,818
2003				
AFF	445,085	2,042,231	1,578,920	748,173
Min	18,139,022	24,039,296	28,701,184	30,124,765
Const	21,972,208	35,928,211	44,783,625	31,133,280
Manu	31,662,293	22,050,431	53,343,537	52,415,011
TCPU	14,598,070	15,634,861	18,568,068	14,985,232
Whole	20,948,522	29,652,374	37,077,443	28,308,359
Retail	30,775,644	46,327,872	52,439,119	37,196,883
FIRE	2,853,597	4,594,592	5,140,046	3,928,117
Serv	12,971,156	27,700,199	42,294,496	16,446,562
Govt	0	0	0	0
Total	154,365,597	207,970,067	283,926,438	215,286,382
2004				
AFF	438,254	1,256,193	1,632,207	2,530,980
Min	37,672,228	29,692,204	36,588,670	51,745,123
Const	15,137,343	22,794,483	37,203,422	55,287,767
Manu	21,943,272	7,606,427	87,311,541	27,105,865
TCPU	14,959,439	16,722,028	20,217,590	26,203,934
Whole	22,031,868	28,462,396	36,327,578	32,173,649
Retail	30,009,584	45,707,167	54,327,215	37,723,489
FIRE	3,774,169	3,981,211	4,894,601	6,839,960
Serv	13,197,994	30,871,120	48,091,816	22,674,818
Govt	6,365	0	6,304	1,063
Total	159,170,516	187,093,229	326,600,944	262,286,648
2005				
AFF	478,964	1,540,365	1,174,400	
Min	37,465,302	34,249,462	42,053,583	
Const	21,908,277	29,431,210	36,475,346	
Manu	30,078,000	50,593,679	84,878,977	
TCPU	18,903,647	19,070,982	22,628,374	
Whole	25,155,668	18,499,445	23,067,251	
Retail	30,368,962	49,511,270	55,141,163	
FIRE	3,268,083	5,129,447	6,383,709	
Serv	15,268,470	33,019,796	48,288,262	
Govt	13,317	0	0	
Total	182,908,690	241,045,656	320,091,065	

Table 7.19

Other KPB Sales

in \$
Total
4,090,590
108,808,400
131,261,695
164,076,655
73,138,015
108,334,825
155,130,975
14,436,076
102,659,177
0
861,936,408
4,814,409
101,004,267
133,817,324
159,471,272
63,786,231
115,986,698
166,739,518
16,516,352
99,412,413
0
861,548,484
5,857,634
155,698,225
130,423,015
143,967,105
78,102,991
118,995,491
167,767,455
19,489,941
114,835,748
13,732
935,151,337
Year to Date
3,193,729
113,768,347
87,814,833
165,550,656
60,603,003
66,722,364
135,021,395
14,781,239
96,576,528
13,317
744,045,411

Other KPB Sales

Other KPB TAXABLE Sales by Industry by Quarter - 2002-2005				
	1st Quarter	2nd Quarter	3rd Quarter	4th Quarter
2002				
AFF	396,517	780,587	570,742	404,614
Min	1,424,074	1,417,403	1,489,849	1,267,664
Const	1,132,055	1,657,737	2,141,282	1,635,784
Manu	396,651	881,441	1,202,450	464,417
TCPU	12,140,823	11,314,077	9,075,340	9,076,753
Whole	2,865,394	2,743,971	2,958,254	2,858,282
Retail	16,309,155	23,266,764	27,810,124	18,764,270
FIRE	1,506,676	1,626,536	1,941,804	1,434,144
Serv	5,633,539	13,671,993	21,829,387	6,255,727
Govt	0	0	0	0
Total	41,804,884	57,360,509	69,019,232	42,161,655
2003				
AFF	360,151	859,055	635,120	426,974
Min	1,190,125	1,114,615	1,252,874	1,098,061
Const	1,142,314	1,889,309	2,022,587	1,543,365
Manu	355,143	792,161	968,694	510,322
TCPU	9,916,712	9,184,673	8,687,138	9,309,842
Whole	2,773,715	2,930,861	3,197,783	3,156,626
Retail	16,138,323	25,347,109	28,917,038	19,274,501
FIRE	1,454,902	1,841,558	2,240,741	1,512,408
Serv	5,055,788	14,212,739	22,072,245	6,210,220
Govt	0	0	0	0
Total	38,387,173	58,172,080	69,994,220	43,042,319
2004				
AFF	402,891	915,588	748,068	474,360
Min	977,166	1,018,997	1,829,645	1,393,099
Const	1,180,160	1,723,460	2,105,131	1,748,146
Manu	367,901	785,263	1,215,828	503,302
TCPU	10,258,635	8,908,793	10,037,127	10,895,246
Whole	3,328,186	2,862,301	3,238,122	3,522,842
Retail	16,063,851	24,642,219	29,291,355	18,810,169
FIRE	1,513,683	1,726,561	1,987,672	1,568,029
Serv	4,980,414	15,603,491	25,111,882	6,483,640
Govt	6,300	0	6,304	1,063
Total	39,079,187	58,186,673	75,571,134	45,399,896
2005				
AFF	427,578	957,059	843,668	
Min	1,011,467	976,689	1,021,670	
Const	1,143,225	1,890,124	1,927,363	
Manu	407,910	932,531	1,174,247	
TCPU	12,364,259	11,341,922	11,449,010	
Whole	3,214,145	2,911,677	3,486,340	
Retail	15,897,213	25,393,755	30,166,816	
FIRE	1,421,097	1,839,574	2,235,540	
Serv	5,191,545	16,547,902	25,442,718	
Govt	13,317	0	0	
Total	41,091,756	62,791,233	77,747,372	

Table 7.20

Other KPB Sales

- in \$
Total
2,152,460
5,598,990
6,566,858
2,944,959
41,606,993
11,425,901
86,150,313
6,509,160
47,390,646
0
210,346,280
2,281,300
4,655,675
6,597,575
2,626,320
37,098,365
12,058,985
89,676,971
7,049,609
47,550,992
0
209,595,792
2,540,907
5,218,907
6,756,897
2,872,294
40,099,801
12,951,451
88,807,594
6,795,945
52,179,427
13,667
218,236,890
Year to Date
2,228,305
3,009,826
4,960,712
2,514,688
35,155,191
9,612,162
71,457,784
5,496,211
47,182,165
13,317
181,630,361

KPB Local Officials Directory

Officials of the various governing bodies within the Kenai Peninsula Borough are listed on the following pages.

The officials listed are those who held office at the time of printing of the report. Annual elections for public officials are held each October. For information regarding current public officials, check the appropriate website.

Kenai Peninsula Borough - <http://www.borough.kenai.ak.us/>

Kenai Peninsula Borough School District - <http://www.kpbsd.k12.ak.us/>

City of Homer – <http://www.ci.homer.ak.us/>

City of Kenai – <http://www.ci.kenai.ak.us/>

City of Seldovia – <http://www.xyz.net/~seldovia/>

City of Seward – <http://www.cityofseward.net/>

City of Soldotna - <http://www.ci.soldotna.ak.us/>

KPB Local Officials Directory

Kenai Peninsula Borough Mayors

Kenai Peninsula Borough

Mayor John J. Williams
144 North Binkley
Soldotna, AK 99669
907-262-4441

City of Homer

Mayor James C. Hornaday
491 East Pioneer Ave.
Homer, AK 99603
907-235-8121

City of Kachemak

Mayor Philemon Morris
PO Box 598
Homer, AK 99603
907-235-8897

City of Kenai

Mayor Pat Porter
210 Fidalgo Street, Suite 200
Kenai, AK 99611
907-283-7535

City of Seldovia

Mayor Dick Wyland
Drawer B
Seldovia, AK 99663
907-234-7643

City of Seward

Mayor Vanta Shafer
PO Box 167
Seward, AK 99664
907-224-4046

City of Soldotna

Mayor Dave Carey
177 North Birch
Soldotna, AK 99669
907-262-9107

Table 8.1

KPB Local Officials Directory

<i>Kenai Peninsula Borough Mayor & Assembly</i>				
144 N. Binkley Soldotna, Alaska 99669 Phone 907-714-2160 Assembly/Clerk Fax: 907-714-2388 Assembly e-mail: assemblyclerk@borough.kenai.ak.us				
<i>Office / District</i>	<i>Name / Address</i>	<i>Phone / Fax / E-Mail</i>	<i>Term Expires</i>	<i>Previously Elected</i>
Borough Mayor	John Williams 144 N. Binkley St. Soldotna, AK 99669	714-2150 W 283-4960 H 262-8616 F jwilliams@borough.kenai.ak.us	2008	2005
Assembly 1 Kalifornsky	Dan Chay 37306 Cetacea Lane Kenai, AK 99611	283-9227 H 283-7588 F chay@alaska.com	2006	2003
Assembly 2 Kenai	Margaret Gilman 216 Susieana Lane Kenai, AK 99611	283-0860 H mbgilman@gci.net	2008	2005
Assembly 3 Nikiski	Gary Superman P.O. Box 8425 Nikiski, AK 99635	776-8448 H 776-8098 F 252-5264 W gsuperman@gci.net	2007	2001, 2004
Assembly 4 Soldotna	Pete Sprague - Vice President 188 Farnsworth Blvd. Soldotna, AK 99669	262-4073 H 262-8615 F psprague@acsalaska.net	2007	1998, 2001, 2002, 2004
Assembly 5 - Sterling / Funny River	Grace Merkes P.O. Box 8 Sterling, AK 99672	262-9811 H merkes2@yahoo.com	2008	1991, 1992, 1993, 1996, 1999, 2002, 2005
Assembly 6 East Peninsula	Ron Long - President P.O. Box 2464 Seward, AK 99664	224-7068 H 224-5707 F rlms@ptialaska.net	2006	2000, 2003
Assembly 7 Central	Paul Fischer P.O. Box 889 Kasilof, AK 99610	262-9269 H 262-4902 F akjfischer@hotmail.com	2007	1998, 2001, 2002, 2004
Assembly 8 Homer	Deb Germano P.O. Box 1511 Homer, AK 99603	235-2538 H debgermano@acsalaska.net	2008	2005
Assembly 9 South Peninsula	Milli Martin P.O. Box 2652 Homer, AK 99603	235-6652 H 235-6652 F millimom@xyz.net	2006	2000, 2002, 2003
Borough Clerk	Sherry Biggs 144 N. Binkley St. Soldotna, AK 99669	714-2160 262-8615 Fax assemblyclerk@borough.kenai.ak.us		

Table 8.2

KPB Local Officials Directory

KENAI PENINSULA BOROUGH		
PLANNING COMMISSION MEMBERS		
2005		
Member	Contact Information	Term Expires
CHAIRMAN		
Philip Bryson P.O. Box 1041 Kenai, Alaska 99611-1041	283-4672 work 283-4428 home	Kenai City Term Expires July 31, 2007
VICE CHAIRMAN		
Tom Clark P.O. Box 962 Anchor Point, Alaska 99556-0962	235-2887 home	Anchor Point/Ninilchik Term Expires July 31, 2007
Bonnie Heimbuch 987 Keystone Drive Soldotna, Alaska 99669	262-6887 - home	Soldotna City Term Expires July 31, 2008
Dr. Rick Foster P.O. Box 3328 Homer, AK 99603-3328	235-9100 - home	Homer City Term Expires July 31, 2007
Mari Anne Gross 57485 Clover Avenue Homer, Alaska 99603	235-7330 - home	Southwest Borough Term Expires July 31, 2008
Lynn Hohl P.O. Box 333 Seward, Alaska 99664-0333	224-7300 - home	Seward City Term Expires July 31, 2008
William Hutchinson P.O. Box 2585 Soldotna, Alaska 99669-2585	262-5256 - home	Ridgeway Term Expires July 31, 2007
James Isham P.O. Box 51 Soldotna, Alaska 99669-0051	262-9200 - home	Sterling Term Expires July 31, 2006
Brent Johnson 20773 Porcupine Lane Clam Gulch, Alaska 99568-9713	262-4763 - home	Kasilof/Clam Gulch Term Expires July 31, 2006
Blair Martin P.O. Box 1776 Soldotna, Alaska 99669-1776	283-5227 - home	Kalifornsky Beach Term Expires July 31, 2006
Mark Massion P.O. Box 203 Seldovia, Alaska 99663-0278	234-7575 - home	Seldovia City Term Expires July 31, 2006
Todd Petersen P.O. Box 651 Seward, Alaska 99664-0651	288-5050 - home 224-3350 - work 224-2388 - work fax	East Peninsula Term Expires July 31, 2007
Ray Tauriainen P.O. Box 8678 Nikiski, Alaska 99635-8678	776-8885 - home	Northwest Borough Term Expires July 31, 2008

Email address for the Planning Commission: planning@borough.kenai.ak.us

Fax Number for the Planning Commission: 907-262-8618

Table 8.3

KPB Local Officials Directory

Kenai Peninsula Borough School District			
148 North Binkley Street Soldotna, AK 99669 907-262-5846			
<u>Board of Education</u>			
Debra Mullins, President	53630 Redoubt Drive Kenai, AK 99611	907-776-6360	Term Expires 2008
Sammie Crawford, Vice President	36615 Chinulna Drive Kenai, AK 99611	904-283-9271	Term Expires 2007
Sandra Wassilie, Clerk	P.O. Box 1576 Seward, AK 99664	907-224-3950	Term Expires 2007
Bill Hatch	P.O. Box 2305 Kenai, AK 99611	907-283-5122	Term Expires 2006
Marty Anderson	P.O. Box 1388 Sterling, AK 99672	907-260-7500	Term Expires 2006
Nels Anderson, MD	303 Diane Lane Soldotna, AK 99669	907-262-3280	Term Expires 2008
Debbie Brown	P.O. Box 592 Kasilof, AK 99610	907-262-4551	Term Expires 2008
Elizabeth Downing	1247 Bay Avenue Homer, AK 99603	907-235-8555	Term Expires 2006
Sunni Hilts	P.O. Box 144 Seldovia, AK 99663	907-234-7692	Term Expires 2007
Student Representative Kelly King	Soldotna High School 425 W. Marydale Ave. Soldotna, AK 99669		Term Expires 9/2006

Table 8.4

<u>Administration</u>
Dr. Donna Peterson, Superintendent of Schools Sam Stewart, Assistant Superintendent Gary Whiteley, Assistant Superintendent of Instruction Melody Douglas, Chief Financial Officer Tim Peterson, Director of Human Resources

Table 8.5

KPB Local Officials Directory

Kenai Peninsula Borough Department Directors	
Switchboard	262-4441
Assessing	Shane Horan
Capital Projects	Rob Robson
Clerk	Sherry Biggs
Finance	Craig Chapman
Legal	Colette Thompson
Maintenance	Dave Tressler
Resource Planning	Max Best
Road Maintenance	Gary Davis
Solid Waste	Cathy Mayer

Table 8.6

Kenai Peninsula Borough Economic Development Agencies
<p>KP Economic Development District - EDD 14790 Kenai Spur Highway, Ste. 106A Kenai, AK 99611 907-283-3335</p>
<p>Kenai Peninsula Tourism Marketing Council 14790 Kenai Spur Highway, Ste. 103A Kenai, AK 99611 907-283-3850</p>
<p>KP Resource Conservation and Development, Inc. Trading Bay Plaza, Suite 150 PO Box 800, Kenai, AK 99611 907-283-7493</p>

Table 8.7